

# Selecting and Sizing Ball Screw Drives

Jeff G. Johnson, Product Engineer, Thomson Industries, Inc.

## Introduction

The ball screw drive is an assembly that converts rotary motion to linear motion and vice versa. The ball screw drive consists of a ball screw and a ball nut with recirculating ball bearings (Fig. 1). The connection between the screw and the nut is made by ball bearings that roll in the matching forms in the screw and ball nut. The forces transmitted are distributed over a large number of ball bearings, giving a comparatively low relative load per ball. With rolling elements the ball screw drive has a very low friction coefficient. Ball screw drives typically provide mechanical efficiency of greater than 90%, so their higher initial cost is often offset by reduced power requirements. The features of ball screws in relation to other linear actuation devices are summarized in Figure 2 and the important ball screw specifications are summarized in Figure 3.

## Optional Inputs

Figure 4 provides an overview of the parameters used in the ball screw selection and sizing process. The optional inputs make it possible for the designer to specify basic preferences for a specific type of ball screw early in the selection process. It's important to note that specifying optional inputs may unnecessarily restrict component selection. As an example, if you select metric product series you eliminate about half of the possible ball screw alternatives even though it's possible that an inch series ball screw might work just as well in the application.

## System Basic Parameters

The system basic parameters identify the basic geometric requirements of the application. The system orientation is important because with a horizontal orientation the load is equal to the payload weight times the frictional coefficient

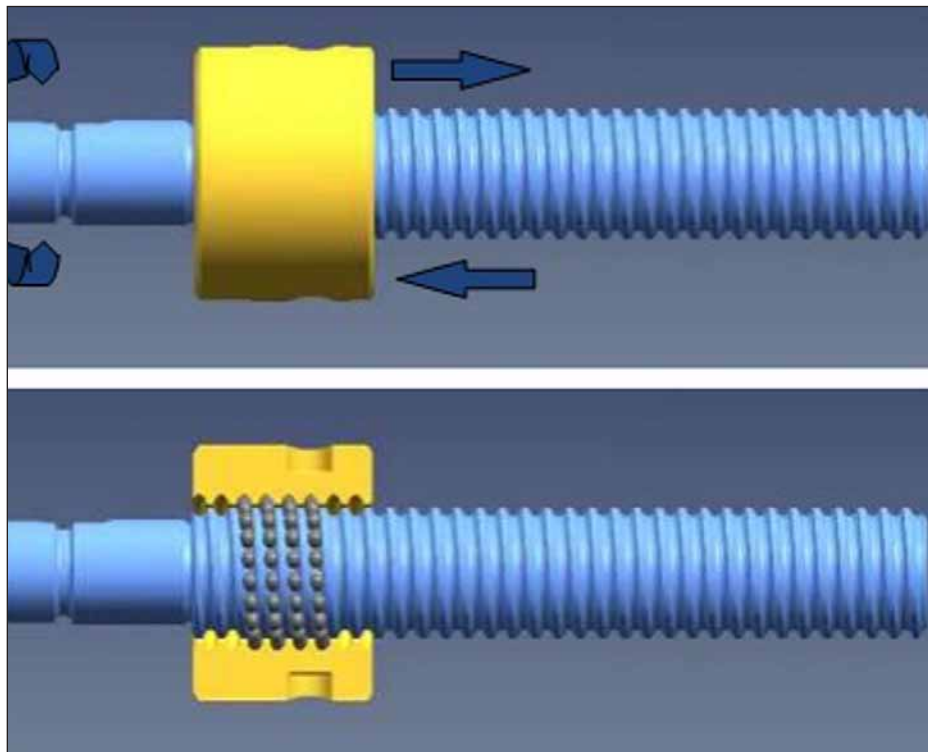

Figure 1 Ball screw drive is a popular linear actuator.

while with a vertical orientation the load is equal to the weight. The positional requirements determine which grade of ball screw is suitable for the application. Figure 5 shows the positional accuracy capabilities of various types of ball screws:

Backlash is the linear independent motion between the ball screw and the ball nut and can be controlled by preloading the nut. With skip-lead preload, the lead is offset within the ball nut to provide a precise preload. This type of preload is typically used where both repeatability and high stiffness are needed. Double-nut adjustable preload involves the use of a compression spring to axially load two ball nuts against each other. It is typically used for positioning applications where repeatability is critical. Where no preload is used, axial play is present between the screw and nut, typically 0.002 inch to 0.008

inch depending on the size. No preload is typically used for transport or vertical applications.

The type of drive system is another basic screw parameter. In a screw-driven system, the nut is fixed and the screw is driven while in a nut-driven system the screw is fixed and the nut is driven. Mounting of ball screw ends is described as either supported or fixed. A supported end holds the ball screw at one focal point and does not resist bending moments. A fixed end resists bending moment loads because it is typically based on two bearings spaced sufficiently so the ball screw remains perpendicular to the planes of the rotary bearings. The fixed offers great column strength and higher critical speed. On the other hand, a supported end is more compact and has a lower cost. A supported end is generally easier to align and install than a fixed end so

installation costs are typically lower. A ball screw can be fixed at one end and free at the other; supported at both ends; fixed at one end and supported at the other; fixed at both ends.

### Application Parameters

Application parameters begin with defining the direction and magnitude of the load. The ball screw works best with axial load only. The ability of a ball screw to avoid buckling under a compressive load is called its column strength. The screw must carry an axial load that is equal and opposite to the load generated on the ball nut by the motor's torque. In general, column strength is the controlling design parameter because for long columns it is much lower than the material's strength in compression. Because the length to diameter ratio is important in column buckling, it follows that the compression load strength of a ball screw is dependent upon its length. A ball screw with both ends fixed can be one and a half times longer than a ball screw with both ends merely supported and two and half times as long as a ball screw with a free end while supporting the same amount of load without buckling.

The limiting speed of a ball screw is usually its tendency to vibrate based on its natural frequency. The critical speed is the rotary speed that sets up harmonic vibrations in the ball screw and is a direct consequence of the characteristic frequency of vibration of the ball screw. For example, a 100 inch long 1 inch root diameter ball screw with both ends fixed has a natural frequency of about 18 Hz. With both ends supported rather than fixed the natural frequency of the same ball screw is reduced to about 8 Hz. If the rotational frequency of the screw matches the screw's natural frequency, slight imbalances in the screw can resonate. Excessive bending and bowing then keep the screw from working properly.

Some of the types of guides than can be used include linear rail and profile rail. The life should be defined based on the operational profile—how many hours per day, days per week and weeks per year the ball screw will be run—and the overall life requirement for the ball screw. For more complex applications,

Hand Actuation	Low cost, slow speed
Acme Screw	Low cost, moderate speeds, multiple positioning
Air cylinder	Single position, moderate loads, can be costly if you don't already have air, can drift
Ball Screw -- Precision Plus or Precision	High speeds, repeatable, accurate, moderate cost, longer strokes with rotating nut
Belt Drive	High speed, multiple positioning repeatable, moderate accuracy and load
Cable & Chain	Low cost, light duty applications, not very robust
Hydraulic Cylinder	Very high loads, single position
Linear Motor	Highest speeds, relatively lights loads, highest accuracy
Rack & Pinion	Moderate speed, long strokes, and moderate to heavy loads
Roller Screw	High loads, moderate speed

Figure 2 Summary of linear actuation devices.

you also have the option to build a complete motion profile. Each segment of the motion profile requires entry of the speed at the beginning of the segment, the speed at the end of the segment, the segment time and the torque during the segment.

### Selection and Sizing Example

To demonstrate how to select and size ball screws, we'll use a three-axis welding gantry application as an example (Fig 6). The ball screw runs the entire length of the x axis and is supported on either end by bearing supports. For simplicity's sake we will define the nut mounting as flange, material as alloy steel, thread direction as right hand and product series as Metric. The system orientation in this application is horizontal with a screw driven design. The length of the x axis is 6 meters. We will use fixed ends with a thermally stable flange mount. High levels of accuracy are not critical in this application, so we will select a precision ball screw with no preload. Wipers are needed because this is a dirty environment, but alloy steel is acceptable and no special finish is needed.

A load of 2,668.9 Newtons (600 lbs) is applied by a carriage riding on profile rails. The travel length is 4.5 m (177.165 in) and the unsupported length is 5.818

Important Ball Screw Specifications
<b>Static Load Rating</b> – Maximum non-operating load capacity above which brinelling of the ball track occurs. NEVER exceed the Static Load Rating
<b>Dynamic Load Rating</b> – Maximum load that an assembly can maintain for 1.0 million inches of travel (Inch Series) or 1.0 million revolutions (Metric Series). Exceeding the Dynamic Load Rating is not recommended
<b>Lead Error</b> – Amount of positional error per foot (Inch Series) or per 300mm (Metric Series). Measure of accuracy.
<b>Backlash</b> – Axial free motion between ball nut and ball screw. Measure of stiffness and repeatability.
<b>End Fixity</b> – End support configuration that affects speed and column loading

Figure 3 Ball screw specifications.

m (229.055 in). The required speed is 0.1 meters per second (3.927 in/sec) and an acceleration and deceleration of 2.5 m/s<sup>2</sup> (98.4 in/s<sup>2</sup>) is needed. The duty cycle is 8 hours per day, 5 days per week and 50 weeks per year with an average of 10 cycles per hour. The life requirement is 20 years for the ball screw and 5 years for components. An additional requirement is that a stepper motor be used due to a preference of the electrical engineering department.

Next, we will select the linear bearings for the x axis. The primary requirements of this application are high load capacity and high stiffness. The application involves a relatively long length of 5.5 meters (18 feet); however the

availability of 6 meter length screws eliminates the need for butt joining. Low maintenance is another important requirement of this application. The result was the selection of Thomson 500 Series ball profile rail linear guides.

With this selection made, we can calculate the load on the ball screws.

$$F = N \times \mu_r$$

Where:

$\mu_r$  is the frictional coefficient, which is 0.005 for this particular linear guide

$$F = 2,698 \text{ N} \times 0.005 = 13.3 \text{ N} (3.0 \text{ lbs})$$

$$F = ma = 2,668.9 \text{ N} / 9.81 \text{ m/s}^2 \times 2.5 \text{ m/s}^2 = 680.1 \text{ N} (153 \text{ lbs})$$

$$F_{eq} = -303.8 \text{ N} (68.3 \text{ lbs})$$

Based on this loading, we will select the NEFF KGF-D ball nut as the starting point. This ball nut has an integral flange, integral wiper and a DIN 69051 mounting and the ball screw has an accuracy of  $\pm 50 \mu\text{m} / 300 \text{ mm}$  accuracy.

Next we will look at the motor requirement. Because of our requirement to use a stepper drive we want to keep the rpm fairly low. The rpm can be determined by this formula:

$$\text{RPM} = \text{Travel rate (mm/min)} / \text{Lead (mm)}$$

Our options are:

- 100 mm/s \*60 / 1,200 rpm = 5 mm
- 100 mm/s \*60 / 600 rpm = 10 mm
- 100 mm/s \*60 / 300 rpm = 20 mm

Since we want to keep the RPM down, we will select a 20mm lead ball nut which meets our cycle time requirement while keeping the RPM down to levels that can be met by a stepper motor.

We can calculate the torque requirement using this formula:

$$T_d [N \bullet M] = 1.77 \times 10^{-4} \times F_{eq} \times P$$

Where:

- T = Torque (Nm)
- F = Load (N)
- P = Lead (mm)

The resulting torque is...

$$T_d = 2.15 \text{ Nm} (304.5 \text{ oz-in})$$

The maximum torque during acceleration is:

$$T_d = 4.82 \text{ Nm} (682.6 \text{ oz-in})$$

A NEMA 42 stepper motor was selected based on the application and torque data.

Next we will look at the critical screw speed which can be found using the following equation:

$$n_c (\text{rpm}) = C_s \times 1.2 \times 10^8 \times d_r / I^2$$

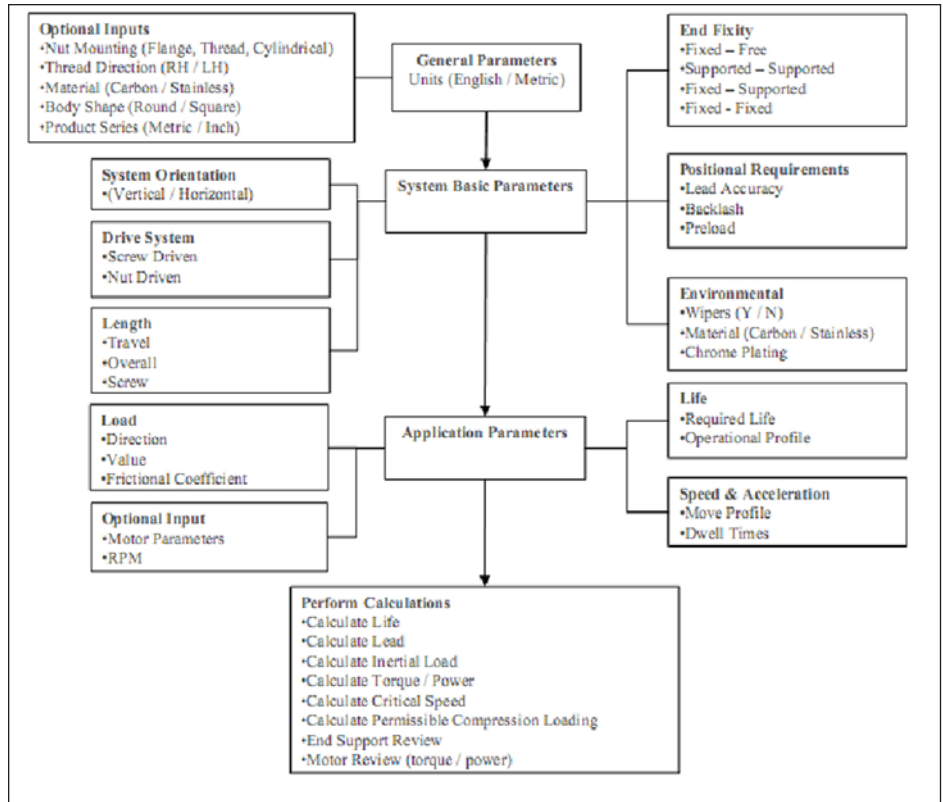

Figure 4 Ball screw selection and sizing parameters.

Ball screw type	Accuracy
Precision inch	$\pm 0.004 \text{ in/ft}$
Precision plus inch	$\pm 0.0005 \text{ in/ft}$
Precision metric - T7 Accuracy Class	$\pm 50 \mu\text{m}/300\text{m}$
Precision metric - P5 Accuracy Class	$\pm 23 \mu\text{m}/300\text{m}$
Precision plus metric - P3 Accuracy Class	$\pm 12 \mu\text{m}/300\text{m}$

Figure 5 Positional accuracy capabilities of various types of ball screws.

Where:

$C_s$  is a constant based on the end fixity factor:

$d_r$  = root diameter (mm)

I = unsupported length (mm)

$$63 \text{ mm} \times 20 \text{ mm}$$

$$d_r = 56.9 \text{ mm}$$

$$I = 5,818 \text{ mm}$$

$$n_c = 449.8 \text{ rpm}$$

$$n_s = n_c \times S (\text{safety factor of } 0.8)$$

$$n_s = 359.9 \text{ rpm}$$

$$300 < 359.9 - \text{Pass!}$$

In this case we shall consider three different ball screw sizes for critical speed in this application:

$$40 \text{ mm} \times 20 \text{ mm}$$

$$d_r = 35.9 \text{ mm}$$

$$I = 5,818 \text{ mm}$$

$$n_c = 283.8 \text{ rpm}$$

$$n_s = n_c \times S (\text{safety factor of } 0.8)$$

$$n_s = 227.1 \text{ rpm}$$

$$300 > 227.1 - \text{Fail!}$$

$$50 \text{ mm} \times 20 \text{ mm}$$

$$d_r = 44.1 \text{ mm}$$

$$I = 5,818 \text{ mm}$$

$$n_c = 348.6 \text{ rpm}$$

$$n_s = n_c \times S (\text{safety factor of } 0.8)$$

$$n_s = 278.9 \text{ rpm}$$

$$300 > 278.9 - \text{Fail!}$$

Now we will check critical nut speed which can be determined by the following formula:

$$DN = d_o \times n$$

Where:

$$DN = 140,000$$

$$d_o = \text{nominal diameter (mm)}$$

$$n = \text{rpm}$$

Evaluating the critical nut speed of the ball screw that meets our critical ball speed requirement:

$$DN = 63 \times 300 = 18,900$$

$$18,900 < 140,000 - \text{Pass!}$$

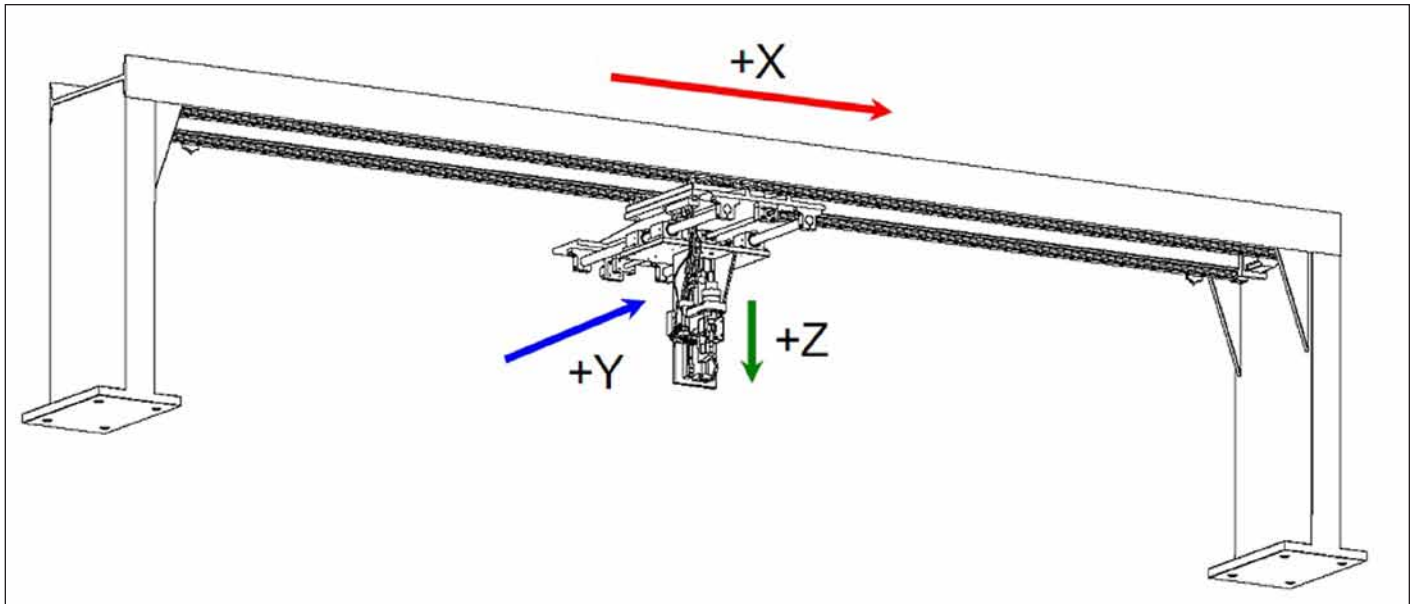

Figure 6 Welding gantry application.

Next we will look at compression loading in this application, which is determined by the following formula.

$$F_c [N] = C_s \times 9,687 \times 10^4 \times d_r^4 / l^2$$

Where:

$F_c$  = Critical buckling force (N)

$C_s$  = End fixity factor based on following table:

$d_r$  = root diameter (mm)

$l$  = unsupported length (mm)

Inputs:

$$D_r = 56.9$$

$$l = 5,818 \text{ mm}$$

$$C_s = 4.00$$

Outputs

$$F_c = 119,991.6 \text{ N}$$

$$F_s = F_c \times S \text{ (Safety factor of 0.8)}$$

$$F_s = 95,993 \text{ N}$$

Verification

$$680.1 \text{ N} < 95,993.3 \text{ N} - \text{Pass!}$$

The last thing to check is the life expectancy requirement. Life is typically rated at  $L_{10}$ , which represents the time after which 90 percent of ball screws will still perform.

$$L_{10} \text{ (revolutions)} = (C_{am} / F_{eq})^3 \times 10^6$$

In this application life expectancy is 1,035,752.6 years. The reason life is so high is that we selected the ball screw based on critical speed rather than life.

Finally we will check the life expectancy of the bearing supports. A typical fixed bearing support is the WBK Series. The life expectancy of a bearing support can be determined using this formula.

$$L_{10} \text{ (hours)} = (C_{am} / P_r)^3 \times (1 \times 10^6 / 60 \times n)$$

$$P_r = (0.35 \times F_r) + (0.57 \times F_a)$$

$$C_{am} = 51.5 \text{ kN (11,577.7 lbs)}$$

$$F_a = 68.3 \text{ lbs} / 2 = 34.15 \text{ lbs}$$

$$F_r = 0.0 \text{ lbs}$$

$$P_r = 19.47 \text{ lbs}$$

$$L_{10} = 22.1 \text{ years}$$

$$22.1 > 5 - \text{Pass!}$$

The ball screws driving the y and z axes can be selected and sized using similar methods.

## Conclusion

As this example shows, the selection of the correct ball screw assembly for a specific application is an iterative process that determines the smallest envelope and most cost-effective solution. The design load, linear velocity and positional accuracy are used to calculate the diameter, lead and load capacity of the ball screw assembly. Individual ball screw components are then selected based on life, dimensional constraints, mounting configuration and environmental conditions. **PTE**

### For more information:

Thomson Industries, Inc.

Wood Dale, IL

Phone: (540) 633-3549

Thomson@thomsonlinear.com

www.thomsonlinear.com

**Jeff Johnson**, product engineer for Industrial Screws, has been with Thomson for nearly six years. He is responsible for new product development and application support for the N.A. market, and specializes in ball screws



and lead screws. He has been involved with system and component design of linear motion products for over 20 years and holds numerous patents and technical citations. Johnson earned a Bachelor of Science in Aerospace Engineering and studied Mechanical Engineering at the University of Arizona. Johnson also earned his MBA by graduating Beta Sigma Gamma from the WP Carey School of Business at the Arizona State University with an emphasis in international marketing. He also is a registered professional engineer in mechanical engineering in California.