

# Analyzing Wind Power

## Equipment and Application Overview

*Power Transmission Engineering* is collaborating with the Bearing Specialists Association (BSA) on a special section within the magazine. *Bearing Briefs* will present updated reports on bearing topics for each issue in 2016. Complimentary access to all BSA Bearing and Industry Briefs is available on the BSA website at [www.bsahome.org/tools](http://www.bsahome.org/tools).



*We build relationships*

### Wind is a form of solar energy.

Winds are caused by the uneven heating of the atmosphere by the sun, the irregularities of the earth's surface, and rotation of the earth. Wind Turbines convert the kinetic energy in wind into mechanical power.

When the turbine blades turn, they rotate a low-speed shaft that is connected to a gear. This gear turns a smaller speed shaft that has a tighter rotation with greater torque, essentially concentrating the energy so it can move the rotor at much higher speeds than the wind moves the blades.

This process works by moving magnetic fields created by copper wire wound around a metal core, a common electromagnetic device. As the coils are turned and the magnetic fields shift, they create a charge that is then channeled in cables, creating a flow of electricity.

### Wind Power Main Shaft

#### Application Overview

After the wind load is transferred through the rotor, the main shaft bearing transmits the rotational torque to the gearbox.

#### Bearing Applications

Self-aligning spherical roller bearings are mainly utilized for the main shaft bearings because of their superior aligning characteristics and load durability.

#### Items to Consider

When selecting bearings for the main shaft one must consider rotor rotational speeds, appropriate loads, the shaft, housing rigidity, and lubrication.

### Wind Power Gearbox

#### Application Overview

The gearbox is the component that increases the rotational speed transmitted via the main shaft up to the point where power can be generated. It consists of planet gears, a ring gear, a low speed shaft, an intermediate shaft, and a high speed shaft.

#### Bearing Applications

A combination of cylindrical and tapered roller bearings are used to support the loads generated by the gears. Special clearances are often used. Full complement bearings and bearings on

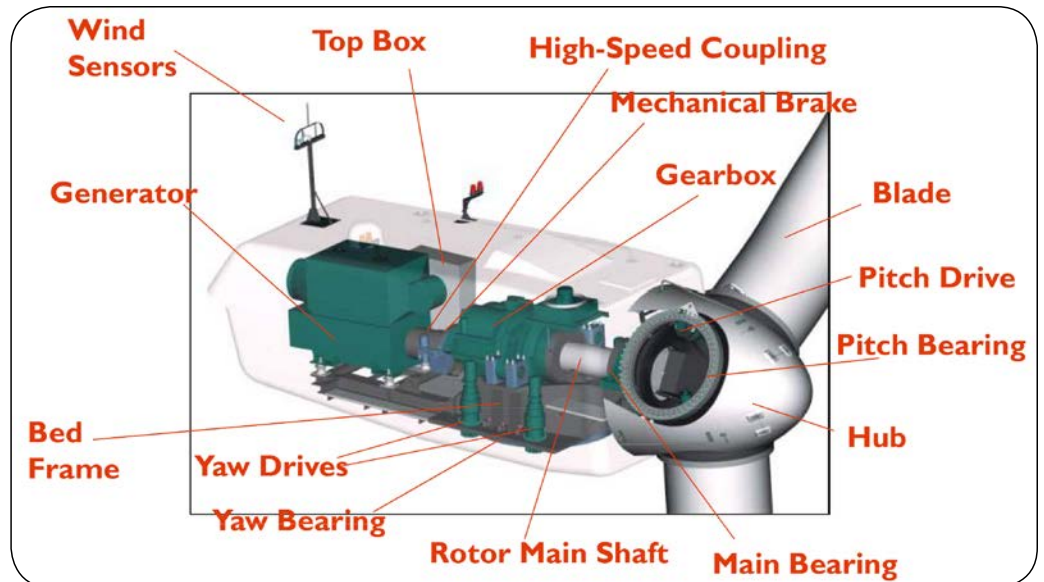

high speed shafts are often coated in a friction reducing coating (black oxide) to prevent damage caused by skidding.

#### Items to Consider

It is also important to investigate the proper bearings for the gearbox using an analysis program similar to that for the main shaft. If the rigidity of the planet gear is low, the ring gear deforms, and this may have an influence

on the inner components and shorten the service life of bearings. Service life of gearboxes is a major concern of the wind industry.

### Wind Power Generator

#### Application Overview

Generators convert the mechanical energy obtained from the wind into electrical energy.

#### Bearing Applications

Radial ball bearings are the most commonly used bearing due to the low friction and capacity requirements of this application.

#### Items to Consider

Bearings used in generators are subject to electric pitting—a phenomenon where the surface melts locally because sparks are generated as the electricity passes through the ultra-thin oil layer and into the bearing while rotating. This is one of the main factors that can lead to damage and reduce bearing service life. To combat this ceramic balls are used providing excellent insulation performance, reduced operating temperatures when rotating, leading to

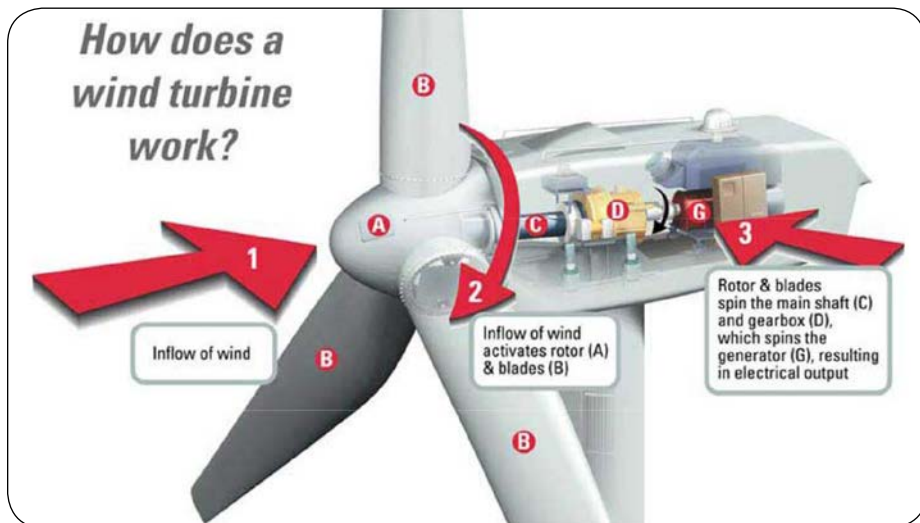

improved life of lubrication and duration of preventative maintenance.

### Pitch and Yaw

#### Application Overview

The Yaw Drive allows the turbine nacelle to rotate into the wind as the wind direction changes, as well as supports the nacelle on the tower. The Pitch Drive is used to feather the blade into and out of the wind to optimize blade

angle leading to improved performance.

#### Bearing Applications

These applications require long periods in nearly stationary positions with large static and vibratory loads. Typically 4 point or 8 point contact ball bearings are used due to their capability to carry radial, thrust, and moment loads.

# DieQua offers more gearboxes

## Are You Selecting The Right Technology?

Whether your application is for precise motion control or for general power transmission, there are several gear technologies that can do the job. But which one does it best?

Only DieQua offers the widest range of gearmotors, speed reducers and servo gearheads along with the experience and expertise to help you select the optimal solution to satisfy your needs.

If you are using gearboxes, you should be talking to DieQua!

**DIEQUA**  
Corporation  
www.diequa.com 630-980-1133

#### Power Transmission Solutions

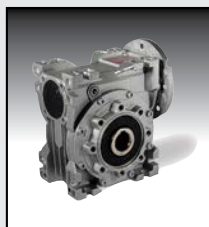

Worm Reducers

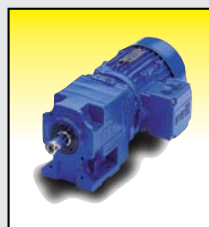

Helical Gearmotors

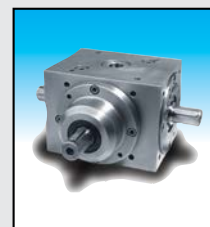

Spiral Bevel Gearboxes

#### Motion Control Solutions

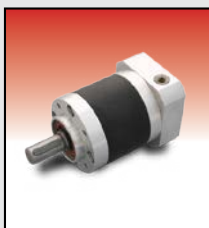

Planetary Gearheads

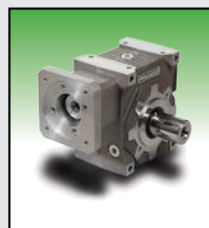

Servo Worm Gearheads



Precision Cycloidals

**Items to Consider**

For slewing bearing applications it is important to keep both bearing static capacity and stiffness in mind. One must also pay attention to the slewing rim gearing for optimum performance.

**Operations and Maintenance**

Turbines are designed for a 20 year life span—one of the biggest concerns facing Wind Farms today is how they should plan to operate after the OEM warranty period (typically 5 years).

79 percent of wind turbines were still under warranty in 2011, but that is going to be changing rapidly due to the large amount of installations in the past few years.

O&M costs for wind power are double or triple the figures originally projected. They are particularly high in the U.S. For example, O&M costs in 2011 averaged \$0.027 per kWh, but were originally estimated to be \$0.005 per kWh.

A significant amount of research is currently going into gearbox reliability—many gearboxes are failing after 6-8 years in operation.

(Source: *Wind Energy Update — The Wind Energy Operations & Maintenance Report*) BSA extends special thanks to Jaime Lox, Koyo Corporation, for his help in preparing this Industry Brief.

**Recommended Operations and Maintenance Practices**

There is a tendency to focus on blades, gearboxes, and generators but even low value component failures such as a loose bolt can lead to severe revenue losses—making regularly scheduled inspections critical: Visual inspections, blades, videoprobe, thermal imaging, vibration monitoring and oil and grease analysis should be considered. **PTE**

**For more information:**

Bearing Specialists Association (BSA)  
 Phone: (630) 858-3838  
[info@bsahome.org](mailto:info@bsahome.org)  
[www.bsahome.org](http://www.bsahome.org)

Avoiding Downtime and Revenue Loss			
Component	Probability of Component Replacement or Refurbishment	Cost (% of the WTG Cost)	Estimated Downtime (Weeks)
Tower	Very Low	22%	6-10
Hub	Very. Low	16%	4-8
Gearbox	High	14%	2-4
Blade (Individual]	Low	6%	2-10
Generator	Medium	6%	2-4
Yaw Bearing	Low	3%	2-10
Main Shaft searing	Low	2%	2-4

Source: Wind Today Magazine - First Quarter 2011 Issue

