

# Power Transmission Engineering®

OCTOBER 2012

## BACK TO BASICS

WHEN A GOOD  
GEAR DRIVE SYSTEM  
GOES BAD

BEARING SELECTION GUIDE

### Technical

[ Selecting and Sizing Ball Screw Drives ]

[ Gallium Nitride Inverter Drives Motors  
More Efficiently ]

### Case Study

New Conveyor Drives  
Industrial Distribution

### Power Play

*Fingerboarding??*

# Stainless Steel AC Motors

... with IP56 environmental rating



## Ready for washdown and harsh environments!

**IronHorse™** Stainless Steel AC motors are designed for use in applications where motors are frequently exposed to moisture, humidity, certain chemicals or other washdown environments. (*NOT rated for direct contact with food.*) All our Ironhorse motors are in stock and ready for **same-day** shipment; if your order is over \$49, you get **free shipping** too!

### Also Available



- **Cast Iron Premium Efficiency motors** up to 200 hp, starting at \$155



- **Single-phase and three-phase rolled steel general purpose motors** up to 2 hp, starting at \$79



- **Marathon Inverter-duty AC motors** up to 100 hp, starting at \$143

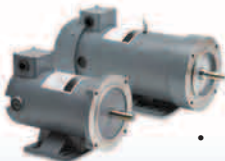

- **DC motors** up to 2 hp, starting at \$133

### Features

- 0.33 to 2 hp, three-phase
- 1800 and 3600 RPM
- Standard NEMA 56C frame
- Available with or without mounting feet
- Totally enclosed, fan cooled
- 304 stainless frame and base; 303 stainless motor shaft
- No restriction on mounting orientation
- IP66 cord grip included

[www.automationdirect.com/motors](http://www.automationdirect.com/motors)



<http://bit.ly/adcmotors>

[www.automationdirect.com](http://www.automationdirect.com)

Go online or call to get complete information, request your free catalog, or place an order.

**1-800-633-0405**



**Order Today,  
Ships Today!**

\* See our website for details and restrictions.  
© Copyright 2012 AutomationDirect, Cumming, GA USA. All rights reserved.



**AUTOMATIONDIRECT**.com  
the #1 value in automation

# Power Transmission Engineering®

OCTOBER 2012

[26]



[28]



[32]



## FEATURE ARTICLES

- [26] **Getting Creative**  
Beverage industry conveyor pours on advantages in distribution center.
- [28] **When a Good Gear Drive System Goes Bad**  
Avoiding catastrophic failure.
- [32] **Got an Application in Need? There's a Bearing for That!**  
Bearing selection guide..

## TECHNICAL ARTICLES

- [36] **Selecting and Sizing Ball Screw Drives**  
Rotary to linear made simple.
- [40] **High-Frequency, GaN Diode-Free Motor Drive Inverter with Pure Sine Wave Output**  
Presenting the first kW-Class, 3-phase GaN-based inverter.

**Transmission expert.**  
**SUHNER**

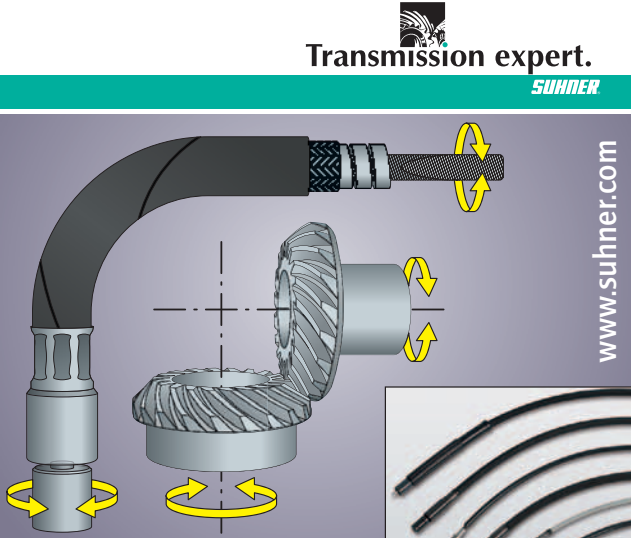

www.suhner.com

## Flexible Shafts & Spiral Bevel Gears

Two different ways to transmit rotary motion.

SUHNER®

SUHNER Manufacturing Inc. · Rome, GA 30161  
Phone: 706-235-8046 · info.usa@suhner.com

# Power Transmission Engineering

VOL. 6, NO. 5

- [04] **PTEExtras**  
Latest online videos, e-mail newsletters and social media
- [06] **Editorial**  
The Things that Move Us
- [08] **Market Update**  
Better Long than Short
- [12] **Product News**  
The latest technology, software and hardware
- [44] **Industry News**  
Announcements, comings, goings and more
- [53] **Calendar**  
Upcoming events of note
- [54] **Ad Index**  
Every advertiser in this issue
- [56] **Power Play**  
Sometimes you just have to make your own fun

## QTC's PRECISION RACKS & PINIONS

**With our large selection of standardized metric gear racks, QTC will meet all of your precision linear motion requirements.**

**Available from stock are racks in modules 0.5 to 10 and lengths of 100, 300, 500, 1000, 1500 and 2000 mm.**

**Our stock gear racks are manufactured to JIS standards using stainless steel, chrome moly alloy steel, carbon steel, brass and nylon.**



**Quality Transmission Components**

**Exclusive North American Distributor of**  
**KHK® GEARS**  
www.khkgears.co.jp/  
**www.qtcgears.com**

Find our products with  
**GLOBALSPEC®**

**Phone: 516.437.6700 • Fax: 516.328.3343**

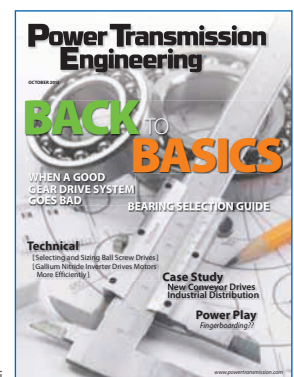

Cover Design by David Ropinski

# Brands YOU Count on People You Trust

U.S. Tsubaki LAMBDA® Chain delivers the ultimate in power transmission technology offering long-term operation without additional lubrication. For packaging, food processing, or any lube-free application or where manual lubrication is unfavorable, LAMBDA® Chain is built for better, longer-lasting performance in maintenance-free operations. Available in drive or conveyor styles, LAMBDA® Chain keeps your operation running clean.

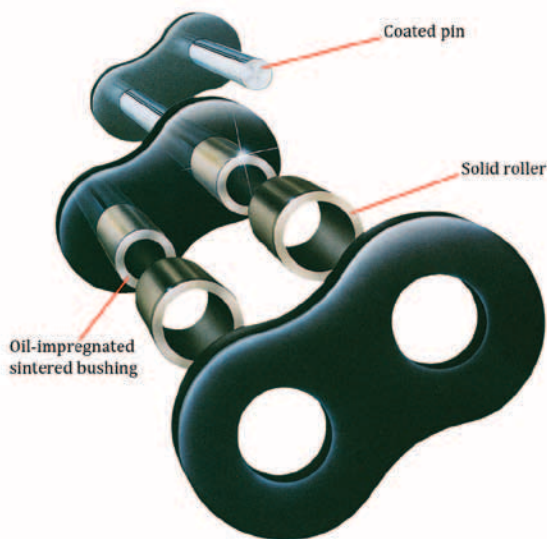

And, you can find U.S. Tsubaki LAMBDA® Chain at your local Motion Industries location. Our local sales and service specialists are experts in application and technical support, providing the parts and the know-how you need to stay up and running.

The brands you count on from the people you trust...that's U.S. Tsubaki and Motion Industries.



Over 500 locations | More than 4 million products  
Industrial maintenance training courses | Call. Click. Visit.



*Keeping Industry in Motion*

1-800-526-9328 for the location nearest you

MotionIndustries.com

## Power Transmission Engineering Videos

Visit [www.powertransmission.com](http://www.powertransmission.com) to see the latest power transmission and motion control videos including instructional product demonstrations, dangerous working conditions for maintenance operators and much more.



This practical instructional video from Motion Industries MiHow2 Series features Rexnord Rotating Equipment Alignment Basics.

## PTE Newsletter

Every month more than 8,500 power transmission and motion control professionals receive PTE's e-mail newsletter which includes exclusive content you can't find anywhere else. Fortunately, you can still read back issues at [www.powertransmission.com/newsletter](http://www.powertransmission.com/newsletter).

Sign up at [www.powertransmission.com/newsletter/subscribe.htm](http://www.powertransmission.com/newsletter/subscribe.htm)



Ernie Reiter (Chairman, AGMA Plastics Gearing Committee) and Mike Cassata (Winzeler Gear) discuss the benefits of plastic gearing with Senior Editor Jack McGuinn in the October 2012 newsletter.

Associate Editor Matthew Jaster examines product highlights from Industrial Automation North America (IANA) exhibitors at IMTS in the September newsletter.



## Stay Connected with Social Media



Follow us on Twitter  
[twitter.com/#!/PowerTransMag](https://twitter.com/#!/PowerTransMag)



Connect with us on LinkedIn  
<http://www.linkedin.com/groups/Power-Transmission-Engineering-PTE-2950055>



Subscribe Online  
[www.powertransmission.com/subscribe.htm](http://www.powertransmission.com/subscribe.htm)

The *Power Transmission Engineering* Facebook page features two IMTS photo albums taken by David Ropinski, art director, setting the scene for the largest U.S. manufacturing show in ten years.

<http://www.facebook.com/pages/Power-Transmission-Engineering/109042075794176>

# Power Transmission Engineering

## Randall Publications LLC

1840 Jarvis Avenue  
Elk Grove Village, IL 60007  
Phone: (847) 437-6604  
Fax: (847) 437-6618

### EDITORIAL

#### Publisher & Editor-in-Chief

Michael Goldstein  
[publisher@powertransmission.com](mailto:publisher@powertransmission.com)

#### Managing Editor

Randy Stott  
[wrs@powertransmission.com](mailto:wrs@powertransmission.com)

#### Senior Editor

Jack McGuinn  
[jmcguinn@powertransmission.com](mailto:jmcguinn@powertransmission.com)

#### Associate Editor

Matthew Jaster  
[mjaster@powertransmission.com](mailto:mjaster@powertransmission.com)

#### Editorial Consultant

Paul R. Goldstein

### ART

#### Art Director

David Ropinski  
[dropsinski@powertransmission.com](mailto:dropsinski@powertransmission.com)

### ADVERTISING

#### Advertising Sales Manager

Dave Friedman  
[dave@powertransmission.com](mailto:dave@powertransmission.com)

#### Materials Coordinator

Dorothy Fiandaca  
[dee@randallpublications.com](mailto:dee@randallpublications.com)

### CIRCULATION

#### Circulation Manager

Carol Tratar  
[subscribe@powertransmission.com](mailto:subscribe@powertransmission.com)

### RANDALL PUBLICATIONS STAFF

#### President

Michael Goldstein

#### Accounting

Luann Harrold



# The First Name in Power Transmission



**BALDOR • DODGE**

Baldor • Dodge® power transmission products offer reliable service and low maintenance to help reduce your total cost of ownership. Our innovative bearings, gearing and power transmission products have solved the toughest applications for over 125 years.

Our technical sales team can help you with the most challenging applications, and our worldwide distributor network ensures immediate delivery.

When it comes to PT solutions, Baldor • Dodge is the first name in power transmission.

[baldor.com](http://baldor.com) 479-646-4711

- Unmatched Quality
- Superior Reliability
- Improved Uptime
- Quick Delivery

**BALDOR**<sup>®</sup>  
A MEMBER OF THE ABB GROUP

# The Things that *Move* Us

You may have noticed that the magazine looks *different* this issue. The new look is part of an overall effort to refine our focus. We wanted to make clear to potential subscribers and advertisers how this magazine is different, why its content is important and where it fits in the marketplace.

We looked long and hard in the mirror. We reexamined our editorial mission. And then we sought the advice of our readers and advertisers to learn how we can best serve the industry.

The issue you're reading is the result.

Although many of the changes you'll notice right away are cosmetic changes—designed to make it easier to navigate, read and understand—the most significant is the change to our logo. The logo represents our brand: who we are and what you can expect to find in our magazine. The old logo emphasized our initials. The new one emphasizes each word: *Power. Transmission. Engineering.*

The phrase “Power Transmission” is important because it sets us apart from all other magazines. Most of you are inundated with mail. The magazines pile up and get thrown away before you ever have a chance to read them. But we want to be the magazine that escapes the pile, the one that's set aside because it's important to you. Admittedly, many of those other magazines cover topics similar to our own. Most talk about design engineering, plant operations or manufacturing in a general way. But none of them have the same unwavering focus that we have. Whereas many of these other magazines tend to ignore or gloss over power transmission components and their applications, we embrace them. *Power Transmission Engineering* is the magazine about the technical aspects of mechanical components, and our redesign reflects that focus—starting with the new logo.

The “Engineering” part of our name is also an important part of who we are. We run technical articles. We explain the fundamentals, because you can't design, specify or buy power transmission components without understanding how they work.



So if you're a design engineer involved with specifying gears, bearings or motors, this magazine is for you. If you're an end user whose machinery requires you to understand gearboxes, clutches and couplings, this magazine is you. If you are a manufacturer whose products include mechanical power transmission components, this magazine is for you.

We're committed to providing the information you need to make smart decisions when it comes to specifying or buying these components, whether you're building a brand new machine or upgrading existing equipment.

Mechanical power transmission components are what we know. As many of you are probably aware, we've published *Gear Technology* since 1984. So gears have always been a part of who we are. In 1997 we introduced *powertransmission.com* as a comprehensive online buyers guide for mechanical components. (We're in the process of fine-tuning *powertransmission.com* with the same rigor we've applied to the magazine, so stay tuned for updates over the coming months.)

Gears, bearings, motors, couplings, clutches. These are the things that move the world. But they're also the things that move *us*. We hope they move you, too, and that you'll continue to support us by reading the magazine. **PTE**

Randy Stott, Managing Editor

P.S. If you have any specific suggestions or comments regarding our change of look, our refocused editorial mission or things you'd like to see in the future, we welcome your feedback. Send e-mail to [wrs@powertransmission.com](mailto:wrs@powertransmission.com).



# Mars Rover Curiosity

★ discovers what she's made of

ooo00000ooooh...

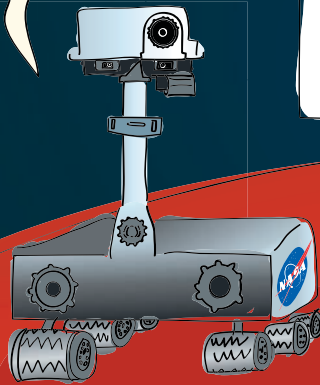

Scan here to visit our new website and find out  
Or visit [forestcitygear.com](http://forestcitygear.com)

Roscoe, IL | 815-623-2168 | [www.forestcitygear.com](http://www.forestcitygear.com)

**FOREST CITY GEAR**

# Better Long than Short

Brian Langenberg, CFA

### Third-quarter activity has slowed.

Fears of a “fiscal cliff” and a presidential election are combining to drive (mostly) negative news flow in the media and, indeed, on the margin—a sluggish 3Q economy. We anticipate most industrial companies will miss revenue forecasts while “meeting” Street estimates on cost cutting and lower material prices. We also expect cuts to earnings guidance for 2012 and a cautious tone on 2013, reflecting a combination of current softness, fears of fiscal cliff and—possibly—election year preference for “change.”

**But underlying economic activity remains positive—particularly in the U.S.** We point to record attendance and brisk machinery sales at IMTS in Chicago this year, rising residential construction activity and continued spending in resource end markets (oil, gas, minerals), with only pockets of weakness, along with commercial aerospace.

We also anticipate inventory re-stock and that necessary capital spending will continue to drive at least modest overall gains in 2013.

**Europe—same-o, same-o.** Europe has modestly downshifted, but high

commodity prices continue to drive demand in Scandinavia, Russia and most of Northern Europe. The problem children remain: Spain, France (but only a nuisance to itself) and noise.

**China is likely to accelerate in the second half of 2013.** In the near-term, pockets of overcapacity persist (non-residential construction near the coast, excavators) and the export model is shifting. And, labor unrest continues (another incident at Apple supplier Foxconn), even as a new leadership generation prepares to take power. Many view this with concern; but *we* see it pointing to rising levels of capital spending.

**Our one-year base S&P 500 forecast is 1,650—up 15 percent.** We assume 2013 S&P earnings climb to \$105 from the current \$93 (trailing 12 months)—below the current-but-declining consensus of \$112 and above



Ksawery Langenberg (age 12) demonstrates proper use of a Nintendo DS3 at IMTS 2012.

the \$93 fiscal cliff scenario espoused by some (Table 1).

**Deal with it: elections matter.** Simply relying on guidance and current fundamentals would be an ignorant way to make calls on industrials—or any other sector—less than a month before a presidential election.

We do not know who is going to win. And neither do you. This is why everybody is sitting on his or her hands. But we do know how to think and map out various scenarios in which the upside case is stronger than the downside case for these reasons:

- **Demand is rising.** Housing is up—not a lot, but up—as is employment (though anemic and way below potential), energy investment, the global aerospace cycle, and construction activity to name a few.
- **Natural gas is the new COD.** A plentiful, cheap natural resource that has structurally improved the U.S. competitive position in manufacturing.
- **Fiscal cliff scenario really a pothole.** Obama is open to attempting to keep taxes lower for the majority of the population and would love to spend on infrastructure.
- **Near-term investment pull-back = pent-up/delayed demand—but not destroyed.**

S&P 500:		1456					
		S&P 500 Earnings					
P/E	\$93	\$105	\$112	Price Return			
14x	1,302	1,470	1,568	(11%)	1%	8%	
15x	1,395	1,575	1,680	(4%)	8%	15%	
16x	1,488	1,680	1,792	2%	15%	23%	
17x	1,581	1,785	1,904	9%	23%	31%	
18x	1,674	1,890	2,016	15%	30%	38%	

SKY IS FALLING	S&P 500	Impl. Ret.
5/6/09 Armageddon	683.38	(53)%
8/19/11 US Downgrade	1123.5	(23)%

Table 1

In the past month or so we've attended the IMTS trade show, SPX Corp, Oshkosh Corp, GE, Tyco, Kennametal and Tyco International. Our take: we remain in a recovery with significant pent-up demand.

- **High corporate cash and deal activity.** Plenty happening, and multiples remain high for a reason.
- **Americans are stubborn.** Growth is happening despite gridlock, regulatory hostility, a diabolically cynical public education establishment, unwillingness of banks to lend and a tax code that drives investment offshore.

There are downside scenarios, more cliff than we're aware of—i.e., a slower China driving a 10 percent decline—and we illustrate a couple disaster-like price moves. But the latter do not strike us as realistic.

**We are not betting on multiple expansion.** The S&P traded in the high teens for most of the slow-growth era in the mid-late 1950s; i.e., financial repression before competing demands for capital on two fronts—Vietnam and social spending—eventually drove inflation and lower multiples.

This time is different, owing to obvious budgetary challenges, e.g.—entitlements, cash-strapped state governments, pent-up capital requirements on infrastructure. Though we've opted not to put in another chart, an example: equity investors from 1966–1982 did not make any money, adjusted for inflation—ouch!

But staying out of the market in fear of contraction has proven costly for many. The market's earnings/free cash flow yield is nearly 7 percent, compared to 2 percent U.S. 10Y Treasuries. Obviously the market is already pricing in a significant combination of risk and future inflation. In theory the current market multiple would correlate to a treasury yield of 6–7 percent.

- **Commodities.** High—and staying there. Scramble for resources will continue and is showing up in geopolitical tension in multiple regions.
- **Wages.** Going nowhere in the U.S.—but rising in emerging markets. A positive for capital goods: more capital spending to substitute capital for labor.
- **Interest rates.** Low for the foreseeable future. The U.S. dollar is

the safe haven big enough to absorb fear.

In terms of an investable horizon (not trade)—be it 3–5 years, 1 year or a 6–9 month trade—the rational course of action is to assume interest rates, wage growth (ex public sector unions?) and general price inflation remain quite low.

Is there a long-term problem? Of course. And it hits right when I turn 65.

**The glass is at least half-full—and there is no hole in the glass. While fiscal cliff disaster is a possibility, we're thinking more fiscal pothole.**

But that is in 2028, and we have few requests to discuss our 14-year forecast.

**Let's review market and interest rate history along various periods.** Starting from a period (1975) with high rates of inflation in commodities, wages and general price levels.



[www.circlegear.com](http://www.circlegear.com)

**Circle Gear and Machine**

1501 South 55th Ct. • Cicero, IL 60804  
Ph: 708-652-1000 • Fax: 708-652-1100

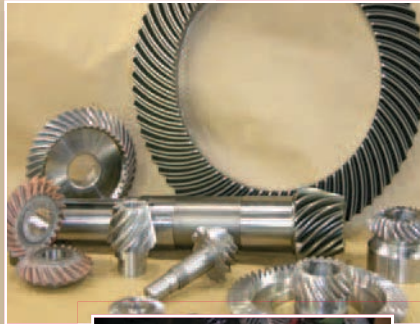

- **Quality Custom Gearing**
- **All Gear Types and Sizes**
- **ISO 9001:2008 Certified**
- **Reverse Engineering**
- **Design Analysis**
- **Nationwide Service Since 1951**

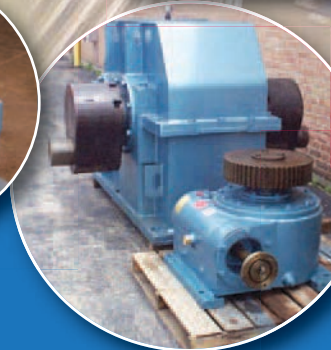
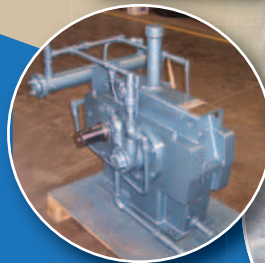

**GEARBOX  
REPAIR  
SPECIALISTS**

- **Prompt, accurate quotations**
- **Competitive pricing**
- **Quality repairs/rebuilds**

**Quality Reducer Service**

620 East Avenue ■ LaGrange, IL 60525  
708-354-8080



**WE SERVICE ALL TYPES OF INDUSTRIAL GEARBOXES**

[www.qualityreducer.com](http://www.qualityreducer.com)

**Table 2 S&P 500 – Jimmy Carter to Present**  
 Blue/Left scale – S&P500  
 Red/Right scale – U.S. 10-Year yield

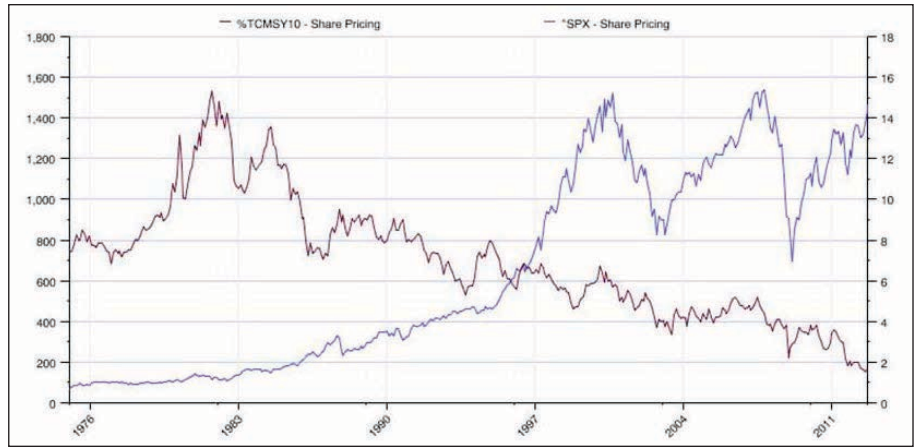

**Table 3 S&P 500 – New Millennium to Present**  
 Blue/Left scale – S&P500  
 Red/Right scale – U.S. 10-Year yield

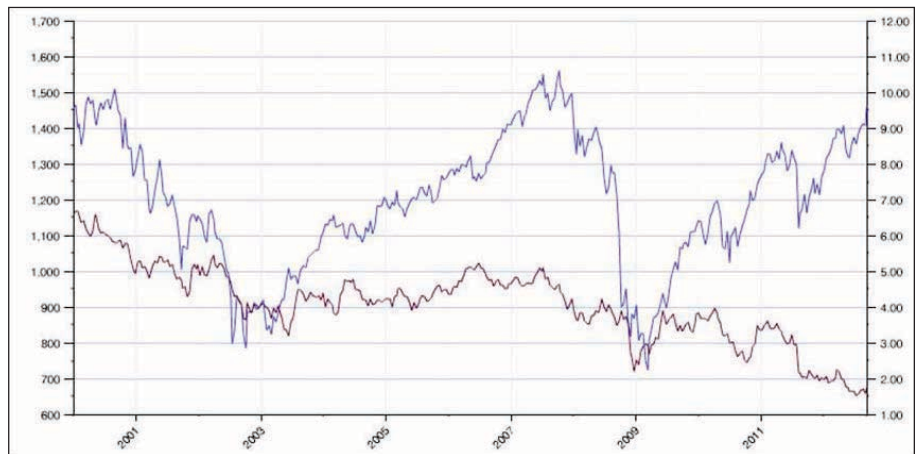

**Table 4 S&P 500: In Fed We Trust (Hope) to Present**  
 Blue/Left scale – S&P500  
 Red/Right scale – U.S. 10-Year yield

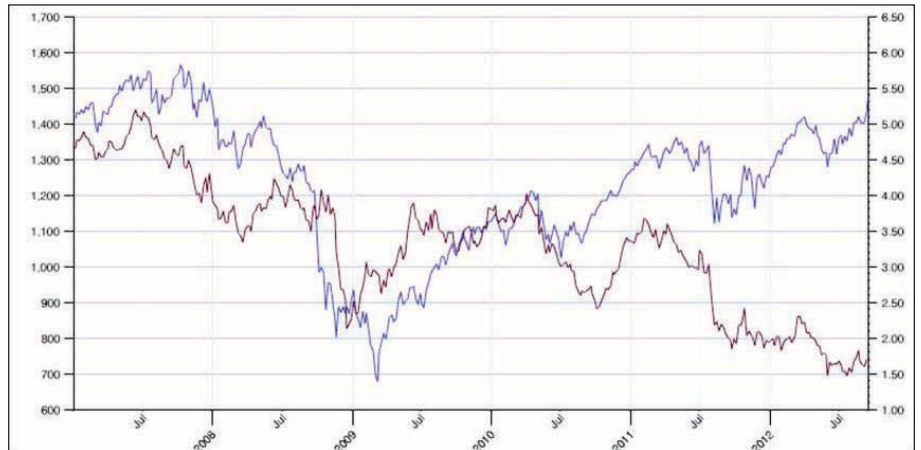

**Table 5 S&P 500: 11 Aircraft Carriers to Present**  
 Blue/Left scale – S&P500  
 Red/Right scale – U.S. 10-Year yield

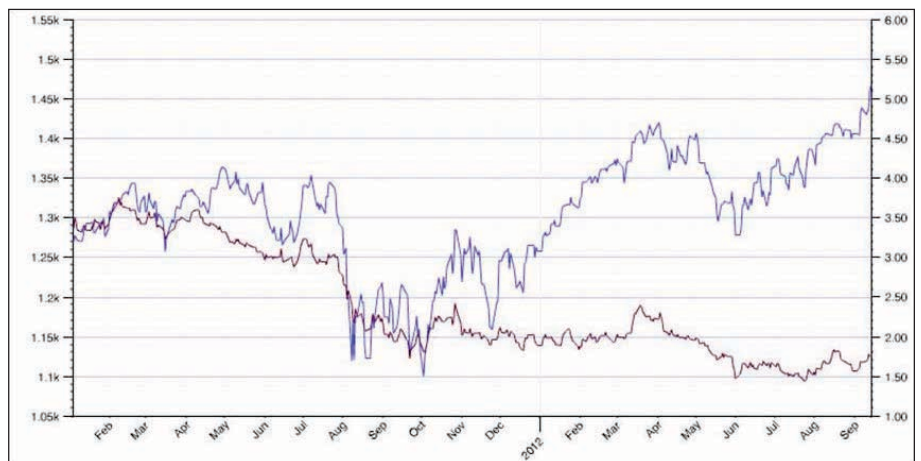

We all know what happened (if at least 45 years of age!). Jimmy Carter (Obama 1.0) loses to Ronald Reagan who crushes the PATCO (air controller) strike, lets Paul Volcker raise rates to get inflation under control and eventually defeats the Soviet Union. Meanwhile, interest rates go from 15 percent (really 8 percent before being raised first) to 2 percent, which tends to support financial markets and multiples (Table 2).

Sure—we are all looking at that 1998–2012 trading range and suspect it is keeping a lot of cash on the sidelines. But we note the lows were driven by full-fledged downturns; e.g., in 2002 the culmination of September 11/tech bubble/Asia meltdown/recession, and the obvious financial meltdown that hit the market with full force in 2009.

Here is another look starting from 1/1/2000; an easy-money era as rates have declined from 6–7 percent to 2 percent would suggest the market has an upper cover on it.

In our view, a major reason so many investors are sitting on their hands is some variant of Table 3. Yet one can argue this is a fundamentally better market: the tech bubble era saw unusually high multiples on the S&P, driven by stratospheric multiples on tech darlings that in combination with large weightings softened the indexes whack.

“Normal company” multiples were in fact similar to current levels. Prior peaks were built on sand; i.e.—whether unrealistic expectations in 2000 or leverage and hubris in 2007. This one is different; we are near prior market peaks with everybody scared out of their wits and it shows; e.g.—equity risk premium of 500 basis points (Table 4).

And finally—the 2011 downgrade by S&P of U.S. debt. Long-term S&P has a legitimate point; markets, after an initial panic, figured out that flight to quality means *buying* the debt and currency of a nation that can afford 11 aircraft carriers (Table 5).

The market discounts significant—if not dramatic—risk. While the structural programs and political/societal debates likely preclude multiple expansion, in turn the earnings picture is constructive and the case for multiple compression quite weak.

**Overall, we remain in a slow economic expansion.** The glass is at least half-full—and there is no hole in the glass. While fiscal cliff disaster is a possibility, we’re thinking more fiscal *pothole*, because even President Obama is seeking to maintain lower taxes on the majority of the U.S. population—at least in the near-term—and there will be bipartisan desire not to drive the U.S. economy into a full-scale recession. **PTE**

**Brian K. Langenberg, CFA,**

has been recognized as a member of the Institutional Investor All-America Research Team, a Wall Street Journal All-Star, and Forbes/Starmine (#1 earnings estimator for industrials). Langenberg speaks and meets regularly with CEOs and senior executives of companies with over \$1 trillion in global revenue. His team publishes the Quarterly Earnings Monitor/Survey—gathering intelligence and global insight to support decision-making. You can reach him at [Brian@Langenberg-llc.com](mailto:Brian@Langenberg-llc.com) or his website at [www.Langenberg-LLC.com](http://www.Langenberg-LLC.com).



**LIGHT YEARS AHEAD**

IT'S THE DAWN OF A NEW ERA FOR GEAR MANUFACTURING.  
AND SCHAFER IS LEADING THE WAY.

A progressive gear manufacturer understands it needs to go above and beyond traditional expectations. Today's customers demand – and deserve – the latest technology, a wide range of capabilities and an unrelenting commitment to prompt and effective customer service. When it comes to exceeding expectations, Schafar Gear is truly light years ahead. Our investment in the latest production equipment assures that we can provide gears for many industrial applications including transportation, medical, mining, gas and energy, agricultural equipment and many specialty applications. And every gear we make comes with one thing standard – the willingness to go to the ends of the earth to serve our customers well.

**SCHAFER**  
GEAR WORKS, INC.

Find out more at  
[www.schafargear.com](http://www.schafargear.com) or  
call us at 574-234-4116.

# Baldor

INTRODUCES EXL BEARINGS,  
EXPANDS DC MOTOR LINE

Baldor Electric Company introduces the new Dodge Type EXL tapered roller bearing that provides both misalignment and expansion capability, while maintaining industry standard Type E mounting dimensions. This new design incorporates a cartridge-style inner unit into a split ductile iron housing.

The split-housing design allows the inner unit to swivel freely in the housing, allowing up to  $\pm 4$  degrees of static misalignment. Standard Type E products offer virtually no misalignment and are not available in an expansion design. Mounting dimensions are equivalent to any standard Dodge or competitor's Type E dimensioned product. The totally sealed inner unit incorporates the Dodge XTS triple-lip seal for increased protection in harsh environments. The housing is made from ductile iron for added strength versus cast iron products.



The Type EXL utilizes the new Dodge tapered roller bearings manufactured in Marion, North Carolina. The new bearing design offers a 13 to 14 percent increase in load ratings over the previous tapered bearing design. The new design is available in both two- and four-bolt pillow blocks and utilizes the same inner unit for both expansion and non-expansion housings. Bore sizes range from  $1\frac{3}{16}$  to 5 inches. The Dodge Type EXL will increase reliability and decrease downtime by offering better sealing, misalignment capability and load ratings versus the competition.

Additionally, Baldor now offers customers the widest variety of permanent magnet and wound field industrial DC motors in the world. Both IEC and NEMA frame motors are avail-

able from stock from  $\frac{1}{50}$  to 500 hp, and Baldor meets specific application needs with custom-designed motors up to 3,000 hp. While other manufacturers have left the DC motor market, ABB and Baldor continue to invest in DC product development and U.S. manufacturing. A complete offering of Baldor round body DC motors has the same shaft height and mounting dimensions as competitors' motors, making the Baldor product an easy drop-in replacement. Baldor also offers a full range of laminated frame DC motors, including explosion proof designs. ABB's DMI DC motor is the most power dense DC motor design in the global market. This laminated frame IEC product has ratings up to 1,400 kW, and with its smaller footprint can be used in a variety of applications where space is an issue.

**For more information:**

Baldor (A member of the ABB Group)  
5711 R.S. Boreham, Jr. St.  
Fort Smith, AR 72901  
Phone: (479) 646-4711  
[www.baldor.com](http://www.baldor.com)



# Nord Gear Motors

POWER AGGREGATES  
PRODUCTION UNIT

The IECS Company, specializing in the manufacture, assembly, and maintenance of quarry and sand pits equipment, has chosen Nord gear motors to power the new aggregates production unit of the Pradier Group. The French Group Pradier produces 400,000 tons of concrete blocks and interjoists per year, which are intended for building material suppliers. Pradier Carrières, founded in 2010, has thus opened its first operating site in 2011 in Mondragon in the south of France. The quarry consists of a deposit of about 375 acres and 20 million tons of ore, with a mining permit for 450,000 tons per year over 30 years. 350,000 tons are then transported by road and 100,000 tons by river. The processing plant is located near the deposit (1 km by conveyor) and has a production capacity of 400 tons per hour.

The IECS Company completed the whole installation, which provides ore

crushing, screening, and conveying of aggregates to their shipping points. "We buy Nord Drivesystems helical bevel gear motors regularly," says Cachot, IECS manager. In total, there are 37 Nord Drivesystems helical bevel gear motors, SK9042.1 & SK9072.1 models powered by IEC B5/IE2 motors used in the Pradier site. "We have a very good relationship with Nord. It is a human-sized company, they are very reactive. When we commissioned the facility, the motor model had to be changed for two units which ratings were not high enough. We called Nord and 36 hours later it was changed. The Nord sales manager is always available to help on the project, he reacts very quickly. The company stands out by its very high reactivity. A new emergency assembly and shipping service is offered to all customers since the spring of 2011. Whether it's a motor or a gear motor, with or without variable frequency drive, painted or not, the company undertakes, provided the components are available, to assemble and ship on the same day anywhere in France, and this for all orders placed

before 4:30 pm. To achieve this fast response time, the processes, inventory levels and logistics were thoroughly reviewed in 2011. The same service has been set up for spare parts."

Energy consumption was obviously an important aspect of the facility. Again, Nord stood out by offering IE2 motors. To comply with new and more demanding standards, in terms of energy efficiency, Nord has made many improvements to its IE2 motors. For example, superior materials are used in the stator, the quality of the plates is better, more copper was used and the windings have been optimized. These efficient motors are naturally beneficial to users. In addition to better performance, the motors run cooler and have a longer operating life. These improvements also result in greater power reserve, which opens up new possibilities in terms of drive systems design.

## For more information:

Nord Gear Corp.  
300 E. Forsyth Hall Dr  
Charlotte NC 28273  
Phone: 1-888-314-6673  
[www.nord.com](http://www.nord.com)



## EXCEL GEAR, INC.

GEARS 1"-60" - AGMA 15

The **EXCEL** promise;

*We'll excel where others fall short.*

- Complete gear design, manufacturing and reverse engineering services
- Gear hobbing & grinding from 1"-60" (To AGMA 15)
- Internal gear grinding from 10"-60"
- Gear shaping to 36" diameter (9" face width)
- Wind turbine gear boxes, high speed spindles, gimbal heads and gear boxes
- Competitive prices and quality gear design and manufacturing with delivery commitments you can count on!

**A TOTAL SERVICE COMPANY**  
ISO9001-2008 APPROVED

### Introducing Excel-Lent Gear Design Software

providing accurate gear design and analysis that can get anyone up and running fast—[www.excel-lentsoftware.com](http://www.excel-lentsoftware.com)

**815-623-3414**

[quotations@ExcelGear.com](mailto:quotations@ExcelGear.com)

**[www.ExcelGear.com](http://www.ExcelGear.com)**

# Sakor

OFFERS TURN-KEY DYNAMOMETER TEST CELLS

Sakor Technologies, Inc. provides complete turn-key test cells for engine, powertrain and component testing. At the heart of each test cell design is the DynoLAB PT data acquisition and control system, which seamlessly integrates external devices, including dynamometers, throttle actuators, spark & fuel controllers, combustion analysis systems, emission analyzers, and other smart I/O devices, into a single, coherent test system.

Based on individual customer requirements, Sakor engineers select each of these components, as well as all sensors, actuators, and any necessary cell mechanics including cooling systems, fuel conditioning systems, couplings, drive-shafts, guards, bed plates, dynamometer bases and docking carts, to build the ideal test cell equipment for each customer's specific needs. Sakor also offers complete cell upgrade services.

The DynoLAB PT system is specifically designed to work with all types of dynamometers. Sakor can provide its customers with any type they desire; however, for maximum performance, the Accudyne line of AC motoring dynamometers is recommended. Accudyne dynamometers offer full 4-quadrant operation with seamless transition between loading and motoring modes. The combination of a DynoLAB PT with an Accudyne dynamometer is perfect for performing road-load simulation as well as race track simulation, transmission testing, and other applications that require both driving and loading.

Whether dealing with performance evaluation, drivetrain and component durability testing, in-use simulation, quality control, catalyst performance and aging studies, or other dynamometer based testing, Sakor Technologies designs and builds quality and affordable dynamometer test cell systems tailored to each customer's specific needs.

**For more information:**

Sakor Technologies, Inc.  
2855 W. Jolly Road  
Okemos, MI 48864  
Phone: (517) 332-7256  
[www.sakor.com](http://www.sakor.com)

# R+W

OFFERS EKZ INTERMEDIATE SPACERS

Servomax elastomer couplings from R+W feature a specially calibrated polyurethane insert, which is preloaded between precision machined driving jaws. In addition to their high torque density, low cost and quick availability, they are used for vibration damping, shock absorption and compensation for some small amounts of shaft misalignment. Occasionally, machine layouts and mounting arrangements simply



do not allow for installers to achieve the alignment specifications of the standard series. This can cause stress to be transferred across the coupling and insert and onto adjacent shaft bearings, leading to premature wear. For these situations R+W is now offering the EKZ intermediate spacers, for use in high misalignment applications. Since parallel-shaft misalignment is compensated for by an angular flex across each insert, the tolerance is actually increased by far more than double with the EKZ spacer, in some cases allowing for 4-5x more offset than with single insert designs. Even larger amounts of misalignment can be compensated for with a special convex tooth insert, which allows for additional rolling action as the coupling jaw pivots over the insert rather than causing it to flex. The standard EKZ product line ships from stock and is available in nine sizes, with torque ratings from 0.5 up to 2,150 N-m. They can fit any style of R+W Servomax elastomer jaw coupling of the corresponding size.

**For more information:**

R+W America  
1120 Tower Lane  
Bensenville, IL 60106  
Phone: (888) 479-8728  
[www.rw-america.com](http://www.rw-america.com)





# Der Servo.

Precise German engineering, *customized for your application*



**Dunkermotor Shines**  
With expertise gained from over 150,000 units in the solar field, download brochures at [www.dunkermotor.com/STM](http://www.dunkermotor.com/STM)

○ GEARHEADS  
Planetary  
Low-Backlash Planetary  
Worm  
To 1400+ in-lbs (160 Nm)  
Compact, lightweight, high efficiency

○ MOTORS  
DC Brushed, Permanent Magnet  
DC Brushed, Permanent Magnet w/ Integral Speed Control  
DC Brushless  
DC Brushless, w/ Integral Speed Control  
DC Brushless, w/ Integral 4Q Servo Control  
AC, single- and three-phase  
To 0.67 hp (500W)  
Protection to IP69K

○ CONTROLS  
  
  
  
  
Integrated PLC

○ ENCODERS AND BRAKES  
Optical and Magnetic Incremental  
Absolute: Single and Multi-Turn  
Integrated and External  
To 1024 PPR

Call on the global quality and value leader.

Now part of AMETEK Precision Motion Control, and recognized since 1950 as the world market leader in customized, configurable sole-source fractional horsepower motion control solutions. Today it's easier than ever to tap into the in-depth application knowledge and skills of the team of 1,000 that produced 3.4 million motors last year for the automation, medical, solar, packaging, special vehicle and very likely your own particular industry segment.



Learn more about Dunkermotor products in solar tracking and power plant applications.



P: 224-293-1300  
[www.dunkermotor.com](http://www.dunkermotor.com)  
[info@dunkermotor.com](mailto:info@dunkermotor.com)



# Pittman Motors

OFFERS MICROMOTORS FOR MEDICAL DEVICES

Pittman Motors, a division of Ametek/Precision Motion Control, offers high-performance slotless brushless DC motors for medical applications, such as high-speed surgical tools, dental tools, medical instruments and other small medical devices. As the medical industry trends away from pneumatic devices and moves toward DC motor platforms, motor design and manufac-

turing requires a new level of technology to meet demanding medical applications.

In addition to their small size, Pittman high-performance slotless brushless motor designs offer many benefits that are well suited for medical applications. These miniature motors are capable of very high speeds, produce little or no EMI emission (electromagnetic interference), provide long life, and have low audible noise. In addi-



TAKE THE PRACTICAL APPROACH.

MADE TO FIT. SIMPLE TO INSTALL. SMOOTH RUNNING.



**R+W**  
COUPLING TECHNOLOGY  
THE PERFECT COUPLING  
WORLDWIDE.

R+W America | Phone: (888) 479-8728 | E-Mail: info@rw-america.com | Internet: www.rw-america.com

tion, the slotless design eliminates magnetic cogging. In Pittman slotless brushless motors, the stator teeth are completely eliminated by forming and encapsulating the entire stator winding along the inside surface of the back iron. The result is zero detent torque, low inductance and fast response rates.

Pittman's smallest high-performance motor is 0.375" (9.53 mm) with a maximum speed of up to 70,000 rpm and a torque rating of up to 0.3 oz-in (0.002 N-m). Overall length is 2.00" (50.8 mm). The motor has a two pole permanent magnet rotor, a three phase stator and sensorless commutation. Larger diameters in the high-performance line include 0.5" (12.7 mm), 0.8" (20 mm), and 1.1" (28 mm). Maximum speeds are available up to 60,000 rpm and torque ratings from 0.9 oz-in (0.006 N-m) to 14.9 oz-in (0.105 N-m). Each diameter has 2 available stack lengths. The motors are constructed using four pole rotors, three phase stators, and integral hall sensor feedback spaced for 120 electrical degrees.

Standard features for the high-performance DC motor offering include shielded ball bearings, stainless steel construction and high-energy neodymium rotor magnets. Permanent magnet rotors are balanced for smooth and quiet operation at high speeds. Autoclavable versions are available in all motor sizes.

**For more information:**

Pittman Motors  
A Division of Ametek/Precision Motion Control  
627 Lake Street  
Kent, OH 44240  
Phone: (215) 256-6601  
[www.pittman-motors.com](http://www.pittman-motors.com)

# CUSTOM

## BEVEL GEAR MANUFACTURING

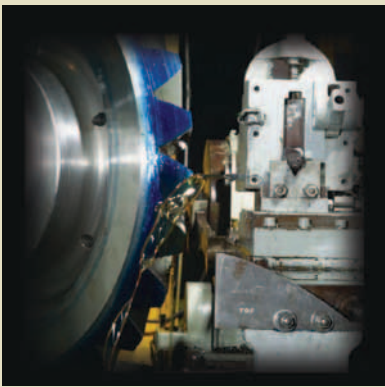
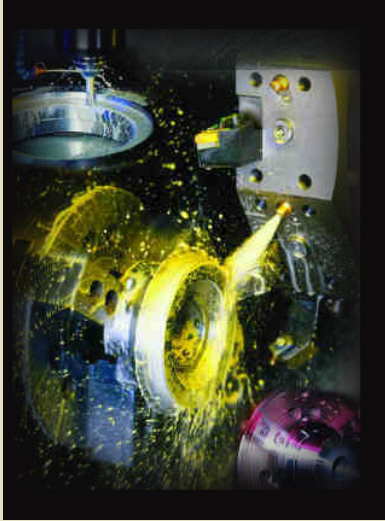

**INVERSE ENGINEERING**

**BREAKDOWN SERVICES**

**IN-HOUSE STEEL MATERIAL WAREHOUSE**  
**STRAIGHT BEVEL GEARS: 80" PD**  
**SPIRAL BEVEL GEARS: 66" PD**  
**FULL HEAT TREATING SERVICES**  
**SPURS, HELICALS, SPLINE SHAFTS**  
**GEARBOX REPAIR/REBUILDS**  
**EDM WIRE BURNING**

# B&R

**Machine and Gear Corporation**

**Toll Free: (800) 238-0651**  
**inquiry@brgear.com • www.brgear.com**



## Stafford

OFFERS ADJUSTABLE MOUNTING SHAFT COLLARS

A line of adjustable mounting shaft collars that can be customized for securing sprockets, pulleys, lever arms and other drive components is available from Stafford Manufacturing Corp. of Wilmington, Massachusetts. Stafford Accu-Mount Collars provide a square and rigid method for mounting components such as sprockets, gears, pulleys and lever arms to a shaft and are adjustable for easy repositioning. Featuring one solid square and flat side along with a centering hub and second side that securely clamps to a shaft, these



mounting collars come standard with four mounting holes.

Available in steel, stainless steel, and aluminum, Stafford Accu-Mount Collars are offered in 11 sizes from 1/2" to 2" I.D. and can be customized with different mounting hole patterns or special configurations to precisely match user requirements. These split collars have a smooth bore to protect expensive shafts and can be supplied with or without a keyway. Stafford Accu-Mount Collars are priced from \$35.00 (list), depending upon size. Price quotations are available upon request. Stafford Manufacturing is ISO 9001:2008 Certified.

**For more information:**

Stafford Manufacturing Corp.  
256 Andover Street  
Wilmington, MA 01887  
Phone: (800) 695-5551  
[www.staffordmfg.com](http://www.staffordmfg.com)

## Ogura

RELEASES THIN PROFILE MICRO CLUTCH

The new MIC-T series clutches from Ogura offer customers significant size, weight and cost savings over the previous series of MIC clutches. In some cases, depending upon volume, cost can be half of previous versions, allowing significant savings for customers producing consumer and business printers and copy machines. The new clutches are available with either a customer specified gear or a dog hub output, which allows customers to purchase one clutch and then incorporate

a number of different gears for their different needs. The clutches have achieved the cost and weight reduction by changing basic clutch construction utilizing an all plastic and powder metal design. Clutches are supplied with lead wire and terminal. Ogura has been producing clutches and brakes since 1938 and the have developed over 5,000 different models of clutches and brakes. Although Ogura primarily produces electromagnetic clutches and brakes, they also produce magnet

particle, mechanical, pneumatic, hydraulic and a variety of specialty products. Ogura is the world's largest manufacturer of electromagnetic clutches and brakes. Current manufacturing capacity is over 30 million units per year. To provide localized support, we



have fourteen manufacturing plants spread throughout the world in Asia, The Americas and Europe. All manufacturing facilities are ISO recognized and conform to the ISO 9001:2008, ISO 14001 and ISO/TS 16949.

**For more information:**

Ogura Industrial Clutch  
P.O. Box 5790  
Somerset, NJ 08875  
Phone: (732) 271-7371  
[www.ogura-clutch.com](http://www.ogura-clutch.com)

## Altra

FEATURES PRODUCT LINES AT TURBOMACHINERY SYMPOSIUM

Altra Industrial Motion brands Ameridrives Couplings, TB Wood's and Bibby Turboflex, displayed their latest product lines in booth 1221 at this year's Turbomachinery Symposium in Houston, Texas. Visitors learned about Altra's broad range of products that can be applied to improve efficiency, productivity and safety in all types of turbomachinery applications including gas and steam turbines, compressors, pumps, generators, motors, fans and blowers.

Featured products included Ameriflex high-performance diaphragm couplings designed for high-torque densities and large misalignments and Ameridisc high-performance, dependable, low-maintenance couplings. Bibby Turboflex disc couplings, designed to meet the ever-increasing demands of today's high-speed turbomachinery, were



also on display. Other exhibited solutions included Torsiflex-i disc couplings which are specifically designed for process pump applications and maintenance-free Dura-Flex and Sure-Flex elastomeric couplings.

In addition, Altra Industrial Motion brands Wichita Clutch and Twiflex Ltd. will be exhibiting their state-of-the-art braking technologies at this year's International Tidal Energy Summit in London (November 28-29). Twiflex Ltd. will be featuring their line of spring-applied and direct-acting, pneumatic or hydraulic, caliper disc brakes which provide routine dynamic stopping, holding or emergency stopping functions. Models may be customized with a variety of features and finishes suitable for tidal turbine drive applications and packaged with discs and controls where required. Wichita Clutch will showcase their 'Wet' plate brakes which generate torque through shearing of the oil layer, with negligible lining wear, and are therefore ideal for the low maintenance requirements of sub-sea installations. Similar 'dry' units are also available, including water-cooled versions for high-energy stop applications. For the tidal energy industry, together these brands provide a single source for engineered solutions with a proven track record in supplying compact, robust, reliable, and low-maintenance products. With several brake packages installed in pre-commercial tidal turbine demonstrators including the EMEC test facility, leading Altra brands Twiflex Ltd. and Wichita Clutch, are well positioned to meet the power transmission challenges of the growing tidal turbine industry. Visitors will also be able to learn about other Altra products utilized on tidal turbines including shaft couplings and shaft locking devices, brake discs and hubs, torque limiting clutches and hydraulic power units.

**For more information:**

Altra Industrial Motion  
300 Granite Street, Suite 201  
Braintree, MA 02184  
Phone: (814) 480-5000  
[www.altracouplings.com](http://www.altracouplings.com)

**SKF**

RELEASES CONCENTRA ROLLER BEARINGS

New SKF ConCentra SYAF roller bearing units introduce ready-to-mount and highly reliable solutions for conveyors exposed to harsh operating conditions. An innovative and unique concentric mounting system properly and securely grips the circumference of a rotating shaft to virtually eliminate potential fretting corrosion, minimize risks of imbalance-initiated vibration, and promote optimized function and trouble-free performance, contributing to longer service life. They ideally suit operations ranging from mines, quarries, and cement plants to power plants and steel mills, among others.

These "shaft ready" one-piece assembled units integrate pre-lubricated SKF Explorer spherical roller bearings offering high load-carrying capacity, long life, and high-quality performance. A robust seal and flinger create a double-barrier to protect against ingress of contaminants, enhance grease retention, and minimize maintenance. A rugged



**It's your green world. We help moving it.**

- High quality and unique **GEARS** until 2 meter
- State of the art, **ECOLOGICAL** and **LEAN PROCESSES**
- Gear production completely **VERTICALLY** integrated, inclusive heat-treatment
- Innovative gear **DESIGN** knowhow
- **MICRO** corrected gears for:
  - gearlifetime over 25 years
  - higher efficiency
  - lower noise and vibration
- **WORLDWIDE** production plants: Romania, Belgium, Czech Republic, USA and China



[www.watteeuw.be](http://www.watteeuw.be)

# DIEQUA Corporation

The widest range of gearboxes, gearheads, gearmotors and reducers available from a single source...

### Gearmotors & Reducers

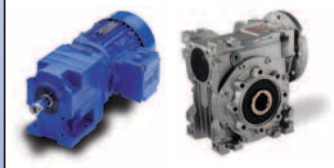

### Servo Gearheads

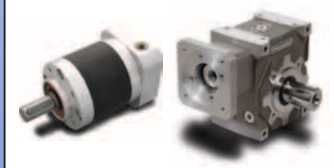

### Spiral Bevel Gearboxes

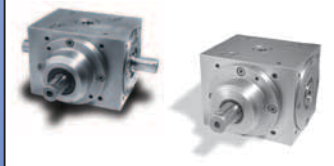

### Special Design Gearboxes



... and the experience to help you select the right one for your needs.

Let DieQua be an extension of your design team.

Contact us today!  
www.diequa.com  
630-980-1133

housing easily accepts heavy loads and reinforces durability in service.

The bearing units mount and dismount to the shaft quickly from the same side using only a torque wrench reducing axial space requirements. Once the bearing unit is correctly positioned on the shaft, angled set screws are tightened to axially displace the precision-engineered and matched stepped inner ring and sleeve, compressing the inner sleeve to grip the shaft evenly around the entire shaft circumference for a true concentric, tight fit. Up to 1.5 degrees of shaft misalignment can be accommodated without diminishing seal effectiveness. Shaft diameters range from 3<sup>7</sup>/<sub>16</sub> in. to 4<sup>15</sup>/<sub>16</sub> in. and the units can accept commercial grade or re-usable shafting without necessitating specially machined and costly ground or polished shafts. Housings are interchangeable

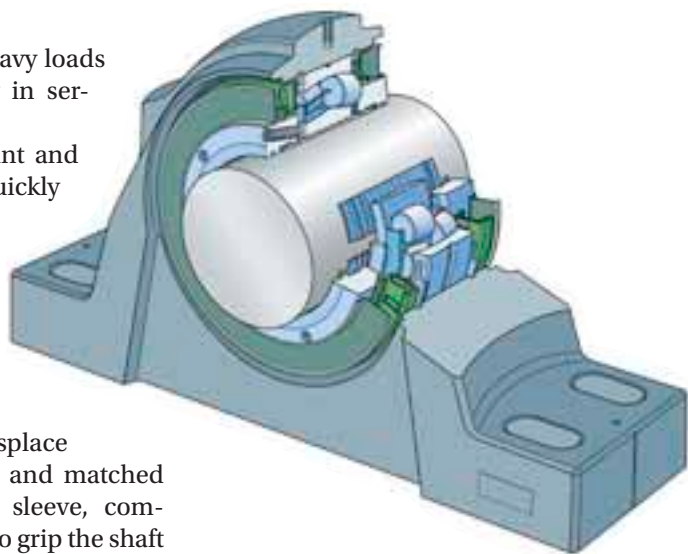

to industry bolt-pattern standards. Custom products can be developed.

### For more information:

SKF USA, Inc.  
890 Forty Foot Road  
Lansdale, PA 19446  
Phone: (267) 436-6000  
www.skfusa.com

## Romax Technology

### LAUNCHES GEARBOX AND DRIVELINE DESIGN SOFTWARE PACKAGE

Romax Technology, a gearbox, bearing and driveline engineering specialist, has launched a new design software package that will increase speed, quality, creativity and innovation when designing gearboxes and drivelines. Called *Concept*, the new product delivers on the Romax vision of streamlining the end-to-end planning to manufacture process with open, easy to use software solutions. It has been developed in close collaboration with engineers in the largest ground vehicle, wind energy and industrial equipment companies around the globe.

The result is a highly intuitive drag and drop design environment enabling rapid creation of concept models. It provides semi-automated sizing, definition and rating of gears, shafts and bearings, with advanced 3-D visualization capability allowing evaluation and manipula-

tion of key parameters. As a result it promotes creativity as new design ideas can be evaluated rapidly.

*Concept* also utilizes Romax's analytical capabilities to enable initial NVH assessments, as well as preliminary mechanical design assessments of alternative concepts.

It is applicable for any gear, shaft and bearing system application, from power tools to mining equipment and from complex automotive planetary auto-

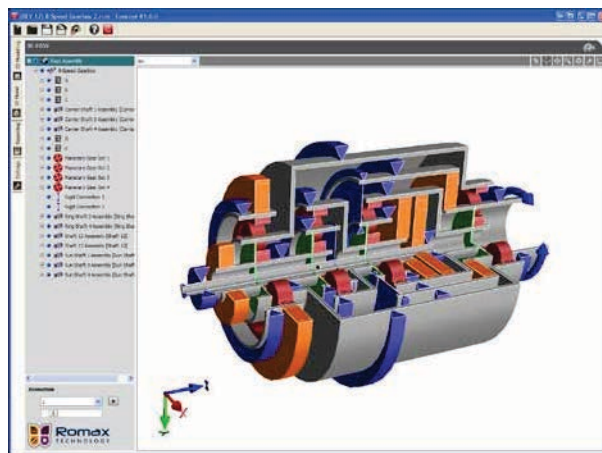

RomaxDesigner and RomaxWIND have evolved into a comprehensive whole-system simulation and analysis platform (courtesy of Romax).

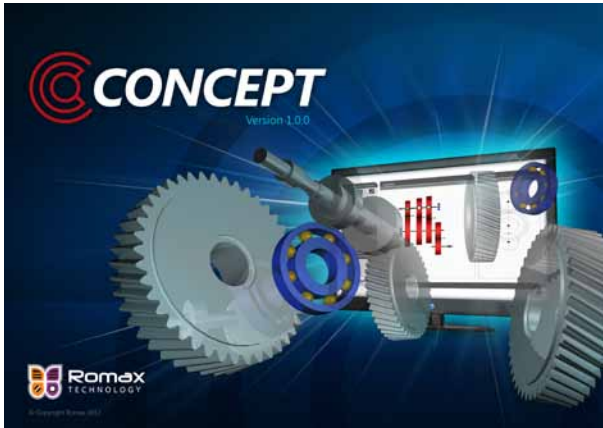

The Romax simulation and analysis software includes simulation design, gear optimization, system optimization, gearbox concept design, durability analysis, NVH analysis and tolerance and manufacturing variability assessment (courtesy of Romax).

matic transmissions to the largest wind turbine gearboxes. The new software not only enables creativity, effectiveness and efficiency, it also promotes a seamless workflow either as a stand-alone solution or used in conjunction with other CAD packages.

Its innovative easy-to-learn interface allows new users to become productive extremely quickly, which means graduate designers through to experienced gearbox and driveline design teams can use it. Romax Technology Product Manager, Dr. Jamie Pears, who is heading up the product launch, believes concept design is one of the most important aspects of the gearbox and driveline product development process.

“Early decisions can be crucial in shaping product performance, robustness and durability, as well as minimizing manufacturing and operating costs,” he said. “However, this stage of development can be expensive and time consuming too, meaning that many engineered products fail to reach their full potential. This next generation design package, which incorporates many of our advanced analytical algorithms, helps users to pull forward new concepts into robust and highly optimized designs capable of subsequent detailed development. It not only saves development time and cost but also improves the quality and robustness of the finished product.”

Also supporting Romax’s vision of streamlining end-to-end, planning-to-manufacture process is significant new capability in the company’s flagship

products for detailed design and analysis - *RomaxDesigner* and *RomaxWIND*. This enhanced capability for improved manufacturability of end-product includes a comprehensive suite of tools that enables the gear manufacturing process to be considered as part of the gear design and analysis activities. Romax an-

nounced *Concept* in October and will be shipping the software in December.

**For more information:**

Romax Technology  
Rutherford House  
Nottingham Science & Technology Park  
Nottingham  
NG7 2PZ  
Phone: +(44) (0) 115 951 8800  
[www.romaxtech.com](http://www.romaxtech.com)

**PROLONG BEARING LIFE**

SNUG FIT IN HOUSING WITH NO BINDING

All Springs Are Not Equal®

free samples  
free CAD models

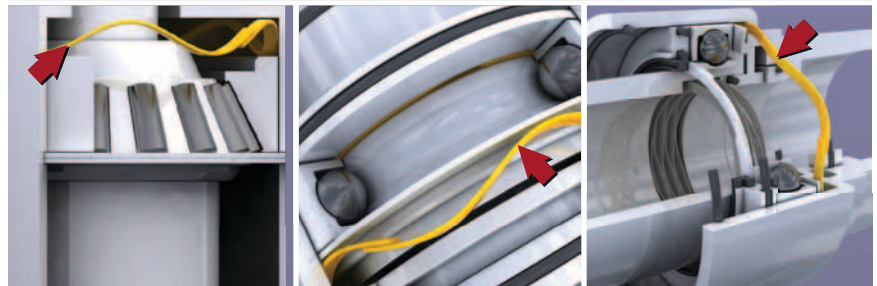

ELIMINATE **NOISY BEARINGS** ELIMINATE

**Smalley Springs Extend Bearing Life**

- Reduce vibration, noise and heat buildup
- Compensate for dimensional variation within assemblies
- Stock sizes 16 mm to 580 mm, matching popular bearing sizes
- Specials from .200" to 120" with No-Tooling-Charges™

[www.smalley.com](http://www.smalley.com)

**Smalley**®  
Steel Ring Company

[www.smalley.com/getcatalog](http://www.smalley.com/getcatalog) • [info@smalley.com](mailto:info@smalley.com)  
Lake Zurich, IL • 847.719.5900 • Fax: 847.719.5999

# AUTOMATE • 2013

January 21-24, 2013 | McCormick Place, Chicago, Illinois USA

## North America's Broadest Automation Solutions Event!

### Why Automate?

Automation can help you improve quality and productivity while reducing costs. Automate 2013 features automation solutions for every application and industry!

### How to Automate?

System integrators show how to automate applications such as material handling, assembly, inspection, quality control, packaging, material removal, welding and more!

### Who can help you Automate?

The world's leading automation suppliers and integrators will be at Automate 2013 demonstrating the latest robotic, machine vision, motion control, sensor, assembly and test/measurement solutions.



Register online for a **FREE** show badge  
[www.automate2013.com](http://www.automate2013.com)

Your Automate badge also gets you into the collocated ProMat™ Show

BROUGHT TO YOU BY





# Amacoil/Uhing

ANNOUNCE FLANGE DETECTION SYSTEM

Amacoil/Uhing has announced that their FA Flange Detection System has been reengineered for simpler operation and now utilizes laser sensor technology for expanded functionality. The new FA-II system is PLC-controlled and requires none of the tedious adjustments associated with the previous version. Additionally, whereas the original system worked only on spools having straight flanges, the new FA-II may be used with spools having either straight or tapered flanges. The FA-II system saves time by eliminating the need for an operator to adjust the reversal stops on the Uhing traverse. During spool changeovers, it is often the case that a new spool is not placed on the mandrel in the exact same position as the spool being replaced. Normally this means that a worker must readjust the end stops on the traverse to make sure the traverse reverses at the correct points. The FA-II eliminates this step saving time and enabling operators to manage more winding stations which helps boost production. Furthermore, winding accuracy is improved because

the laser sensor is a more accurate means of locating the spool flange edge than the human eye.

In its original version, the FA featured a two-pronged fork-shaped fixture mounted on the Uhing traverse. A steady beam of light between the prongs formed a light curtain which, when interrupted by the flange edge, triggered pneumatically controlled reversal of the traverse. Instead of a light beam, the FA-II system employs a laser sensor mounted to the traverse. The sensor continually references the distance from the spool core up to the highest point that wire or other material will be spooled. When the sensor detects the spool flange, the reading is not within the acceptable variance and a signal is sent to a pneumatic cylinder which reverses the traverse.

This arrangement also enables FA-II use with both straight and tapered flanges thereby expanding the system's



application. Because the distance from the sensor to the sloping surface of the tapered flange is less than the master reference point, reversal is not trig-

www.cincinnati-gearing.com gearsales@cst-c.com

## CINCINNATI GEARING SYSTEMS INC.

GEAR TOOTH HOBGING · GEAR TOOTH SHAPING · GEAR TOOTH GRINDING · SHAFT GRINDING · MILLING · TURNING



*Full Service Gear Manufacturing for the*

### Power Generation, Military, Marine, Mining, Oil & Gas and Transportation Industries.





*Quality Gears & Transmission Systems*

**P: 513.527.8600 F: 513.527.8635**



5757 Mariemont Ave. | Cincinnati, OH 45227

gered until the spool flange edge is detected.

To optimize the effectiveness of the FA-II Flange Detection System it is necessary that spool flanges are not bent or damaged. The laser sensor should be protected from particulate contaminants (dust, metal particles, wood chips, etc.). The FA-II system accommodates materials with round cross-sections and a diameter of 0.1 to 2.0 mm (.004 - .079 in.). Spool flange diameter may be up to 220 mm (8-43/64 in.) maximum. The system will handle spools with tapered flanges having an angle of up to 40 degrees. Operating temperature range is -10 to 40 degrees C (14 - 104 degrees F). Maximum operating air pressure is 6 bar (87 psi).

**For more information:**

Amacoil/Uhing  
2100 Bridgewater Road  
Aston, PA 19014  
Phone: (800) 252-2645  
[www.amacoil.com](http://www.amacoil.com)

## Cimcool

OFFERS HYBRID FLUID TECHNOLOGY FOR AUTOMOTIVE INDUSTRY

Cimcool Fluid Technology has announced the release of a new lubricant technology for machining and grinding of hard metals. These new Cimtech synthetic fluids feature synergistic lubricant blends that provide huge increases in productivity without the use of chlorine or other high levels of extreme pressure additives. Cimcool delivers significant cost reductions from the higher production rates these fluids can provide. More production and lower cost per part coupled with environmentally responsible fluids gives significant advantages to customers concerned with being competitive. With unique hybrid blends, including patented Milacron lubricants, only Cimcool can provide customers with these innovative fluids. Customers with heavy duty performance requirements looking to eliminate chlorine from their operations now have op-



tions never before available. "We have developed something that is completely new and unique to the industry," said Tina Hunter, automotive product manager. "These fluids work best when really pushed to the limit. The tougher

**ODG** DESIGN • MANUFACTURE • ASSEMBLE • TEST



# More than just gear cutting ...

Specializing in "Black Box" Transmission Design and Assembly

Ontario Drive & Gear Limited • New Hamburg, ON, Canada • 1.888.662.2840 • [www.ODG.com](http://www.ODG.com)

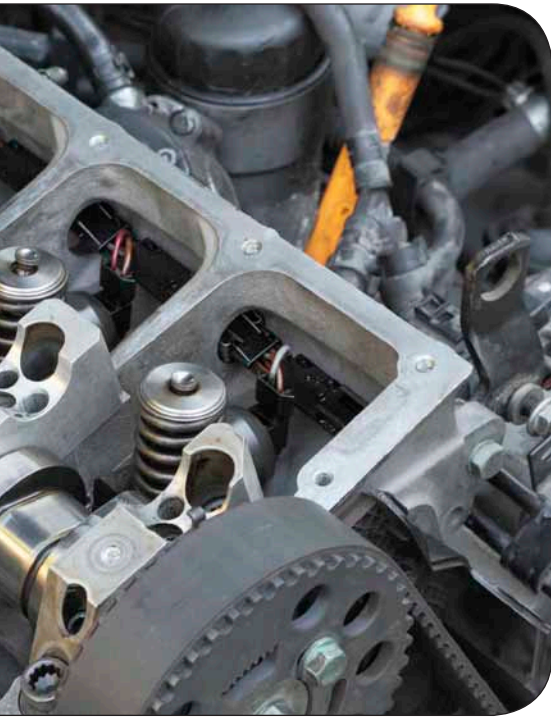

the operation, the better results we see. The performance of these fluids is significantly better. They have outperformed some popular heavy duty, sulfo-chlorinated oils by up to 300%. This is a huge jump in technology." Products include Cimtech 627 (a synthetic fluid used in heavy duty machining and grinding), Cimtech 609-E, (a water-based fluid used for hard metal valve grinding), Cimtech 610, (a unique Milacron Synthetic Lubricant blend for titanium and other hard metals), and Cimtech 612NF (a water-based synthetic for machining high-silicon aluminum alloys).

**For more information:**

Cimcool Fluid Technology  
 3000 Disney Street  
 Cincinnati, OH 45209  
 Phone: (888) 246-2665  
[www.cimcool.com](http://www.cimcool.com)

**YOUR WEAPON  
 AGAINST DOWNTIME.**

Scan the QR code for additional information about the Cost of Ownership of Diamond Chain Products

[www.diamondchain.com](http://www.diamondchain.com)  
 1-800-872-4246

**DIAMOND**  
 CHAIN COMPANY

DIAMOND INFINITY SAPPHIRE

©2012 The Diamond Chain Company. DCC-PTEM1012

Engineered to exacting customer specifications

Warehousing/consignment parts programs available

Forged from quality Timken™ steel

Software simulated to predict production issues

We inspect 100% of our parts, 100% of the time

Die blocks machined in house

Mag particle inspected

In North America, wherever you are, we are

**BETTER PARTS, START TO FINISH.**

**CLIFFORD-JACOBS  
 FORGING**

Clifford-Jacobs is a member of the IMT Forge Group of Companies. | 1-217-352-5172 | [www.clifford-jacobs.com](http://www.clifford-jacobs.com)

# Getting Creative

Beverage industry conveyor pours on advantages in distribution center

Motion Industries' two new Canadian distribution centers have no bottling lines, but that didn't stop the company from adopting a conveyor solution widely used in the bottling industry, where the system's low-friction components have proven to reduce operating costs. Designed by a Montreal-based OEM, the new flat-top conveyors use a System Plast chain and Browning gear drives from Power Transmission Solutions, a Division of Emerson Industrial Automation. The ultra-low-friction conveyor has delivered a range of advantages, including low noise, compactness and low energy use. According to Tom Sawyer, Motion's distribution center director, the conveyor is much quieter than a roller conveyor, vastly improving the work environment, and it has proven very reliable, conveying totes without the drift that can occur on a gravity roller conveyor. He emphasizes that the new conveyor demonstrates the plastic chain's advantages beyond a washdown environment.



Motion Industries Canada opened its two new distribution centers in August 2011, one in Edmonton and another in Montreal, replacing its single DC in Montreal and nearly quadrupling its size to 100,000 sq. ft. with the new facility. Both facilities have a conventional layout, with shipping and receiving on opposite ends of the building, and shelved inventory in the

center. The shelves branch off at right angles to the shipping conveyor, which runs down the center of the layout to a 90-degree turn and then to a 180-degree turn leading to five shipping lanes, each for a specific Canadian province.

"Our two DCs serve our 70 branches in Canada, and we also ship some product directly to customers," Sawyer explained. "We pick 2,000 to 2,400 lines per day for our branches, and each line may consist of many pieces of a specific product. Our warehouse management software consolidates orders from the branches so our pickers, using RF scanners, can efficiently pick in the same zone for multiple accounts. The product is regrouped in shipment, and a given branch may have several hundred lines going to it every day. We also pick about 200 orders per day for direct shipment to customers."



Motion's prior DC used two-level gravity and a powered roller conveyor. In the new DC, Motion looked for ways to reduce noise, eliminate maintenance and improve safety.

Motion teamed with a Québec OEM to design its DC conveyors. It was decided that the best product for the application was the flat-top System Plast conveyor, using XPG chain and Nolu S wear strips. This combination has a coefficient of friction of just 0.16, reducing energy consumption about 25 percent, compared to standard acetal chain and UHMW-PE wear strips. The XPG chain is also rated for 607 pounds, adequate for the 50-pound maximum tote weight handled at Motion's facilities.

"This type of belt proved ideal for a compact system layout," Sawyer explained. "For example, we did a 180-degree turn in a six-foot radius, measured on the outside of the conveyor. This is almost impossible with roller conveyor without transfer tables or pushers. Each of our systems includes a section of about 40 feet of ac-



cumulation conveyor with a cleverly designed surface that minimizes load and energy use. We use the accumulation section to spot check our totes for picking accuracy." Automatic sorting to the shipping lanes is planned for late 2012, using scanners and pushers, with manual sortation being used in the short term.

The new conveyor systems use six Browning 575-volt premium efficiency gear motors, with the gearboxes assembled on site at Motion's DC, which is home to the company's largest assembly shop in North America. End caps on the motors and bearings protect the rotating shafts. The conveyor

requires no compressed air in its accumulation zones, and reduces maintenance with elimination of belt-driven rollers.

"We've been surprised by the low noise level of this system, which enhances the workplace, and the conveyor has proven highly reliable," Sawyer added. "The totes are more secure on the chain than on rollers, much less likely to drift. The chain will actually realign totes slightly, and it easily transports them 175 feet to the first turn. We are quite pleased with the outcome and the results of the installation." **PTE**

**For more information:**

Emerson Industrial Automation  
8000 West Florissant Avenue  
St. Louis, MO 63136  
Phone: (314) 553-2000  
[www.EmersonIndustrial.com](http://www.EmersonIndustrial.com)



# When a Good Gear Drive System

By Brian P. Dahmer, Application Engineering Manager, SKF

Even when the critical components of industrial power transmission gear drive systems are properly designed, specified and manufactured consistent with application requirements, performance problems can develop over time and failure may follow.

Typical causes range from improper loading or installation to misalignment and poor maintenance practices, among other usual suspects. No component (gears, shafts, or bearings) will be immune from the potential for distress. However, when early warning signs of trouble are detected and corrective actions subsequently follow, catastrophic failure can be

avoided. In addition, a sustained preventive maintenance program—including visual monitoring—can contribute to overall efficient operation and longest possible service life of a gear drive system.

## Gearing up

Distress (or failure) of gears historically has been classified into sev-

A schematic-type drawing showing bearings/positions in a gearbox (all photos courtesy of SKF).

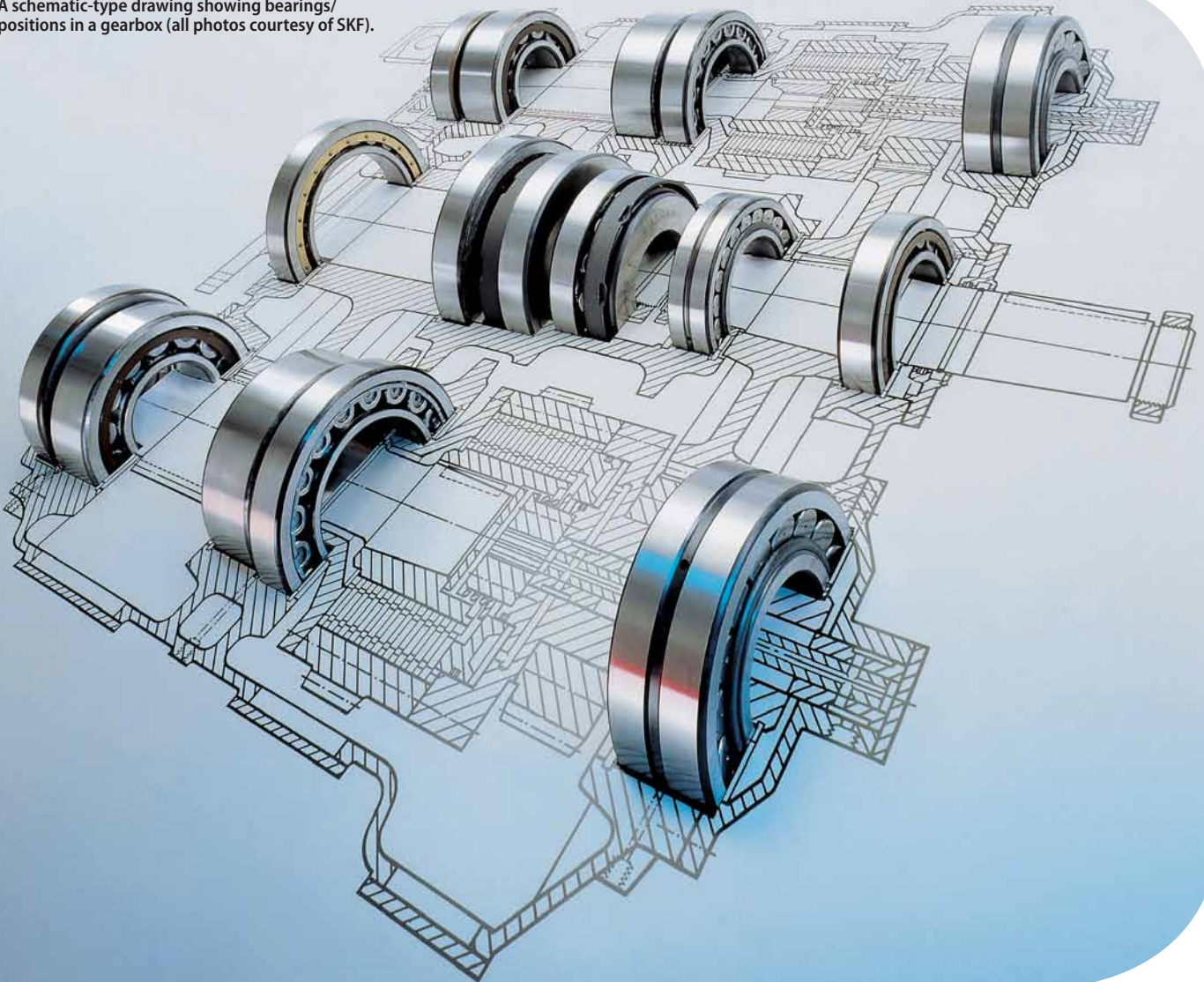

# Goes Bad

eral categories: *surface fatigue*, *wear*, and *breakage*. *Surface fatigue* occurs when the material of the gear fails as a result of repeated surface or sub-surface stresses beyond the endurance limit. The visual effects of surface fatigue will be evident in a variety of ways and, most obviously as “*pitting*” (either initial or destructive), which will often arise shortly after gear drive operation gets under way.

Both in through-hardened and surface-hardened gearing, *initial (or corrective) pitting* will be caused by uneven surfaces on the gear teeth placing high stress on local areas (the shape of a classical pit appears as an arrowhead pointing to the direction of oncoming contact). While initial pitting is considered normal for most through-hardened gears, it can be reduced by special tooth finishing or, in some cases, reducing loads and speeds during the running-in period.

In contrast, *destructive (or progressive) pitting* usually results from overload conditions, starting below the tooth pitch line and increasing in both size and number of pits until the surface is destroyed. Among recommended corrective measures: reducing the drive loading, improving lubricant type and viscosity, upgrading the gearing, and/or increasing the gear drive size.

*Abrasive wear* can occur when hard particles slide and roll under pressure across a gear’s tooth surface. Sources of these contaminants can include dirt in the housing, sand or scale from castings, metal wear particles from gear teeth or bearings, and/or ingress of particles into the housing during maintenance operations. Safeguards to help prevent this type of wear in-

clude proper lubrication in the right amount at the right time and effective seals to prevent the infiltration of contaminants. Flushing the gearbox with oil prior to assembly is recommended to remove as many machining particles as possible.

*Breakage* is perhaps the most dramatic type of gear failure, when stresses exceed the endurance strength of the tooth material, eventually developing fatigue cracks that will progress and cause the tooth to break away from the rim material. In fatigue fractures, system overloads would be suspect if the tooth contact pattern appears evenly across the entire face, while an alignment problem of the gearing would be suspect if the contact pattern is confined in the region of the fracture and at one end of the tooth.

In some instances a single overload may break out a tooth or several teeth, which can be prevented by protecting the gearing from high-impact or transient loadings. In other cases, a severely uneven distribution of load on gear teeth can occur from damage to associated parts. (For example, a bearing failure can cause the load to shift to one end of the teeth, resulting in breakage, or fractures can occur from a shaft that is severely bent or broken.) Visual inspection can help tell the story and suggest an appropriate resolution.

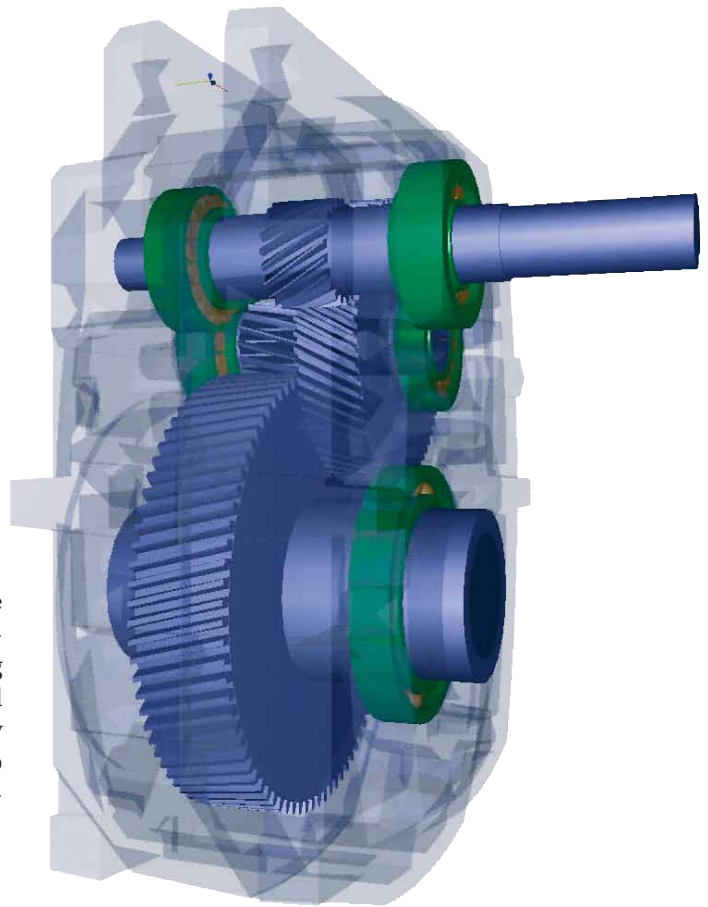

A semi-transparent view of a gearbox.

## Sizing up shafts

The strength and fits of shafting for gear elements will play vital roles in shaft operation, performance and longevity. Shafting must be rigid enough to prevent excessive deflection (which would result in abnormal load distribution on the gear teeth), and shafts must be strong enough to resist permanent yield from shock loads and the reverse bending fatigue loads. In turn, the fits between shafts and bearings—as well as between the shaft and the mounted gears—must be neither too loose nor too tight for fear of contributing to shaft failure. In general, confirm shaft strength, rigidity, fits and appropriate loads for the application at the outset to prevent serious operational problems down the road. These issues often are very difficult to change once the gearbox is completed and in service.

## Rolling to bearings

With few exceptions, rolling bearings will almost exclusively be specified to support the shafts and gear wheels of

industrial gearboxes—and for good reasons. Among them:

- Good location capabilities with minimum radial and axial play to enable optimum meshing;
- High specific load carrying capacity with low friction;
- Many bearing types can accept both radial and axial loads.
- Relative insensitivity to misalignment compared with plain or journal bearings;
- Unaffected by direction of load or rotation;
- Axially compact for use with short and stiff shafts.

In some gearbox designs, several different rolling bearing types will function in one gearbox. Regardless, at every turn demands on bearings during system operation potentially can lead to damage linked most often to the following modes warranting close monitoring and scrutiny:

- **Fatigue** defines a change in the bearing's material structure caused by repeated stresses in the contacts between rolling elements and raceways. *Subsurface fatigue* shows as micro-cracks at a certain depth under the surface and *surface initiated fatigue* is flaking that originates at the rolling surfaces.

- **Wear** is the progressive removal of material from the bearing's sliding or rolling contact surfaces during service. *Abrasive wear* usually can be linked to inadequate lubrication or ingress of contaminants and *adhesive wear* (or *smearing*) follows transfer of material from one surface to another.

The first visible indication of *abrasive wear* is usually a fine roughening or waviness of the bearing's surface. Fine cracks can then develop and spalling (or surface-initiated fatigue) will occur. If there is insufficient heat removal, the temperature may rise high enough to cause discoloration and softening of the hardened bearing steel.

From *adhesive wear* a bearing's surface assumes a "frosty" appearance and will feel smooth in one direction but distinctly rough in the other. Or, smearing damage may be apparent. One type of smearing develops between sliding surfaces, whereby minute pieces of one surface tear away and re-weld to either surface. (Areas subject to sliding friction, such as locating flanges and the ends of rollers in a roller bearing, are usually the first parts to be affected.) Another type of

smearing is called "skid-smearing," which can be detected as patches. This condition can result when rolling elements slide as they pass from the unloaded to the loaded zone and there is insufficient lubrication in the load zone.

**Fractures** occur when the ultimate tensile strength of bearing material is exceeded, causing a complete separation of a part of the bearing. *Forced fractures* result from a stress concentration in excess of the bearing material's tensile strength; *fatigue fractures* occur when the fatigue strength limit of the material is frequently exceeded; and *thermal cracking* (or *heat cracking*) will form cracks due to high frictional heating.

Definitive signs in "reading" the damage will suggest particular damage mode causes. Two of the primary suspects include *ineffective lubrication* and *ineffective sealing*. Here's what to look for when attempting to ascertain whether one of these causes is culpable:

Lubricant for a rolling bearing separates the rolling elements, cage, and raceways in both the rolling and sliding regions of contact. Without

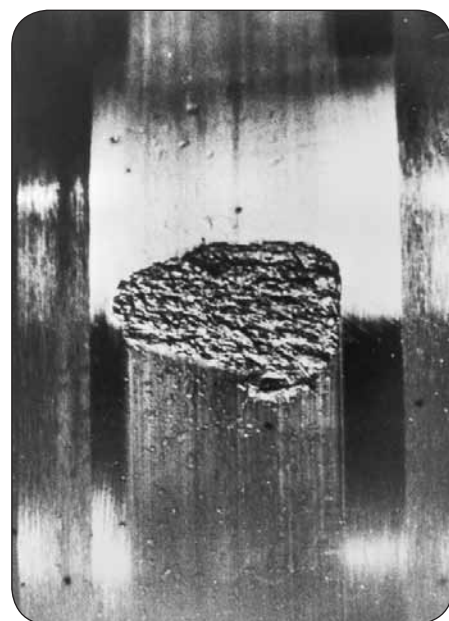
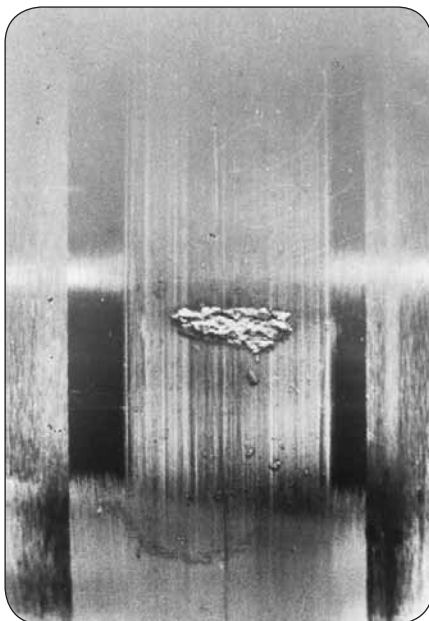

These three successive images show the fatigue progression on a bearing.



*effective lubrication*, metal-to-metal contact occurs between the rolling elements and the raceways, causing wear of the internal rolling surfaces. Most cases of “lubrication failure” will result either from insufficient or excessive lubricant viscosity, over-lubrication, contamination of the lubricant, or inadequate quantity of lubricant.

The effects of contaminants on bearings without *effective sealing systems* can also be devastating, even affecting lubricant performance. When debris is trapped between a bearing’s raceway and rollers, *plastic deformation* depressions, or particle denting, can develop. When spalling debris causes this condition, the effect is known as fragment denting. Each type of these small dents can be viewed as the potential origin of premature fatigue. In addition to abrasive matter, non-particle corrosive agents can invade. Water, acid and many cleaning agents deteriorate lubricants and lead to corrosion. Effective sealing will help keep contaminants out and keep lubricant intact.

### Monitoring for maintenance

Proper gearbox bearing maintenance begins by monitoring both the operating conditions and the bearings for early identification of trouble. Among the important parameters to monitor:

- **Lubrication.** Lubricant supply in oil bath systems can be checked using simple technology (such as a dipstick). For circulating oil lubrication, however, complex systems will be required to check oil pressure, flow rate, and temperature at each lubrication point. Often, an alarm system can add timely value. Oil samples can be taken and analyzed for contamination levels and oil deterioration.
- **Load.** The power consumption of a gearbox drive is sometimes used as a measure of the load, but will be

unsuitable for monitoring bearing loads. Better information will be obtained by measuring torque at the root of gear teeth.

- **Temperature.** Measuring bearing temperature usually will apply to bearings operating at high speeds—and then only as an indication of trends—with temperature preferably measured directly on the bearing rings. In addition, temperature measurements of bearings, gearbox and oil will help determine the operating viscosity of the oil, which then can open a window into operating conditions.
- **Wear.** A clear indication that particles of bearing steel are among perceived wear particles will suggest that a bearing has already become damaged. If so, the gearbox should be inspected to determine the source of the wear and remedial action should be implemented to prevent further damage. (Wear particle analysis also enables gear wear and seal efficiency to be monitored.)
- **Vibration.** Depending on extent, the presence of vibration, especially in excess, may indicate system trouble. Suitable procedures to monitor vibration include comparative measurements on similar gearboxes under the same

operating conditions (allowing differences to be observed) or trend measurements on one gearbox at given intervals to uncover differences.

Inspection and analysis of all critical components in a gearbox drive system can offer practical insights into whether damage and failure are on the horizon. Whenever possible, evidence from a failed component should be collected and interpreted to establish what went wrong and why—with the ultimate goal to avoid unproductive and costly recurrences and increase system uptime. **PTE**

#### For more information:

Brian P. Dahmer  
SKF USA Inc.  
890 Forty Foot Road  
Lansdale, PA 19446  
Phone: 267-436-6517  
Fax: 267-436-6029  
brian.p.dahmer@skf.com  
www.skfusa.com



The TKSA 20 laser shaft alignment tool from SKF.

# Have a Pump, Motor, Generator, Turbine, Compressor or Gearbox?

## *There's a Bearing for That!*

Mick Corrie, business team manager, Waukesha Bearings

*Waukesha Bearings is known internationally for its capabilities, technology, size and application experience in the rotating (turbo) equipment industry. Following is a brief selection guide intended to assist engineers, specifiers, integrators and others in choosing the right bearing—and bearing technology—for the application.* (Ed.'s note: the predominant applications for the following products are: pumps; motors; compressors; turbines; generators; and gearboxes.)

**Tilting-pad thrust bearings.** Tilting-pad thrust bearings (Fig. 1) are available with a variety of design features, including directed lubrication, specially engineered pivot types and offsets, pad backing material and several different styles of thrust retainers—all designed to optimize performance and meet unique requirements in turbo-machinery. Custom solutions are also available that offer reduced power losses, oil flow and pad temperatures,

and address industry-wide issues such as axial vibration.

**Tilting-pad journal bearings.** Tilting-pad journal bearings (Fig. 2) help ensure high performance and optimal compatibility with a variety of turbo-machinery. Available options include hydrostatic jacking, combined

combination with a variety of custom-engineered mating surfaces. Polymer-lined bearings are suitable for both oil and clean product lubrication. In applications where the bearing material must be chemically resistant to the clean fluid and able to support thin films, solid polymer bearings provide a high load

**Ceramic bearings can be used with virtually any liquid lubricant, making them the ideal solution for many challenging field conditions; liquefied gas, hydrocarbon condensates and seawater are commonly used.**

single- or double-acting thrust capability, spherical seats and electrical insulation. To achieve varying degrees of alignment capability, a number of pad pivot types and pad geometries are available.

**Polymer-lined and solid-polymer bearings.** Polymer-lined and solid-polymer bearings (Fig. 3) feature bearing-grade polymers used in com-

capacity and inert solution. These specially engineered polymers are used on both journal and thrust bearings and provide exceptional temperature capabilities (beyond 250°C or 482°F), thin film operation, high fatigue strength, insulating properties and the ability to withstand continuous high load.

**Horizontal bearing assemblies.** Horizontal bearing assemblies (Fig. 4)

Figure 1 Tilting-pad thrust bearings.

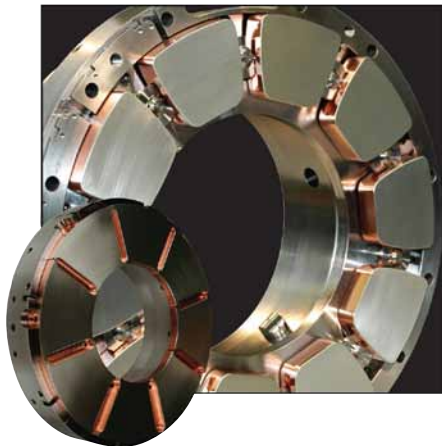

Figure 2 Tilting-pad journal bearings.



Figure 3 Polymer-lined and solid-polymer bearings.



include highly customized journal—or combined journal and thrust—units designed to interface with an external pressurized oil system. Proven arrangements can be fitted with an external casing or engineered to interface with the customer’s own housing. The extent of supply, including hydraulic jacking systems, can be varied to suit application requirements and customer specifications.

**Active-magnetic bearings.** Active-magnetic bearing systems (Fig. 5) offer a proven “oil-free” solution for the unique challenges associated with large turbo-machinery. Energy-efficient and requiring less maintenance by eliminating supporting oil systems, active-magnetic bearings may be implemented to be emission-free and to provide increased machine availability and uptime. Bearing systems are custom-designed with controllable rotor-dynamics—an auxiliary bearing technology—remote monitoring and control, and the security of an advanced controller for challenging turbo-machinery applications.

**Fixed-profile bearings.** Fixed-profile bearings (Fig. 6) are optimized to meet the changing demands of various applications operating at a wide range of speeds. Specially engineered designs of multi-lobe bore versions are ideal for high-speed applications. Design options include thrust load capacity on the end faces, hydrostatic jacking for use at start-up and run-down, and machining for instrumentation. In addition to standard steel, other material linings are may be used to meet differing application requirements.

Figure 4 Horizontal bearing assemblies.



Figure 5 Active-magnetic bearings.

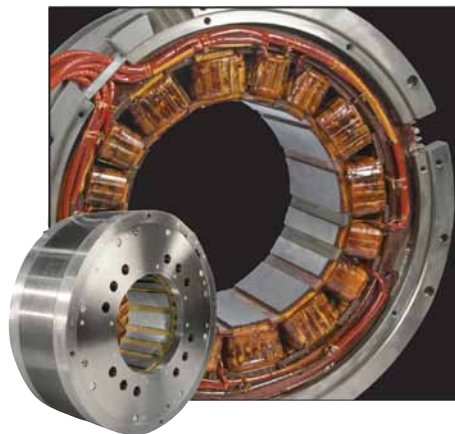

Figure 6 Fixed-profile bearings.



McINNES  
ROLLED RINGS

TWICE AS BIG,  
JUST AS FAST.

1-2 WEEK  
DELIVERIES  
with materials in stock.

CARBON,  
ALLOY &  
STAINLESS  
STEEL RINGS  
4-144" OD.



mcinnesrolledrings.com

**Ceramic bearings.** Ceramic bearings (Fig. 7) can be used with virtually any liquid lubricant, making them the ideal solution for many challenging field conditions; liquefied gas, hydrocarbon condensates and seawater are commonly used. Pads and mating sleeves, or collars, are matched to suit the specific application and lubricant—even if it contains abrasives. Ceramic bearings are primarily used in pumps to provide more compact, lower-cost machines, thus saving weight, space, sealing and the expense involved with an oil lubrication system.

**Vertical bearing assemblies.** Vertical bearing assemblies (Fig. 8) include a variety of design options, including electrical insulation, hydrostatic jacking and instrumentation. Proven designs range from large, self-contained combined-journal and thrust units for primary coolant pumps and motors used in nuclear power stations, to small, self-contained air-cooled units for LNG pumps. Air cooling has been increasingly used as it avoids the complications associated with water-filled coils and allows operation on remote sites where water may not be available. **PTE**

Figure 7 Ceramic bearings.



Figure 8 Vertical bearing assemblies.



### Product/Application Key

**Pumps.** Pumps are built in a wide variety of sizes and types—from nuclear primary to electric submersible. As a result, they may employ magnetic bearings. Pumps also use polymer-lined and solid-polymer bearings with oil and water lubrication, as well as process-lubricated ceramic bearings.

**Motors.** Motors are also good candidates for active magnetic bearings, due in part to the fact that pumps and motors are often matched together. Smaller motors—particularly in vertical submersible motor/pump sets—use polymer or ceramic bearings for load-carrying capability and long life.

**Generators.** Depending on size and orientation, bearing products are used in generators as internal bearings or complete assemblies with a housing. With steady weight-loading and modest synchronous speeds, generators tend to use the conventional material combination of white metal and steel backing. Hydrostatic jacking for start-up and run-down is common on larger machines.

**Turbines.** Depending on size, gas and steam, turbines normally use tilting-pad journal and thrust bearings—sometimes in combined assemblies. Directed lubrication is

usually employed to minimize power losses and oil flows, and to reduce pad surface temperatures. Gas turbine thrust bearings are high-speed and high-load, often requiring the use of Cu/Cr backing material.

**Compressors.** High-speed compressors can be very demanding of journal bearings due to their dynamic properties; four or five tilting-pad journal bearings are commonly used. Thrust bearings are normally the tilting-pad type, with directed lubrication to minimize power losses, and they often utilize Cu/Cr backing material to reduce pad surface temperatures. Compressors often use active magnetic bearings as well.

**Gearboxes.** Low-speed shafts for gearboxes normally use fixed-profile journal bearings—often with simple cylindrical bores. And high-speed shafts use either multi-lobe, fixed-profile or, increasingly, tilting-pad journal bearings. Very high-speed applications may require special material combinations and directed lubrication to reduce pad surface temperatures and improve efficiency.

### For more information

Waukesha Bearings  
W231 N2811 Roundy Circle East  
Suite 200  
Pewaukee, WI 53072  
Phone: (262) 506-3000  
Fax (262) 506-3001  
[www.waukeshabearings.com](http://www.waukeshabearings.com)

# Hungry for More?



Everything you need if you buy gears, bearings, motors, couplings and clutches.

## Power Transmission Engineering

- Product and Industry News Updated Daily
- Directory of Mechanical Power Transmission Suppliers
- Exclusive online content in our e-mail newsletters
- Back Issues and Article Archive
- Calendar of Upcoming Events for power transmission professionals

[www.powertransmission.com](http://www.powertransmission.com)

# Selecting and Sizing Ball Screw Drives

Jeff G. Johnson, Product Engineer, Thomson Industries, Inc.

## Introduction

The ball screw drive is an assembly that converts rotary motion to linear motion and vice versa. The ball screw drive consists of a ball screw and a ball nut with recirculating ball bearings (Fig. 1). The connection between the screw and the nut is made by ball bearings that roll in the matching forms in the screw and ball nut. The forces transmitted are distributed over a large number of ball bearings, giving a comparatively low relative load per ball. With rolling elements the ball screw drive has a very low friction coefficient. Ball screw drives typically provide mechanical efficiency of greater than 90%, so their higher initial cost is often offset by reduced power requirements. The features of ball screws in relation to other linear actuation devices are summarized in Figure 2 and the important ball screw specifications are summarized in Figure 3.

## Optional Inputs

Figure 4 provides an overview of the parameters used in the ball screw selection and sizing process. The optional inputs make it possible for the designer to specify basic preferences for a specific type of ball screw early in the selection process. It's important to note that specifying optional inputs may unnecessarily restrict component selection. As an example, if you select metric product series you eliminate about half of the possible ball screw alternatives even though it's possible that an inch series ball screw might work just as well in the application.

## System Basic Parameters

The system basic parameters identify the basic geometric requirements of the application. The system orientation is important because with a horizontal orientation the load is equal to the payload weight times the frictional coefficient

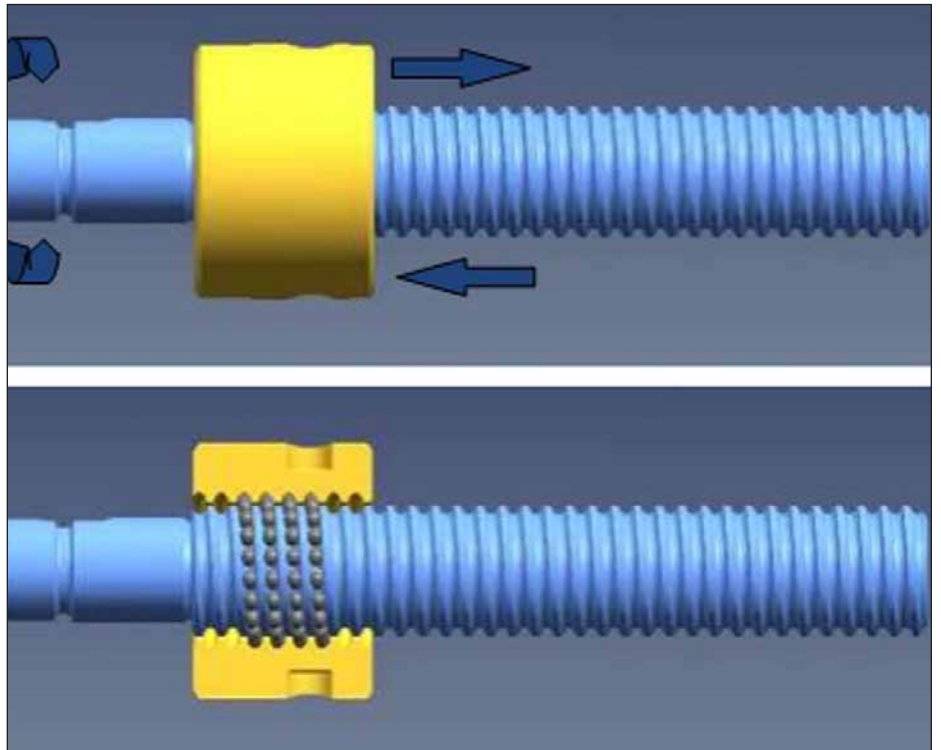

Figure 1 Ball screw drive is a popular linear actuator.

while with a vertical orientation the load is equal to the weight. The positional requirements determine which grade of ball screw is suitable for the application. Figure 5 shows the positional accuracy capabilities of various types of ball screws:

Backlash is the linear independent motion between the ball screw and the ball nut and can be controlled by preloading the nut. With skip-lead preload, the lead is offset within the ball nut to provide a precise preload. This type of preload is typically used where both repeatability and high stiffness are needed. Double-nut adjustable preload involves the use of a compression spring to axially load two ball nuts against each other. It is typically used for positioning applications where repeatability is critical. Where no preload is used, axial play is present between the screw and nut, typically 0.002 inch to 0.008

inch depending on the size. No preload is typically used for transport or vertical applications.

The type of drive system is another basic screw parameter. In a screw-driven system, the nut is fixed and the screw is driven while in a nut-driven system the screw is fixed and the nut is driven. Mounting of ball screw ends is described as either supported or fixed. A supported end holds the ball screw at one focal point and does not resist bending moments. A fixed end resists bending moment loads because it is typically based on two bearings spaced sufficiently so the ball screw remains perpendicular to the planes of the rotary bearings. The fixed offers great column strength and higher critical speed. On the other hand, a supported end is more compact and has a lower cost. A supported end is generally easier to align and install than a fixed end so

installation costs are typically lower. A ball screw can be fixed at one end and free at the other; supported at both ends; fixed at one end and supported at the other; fixed at both ends.

### Application Parameters

Application parameters begin with defining the direction and magnitude of the load. The ball screw works best with axial load only. The ability of a ball screw to avoid buckling under a compressive load is called its column strength. The screw must carry an axial load that is equal and opposite to the load generated on the ball nut by the motor's torque. In general, column strength is the controlling design parameter because for long columns it is much lower than the material's strength in compression. Because the length to diameter ratio is important in column buckling, it follows that the compression load strength of a ball screw is dependent upon its length. A ball screw with both ends fixed can be one and a half times longer than a ball screw with both ends merely supported and two and half times as long as a ball screw with a free end while supporting the same amount of load without buckling.

The limiting speed of a ball screw is usually its tendency to vibrate based on its natural frequency. The critical speed is the rotary speed that sets up harmonic vibrations in the ball screw and is a direct consequence of the characteristic frequency of vibration of the ball screw. For example, a 100 inch long 1 inch root diameter ball screw with both ends fixed has a natural frequency of about 18 Hz. With both ends supported rather than fixed the natural frequency of the same ball screw is reduced to about 8 Hz. If the rotational frequency of the screw matches the screw's natural frequency, slight imbalances in the screw can resonate. Excessive bending and bowing then keep the screw from working properly.

Some of the types of guides than can be used include linear rail and profile rail. The life should be defined based on the operational profile—how many hours per day, days per week and weeks per year the ball screw will be run—and the overall life requirement for the ball screw. For more complex applications,

Hand Actuation	Low cost, slow speed
Acme Screw	Low cost, moderate speeds, multiple positioning
Air cylinder	Single position, moderate loads, can be costly if you don't already have air, can drift
Ball Screw -- Precision Plus or Precision	High speeds, repeatable, accurate, moderate cost, longer strokes with rotating nut
Belt Drive	High speed, multiple positioning repeatable, moderate accuracy and load
Cable & Chain	Low cost, light duty applications, not very robust
Hydraulic Cylinder	Very high loads, single position
Linear Motor	Highest speeds, relatively lights loads, highest accuracy
Rack & Pinion	Moderate speed, long strokes, and moderate to heavy loads
Roller Screw	High loads, moderate speed

Figure 2 Summary of linear actuation devices.

you also have the option to build a complete motion profile. Each segment of the motion profile requires entry of the speed at the beginning of the segment, the speed at the end of the segment, the segment time and the torque during the segment.

### Selection and Sizing Example

To demonstrate how to select and size ball screws, we'll use a three-axis welding gantry application as an example (Fig 6). The ball screw runs the entire length of the x axis and is supported on either end by bearing supports. For simplicity's sake we will define the nut mounting as flange, material as alloy steel, thread direction as right hand and product series as Metric. The system orientation in this application is horizontal with a screw driven design. The length of the x axis is 6 meters. We will use fixed ends with a thermally stable flange mount. High levels of accuracy are not critical in this application, so we will select a precision ball screw with no preload. Wipers are needed because this is a dirty environment, but alloy steel is acceptable and no special finish is needed.

A load of 2,668.9 Newtons (600 lbs) is applied by a carriage riding on profile rails. The travel length is 4.5 m (177.165 in) and the unsupported length is 5.818

Important Ball Screw Specifications
<b>Static Load Rating</b> – Maximum non-operating load capacity above which brinelling of the ball track occurs. NEVER exceed the Static Load Rating
<b>Dynamic Load Rating</b> – Maximum load that an assembly can maintain for 1.0 million inches of travel (Inch Series) or 1.0 million revolutions (Metric Series). Exceeding the Dynamic Load Rating is not recommended
<b>Lead Error</b> – Amount of positional error per foot (Inch Series) or per 300mm (Metric Series). Measure of accuracy.
<b>Backlash</b> – Axial free motion between ball nut and ball screw. Measure of stiffness and repeatability.
<b>End Fixity</b> – End support configuration that affects speed and column loading

Figure 3 Ball screw specifications.

m (229.055 in). The required speed is 0.1 meters per second (3.927 in/sec) and an acceleration and deceleration of 2.5 m/s<sup>2</sup> (98.4 in/s<sup>2</sup>) is needed. The duty cycle is 8 hours per day, 5 days per week and 50 weeks per year with an average of 10 cycles per hour. The life requirement is 20 years for the ball screw and 5 years for components. An additional requirement is that a stepper motor be used due to a preference of the electrical engineering department.

Next, we will select the linear bearings for the x axis. The primary requirements of this application are high load capacity and high stiffness. The application involves a relatively long length of 5.5 meters (18 feet); however the

availability of 6 meter length screws eliminates the need for butt joining. Low maintenance is another important requirement of this application. The result was the selection of Thomson 500 Series ball profile rail linear guides.

With this selection made, we can calculate the load on the ball screws.

$$F = N \times \mu_r$$

Where:

$\mu_r$  is the frictional coefficient, which is 0.005 for this particular linear guide

$$F = 2,698 \text{ N} \times 0.005 = 13.3 \text{ N} (3.0 \text{ lbs})$$

$$F = ma = 2,668.9 \text{ N} / 9.81 \text{ m/s}^2 \times 2.5 \text{ m/s}^2 = 680.1 \text{ N} (153 \text{ lbs})$$

$$F_{eq} = - 303.8 \text{ N} (68.3 \text{ lbs})$$

Based on this loading, we will select the NEFF KGF-D ball nut as the starting point. This ball nut has an integral flange, integral wiper and a DIN 69051 mounting and the ball screw has an accuracy of  $\pm 50 \mu\text{m} / 300 \text{ mm}$  accuracy.

Next we will look at the motor requirement. Because of our requirement to use a stepper drive we want to keep the rpm fairly low. The rpm can be determined by this formula:

$$\text{RPM} = \text{Travel rate (mm/min)} / \text{Lead (mm)}$$

Our options are:

- 100 mm/s \*60 / 1,200 rpm = 5 mm
- 100 mm/s \*60 / 600 rpm = 10 mm
- 100 mm/s \*60 / 300 rpm = 20 mm

Since we want to keep the RPM down, we will select a 20mm lead ball nut which meets our cycle time requirement while keeping the RPM down to levels that can be met by a stepper motor.

We can calculate the torque requirement using this formula:

$$T_d [N \bullet M] = 1.77 \times 10^{-4} \times F_{eq} \times P$$

Where:

- T = Torque (Nm)
- F = Load (N)
- P = Lead (mm)

The resulting torque is...

$$T_d = 2.15 \text{ Nm} (304.5 \text{ oz-in})$$

The maximum torque during acceleration is:

$$T_d = 4.82 \text{ Nm} (682.6 \text{ oz-in})$$

A NEMA 42 stepper motor was selected based on the application and torque data.

Next we will look at the critical screw speed which can be found using the following equation:

$$n_c (\text{rpm}) = C_s \times 1.2 \times 10^8 \times d_r / I^2$$

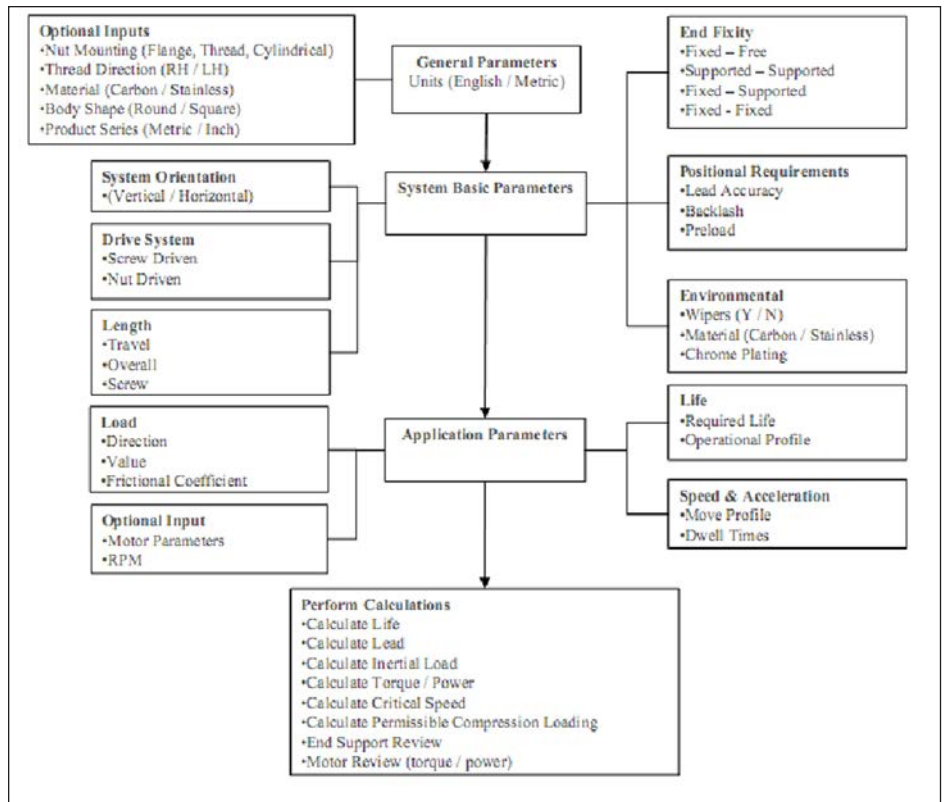

Figure 4 Ball screw selection and sizing parameters.

Ball screw type	Accuracy
Precision inch	$\pm 0.004 \text{ in/ft}$
Precision plus inch	$\pm 0.0005 \text{ in/ft}$
Precision metric - T7 Accuracy Class	$\pm 50 \mu\text{m}/300\text{m}$
Precision metric - P5 Accuracy Class	$\pm 23 \mu\text{m}/300\text{m}$
Precision plus metric - P3 Accuracy Class	$\pm 12 \mu\text{m}/300\text{m}$

Figure 5 Positional accuracy capabilities of various types of ball screws.

Where:

$C_s$  is a constant based on the end fixity factor:

$d_r$  = root diameter (mm)

I = unsupported length (mm)

$$63 \text{ mm} \times 20 \text{ mm}$$

$$d_r = 56.9 \text{ mm}$$

$$I = 5,818 \text{ mm}$$

$$n_c = 449.8 \text{ rpm}$$

$$n_s = n_c \times S (\text{safety factor of } 0.8)$$

$$n_s = 359.9 \text{ rpm}$$

$$300 < 359.9 - \text{Pass!}$$

In this case we shall consider three different ball screw sizes for critical speed in this application:

$$40 \text{ mm} \times 20 \text{ mm}$$

$$d_r = 35.9 \text{ mm}$$

$$I = 5,818 \text{ mm}$$

$$n_c = 283.8 \text{ rpm}$$

$$n_s = n_c \times S (\text{safety factor of } 0.8)$$

$$n_s = 227.1 \text{ rpm}$$

$$300 > 227.1 - \text{Fail!}$$

$$50 \text{ mm} \times 20 \text{ mm}$$

$$d_r = 44.1 \text{ mm}$$

$$I = 5,818 \text{ mm}$$

$$n_c = 348.6 \text{ rpm}$$

$$n_s = n_c \times S (\text{safety factor of } 0.8)$$

$$n_s = 278.9 \text{ rpm}$$

$$300 > 278.9 - \text{Fail!}$$

Now we will check critical nut speed which can be determined by the following formula:

$$DN = d_o \times n$$

Where:

$$DN = 140,000$$

$$d_o = \text{nominal diameter (mm)}$$

$$n = \text{rpm}$$

Evaluating the critical nut speed of the ball screw that meets our critical ball speed requirement:

$$DN = 63 \times 300 = 18,900$$

$$18,900 < 140,000 - \text{Pass!}$$



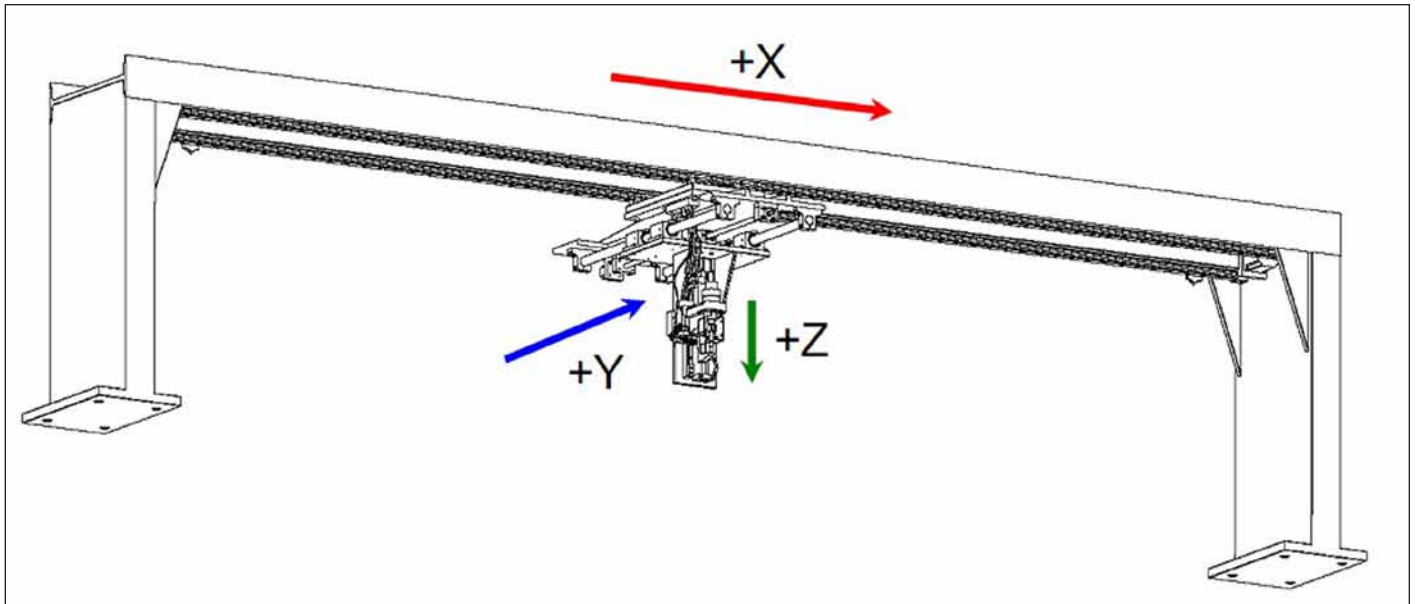

Figure 6 Welding gantry application.

Next we will look at compression loading in this application, which is determined by the following formula.

$$F_c [N] = C_s \times 9,687 \times 10^4 \times d_r^4 / l^2$$

Where:

$F_c$  = Critical buckling force (N)

$C_s$  = End fixity factor based on following table:

$d_r$  = root diameter (mm)

$l$  = unsupported length (mm)

Inputs:

$$D_r = 56.9$$

$$l = 5,818 \text{ mm}$$

$$C_s = 4.00$$

Outputs

$$F_c = 119,991.6 \text{ N}$$

$$F_s = F_c \times S \text{ (Safety factor of 0.8)}$$

$$F_s = 95,993 \text{ N}$$

Verification

$$680.1 \text{ N} < 95,993.3 \text{ N} - \text{Pass!}$$

The last thing to check is the life expectancy requirement. Life is typically rated at  $L_{10}$ , which represents the time after which 90 percent of ball screws will still perform.

$$L_{10} \text{ (revolutions)} = (C_{am} / F_{eq})^3 \times 10^6$$

In this application life expectancy is 1,035,752.6 years. The reason life is so high is that we selected the ball screw based on critical speed rather than life.

Finally we will check the life expectancy of the bearing supports. A typical fixed bearing support is the WBK Series. The life expectancy of a bearing support can be determined using this formula.

$$L_{10} \text{ (hours)} = (C_{am} / P_r)^3 \times (1 \times 10^6 / 60 \times n)$$

$$P_r = (0.35 \times F_r) + (0.57 \times F_a)$$

$$C_{am} = 51.5 \text{ kN (11,577.7 lbs)}$$

$$F_a = 68.3 \text{ lbs} / 2 = 34.15 \text{ lbs}$$

$$F_r = 0.0 \text{ lbs}$$

$$P_r = 19.47 \text{ lbs}$$

$$L_{10} = 22.1 \text{ years}$$

$$22.1 > 5 - \text{Pass!}$$

The ball screws driving the y and z axes can be selected and sized using similar methods.

## Conclusion

As this example shows, the selection of the correct ball screw assembly for a specific application is an iterative process that determines the smallest envelope and most cost-effective solution. The design load, linear velocity and positional accuracy are used to calculate the diameter, lead and load capacity of the ball screw assembly. Individual ball screw components are then selected based on life, dimensional constraints, mounting configuration and environmental conditions. **PTE**

### For more information:

Thomson Industries, Inc.

Wood Dale, IL

Phone: (540) 633-3549

Thomson@thomsonlinear.com

www.thomsonlinear.com

**Jeff Johnson**, product engineer for Industrial Screws, has been with Thomson for nearly six years. He is responsible for new product development and application support for the N.A. market, and specializes in ball screws



and lead screws. He has been involved with system and component design of linear motion products for over 20 years and holds numerous patents and technical citations. Johnson earned a Bachelor of Science in Aerospace Engineering and studied Mechanical Engineering at the University of Arizona. Johnson also earned his MBA by graduating Beta Sigma Gamma from the WP Carey School of Business at the Arizona State University with an emphasis in international marketing. He also is a registered professional engineer in mechanical engineering in California.

# High-Frequency, GaN Diode-Free Motor Drive Inverter with Pure Sine Wave Output

Y-F. Wu, D. Kebort, J. Guerrero, S. Yea, J. Honea, K. Shirabe and J. Kang

This article presents the first kW-Class, 3-phase GaN-based inverter. Hard-switched at 100-kHz PWM, its heart is a 6-in-1 power module with 600-V GaN power HEMTs, achieving a new efficiency of 98.5%, a more than 2% improvement.

## Introduction

Silicon-based power switching devices have improved dramatically since their inception decades ago. An impressive example: Si super-junction MOSFETs, such as CoolMOS FETs, broke the theoretical Si limit in the tradeoff between blocking voltage and resistance (Ref. 1).

However, the large amount of minority charge in the body diode results in large reverse recovery losses in hard-switched bridge circuits—typical for motor-drive inverters. Thus insulated-gate-bipolar-transistors (IGBTs) are preferred in applications also requiring additional reverse-connected diodes for freewheeling current. With the relatively low-frequency bandwidth, IGBT-based inverters typically operate at 4–20 kHz and directly apply pulse-width-modulation (PWM) power to the motor with the intention of utilizing the motor windings as energy storage inductances. The resultant voltage transients induce high stresses between motor windings and cause current spikes through motor bearings, leading to issues such as insulation breakdown and excessive bearing wear (Refs. 2–3). This paper demonstrates the use of wide-band-gap semiconductor GaN for hard-switched motor drive applications. The functionalities and frequency capabilities of the GaN high-electron mobility transistor (HEMT) eliminate the need for freewheeling diodes and allow a much higher PWM frequency, in turn enabling compact filters and resultant, spike-free, pure sine wave power output.

## Devices and Module

The unit cell device used in this study is a GaN hybrid HEMT (Transphorm, Inc.). It incorporates a normally “off” low-voltage Si device at the input and a normally “on” high-voltage GaN HEMT at the output in cascode form (Fig. 1). The combined device is normally “off” with a gate threshold of + 2.1 V—typical at 1 mA drain current—and a drain leakage of 10  $\mu$ A—typical at  $V_{gs}=0$  V and  $V_d=600$  V. The “on” resistance is

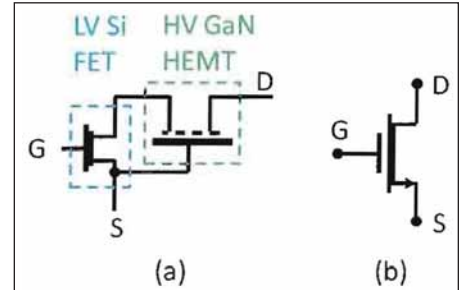

Figure 1 Hybrid HEMT with low-voltage, normally “off” Si FET and high-voltage, normally “on” GaN HEMT (a) to achieve a combined, normally “off” device (b).

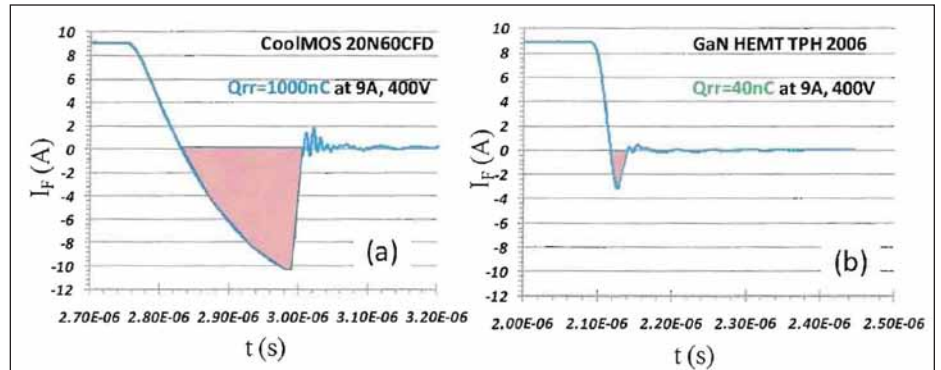

Figure 2 Reverse-recovery charge test result for (a) fast-recovery CoolMOS and Transphorm GaN HEMT, with reduction of  $Q_{rr}$  by 25x by GaN. Note current transient is 450 A/ $\mu$ s for GaN HEMT and only 100 A/ $\mu$ s for CoolMOS, due to excessive ringing at higher  $dt/dt$  values.

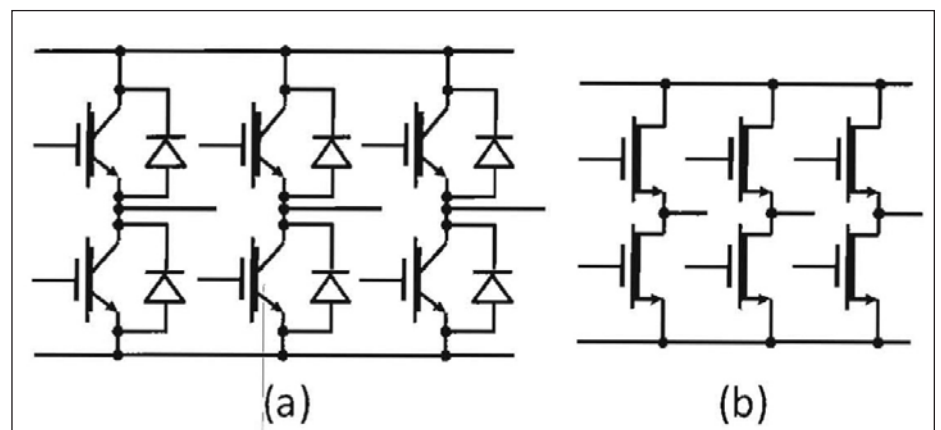

Figure 3 Schematics of 3-phase bridge circuits using (a) IGBTs and freewheeling diodes, and (b) GaN HEMTs without diodes.

a normal  $0.15\ \Omega$ ; pulsed drain current is 70 A. This first-generation GaN device not only exceeds performance of the best-competing Si MOSFETs in terms of “on” resistance, switching speed and parasitic capacitances; it is also capable of operating in reverse-conduction mode, with little reverse-recovery charge ( $Q_{rr}$ ). As seen (Fig. 2), a gate-source-shorted, reverse-recovery charge of a fast-recovery CoolMOS FET and a GaN hybrid HEMT with similar “on” resistances and current ratings, were tested from a reverse conduction of 9 A current to forward blocking of 400 V. It is clear that the GaN device cuts the  $Q_{rr}$  by 25x. Because of these properties the GaN FET is a strong candidate for high-frequency, hard-switched bridge topologies, and achieves this function without a freewheeling diode. Figure 3 compares two 3-phase bridge circuits using Si IGBTs and GaN HEMTs. In addition to expected efficiency and frequency benefits, the GaN implementation slashes the high-voltage device count by half, significantly simplifying the inverter circuit.

A 6-in-1 module was engineered using these GaN device cells with the schematics and package photo shown (Fig. 4). The module design follows high-frequency circuit principles and features kelvin-source leads for stable gate drives to ensure misfire-free, high  $dV/dt$  operation. Based on device specifications, the module is capable of 600 V blocking voltage and 14 A continuous operation current for each switch, at a case temperature of  $100^\circ\text{C}$ . Each half-bridge was inductively switched to confirm a current handling capability greater than 18 A at a rail voltage  $> 400\ \text{V}$ .

### Inverter and Performance

A 3-phase inverter was constructed using the GaN power module based on the schematics (Fig. 5). A Texas Instruments TMS320F28069 DSP was chosen to generate high-resolution PWM signals at 100 kHz. Three complementary PWM peripherals were configured to generate the non-overlapping pulses to each of the three transistor pairs forming the bridge. A lead time of 62.5 ns was directly inserted by the PWM peripheral. Space vector modulation was used to intentionally introduce odd harmonics instead of pure sinusoidal envelopes to maximize usage of the DC rail voltage. A startup sequence with constant V/Hz was incorporated for driving induc-

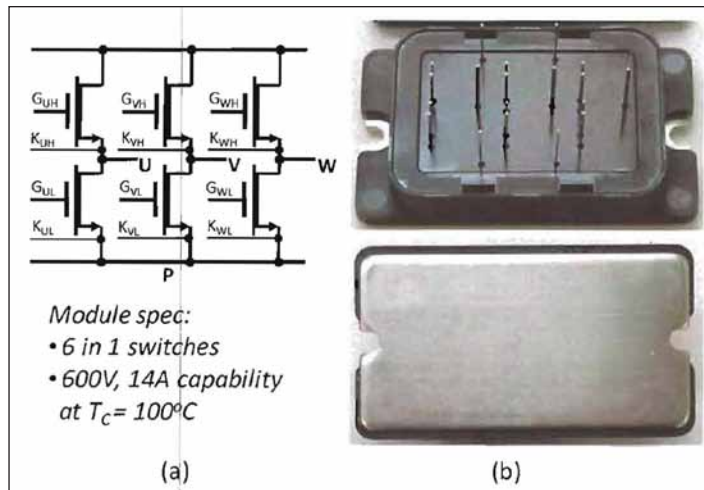

Figure 4 (a) GaN module schematics and (b) packaged module.

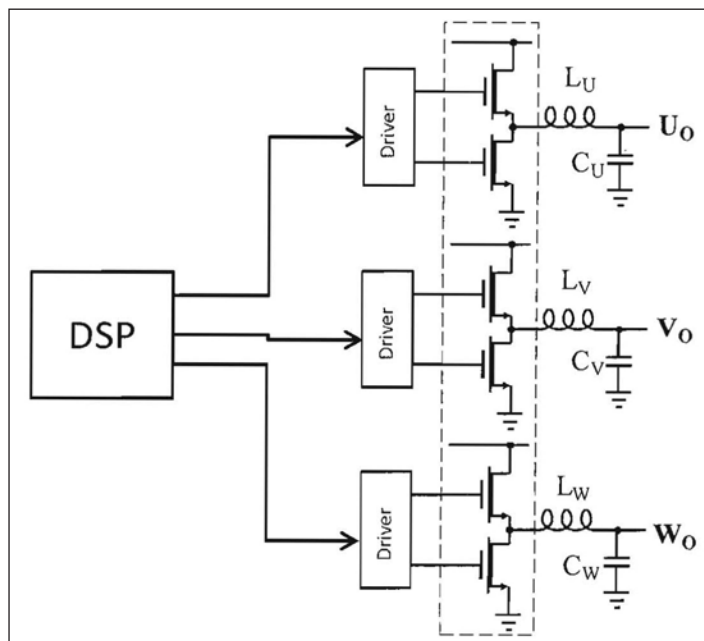

Figure 5 Simplified schematics of 3-phase, high-frequency GaN inverter. Module is indicated with dotted box.  $L_u$  and  $C_u$  (200uH and 0.3uF) form a compact filter.  $U_o$ ,  $V_o$  and  $W_o$  are the three output terminals.

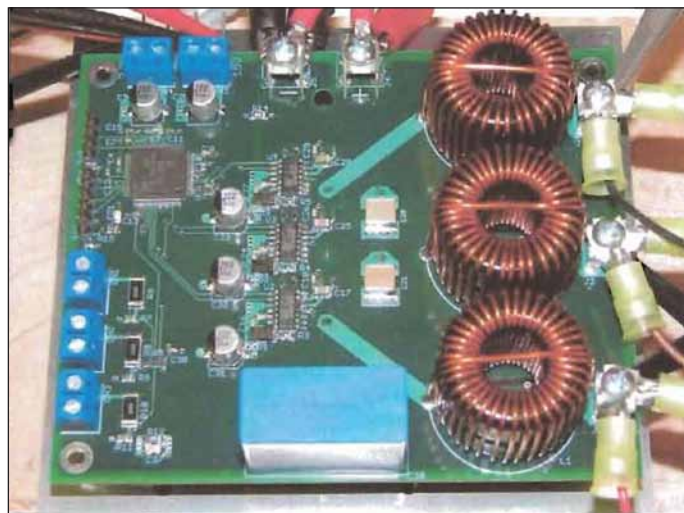

Figure 6 Photo of 2-kW, 3-phase GaN inverter operating at 100 kHz PWM with on-board compact filters for pure-sine-wave output.

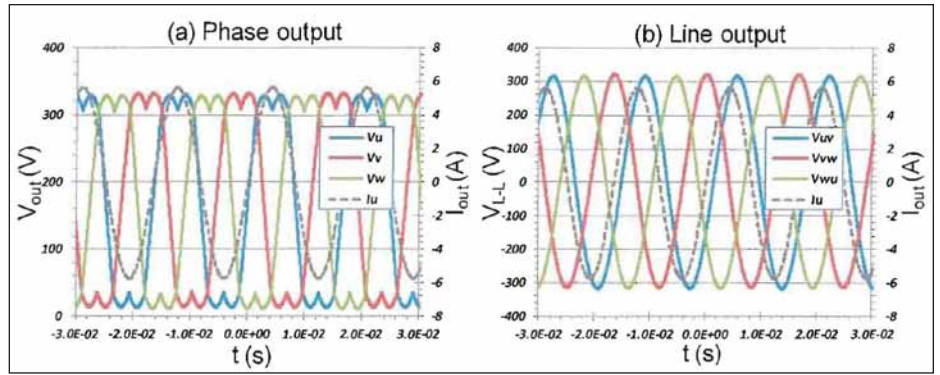

Figure 7 Output voltage waveforms of (a) each phase (or “negative rail”); (b) line-to-line.

tion motors from zero to rated rotation speed. Low-cost sand dust power core inductors and SMD ceramic capacitors were used for the compact L-C filters ( $L_u/C_u$ ,  $L_v/C_v$  and  $L_w/C_w$ ). A photo of the finished inverter is shown (Fig. 6). The outer dimensions are about 4" × 4.5" × 1.6" with no heat sink; with some optimization, a heat sink can be fitted to the same volume.

The inverter was tested at a DC rail of 350 V and a PWM frequency of 100 kHz. Figure 7A shows voltage output waveforms of all three phases after the L-C filters, referred to as the “negative rail.” As mentioned, the odd harmonics are apparent, which were intentionally introduced to fully utilize the DC potential. The line-to-line voltages fed to the delta-connected loads are sinusoidal (Fig. 7B). In contrast to conventional motor-drive-outputting, high-voltage PWM power, the GaN inverter generates pure sine wave power without a bulky filter. This allows motors to operate with ideal excitations and,

therefore, improved electromechanical efficiency and reduced bearing wear. The inverter performance was tested with resistive loads (Fig. 8). Even hard-switched at a high PWM frequency of 100 kHz and with low-cost sand dust inductors, the GaN inverter is capable of efficiencies as high as 98.5%. This performance—obtained at such a high switching frequency for a true DC-to-sine wave inverter—is not possible with conventional semiconductors.

### Electromechanical Test

The GaN inverter was then evaluated in a motor drive test lab at Yaskawa America, Inc. The test motor was model MTRY541 (Marathon Electric), rated at 2.2 kW. A 2.2-kW Si-based motor-drive inverter (A 1,000 series, model CIMR-AU2A0012FA) operating at 15 kHz PWM frequency with no output filter (reactor), was used for a direct comparison to the GaN inverter; it employed an IGBT power module CP30TD-12 A rated at 600 V, 30A. Both inverters were

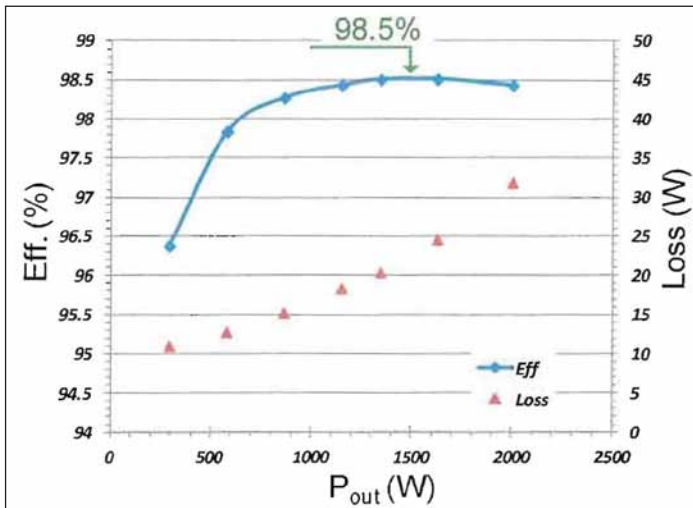

Figure 8 Efficiency and loss as function of output power to resistive loads (digital control and filter loss included).

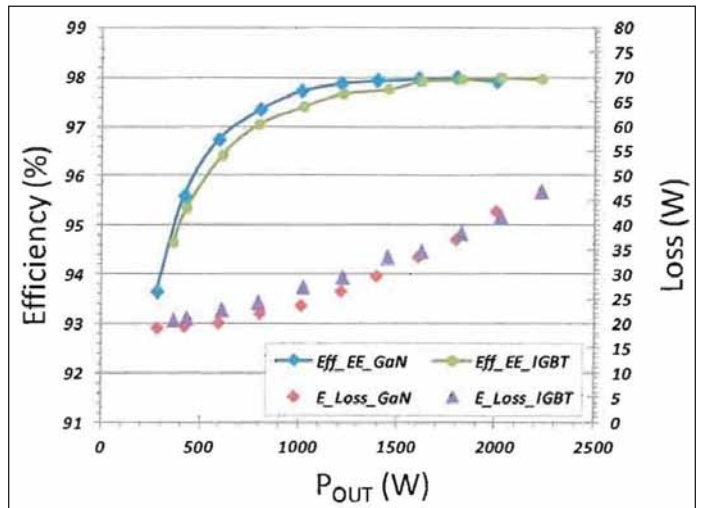

Figure 9 Electrical efficiency as function of output power for GaN inverter at 100 kHz and IGBT inverter at 15 kHz PWM. Efficiency for GaN inverter includes output filter loss; IGBT inverter has no output filter.

configured to be fed with 320 Vdc and produced a 225 Vrms 3-phase AC output at 60 Hz. Electrical power was measured by a WT1800 Yokogawa power analyzer, the mechanical power by a torque transducer power meter. The system was loaded in steps of 0.2 kW up to the rated power. Figure 9 shows the electrical performance as a function of load. Although operating at 7x high PWM frequency and including output filter losses, the GaN inverter matched the IGBT inverter efficiency at 2 kW and outperformed it at lower load. The reduced overall efficiency compared to the case of resistive load (Fig. 8) is due to the less-than-ideal power factor of the motor.

The main advantage of the GaN converter is its pure sine wave output, as shown in the motor current waveform shown (Fig. 10). The direct PWM power from the IGBT inverter led to substantial, high-frequency content in motor current, causing higher dissipation in the motor windings and iron cores. In contrast, the on-board compact filters (enabled by the high PWM frequency) in the GaN inverter produced smooth, pure sine wave drive current. A compel-

ling benefit of this sine wave output is revealed in the motor efficiency plots as a function of load for both IGBT and GaN inverters (Fig. 11A). The improvement in motor efficiency is 8% at low load; -4% at mid-load; >2% at full load. This directly translates to markedly improved system efficiencies (Fig. 11B) and substantial energy savings. The high-quality drive power will also prolong motor life as a result of less bearing wear, an absence of current spikes, and a cooler operation temperature due to reduced motor-induced heating. **PTE**

**Acknowledgement.** This project was funded by ARPA-E and monitored by Dr. Rajeev Ram and Dr. Pawel Gradzki.

## References

1. Deboy, G. et al. "A New Generation of High-Voltage MOSFETs Breaks the Limit Line of Silicon," *Proceedings IEDM 1998*, pp. 683-685.
2. "Bearing Currents in Modern AC Drive Systems." *ABB Technical Guide No. 5*, [http://www.05.abb.com/global/scot/scot201.nsf/veritydisplay/8c253c2417ed0238c125788f003cca8e/\\$file/abb\\_technical\\_guide\\_no5\\_rev.pdf](http://www.05.abb.com/global/scot/scot201.nsf/veritydisplay/8c253c2417ed0238c125788f003cca8e/$file/abb_technical_guide_no5_rev.pdf).
3. "Motor Bearing Current Phenomenon." Yaskawa Application Note AN.AFD.17, [http://www.yaskawa.com/site/dmdrive.nsf/\(DocID\)/NKOE-7HA2UX/\\$File/AN.AFD.17.pdf](http://www.yaskawa.com/site/dmdrive.nsf/(DocID)/NKOE-7HA2UX/$File/AN.AFD.17.pdf).

Y-F. Wu, D. Kebort, J. Guerrero S. Yea and J. Honea serve in various, executive, technical and engineering-related capacities at Transphorm Inc.; K. Shirabe and J. Kang are in similar roles at Yaskawa America.

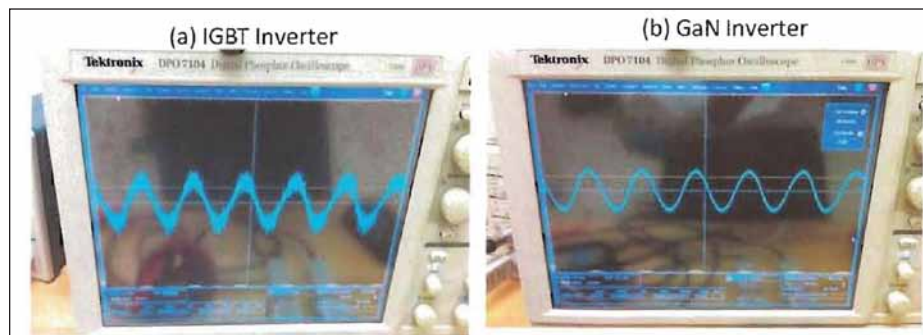

Figure 10 Motor current waveform when driven with (a) IGBT inverter; and (b) GaN inverter.

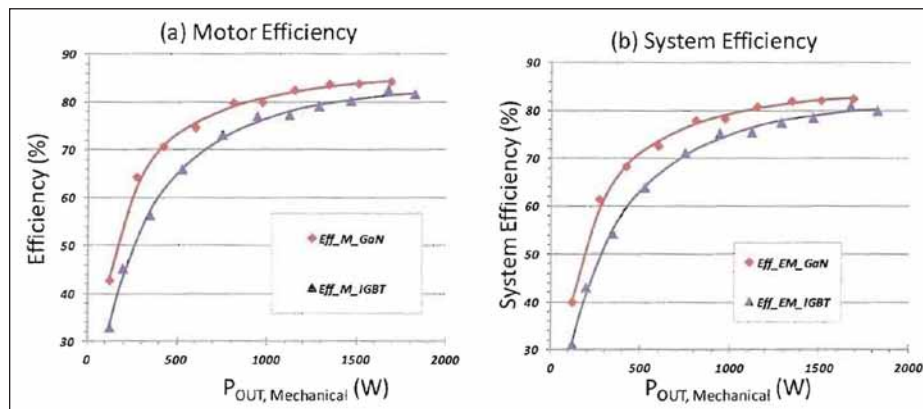

Figure 11 Electromechanical performance using IGBT inverter and GaN inverters; (a) motor efficiency vs. load; (b) system efficiency vs. load. Pure sine-wave output from GaN inverter substantially improved motor efficiency.

# SKF

## OPENS SECOND U.S. SOLUTION FACTORY

SKF has announced the grand opening of the SKF Solution Factory in the Cleveland, Ohio area, a venue designed to equip customers with value-added solutions and industry knowledge. This new facility is the second to open in the United States, joining a growing network of 17 others worldwide. "The SKF Solution Factory is another way for us to provide customers with the resources they need to meet machinery performance and operating efficiency goals," said Poul Jeppesen, president and CEO of SKF North America. "We are pleased to bring this state-of-the-art facility and its unique portfolio of services to this region."

The SKF Solution Factory in Cleveland provides access to SKF's diverse technical resources for machine productiv-

ity solutions. The facility offers an extensive range of services, including bearing application support, customized machined sealing solutions, spindle and ball screw repair, mechanical equipment services, engineering consultancy, remote diagnostics and monitoring, and a full spectrum of training courses and seminars. This new SKF Solution Factory serves a wide range of industries, including machine tool, food and beverage, mining, and metals, among others. The facility is located at 670 Alpha Drive, Highland Heights, Ohio 44143. The other SKF Solution Factory in the United States is located in Houston, Texas.



# SKF

## WINS LAS VEGAS BEARING CONTRACT

SKF has recently been awarded the contract to supply the two giant main bearings and related technologies for Caesars Entertainment Corporation's Las Vegas High Roller observation wheel expected to soar at the heart of the world-famous Las Vegas Strip in late 2013. The 550-foot-tall wheel, eclipsing the famed 443-foot-tall London Eye, will be equipped with two SKF spherical roller bearings that will turn out to be the largest ever produced at the SKF manufacturing facility in Gothenburg, Sweden.

The two custom-designed SKF spherical roller bearings (one within each side) will be virtually unprecedented in weight and size. Each bearing will weigh approximately 8,800 kg and be designed with 2,300 mm outer diameter, 1,600 mm inner diameter, and width of 630 mm. Specially engineered features will include W26 lubrication holes in the inner ring, SKF NoWear-coated rollers, and PTFE coating in the bore. SKF additionally will incorporate advanced lubrication, sealing, and on-line condition-monitoring systems and take the lead in monitoring the bearings once the wheel is up and running.

SKF was awarded the contract by American Bridge Company (Coraopolis, PA, USA), which is responsible for constructing the 143 m-diameter tension wheel. In addition to the two SKF bearing assemblies, the structure will consist of four steel support legs, a single braced leg, fixed spindle, rotating hub,

2 m-diameter tubular rim, and 112 locked coil cable assemblies as spokes.

The Las Vegas High Roller is the centerpiece of The LINQ, a planned \$550 million, open-air retail, dining, and entertainment district situated between Imperial Palace and Flamingo Las Vegas. Each of the wheel's 28 supersize cabins (which themselves will revolve) will accommodate up to 40 people during a 30-minute ride.

The Las Vegas High Roller turns out to be the latest SKF big-wheel project in a growing portfolio of expertise. The Navy Pier Ferris wheel in Chicago similarly operates with two SKF spherical roller bearings and SKF Reliability Systems retains responsibility for ongoing proactive maintenance programs. For more information, visit [www.skf.com](http://www.skf.com).





11th International CTI Symposium and Exhibition

# Innovative Automotive Transmissions, Hybrid & Electric Drives

3 – 6 December 2012, Berlin, Germany



**Simultaneous Translation German** ↔ **English**  
English conference documentations

## Experts in the Plenum e. g.



**Prof. Dr Jürgen Leohold**  
Head of Corporate Research  
Volkswagen AG



**Sung-Ho Cho**  
Vice President,  
Head of R&D Center  
Hyundai Powertech



**Dr Gary J. Smyth**  
Executive Director Global  
Research & Development  
General Motors Company



**Patrick Signargout**  
Vice President  
Car Manufacturers Relations  
and Co-operations  
PSA Peugeot Citroën



**Jan Kretschmer**  
Vice President  
Design Transmission  
BMW Group

**Roberto Fedeli**  
Technical Director  
Ferrari S.p.A.



**Enrico Sedoni**  
Senior Director Axle &  
Transmission Component  
Product Line, CNH



**Dirk Lappe**  
Managing Director  
Porsche Engineering  
Services GmbH



**Bernd Eckl**  
Executive Vice President  
Sales, Marketing,  
Business Development  
GETRAG International GmbH



**Didier Lexa**  
Chief Technology Officer  
GETRAG International GmbH



**Yo Usuba**  
Executive Vice President  
Jatco Ltd



**Dr Robert Fischer**  
Executive Vice President  
AVL List GmbH



**Philip Gott**  
Senior Director Long Range  
Planning & Sustainability Solutions  
IHS Global Insight, Inc.



**Ashok Bhandwale**  
former Head of Transmissions  
TATA Motors Ltd



**Alain Diboine**  
Director Research & Development  
AVTOVAZ



**Prof. Dr Stefan Pischinger**  
Chair of the Institute of Combustion  
Engines and Director of the Institute  
of Thermodynamics, RWTH Aachen



**Alexander Edwards**  
President  
Strategic Vision, Inc.



**Piero Toselli**  
CEO & Managing Director Magneti,  
Marelli Powertrain SpA, Italy

### Sponsors:



## Wichita Clutch

RECEIVES TEXAS MANUFACTURING STAR AWARD

The Texas Workforce Commission (TWC) recently honored Wichita Clutch with the Texas Manufacturing Star Award at the Texas Business Conference in Wichita Falls, Texas. TWC Commissioner Representing Employers, Tom Pauken presented the award to Wichita Clutch, a global leader in the design and manufacture of heavy-duty industrial pneumatic and hydraulically-actuated clutches and brakes.

The award acknowledges outstanding private-sector employers who contribute to the growing manufacturing base in Texas. "Wichita Clutch is always looking for better, more



cost-effective ways to get their products produced," said Pauken. "They are a vital participant in the overall health of the Wichita Falls community and its economic development." Businesses are selected for the award based on the economic impact they have on their communities, partnerships they develop with economic development organizations or training providers as well as their workforce training and development.

"We are very proud to receive this prestigious award," said Mark Stuebe, vice president and general manager of Altra Industrial Motion's Heavy-Duty Clutch Brake Group. "Our focus is on maximizing our resources and capital while contributing to the economic vitality of Wichita Falls." For more information, visit [www.altramotion.com](http://www.altramotion.com).

## Bison

SUPPORTS PTDA INITIATIVE

With the anticipated retirement of more than 80 million baby boomers over the next 20 years and only 43 million younger workers in line to replace them, the time is fast approaching when recruiting talented individuals will once again be a serious challenge for every business. For the power transmission/motion control industry, the problem is even more profound as it endures a lack of recognition among young

people as well as a well-publicized skills gap. The Industrial Career Pathway (ICP) initiative—founded and significantly funded by the PTDA Foundation—is taking major steps to ensure the workforce is aware of the satisfying and rewarding careers available in industrial distribution. And to help, Bison Gear and Engineering has stepped up by making a contribution to fund the initiative's activities in 2012. With this contribution, Bison is taking a leading role in the movement to drive talented workers to key positions in manufacturing and industrial distribution. The PTDA Foundation, whose work is funded solely by donations, was founded in 1982 to enhance knowledge, education, professionalism and productivity within the power transmission/motion control industry. The foundation is a not-for-profit, tax-exempt 501 (c)(3) corporation; contributions are tax deductible to the full amount allowed by law. The PTDA Foundation's core initiative, Industrial Careers Pathway, is a collaboration of industrial distribution associations working together to bring tomorrow's North American employees to the industrial distribution channel, develop programs to teach business and distribution basics and create affordable resources for current employee development. For more information, visit [www.ptda.org](http://www.ptda.org).

## Motion Industries

NAMED SUPPLIER OF THE YEAR

Motion Industries, a distributor of industrial maintenance, repair, and operation (MRO) replacement parts, was named Supplier of the Year FY12 (Indirect Procurement category) by Heinz North America. Motion was the only company to receive a Supplier of the Year Award in the Indirect Procurement category. Motion had exceeded in delivering Heinz North America's key objectives of cost savings, quality, efficiency, and innovation, during fiscal year 2012. This is the first time that Motion or any Indirect supplier to Heinz North America has won this award for two consecutive years. "Out of the hundreds of Indirect suppliers to Heinz, Motion had to make a huge impact to Heinz to be nominated and selected for this award, given the competitive environment and quality suppliers managed by Indirect Procurement," said Keith Nasse, Indirect procurement senior buyer at Heinz North America. "Motion has clearly partnered with Heinz to help us improve our efficiencies and capture productivity gains."

Bill Stevens, Motion Industries president and CEO, said, "We strive to provide our customers with the best service possible, and we are pleased that Heinz North America has honored us with this significant award."

The Supplier of the Year Award is the most prestigious award that Heinz offers to its suppliers. For more information, visit [www.motionindustries.com](http://www.motionindustries.com).



# PRECISION POWER PARTNERSHIPS

# GEAREXPO 2013

## ALONG WITH SOARING PROFITS, YOU GET:

- The latest in **cutting-edge** technologies and processes
- Gear-specific **education** programs
- **Machinery** to see in action and compare
- **Innovative** products and software
- **Lucrative** connections with thousands of other gear manufacturers and buyers from the U.S. and abroad
- **Cost-effective** solutions, small and large, for immediate implementation

## DON'T MISS GEAR EXPO 2013,

the world's only conference and expo exclusively for the gear industry, where you'll see **750,000 pounds of machinery and gear products on the show floor!**



## MARK YOUR CALENDARS

SEPTEMBER 17-19, 2013  
INDIANA CONVENTION CENTER  
INDIANAPOLIS, IN

[WWW.GEAREXPO.COM](http://WWW.GEAREXPO.COM)

Owned by:



American  
Gear Manufacturers  
Association

## AMT

ISSUES SECOND GENERATION OF THE MANUFACTURING MANDATE

As part of its effort to solidify the renaissance in American manufacturing, the Association for Manufacturing Technology (AMT) has issued the second generation of The Manufacturing Mandate. The Manufacturing Mandate was introduced in 2009 just as the recession was ending. Since then, the U.S. manufacturing sector has been the driving force behind the economic recovery. Today, policymakers, industry leaders and academia agree on the major aspects of a national strategy that will accelerate and sustain this manufacturing resurgence. They are aligned with The Manufacturing Mandate core principles of incentivizing R&D and innovation; increasing global competitiveness and building a Smartforce that is equipped with the knowledge and skills necessary for careers in manufacturing.

The Manufacturing Mandate underscores the importance of collaboration as central to the implementation of a national strategy. The Obama Administration's recent announcement of a new public-private institute for manufacturing innovation in Youngstown, Ohio, is a prime example of the important role government can play in facilitating that collaboration between the public sector, academia and industry. This new partnership, the National Additive Manufacturing Innovation Institute (NAMII), was selected through a competitive process—led by the Department of Defense—to award an initial \$30 million in federal funding, matched by \$40 million from the winning consortium, which includes 40 manufacturing firms, nine research universities, five community colleges, and 11 non-profit organizations from the Ohio-Pennsylvania-West Virginia 'Tech Belt.' The NAMII aims to increase successful transition of additive manufacturing technology to manufacturing enterprises within USA. It is scheduled to launch in September and is led by the National Center for Defense Manufacturing and Machining. AMT and The MTConnect Institute are key launch partners in this innovative project. "AMT will continue to invest significant resources in a secure future for manufacturing in this country," said Douglas K. Woods, AMT president. "There is still much work to be done, but this type of support from the federal government is precisely the type of project the Manufacturing Mandate recommends. It certainly bodes well for America's future as the world's manufacturing innovator." For more information, visit [www.amtonline.org](http://www.amtonline.org).



Douglas K. Woods

## Pacamor Kubar Bearings

EXPANDS CERTIFICATIONS

Pacamor Kubar Bearings (PKB) recently announced that they have successfully completed recertification to ISO 9001:2008 and AS9100:2009. This certification represents an upgrade to the company's previous AS9100:2004 classification. To achieve certification, PKB demonstrated a comprehensive and effective quality management system that governs all areas of its operation. PKB was evaluated throughout every phase of the manufacturing process, including procurement, production and testing to accounting, logistics, information systems and human resources. The latest analysis also included a thorough audit of all policies and practices, confirming that they are applied with a commitment towards ongoing improvement. The quality system assessment was completed at PKB's Troy, New York facility on April 4, 2012, including a review of all special capabilities necessary to develop and/or manufacture miniature and instrument ball bearings for the aerospace industry. The AS9100 standard is an Aerospace Industry Specification derived from ISO 9001. The AS9100:2009 standard specifies the quality management system requirements for suppliers to the defense, aviation and space industry. This upgraded AS9100:2009 standard supplements ISO 9001 by addressing the specific additional expectations of the aerospace industry, with special focus on improved quality, schedule and cost performance.

Edward M. Osta, executive vice president, states "This certification is confirmation of Pacamor Kubar Bearings superior quality in operations and process-driven excellence to ensure customer satisfaction. Our AS9100 and ISO 9001 Certifications, along with our FAA TSO-C149 Aircraft Bearings Certification, are necessary for PKB's continued growth in this important industry. ISO 9001:2008 and AS9100:2009 Certifications recognize our Quality System as being on par with the best quality systems in the aerospace industry. These certifications enhance the confidence of our current customers in our capabilities while providing us access to contracts only obtainable by AS9100 accredited organizations."

## NovaTorque

PRESENTS AT WBT INNOVATION MARKETPLACE

NovaTorque Inc. presented at the tenth annual WBT Innovation Marketplace by Northrup Grumman that took place October 24–26, 2012 at the San Diego Convention Center. NovaTorque is among 130 companies and technology innovators from across the globe that was individually chosen by the WBT Selection Committee to present during WBT 2012. Emily Liggett, NovaTorque CEO, spoke about NovaTorque's cost effective, energy efficient, non-rare earth permanent magnet motor technology and future plans for its proprietary technology to some of the country's leading venture capital firms, Fortune 1000 corporate licensees, federal agency representatives and university technology transfer managers.

“Electric motors are everywhere, and nearly half of the electricity produced in the world is used to drive electric motors,” explained Liggett. “NovaTorque’s innovative technology provides the real potential to significantly reduce the energy consumed and carbon emissions produced by the use of electric motors—with enormous positive potential consequences, both economic and environmental. Importantly, due to our unique patented flux-focusing stator and rotor hub geometry, the NovaTorque motor produces this



performance with an all-ferrite (versus rare earth) magnet design. The ability to use ferrite magnets allows NovaTorque to price our motors to compete effectively with induction motors with extraordinarily rapid payback on the initial investment,” continues Liggett.

“We were pleased to include NovaTorque in this choice group of emerging companies and technologies to our exclusive forum of institutional investors, angel investors, and corporate licensees,” said Paul Huleatt, CEO, WBT Innovation Marketplace. “We hope NovaTorque will join the WBT alumni that have received over \$786 million in early and seed stage funding and licensing. One in three WBT presenters goes on to license, secure venture funding or sell their IP outright.”

“We were honored to present alongside a wide array of highly regarded researchers and technologists from around the world who are making ground breaking discoveries,” said Liggett.

As in previous years, the 2012 WBT Innovation Marketplace represents the collaborative, yearlong effort of investors, licensees, and tech commercialization professionals. The WBT is deal-focused and diverse, showcasing companies and technologies that vary by geography, funding source and type of research institution. Participating technologies are selected by and presented to seasoned venture investors and Fortune 500 licensing scouts representing a variety of growth oriented industries. WBT 2012 was hosted by the San Diego Regional Economic Development Corporation and CONNECT, an internationally recognized and award winning regional program that catalyzes the creation of innovative technology and life sciences products in San Diego County by linking inventors and entrepreneurs with the resources they need for success. For more information, visit [www.wbtshowcase.com](http://www.wbtshowcase.com).

## Bosch Rexroth

NAMES BOEHM VICE PRESIDENT MACHINERY APPLICATIONS AND ENGINEERING

Bosch Rexroth Corporation recently announced that Michael Boehm has been named vice president machinery applications and engineering. In his new role, Boehm will oversee product development, sales and operations for the company’s machinery applications and engineering business unit which includes bulk material handling, marine and offshore, filtration systems, service, industrial manufacturing equipment and hydraulic power technologies. Boehm, who most recently served as director sales product management mobile applications, has gained experience at numerous levels of technical sales management over his



Michael Boehm

27-year career in industrial and mobile hydraulics. He has more than 22 years of experience within Bosch and Bosch Rexroth, where he has been responsible for product management, sales channel and distribution development, including 12 years of international experience in the East Asian and Australian markets. He holds a bachelor of science in mechanical engineering from Purdue University and has completed executive management training at universities both in the U.S. and abroad. Boehm succeeds Winfried Hegel, who will become head of sales and industry sector management industrial manufacturing equipment for Bosch Rexroth’s industrial applications business unit in Germany.

## Spungen

NAMED PRESIDENT OF PEER CHAIN COMPANY

Peer Chain Company, an industrial chain provider, recently announced that Glenn Spungen joined the company as president effective October 1, 2012. Spungen will manage all facets of the operation and oversee the expansion of the third-generation family business. His vision is to enhance customer service, build upon existing distributor relationships, and grow the original equipment manufacturer business. Spungen adds a wealth of sales management and operational



Glenn Spungen

experience to the team, having held key leadership roles at Peer Bearing Co. for 27 years. As Vice President of Sales and Operations, Spungen spearheaded sales in the United States and China, travelled extensively overseas to preside over the company's manufacturing plants, and oversaw the operations in the United States. In 2008 when the Spungens sold Peer Bearing Co. to SKF in Sweden, the company had over 1400 employees. "I'm incredibly excited to work with the Peer Chain team and build on our commitment to delivering the best customer experience in the industry," said Spungen. "We've identified major opportunities worldwide where we can develop new business and make a significant impact in the industry. I'm also eager to work with my family, colleagues and partners to ensure that the Peer Chain brand is the most trusted and respected in the industry."

## Misumi Group

TO ACQUIRE DAYTON PROGRESS CORPORATION

Misumi Group Inc. of Japan recently announced that it has signed a definitive agreement to acquire Dayton Progress Corporation and its subsidiary, PCS Company from Connell Limited Partnership pending certain regulatory approvals. The acquisition, expected to close in November, will also include the Anchor Lamina Die Components business of Connell, known for its Danly, IEM, Lemppo and Lamina Brands.

The Die Set and Fabrication divisions of Anchor Danly are not included in this acquisition, will continue to remain subsidiaries of Connell Limited Partnership and will continue as a strategic partner of the Components Division of Misumi.

"Dayton Progress Corporation and the Anchor Lamina die components business both leverage product standardization and product blanks, making their production methods highly compatible with our own," said Masayuki Takaya, president and Co-CEO of Misumi Group. "Aside from short lead-time production regimes, Dayton Progress and the Anchor Lamina die components business also have strong technological capabilities, excellent customer service and solid customer bases in the United States and Europe. They are both attractive businesses for their leading positions in the manufacture of die components."

"We have already established our Misumi QCT Model, which delivers high quality (Q) at low cost (C) with short delivery times (T) and no minimum quantity requirements, and built out a supply regime capable of delivering on short lead-times primarily in Japan, China and the rest of Asia. Bringing Dayton Progress and the Anchor Lamina die components business into the Misumi Group establishes a global short delivery-time supply regime virtually overnight and should accelerate deployment of the Misumi QCT Model globally."

"Misumi Group is a growing, successful company that has established a supply chain which delivers low cost and short lead times in Japan, China and the rest of Asia. Ownership by Misumi is a great thing for our company and for customers and distributors of Dayton Progress and Anchor Lamina," said Alan Shaffer, president and CEO of Dayton Progress.

## Paul McHenry

WINS GEAR TECHNOLOGY/PTE IMTS IPAD RAFFLE

Paul McHenry, shop supervisor at Tri-City Machine Products, Inc. was the lucky winner of a new iPad at the *Gear Technology/Power Transmission Engineering* booth during IMTS. McHenry, a *PTE* magazine subscriber, was thrilled to hear that his name was drawn following the show. "It goes to show that it is always worth stopping by and talking to vendors and filling out those entry forms at IMTS!" McHenry said. "I enjoy keeping up with the latest technology."

Tri-City Machine is a full service machine shop located in Peoria, Illinois that offers extensive CNC machine capabilities and standard manual machine and job shop equipment. The



Paul McHenry

The *Gear Technology* and *PTE* team would like to congratulate McHenry and also thank all the IMTS attendees that stopped by the booth and helped make the show such a resounding success.

## BSA

APPROVES WATER AND WASTEWATER INDUSTRY BRIEFS

When the Bearing Specialists Association (BSA) met September 24-25 in Chicago, Illinois, it approved the publication of two, new Industry Briefs: *Water Treatment* and *Wastewater Treatment*. Both briefs were initiated and drafted by the association's Educational Services Committee and join a mounting body of free, downloadable, educational materials designed to meet the needs of bearing distributors and end users by defining specific end-use bearing applications, critical design factors in those installations, preferred bearing choices and more. For example, in the case of the water treatment and wastewater treatment installations, selected bearings must be suitable for wet environments which, in some cases, also accommodate harsh chemicals. As in the case of all other BSA Industry Briefs, these documents also provide essential background on the overall processes of a specific industry along with an overview of potential bearing installations. *Water Treatment* and *Wastewater Treatment* join Industry Briefs on Wind Power, Poultry, and Cement Processes. All are available as free, downloadable PDF's from the BSA website, [www.bsahome.org](http://www.bsahome.org).

# Trelleborg Sealing Solutions

ANNOUNCES PARTNERSHIP WITH THE OMEGA ENVOY TEAM

Trelleborg Sealing Solutions announces its partnership with Earthrise Space, Inc. (ESI) in sponsorship of Omega Envoy, a non-profit space technology developer competing in the Google Lunar X PRIZE (GLXP). The team will compete by safely landing a robot on the surface of the moon and responding back with images and data. Trelleborg Sealing Solutions, a global developer and manufacturer of advanced sealing solutions, will provide sealing education, selection guidance and products for the team's use. "It's a great experience to provide education and watch this team through the many phases from creation to launch of their project," says Antonio Garcia, aerospace segment manager for Trelleborg Sealing Solutions Americas. "The Omega Envoy is a team comprised of diverse specialties and an innovative group to work with. As our products play an integral part in space exploration, it's a great experience to be a part of this project."

"We are excited to welcome Trelleborg Sealing Solutions as our latest partner in the Omega Envoy project," says Ruben



D. Nunez, president and founder of ESI. "The seal education and products they are providing will be put to direct use by our student team members as they build and test hardware for our GLXP mission. Trelleborg's experience is exactly what we need to enhance our team and design for our mission to the moon scheduled to launch in 2014."

Earthrise Space, Inc. is a Florida-based non-profit corporation dedicated to developing space technology in collaboration with industry and academic institutions. ESI's Omega Envoy Project is creating a key set of lunar spacecraft infrastructure, which will fulfill the requirements of the Google Lunar X PRIZE and provide a platform for the delivery of commercial payloads to the lunar surface.

**Bevel Gear Solutions**

	<p>Straight Bevel 1/2" to 90"</p>
<p>Spiral Bevel 1/2" to 60"</p>	
	<p>Ground Spiral Bevel 2" to 28"</p>
<p>Hypoid Gears with 4-tooth pinions</p>	

*Bevel Gears (India) Pvt. Ltd.*



 Bevel Gears (India) Pvt. Ltd.    P: +91 80 2841 0312 / 039  
 17 B Sadaramangla Industrial Area,    F: +91 80 2841 0185  
 Whitefield Road, Bangalore, 560048    E: jamalgrp@vsnl.com

[www.bevelgearsindia.com](http://www.bevelgearsindia.com)



A Division of A&E Incorporated

**Designed to Protect™**

Overload Release Clutches



Phone: 262.554.7500  
 Fax: 262.554.7503  
[www.cabatinc.com](http://www.cabatinc.com)

## Gilman USA

ADDS KACEY ENTERPRISES FOR SALES REPRESENTATION

Gilman USA has added Kacey Enterprises Inc., as an outside sales representative to cover portions of the Upper Midwest. Effective Oct. 1, Kacey Enterprises will be promoting Gilman USA products and services by providing marketing and sales support to areas in Northern Illinois, Northwest Indiana, Iowa, Wisconsin (excluding the far northwest part of the state) and Michigan's Upper Peninsula. Based in Glen Ellyn, Illinois, Kacey Enterprises boasts an outside sales staff of six employees and has three customer service representatives. With nearly 40 employees averaging 22 years of experience, Gilman USA serves value-minded engineers with exacting needs and standards throughout numerous industries. The highly skilled, knowledgeable and experienced Gilman USA team will continue to specialize in customized components and engineered solutions for its customers. Gilman USA showcased its service and product offering at the International Manufacturing Technology Show (IMTS) last month in Chicago. The company also recently launched a new website that features a streamlined look to its navigation with its three most popular search tabs: *spindles*, *slide stages* and *service*, prominently displayed for easy access. Gilman USA, previously known as SKF Precision Technologies, was purchased by Christopher Hetzer, Mark Ziebell and Michael Weiland on Sept. 13, 2011.



## IMS Research

REPORTS GEARBOX AND GEARED MOTOR SHIPMENTS UP

Precision gearboxes and geared motor shipments were 69 percent higher in 2011 than in 2009 because of increased manufacturing output in 2010 and 2011. IMS Research, recently acquired by IHS Inc., projects further growth in the market for precision gearboxes and geared motors, but expects precision geared product sales to slow through 2016. Demand for precision gearboxes surged as machine tool and industrial robot sales exceeded expectations in 2010 and 2011. Pent-up demand for machine tools and investment in industrial robots for new automobile production lines following the global recession were major driver behind the sharp increase in precision gearbox sales. "There are two reasons behind the strong growth in sales of precision gearboxes and geared motors," said Bryan Turnbough, an analyst with HIS. "One being that demand for precision geared products continues to be more niche than standard industrial geared products, which allows for greater volatility in the precision geared products market; the other being that the standard geared products are continuing to be replaced with precision geared products in greater numbers due to growing demand for higher torque densities and precision." For the full report, visit [www.ihs.com](http://www.ihs.com).

# Global Industrials Intelligence

Extracting simplicity from clutter.

- **Surveillance and demand trends on 45 end markets in eight key sectors:**

Energy	Industrial
HVAC/Construction	Technology
Consumer Cyclical	Aerospace Defense
Machinery	Healthcare

- **Understanding strategies of key public corporations.**
- **How Manufacturers are reacting to change.**

312.235.6521

Brian K. Langenberg, CFA

Langenberg &  
**LC**ompany

Visit [www.Langenberg-LLC.com](http://www.Langenberg-LLC.com) for proprietary research.

### November 6–8 SMMA Fall Technical Conference.

Sheraton Westport Plaza Tower Hotel, St. Louis. SMMA-The Motor & Motion Association is the manufacturing trade association for the electric motor and motion control industries. More than 120 member companies include manufacturers, suppliers, users, consultants and universities serving both consumer and commercial markets in the appliance, transportation, medical equipment, office automation and computers, aerospace and industrial automation industries. Scheduled courses at the Fall Technical Conference include fundamentals of electric motor design, fundamentals of brushless motor control, permanent magnet fundamentals and much more. The Fall Technical Conference provides members and prospective members the opportunity to interact with industry colleagues. Attendees learn about industry trends and technologies, identify new supplier partners and network with other motors and drives professionals. For more information, visit [www.smma.org](http://www.smma.org).

### November 12–15 Bulk Material Handling.

Indianapolis. IDC University's Bulk Material Handling course is a four-day intensive study into the various types of conveyors and bucket elevators. This course introduces students to the bulk material handling industry and the details behind the design and application of screw conveyors, bucket elevators, drag conveyors and belt conveyors. Throughout the course, students will learn about various bulk materials and how to classify them by CEMA standards. Resources available for designing and selling screw conveyors, bucket elevators, drag conveyors and belt conveyors will be covered. For more information, visit [www.idc-usa.com](http://www.idc-usa.com).

### November 14–15 Design and Manufacturing Montreal.

Palais des Congres Convention Centre, Montreal. The province of Quebec is a major center of manufacturing, with a gross domestic product of \$301 billion. Quebec offers a strategic location between Europe and the Americas and is within a 600 mile radius of Boston, New York, Washington, and Detroit. UBM Canon is pleased to announce the comprehensive 2012 co-located event lineup including Expoplast, Packex Montreal, Process Technology/Powder Bulk Solids (PTX/PBS) Montreal, Design and Manufacturing Montreal, Contract Manufacturing Expo, Automation Technology Expo (ATX) Montreal, AeroCon, and Sustainability in Manufacturing. Design & Manufacturing Montreal features leading suppliers of CAD/CAM systems and software, enterprise software, rapid prototyping, design services, custom molding, machining and components, and fastening and joining systems. For more information, visit [www.ubmcanon.com](http://www.ubmcanon.com).

### November 26–29 Defense Manufacturing Conference.

Orlando, Florida. The Defense Manufacturing Conference (DMC) is the nation's largest forum for scientists, technologists, engineers, managers, leaders and policy makers in the defense industrial base. The meeting is the product of a partnership of the U.S. military departments and agencies of the Department of Defense. DMC 2012 will feature presentations on topics like required industrial capabilities, future warfare scenarios and manufacturing innovation. All of the military departments, defense agencies, industry and academia will participate in this event for both defense and non-defense related manufacturing technology. Past exhibitors include Aero Gear, DMG/Mori Seiki, Dura-Bar and Solar Atmospheres. For more information, visit [www.dmc2012.com](http://www.dmc2012.com).

**December 3–6  
Motors and Controls.** Indianapolis. Selling electric motors and controls begins with understanding how they operate. This course takes students from the fundamentals of electricity through selecting motors and controls for industrial applications. Special consideration is given to basic theory, principles of operation, construction and programming of motors and digital controls. Hands-on lab sessions reinforce each day of learning. For more information, visit [www.idc-usa.com](http://www.idc-usa.com).

**January 21–24  
Automate 2013.** McCormick Place, Chicago. Automate is the largest solutions-based showcase of automation technologies in North America. Formerly the International Robots, Vision & Motion Control Show, which dates back to 1977, Automate now demonstrates the full spectrum of automation technologies and solutions for a broad array of industries. The show is held once every two years. Companies that provide integration of automation, robotics and machine vision will show actual demonstrations of systems at the show. This allows attendees to see live demos solving challenges they face in their industry, and also to learn from solutions used in other industries that may be beneficial to them. The rest of the show features the latest automation, robotic, vision and motion control technologies and systems on display from leading global suppliers. A comprehensive educational conference accompanies the Automate show. Featuring a broad array of classes from beginner to advanced skill levels, the conference offers something for all attendees—they can take one class or four full days of training. ProMat, a material handling and logistics show, is co-located with Automate 2013. For more information, visit [www.automate2013.com](http://www.automate2013.com).



For exclusive articles and the latest news...

Subscribe to our e-mail Newsletter

[www.powertransmission.com/newsletter/subscribe.htm](http://www.powertransmission.com/newsletter/subscribe.htm)

If you sell...



**GEARS**  
**MOTORS**  
**BEARINGS**  
**CLUTCHES**  
**COUPLINGS**  
**SPEED REDUCERS**  
**LINEAR MOTION**  
 or other power transmission components...

Your customers are looking for you on  
[powertransmission.com](http://powertransmission.com).

Get listed in the **BUYERS GUIDE** at  
[www.powertransmission.com/getlisted.php](http://www.powertransmission.com/getlisted.php)

**AGMA**

Page 47  
[www.gearexpo.com](http://www.gearexpo.com)

**Automate 2013**

Page 22  
[www.automate2013.com](http://www.automate2013.com)

**Automation Direct**

Inside Front Cover  
[www.automationdirect.com](http://www.automationdirect.com)

**B&R Machine and Gear**

Page 17  
[www.brgear.com](http://www.brgear.com)

**Baldor**

Page 5  
[www.baldor.com](http://www.baldor.com)

**Bevel Gears India**

Page 51  
[www.bevelgearsindia.com](http://www.bevelgearsindia.com)

**Cabat Inc.**

Page 51  
[www.cabatinc.com](http://www.cabatinc.com)

**Car Training Institute**

Page 45  
[www.getriebe-symposium.de/engl](http://www.getriebe-symposium.de/engl)

**Cincinnati Gearing Systems**

Page 23  
[www.cincinnati-gearingsystems.com](http://www.cincinnati-gearingsystems.com)

**Circle Gear Co.**

Page 9  
[www.circlegear.com](http://www.circlegear.com)

**Clifford-Jacobs Forging Co.**

Page 25  
[www.clifford-jacobs.com](http://www.clifford-jacobs.com)

**Diamond Chain Co.**

Page 25  
[www.diamondchain.com](http://www.diamondchain.com)

**Diequa Corp.**

Page 20  
[www.diequa.com](http://www.diequa.com)

**Dunker Motor USA**

Page 15  
[www.dunkermotoren.com](http://www.dunkermotoren.com)

**Excel Gear**

Page 13  
[www.excelgear.com](http://www.excelgear.com)

**Forest City Gear**

Page 7  
[www.fcgear.com](http://www.fcgear.com)

**Gear Expo**

Page 47  
[www.gearexpo.com](http://www.gearexpo.com)

**Gear Motions Inc.**

Page 55  
[www.gearmotions.com](http://www.gearmotions.com)

**The Gear Works—Seattle, Inc.**

Page 55  
[www.thegearworks.com](http://www.thegearworks.com)

**IG Watteeuw International N.V.**

Page 19  
[www.watteeuw.be](http://www.watteeuw.be)

**Langenberg & Co. LLC**

Page 52  
[www.langenberg-llc.com](http://www.langenberg-llc.com)

**McInnes Rolled Rings**

Page 33  
[www.mcinnesorolldrings.com](http://www.mcinnesorolldrings.com)

**Motion Industries**

Page 3  
[www.motionindustries.com](http://www.motionindustries.com)

**Ontario Drive and Gear**

Page 24  
[www.ODG.com](http://www.ODG.com)

**Quality Transmission Components**

Page 2  
[www.qtcgears.com](http://www.qtcgears.com)

**R+W America**

Page 16  
[www.rw-america.com](http://www.rw-america.com)

**Rexnord**

Inside Back Cover  
[www.rexnord.com](http://www.rexnord.com)

**Schafer Gear Works**

Page 11  
[www.schafergear.com](http://www.schafergear.com)

**Smalley Steel Ring Co.**

Page 21  
[www.smalley.com](http://www.smalley.com)

**Stock Drive Products/Sterling Instrument**

Back Cover  
[www.sdp-si.com/e-store](http://www.sdp-si.com/e-store)

**Suhner Manufacturing Inc.**

Page 2  
[www.suhner.com](http://www.suhner.com)





**Ground Gear Manufacturing**

**GEAR MOTIONS, INC.**  
An Employee Owned Company

Learn about one of the most modern fleets of Gear Grinders, including the Höfler 700 and Gleason Tag 400 at ISO 9001:2008 registered Oliver Gear. See the latest Reishauer and Kapp Gear Grinding technology, at ISO 9001:2008 registered Nixon Gear, as well as the latest in CNC Gear Hobbing and cellular manufacturing.

PH: (315) 488-0100  
ron.wright@gearmotions.com  
www.gearmotions.com



**THE Gear Works**  
Ingenuity in Motion™

Gearbox Repair  
Gear Metrology  
Gear Grinding to 2600 mm  
Industrial Gears  
Custom Gearboxes  
Turbo Compressor Gears  
Machining  
Emergency Service  
ISO 9001 Certified

Seattle, Washington | 206.762.3333  
www.thegearworks.com

The Power Transmission

# Buyers Guide

At  
www.powertransmission.com

- ⚙ Gears
- ⚙ Bearings
- ⚙ Motors
- ⚙ Gear Drives
- ⚙ Couplings Equipment
- ⚙ Motion Control

...and everything else you need to make things move.

Contact hundreds of the industry's leading suppliers, quickly and easily, all in one place.

www.  
**powertransmission**.com

**72%** of gear manufacturers saw sales increases in 2011

**88%** indicated they are optimistic about their ability to compete over the next five years.

[Source - Gear Technology - State of the Industry Survey - Nov/Dec 2011]

There is no better time than now to market for new and more profitable customers.

Power Transmission Engineering is read by the individuals that buy and/or specify gears. Advertise where your current and future customers will see it:

**Power Transmission Engineering &**  
**www.PowerTransmission.com**



For more information scan the QR Code or call Dave Friedman at 847-437-6604.

**Gear Manufacturers increase profits with advertising in PTE!**



**Power Transmission Engineering**  
October 2011  
**BACK TO BASICS**  
WHEN A GOOD GEAR DRIVE SYSTEM GOES BAD  
BEARING SELECTION GUIDE  
Technical [Selecting and Sizing Ball Screw Drives] [Gallium Nitride Inverter Drives Motors More Efficiently]  
Case Study New Conveyor Drives Industrial Distribution  
Power Play Fingerboarding??  
www.powertransmission.com

# The Skating Life

SMB Bearing Offers Unique Solutions for NorthwoodsFB

There's skateboarding and then there's SKATEBOARDING. The difference simply comes down to passion and desire. Some skaters attempt the occasional trick on a park bench, half-pipe or empty swimming pool. SKATERS eat, drink and sleep skateboarding. When they're not skating, they're working out in their heads what they need to do to expand and promote their sport. How else could you explain the phenomenon known as fingerboarding?

"Fingerboards are small skateboards one can ride using their index and middle finger as legs and feet. Every trick that can be done on a skateboard can also be performed on a fingerboard," said Jared Hadden, owner and operator of NorthwoodsFB. "Fingerboarding is perfect for rainy days, challenging yourself, sharpening your focus, developing muscle memory and improving hand-eye coordination. What is often misunderstood as a toy is really a tool for precision art-of-movement and by all definitions—a sport." Hadden first became involved in fingerboarding around 1986, when he and his brother started making small skateboards out of index cards.

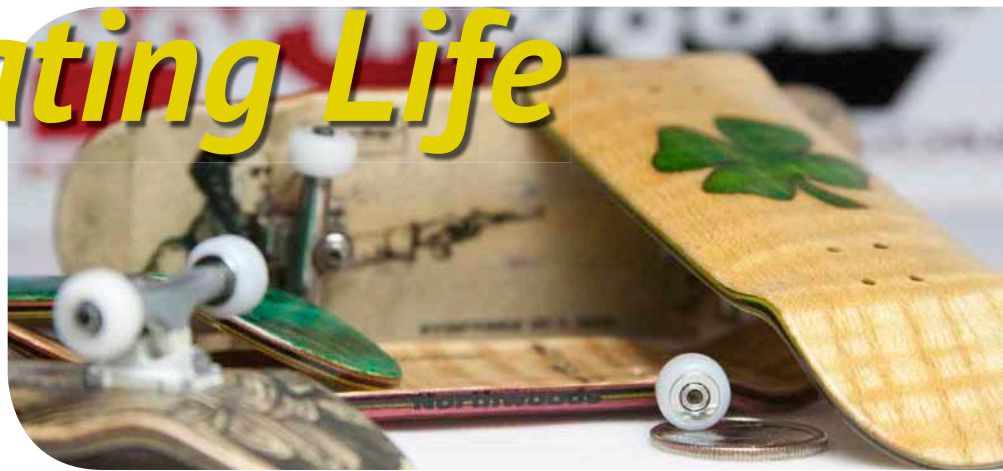

"Taping a graphic torn from a *Thrasher* ad (*Ed.'s Note: for those of a certain age, a popular skateboarding magazine*), wheels and a thin metal axle from Hot Wheels brought countless hours of joy. Shortly after this time the clear plastic skateboard key chain was introduced followed by the household name TechDeck ([www.techdeck.com](http://www.techdeck.com)) a few years after that." 20 years and 200+ TechDeck's later, Hadden had the desire to solve all the problems he had ever encountered in the design of fingerboards. His basic intention was to design fingerboarding equipment that met his own lofty expectations for the sport. Thus, NorthwoodsFB was born ([www.northwoodsfb.com](http://www.northwoodsfb.com)).

"This serious approach is what I felt was lacking in the products out at that time. I wanted to take it further by considering the needs of the fingers, not the feet and solve the long running problems I had with the gear that was available," Hadden said.

Gear that included reworking the trucks, wheels and bearings to make them more like their full-size skateboard counterparts. "I demanded a strong, smooth rolling wheel and bearing that can take repeated impacts," Hadden said. During his research to design a better fingerboard, he contacted SMB Bearings ([www.smbbearings.com](http://www.smbbearings.com)), a U.K. bearing specialist known for unique miniature applications.

"We like to support our customers where we can, sponsoring them with bearings and publicity for their hobbies, passions and pastimes," says Emma Hoskisson, sales and marketing administrator at SMB. "These bearings are often used in bespoke, high-end applications, limited only by the customers' imagination."

It was no surprise that Hadden's imagination—and a knack for using *Solidworks*—helped create a new concept for fingerboards. "I designed a dual-bearing wheel that prevents wheel damage from trucks and disperses the side impact from the center to a much larger area of the wheel."

The results of Hadden's design, coupled with SMB's micro bearings, have produced a wheel that will take tremendous abuse and still perform perfectly every time. With the right deck and equipment in hand, Hadden can now concentrate on promoting his sport through learning workshops, dedicated events or just teaching kids how to ride.

"My main mission is to grow the sport of fingerboarding by giving it the respect and consideration it deserves. I personally owe my best efforts to fingerboarding for all the pure and private joy it has brought me throughout my life." **PTE**



Jared Hadden performs an ollie nose-grind, nollie-flip out using his fingerboard (courtesy of NorthwoodsFB).

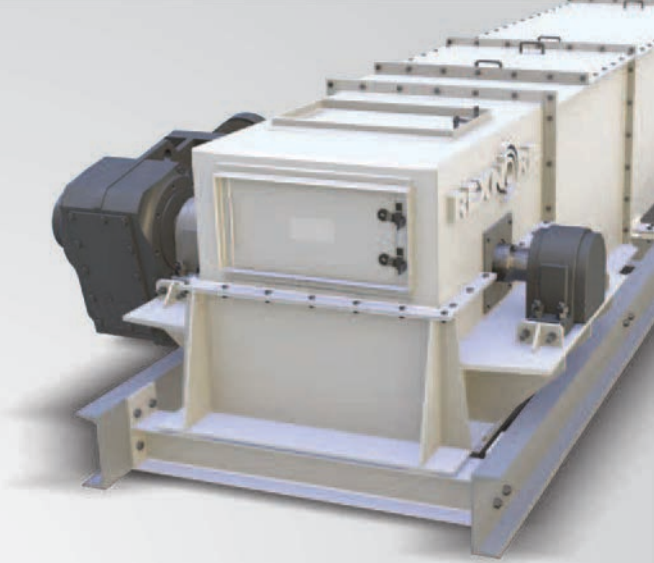

# Solutions you can trust.

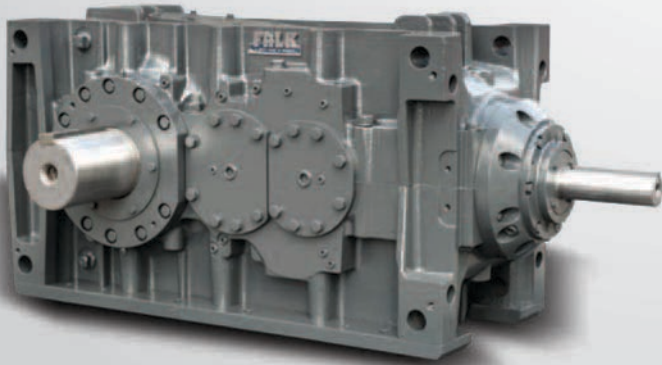
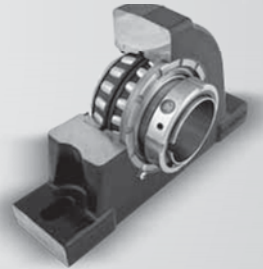

## Brands you can trust.

Rex®    Falk®    Link-Belt®    Thomas®    TableTop®    MatTop®    Marbett®    RTS®

Rexnord solutions are not just about a transaction. To support your business, Rexnord delivers what's needed to run a successful operation, including:

- Dependable product availability and on-time delivery
- Innovative solutions for a broad range of applications
- Respected brands supported by sales, training and technical expertise

Rexnord provides a comprehensive line of products and services:

- Bearing
- Coupling
- Gear
- Industrial Chain
- Conveying Equipment
- FlatTop
- Installation, testing, maintenance and repair

# SMALL DRIVE COMPONENTS

## All From One Source

130,000 off-the-shelf standard components

For over fifty years SDP/SI has been providing precision components and system solutions for industrial, medical, defense and aerospace applications.

### Assemblies

Gearheads / Speed Reducers  
Differentials  
Anti-Backlash Assemblies  
Clutches

### Gears and Racks

200 DP to 12 DP and  
0.25 Module to 3.0 Module  
AGMA tolerancing to Q14

### Worms and Worm Wheels

72 DP to 16 DP

### Timing Belt Pulleys

Metal and molded  
1 mm Pitch to 10 mm Pitch

### Timing Belts

Large inventory of  
urethane and neoprene materials

### Our knowledgeable engineering staff can assist you in every step.

- + Custom designed components and assemblies
- + Reverse engineering
- + Product support from prototypes  
to large production runs
- + Cost-effective solutions

At SDP/SI you'll find the right mix for setting ideas into motion: experience, state-of-the-art manufacturing facility, superior design capabilities and the very best people running it all. Call us today and see what we can do for you!

# SDP/SI

STOCK DRIVE PRODUCTS/STERLING INSTRUMENT

New Hyde Park, New York  
800-819-8900

[www.sdp-si.com](http://www.sdp-si.com)

[sdp-sisupport@sdp-si.com](mailto:sdp-sisupport@sdp-si.com)

Internal Gear C,  $z_c$

Planet Gear B,  $z_b$

Carrier D

Sun Gear



**Stock Drive Products: ISO 9001 Registered**  
**Sterling Instrument: ISO 9001 and AS9100C Registered**