

Power Transmission Engineering®

MARCH 2017

ENGINEERING SHOWCASE 2017

MOTION CONTROL

WHY DIRECT DRIVE?
SAVING TIME WITH AUTO-TUNING DRIVES

PLUS

MEDICAL DEVICES
MOTOR BASICS
BEARING LIFE MODELING
AND MORE...

A cyclist wearing a white shirt, blue shorts, and a helmet is riding a bicycle on a rocky mountain peak. The background shows a vast, hazy mountain range under a soft, golden sky, suggesting a sunrise or sunset.

Peak performance

Take gearbox reliability to a higher level with SKF.

SKF is helping both manufacturers and end users optimize industrial transmission performance. Solutions ranging from upgraded SKF Explorer spherical roller bearings to automatic lubrication systems can enable reduced friction, increased torque and lower energy use, all while increasing bearing service life and extending maintenance intervals. When needed, complete gearbox remanufacturing services from SKF can return gearboxes to like-new condition.

For more information, visit [skf.com](https://www.skf.com).

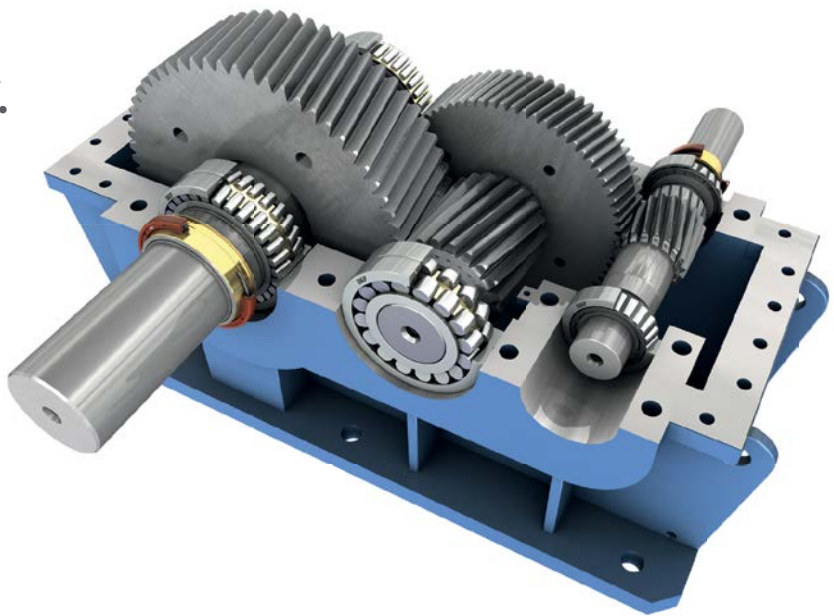

SKF®

Power Transmission Engineering®

MARCH 2017



[52]

Engineering Showcase 2017

FEATURE ARTICLES

- [20] **Why Direct Drive?**
The basics of how they work and when to use them.
- [24] **Saving Time with Auto-Tuning Drives**
Auto-tuning drive software is becoming more sophisticated than ever, making it easier than ever to save time in the face of talent shortages.
- [28] **Devising New Devices**
Medical device industry continues to grow and innovate.
- [52] **Engineering Showcase 2017**
This special section highlights some of the industry's leading suppliers.

TECHNICAL ARTICLES

- [34] **Ask the Expert**
ISO/AGMA Standards — Specific Sliding Defined.
- [36] **A Major Step Forward in Life Modeling**
Innovative, new bearing rating life model presented.
- [42] **Baldor Basics: Motors**
Motor temperature ratings, and metric motors.
- [48] **Copper in Motor Repair Facilities**
Repair versus replace decisions at motor repair facilities.

Vol. 11, No. 2. POWER TRANSMISSION ENGINEERING (ISSN 2331-2483) is published monthly except in January, May, July and November by Randall Publications LLC, 1840 Jarvis Ave., Elk Grove Village, IL 60007, (847) 437-6604. Cover price \$7.00. U.S. Periodicals Postage Paid at Elk Grove Village IL and at additional mailing offices. Send address changes to POWER TRANSMISSION ENGINEERING, 1840 Jarvis Ave., Elk Grove Village, IL 60007.

Randall Publications LLC makes every effort to ensure that the processes described in POWER TRANSMISSION ENGINEERING conform to sound engineering practice. Neither the authors nor the publisher can be held responsible for injuries sustained while following the procedures described. Postmaster: Send address changes to POWER TRANSMISSION ENGINEERING, 1840 Jarvis Avenue, Elk Grove Village, IL, 60007. ©2017 Contents copyrighted by RANDALL PUBLICATIONS, LLC. No part of this publication may be reproduced or transmitted in any form or by any means, electronic or mechanical, including photocopying, recording, or by any information storage and retrieval system, without permission in writing from the publisher. Contents of ads are subject to Publisher's approval.

Power Transmission Engineering

VOL. 11, NO. 2



Flexible shafts for special machinery

Efficient automation starts with efficient shafts.



SUHNER MANUFACTURING, INC.
 Rome, GA 30161
 706-235-8046
www.suhner.com
info.usa@suhner.com

SUHNER
 EXPERTS. SINCE 1914.

[04] **PTEExtras**

Check us out — www.powertransmission.com — for latest videos, blog postings, social media and events

[06] **Publisher's Page**

Showing Up Is Half the Battle.

[08] **Product News**

Servo drives, bearings, motors and much more

[32] **Engineering sMART**

Products and services marketplace

[60] **Industry News**

News and names worth noting

[64] **Events**

Setting Sights on Hannover Messe 2017.
 Automate 2017 Highlights Solution Providers and Integrators.

[68] **Calendar**

April 24-28: Hannover Messe 2017, Hannover, Germany;

May 2-4: AGMA 2017 Gearbox System Design, Clearwater Beach, Florida;

May 24: Smart Manufacturing: Digital Transformation, Nashville, Tennessee.

[70] **Advertiser Index**

How and where to reach every supplier in this issue.

[71] **Subscriptions**

Free subscriptions, anywhere in the world.

[72] **Power Play**

Your Robotic Chariot Awaits

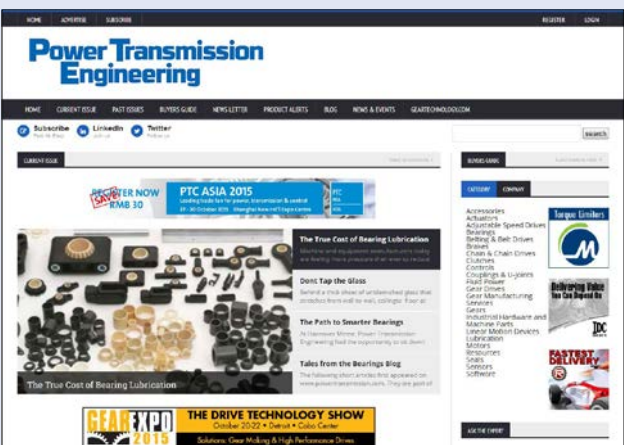

Power Transmission Engineering

- Technical content free for everyone
- Comprehensive Buyers Guide
- The latest news

www.powertransmission.com



Stock and Custom Mechanical Components One Convenient Source



Custom Design, Engineering & Manufacturing • Timing Belts and Pulleys
Precision Gears & Gearboxes • Precision Machined Components
Molded Components • Mechanical Assemblies

REGISTERED
ISO 9001
AS 9100

USA Manufacturer • Est. 1950



We Provide Total Motion Control Solutions
Design ▶ Engineer ▶ Manufacture ▶ Assemble
Ship Complete Subassemblies for a Wide Variety of
Product Applications.

SETTING IDEAS INTO MOTION

SDP/SI

STOCK DRIVE PRODUCTS/STERLING INSTRUMENT

Designatronics Inc.

Call our Engineers for a Design Consultation and Place Your Order Today.
Phone: (800) 819-8900 Fax: (516) 326-8827 www.sdp-si.com

PTE Videos

Counterfeit bearings with a total weight of 15 tons and a market value of approximately 1,000,000 euros were destroyed in Greece. The bearings were seized as part of a raid at a dealer's warehouse in the area of Piraeus, with whom SKF had no business relationship. Check out the video here:

www.powertransmission.com/videos/



Event Spotlight: Hannover Messe 2017

Get all your Hannover news, previews and show information on our homepage, social media sites and in the pages of this magazine (See page 64). Hannover Messe will examine Industry 4.0, integrated energy, digital twins, predictive maintenance, digital energy, networked and collaborative robots (cobots) and more. Visit www.powertransmission.com for all the details.

Bearings With Norm

After a successful 2016 in the automotive industry, our resident bearing expert Norm Parker warns readers to hold suppliers accountable in the blog entry *Avoiding Bearings "Made in Wherever."*

www.powertransmission.com/blog/avoiding-bearings-made-in-wherever/

Ask the Expert

Do you have a question about gears, bearings, motors, clutches, couplings or other mechanical power transmission or motion control components? Submit your question at the link below, and we will forward it to our panel of experts.

www.powertransmission.com/asktheexpert.php

Stay Connected



Follow us on Twitter
twitter.com/#!/PowerTransMag



Connect with us on LinkedIn
www.linkedin.com/groups/Power-Transmission-Engineering-PTE-2950055



Subscribe Online
www.powertransmission.com/subscribe.htm

Power Transmission Engineering

Randall Publications LLC

1840 Jarvis Avenue
Elk Grove Village, IL 60007
Phone: (847) 437-6604
Fax: (847) 437-6618

EDITORIAL

Publisher & Editor-in-Chief

Michael Goldstein
publisher@powertransmission.com

Managing Editor & Associate Publisher

Randy Stott
wrs@powertransmission.com

Senior Editor

Jack McGuinn
jmcguinn@powertransmission.com

Senior Editor

Matthew Jaster
mjaster@powertransmission.com

News Editor

Alex Cannella
alex@garttechnology.com

Editorial Consultant

Paul R. Goldstein

ART

Art Director

David Ropinski
dropski@powertransmission.com

ADVERTISING

Advertising Sales Manager & Associate Publisher

Dave Friedman
dave@powertransmission.com

China Sales Agent

Eric Wu
Eastco Industry Co., Ltd.
Tel: (86)(21) 52305107
Fax: (86)(21) 52305106
Cell: (86) 13817160576
eric.wu@eastcotec.com

Materials Coordinator

Dorothy Fiandaca
dee@randallpublications.com

CIRCULATION

Circulation Manager

Carol Tratar
subscribe@powertransmission.com

Circulation Coordinator

Barbara Novak
bnovak@powertransmission.com

RANDALL PUBLICATIONS STAFF

President

Michael Goldstein

Accounting

Luann Harold





OFFSET SHAFTS. SOLVED.

Offset Couplings from Zero-Max reduce space requirements for parallel offset shafts in large system applications. These specialized couplings provide machine designers with an important option for reducing overall machine size and footprint.

Compact in design, Schmidt Offset Couplings transmit constant angular velocity and torque in a wide range of parallel shaft misalignments. Handling high amounts of parallel offset up to 9 inches, they are available with torque capacities up to 459,000 in-lbs.

Schmidt Offset Couplings can be mounted to shaft hubs or directly to existing machine flanges. They are available for shaft displacements of 0.156 inches to 17.29 inches and torque capacities from 55 to 459,000 inch-pounds. Many design configurations are available including specials.



www.zero-max.com 800.533.1731

////// ZERO-MAX®

Showing Up is Half the Battle

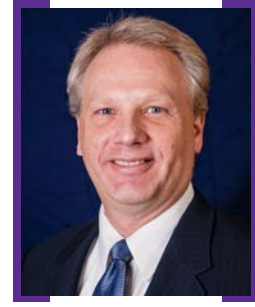

For the past several months, I've been sneaking away from work early every Thursday afternoon to coach my daughter's Science Olympiad team.

Those of you who read this column regularly know that I'm a supporter of STEM education programs, and I've encouraged you to participate in those programs wherever possible. You may also remember my daughter Renee, who has participated in a number of STEM-related events and activities over the past several years.

Science Olympiad is an academic competition with regional, state and national contests. Each school assembles a team of students who have to tackle a wide variety of science-related topics. Some of the events are strictly knowledge-based, while others are more engineering-oriented, project-building events.

Renee, an eighth grader, is on the team for her middle school, and I volunteered this year to help coach her and several other students for one of the events. In my case, that event was Anatomy & Physiology.

I know what you're thinking. He's not a doctor. He never went to medical school. What does he know about anatomy? I was thinking pretty much the same thing several months ago. It's what most parents would probably think. But it doesn't matter. I realized very quickly that my job wasn't to be a teacher. It was to be a guide.

When your kids are little, you can teach them about anything, because in the beginning, you know more than they do about every possible subject. But that changes as they get older and smarter. They learn about things you never knew, and they become interested in subjects you never even thought about. While it may seem scary when you realize they've become smarter than you, it's also a joy to see them grow.

I had no illusions about being an expert in this subject area. So mostly what I did was find resources for them to use and help them get organized. I narrowed things down and pointed them in the right direction. I compiled practice tests so they would have a better idea what they needed to know.

Sure, I wish I had more knowledge to share. And truth be told, I wish I could have done a lot more coaching. Now that we're on the eve of their regional competition, I feel like I didn't do enough to help prepare them.

But at least I showed up, and I'm pretty sure that's made a difference.

This morning, when I got in the car to drive Renee to school, I noticed that she had a stack of index cards among her school things. I figured they were for one of her classes, but when she had to run back in the house because she forgot something, I picked up the stack and flipped through them. It turned out that they were flashcards, and they were full of information about the nervous system, sensory organs and the endocrine system—Renee's Science Olympiad subjects. More importantly, I recognized most of the content on the flashcards as having come from the practice tests I had prepared.

Renee has always been academically self-motivated. She likes learning things. So I can't really claim any credit for her desire to be prepared. I never even suggested that she should study or make flashcards. She did that on her own. But I wonder how invested she would have been in the whole thing if I weren't involved, too. While I'm confident she would have done her best no matter what, I'm also confident that my participation hasn't hurt, either.

We hear all the time about how important STEM education is, especially in industries like ours. But hearing about it is one thing. Doing something is another. It doesn't take much. The hardest part is just showing up.

So once again I encourage you to do whatever you can to foster interest and enthusiasm for STEM subjects in whatever young people you encounter. Maybe you can even find a worthy excuse to leave work early.

A handwritten signature in black ink that reads "Randy Stott". The signature is written in a cursive, flowing style.



Non-stop power

Presenting Brother Premium Efficiency Gearmotors.

What sets Brother Gearmotors apart:

Quality

- Control over all major manufacturing processes
- Manufacturer of our own motors, housing, gearing and shafts
- High-quality paint assures water-tight and chemically resistant units

Responsiveness

- Faster deliveries with 3-5-day average lead time on orders
- Dedicated, US hub for enhanced support
- Emergency same day or 24-hour service available

Product Features and Flexibility

- Compact, sealed for life and light weight in size
- Multiple standard specifications, options and mounting positions
- 1-3 horsepower gearmotors compliant with the new government high efficiency requirements for small electric motors



brother
at your side

866.523.6283
BrotherGearmotors.com

Lubrication Scientifics

OFFERS FLEXIBLE, MODULAR DUAL-LINE LUBRICATION SYSTEM

The costs of bearing failure continue to plague heavy industrial plants, including steel and metals mills, particularly in rolling mills, multi-roll cluster mills, wire and rod mills and continuous casting operations.

Frequently these costs are a consequence of the failure to verify that bearings are receiving the proper amounts and types of lube oil or grease via the integration of monitoring capabilities into large, automated lubrication systems.

Without proper lubrication bearings seldom survive more than 5-10 percent of their potential service life. This is due to multiple factors, among which corrosion, heat, caustic elements and high shock loads are major players. However, according to Richard Hanley, president of Lubrication Scientifics (Irvine, CA), failure to properly lubricate production equipment, particularly at the critical points, can be an even greater cause of bearing failure, resulting in unnecessary downtime and replacement costs.

Lubrication Scientifics engineers and manufactures a variety of automated lubrication systems and components that are installed on equipment used in a wide variety of applications in industries including steel, pulp & paper, petrochemicals and mining.

The critical points Hanley refers to include those bearing points that, if not provided the appropriate lubricant at necessary intervals, will cause the most extensive damage to equipment or present risks to plant personnel.

“You can’t be sure that you are lubricating all of those points successfully unless you have consistently accurate monitoring, or verification, that the lubricant is dispensed through the pump to the point where it should be injected — at proper intervals,” Hanley said.

Yet, the large investments required to install and maintain lubrication systems with monitoring capabilities — often \$500,000 or more - discourages steel and metals processing plants from doing so. Or, if they are installed, they often require frequent and expensive repair or replacement.

The conventional approach

The traditional methodology for heavy industrial lubricating applications is the conventional dual-line lubrication system. Capable of delivering varied amounts of lubricant, this type of automated system is ideal for lubricating thousands of points over long distances, with lube oil or grease output being controlled individually at each point. Also important, a single blockage will not shut down the entire system.

Yet, there are drawbacks to this standard dual-line system. Because it is composed of multiple one-piece lubrication dispensing blocks (each ser-

A modular alternative

To dramatically reduce those monitoring investments and simultaneously reduce bearing maintenance and replacement costs, Lubrication Scientifics has introduced a new design in dual-line lubrication systems, one that can continuously lubricate and monitor critical equipment bearing points over long distances. The new system, known as the MDL-50 Series, is a modular design with lower investment costs and higher system sustainability.

Because of its modular design, the MDL-50 retains all of the benefits of standard dual-line systems; the MDL

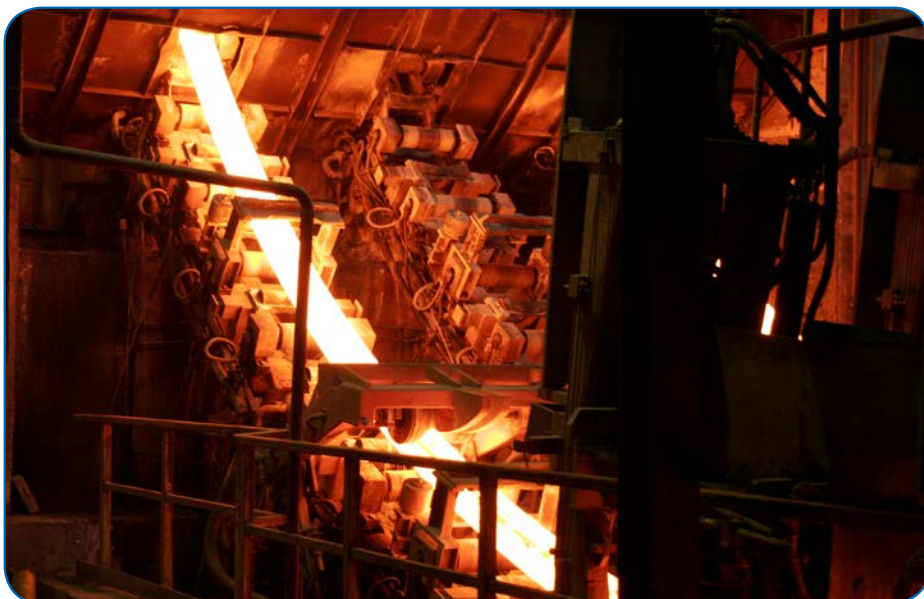

vicing up to eight points), whenever a single lube point fails, the entire block must be replaced, resulting in added time and labor to the cost of a replacement block. But even more significant to many applications, critical point monitoring, or verification, is very expensive with standard dual line systems.

“In heavy industrial application such as steel mills and metalworking plants, the cost of critical point monitoring has become a key issue,” Hanley says. “In large systems, it can cost thousands of dollars to monitor a single bearing point.”

series offers several additional features that dramatically reduce lifetime maintenance costs. For example, it is never necessary to disconnect MDL supply or discharge valves to change out a non-working section. When valve replacement is required, only the piston section — rather than the entire valve block — is replaced, a job that takes only about two minutes instead of two hours.

In order to meet the largest lubrication system requirements, the MDL-50 system design also permits the creation of dual-line valves with an infinite number of outlets, making this technology ideal for the automated lubrication of equipment used in the

steel, cement, pulp and paper, mining and other heavy industries.

“Essentially, the user can tap into the dual lines anywhere and insert a dual-line valve, a capability that enables and the grouping of critical lubrication points into zones,” Hanley explains. “Creating zones enables system designers to economize on monitoring hardware. In effect, this provides systems design options that have never before been available.”

The new modular system is available in both carbon steel and 316 stainless steel for use in highly caustic environments, including those that are washed down with caustic solutions.

Plus, the MDL-50 series provides the flexibility of a “hybrid” system because it can be easily converted to dispense either grease or oil without having to abandon the original investment in dual-line components.

Long-term benefits, short-term payback

Hanley says that conventional dual-line systems with monitoring capa-

bilities cost users in excess of \$100 per point to incorporate monitoring hardware, plus installation expenses.

“Using the new modular dual-line approach with critical points grouped in zones, users can monitor everything tied to that valve, up to 360 points, for less than \$1,000,” Hanley says.

He adds that, with modular dual-line systems dispensing grease, significant reduction of lubricant usage is required — sometimes a reduction of 90 percent. “This not only saves on grease costs but also virtually eliminates the high costs of grease disposal.”

Hanley adds that while the savings of lube oil will not be as great as that of grease, ensuring that a constant supply of clean oil in the required amount and intervals will also greatly im-

prove on bearing life, which is the biggest payoff of the modular system.

For more information:
Lubrication Scientifics, LLC.
Phone: (877) 452-0157
www.lubricationscientifics.com

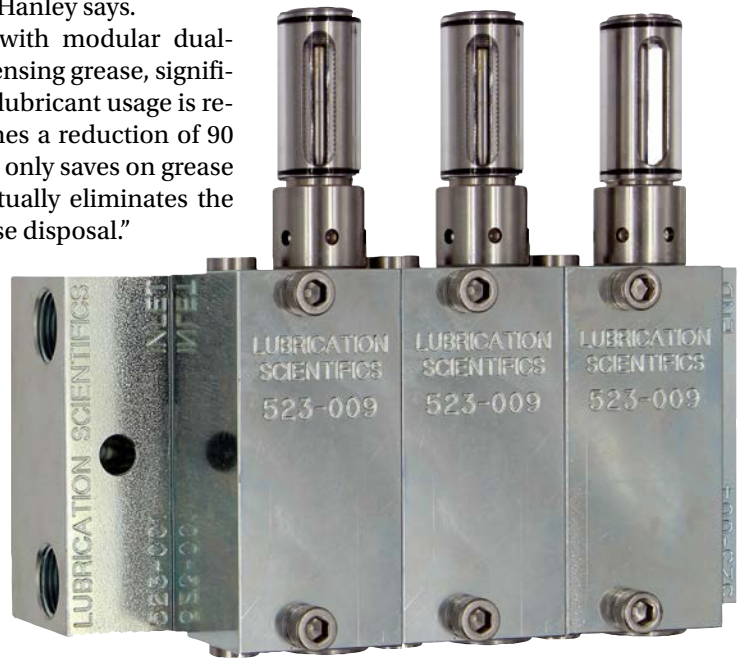

DieQua offers more gearboxes

Are You Selecting The Right Technology?

Whether your application is for precise motion control or for general power transmission, there are several gear technologies that can do the job. But which one does it best?

Only DieQua offers the widest range of gearmotors, speed reducers and servo gearheads along with the experience and expertise to help you select the optimal solution to satisfy your needs.

If you are using gearboxes, you should be talking to DieQua!

DIEQUA
Corporation
www.diequa.com 630-980-1133

Power Transmission Solutions

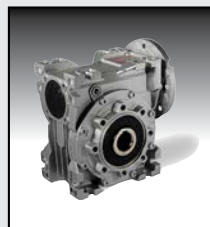

Worm Reducers

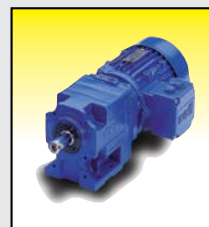

Helical Gearmotors



Spiral Bevel Gearboxes

Motion Control Solutions



Planetary Gearheads

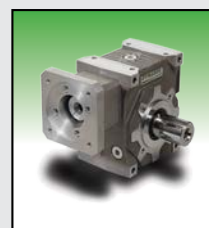

Servo Worm Gearheads



Precision Cycloidals



Quality Solutions Since 1960

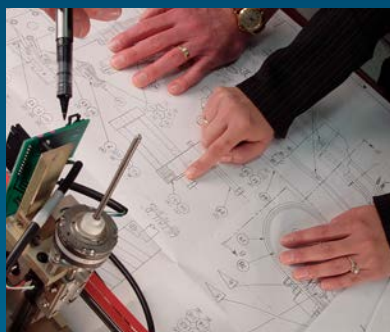

- Standard Components
- Made to Print Parts & Assemblies
- Design & Engineering

Nordex.com

sales@nordex.com
eng@nordex.com

Phone: (800) 243-0986
or Call: (203) 775-4877

Nexen Group

INTRODUCES COMPLETE GEARED BEARING SOLUTION

Nexen Group, Inc. has introduced a complete Geared Bearing solution based on their innovative Roller Pinion System (RPS). The new Geared Bearing package comes complete with a zero backlash gear mounted and dialed in on a precision grade high capacity bearing. Nexen's Geared Bearings are available in a wide variety of sizes and gear ratios, and preconfigured for fit, form and function, for easy integration into any precision rotary motion application.

Nexen's new Geared Bearing Product Selector tool makes it quick and easy to select the gear needed. Customers simply adjust online sliders for torque, gear O.D. size, accuracy and gear ratio requirements. The tool instantly shows all the options that fit. OEMs also have easy access to STEP files and specifications. Nexen holds bearings in inventory and gear raw material on hand, so bearings are available for fast delivery.

For more information:

Nexen Group
Phone: (800) 843-7445
www.nexengroup.com



AutomationDirect

EXPANDS AC MOTOR LINE

AutomationDirect's IronHorse line of general purpose three-phase motors now includes the MTRP-series 56HC-frame premium efficiency motors available from 1 hp to 3 hp. The rolled steel motors are available in 1,800 and 3,600 rpm models and feature 4:1 constant torque and 10:1 variable torque speed ranges, TEFC frames, cast aluminum end bells and removable mounting bases. MTRP-series motors start at \$142.00, meet RoHS and low voltage directives and are CSA and EU approved; available accessories include bases, junction boxes, fans and fan shrouds.

For more information:

AutomationDirect
Phone: (800) 633-0405
www.automationdirect.com



Kollmorgen

SERVO DRIVE SYSTEM REDUCES OEM COSTS

Kollmorgen offers the AKD-N Decentralized Servo System, which reduces costs for OEMs while increasing machine effectiveness and design flexibility. Robust construction in protection class IP67 eliminates the need for protective enclosures, allowing for a smaller and more easily integrated switch cabinet. Because of its size, durability, and IP67 rating, the AKD-N can be mounted in the immediate vicinity of the motor. The patented design also allows for substantial cable reduction: The power supply, safety and fieldbus communication are combined in a single cable of only 11 mm, saving machine builders significant control panel space, weight and the related expense.

(On the motor side, only one cable is needed for power, brake control and feedback—machine builders can save more than 80 percent in cabling.) The AKD-N's simple connection technology saves time on assembly, installation and start-up, while the integrated DC connection saves energy during operation. Faster cleaning cycles allow maintenance and service tasks to be completed more quickly.

For more information:

Kollmorgen
Phone: (540) 633-3545
www.kollmorgen.com



EK

THE COUPLING. SIMPLY
UNBEATABLE 2-25,000 NM.

Schaffner

MOTOR DRIVES IMPROVE
PERFORMANCE

Schaffner introduces the FN510 dv/dt filter which eliminates premature motor damage caused by high dv/dt, over-voltages on motor cables, motor overheating and more, to prolong service life motors in high precision environments. Suitable for motors from 1.5 to 30 Kw with frequencies up to 400 Hz (4 to 24A) or to 200 Hz (33 to 66A), this proven technology reduces high output voltage dv/dt from IGBT motor drives and restricts over-voltages caused by line reflections on motor cables. In addition to providing efficient motor and insulation protection, the FN510 includes an IP20 housing and touch-safe terminal blocks which contribute to overall equipment safety. Typical applications include servo drives, closed loop vector drives, machinery with servo or torque motors, robotics, pick-and-place machinery, motors with short to medium cables, and applications where sine wave filters are not applicable.



WWW.RW-AMERICA.COM

R+W
A POPPE + POTTHOFF COMPANY



EXPANDING YOUR EXPECTATIONS

McInnes Rolled Rings continues to expand not only our facility, but also your expectations of what responsive service should be. We're committed to the delivery of quality products with the fastest shipping times in the industry.

Speed. Quality.
McInnes Rolled Rings.

McINNES
ROLLED RINGS

1.800.569.1420
1533 E 12TH STREET • ERIE, PA 16511
www.McInnesRolledRings.com

Temperature monitoring and an internal cooling fan protect the filter from thermal overload. The FN510 eliminates the interference propagation towards components or conductors in the vicinity. They are easily installed and provide immediate results. Models are available to accommodate switching frequencies of 2 to 16 kHz. Meets UL 1283, CSA 22.2 No. 8 1986, IEC/EN 60939.

Schaffner FN510 filters are part of an extensive family of dv/dt filters and sine wave filters which improve motor-drive performance for applications where long cable lengths are a concern, even up to 690 vac.

For more information:
Schaffner EMC
Phone: (800) 367-5566 ext. 276
www.schaffnerusa.com



Warner Linear

STEERS UNMANNED VESSEL DESIGN

Research and development into unmanned vehicles has made considerable progress in the past few years. Designing fully autonomous vehicles presents additional challenges since they need to share operational space with human-operated vehicles. In an effort to advance the technology for marine surface vessels, a biennial competition is being held for univer-

sities to showcase their expertise; an endeavor that has been supported by Warner Linear.

The development of autonomous marine vessels and the technology required to operate them will bring significant benefits to applications in search and rescue, shipping security, environmental monitoring and marine science. Incorporating the latest technology and cutting edge software for the sensor systems with precise and reliable propulsion and steering arrangements will soon bring benefits to a number of applications.

15 university teams from five Pacific Rim countries, Australia, Japan, South Korea, Singapore and the USA, were set the challenge to design and build a highly capable unmanned surface vessel (USV)



to complete against each other in the Maritime RobotX Challenge (MRC), held in Singapore.

One group of undergraduate and postgraduate students from the University of Newcastle in Australia, was chosen to take part in the competition and needed some assistance with the steering system of their USV. The challenge led them to Warner Linear, part of the Altra Industrial Motion Group, and a leading manufacturer of rugged service electro-mechanical actuators.

Each team was provided with a 16-foot (5 meter) Wave Adaptive Modular Vessel (WAM-V) that needed to be equipped with propulsion, guidance and sensors that would enable it to complete a set of predetermined tasks. Each challenge, which included detection and avoidance of obstacles, as well as an underwater search for an acoustic source, was designed to test the design and implementation of the sensors and control systems.

One of the more basic elements of the design are the propulsion and steering systems that have to be integrated with the vision and guidance systems so that the vessel can avoid obstacles. The team from Newcastle chose to design a linkage that turned the electric outboard motors using linear actuators.

Following some initial research, the designers contacted Warner Linear to discuss the challenge and find a solution. Based on the team's design requirements, Warner engineers configured two identical K2x ball screw linear actuators, which operate at 24 VDC, with a 2,800 lbs (1,270 kg) load capacity. The 12" (300mm) stroke and 5:1 gear ratio offered the required speed and torque to provide fast and accurate steering control, while the position feedback would provide the necessary information for the guidance software.

Nicolas Weightman, student team leader - hull mechanical and electrical comments: "While we didn't win the competition, the pair of donated Warner Linear actuators definitely gave us the advantage of being able to outmaneuver most of the other teams. We wouldn't have been able to run such a steering system without their help."

The high quality K2x linear actuators

are from Warner's B-track range. They have been designed for use in tough, high-load applications where they will be in frequent use. The ball screw actuators are designed to provide years of trouble-free service in harsh, marine environments. They feature integral o-ring seals, bi-directional holding brakes and Nitrotec treated end fittings for superior strength and corrosion resistance.



Models also feature heavy-duty, sealed double ball bearing motors and

a mechanical torque limiter for end-of-stroke and overload protection. High performance, synthetic, lifetime lubrication is used throughout, while unique, patented screw-end bearing guides provide smooth extension operation, high side-load capability and aids screw re-lubrication.













For more information:

Warner Linear
Phone: (800) 825-6544
www.warnerlinear.com

Servo-Gearheads

**For all YOUR automation-, robotics-, precise motion- APP's
.....we have the reliable gearbox solution**

 PLE	 WPLE	 PLFE	 WPLFE
 PLPE	 WPLPE	 PLHE	 HLAE <i>stainless</i> NEW
 PLN	 PLFN	 PSN	 PSFN <i>helical</i> NEW

Contact us:
Tel: 980-299-9800
14325 South Lakes Drive,
Charlotte, NC 28273

www.neugartusa.com



Smalley

EXPANDS WAVE SPRING SERIES

The question you are asking should not be how many miles did I ride or how many steps did I take, but “how did someone make a wave spring that small?” As engineers around the world design smaller and smaller assemblies, the question becomes, where can I find the compact components to support my designs?

Smalley has the answer with its newly expanded Crest-to-Crest Wave Spring Series. Smalley’s popular C (imperial) and CM (metric) Series have been expanded; standard sizes are now available from stock down to .188” and 5 mm in diameter.

“Smalley was the originator of the Crest-to-Crest Wave Spring,” states Darryl McBride, Smalley’s director of engineering. “I was amazed when I saw our springs coiled up to 12 feet in diameter. What surprised me even more was how much engineering went into designing smaller springs. Our expanded spring series will open up possibilities for designers in the medical, computer and robotics industries, where wave springs couldn’t fit before,” states McBride.

For more information:

Smalley Steel Rind Co.
Phone: (847) 719-5900
www.smalley.com

Fuji Electric Corp.

EXPANDS VFD SERIES

Fuji Electric Corp. of America has announced that they have expanded their portfolio of variable frequency drives with the addition of FRENIC-Ace, a full-featured, versatile drive with advanced integration capabilities including applied power ratings, sensorless dynamic torque vector control, PM synchronous motor control, 2-channel on-board RS485 communication port and customer customizable logic.

“Flexibility was the main objective with the FRENIC-Ace, and this series, designed for the varying needs of OEMs, integrates easily into a wide variety of equipment and processes,” said David Schrader, general manager of Fuji Electric Corp. of America’s Drives and HMI Departments. “Today’s customer is focused on reduced operational costs and lower total costs of ownership, and FRENIC-Ace delivers on those demands.”

The FRENIC-Ace, which will be available for shipment in April, is the latest

innovation from the electronics manufacturer as they continue to expand their portfolio of variable frequency drives for the Americas. All models in the new series come standard with an industry-leading three-year warranty, and customers will now have the ability to use an optional keypad with LCD display or a keypad equipped with a USB port for convenient connectivity to PCs. Additionally, the HMI with Keypad functionality allows customers to change function codes and modify the display layout.

“Fuji Electric continues to develop products that solve specific problems for our customers, and provide them with a reliable solution that’s going to get the job done for many years to come,” added Schrader. “The FRENIC-



Ace is a great addition to our existing product lineup, with the features and benefits that OEMs need.”

For more information:

Fuji Electric Corp. of America
Phone: (732) 201-3842
www.americas.fujielectric.com

Encoder Products

OFFERS MODEL 30MT ENCODER

Encoder Products Company (EPC) has introduced the all new Model 30MT, a low-profile 30mm diameter magnetic encoder module. By means of advanced sensing and signal processing technology, the Model 30MT provides accurate incremental feedback, even in harsh operating conditions. With its threaded housing, the Model 30MT is simple to install. See the unboxing video for an overview.

Designed for tough industrial environments, the Model 30MT offers sealing up to IP69K and is virtually impervious to dust, dirt and moisture. The Model 30MT features a chemically inert high-temperature nylon composite housing and non-contact magnetic sensing. The encoder is capable of operating in temperatures from -40° C to 120° C and features a threaded housing for easy installation. With a generous sensor-to-magnet air gap of 0.022", the Model 30MT holds ratings of 100g at 11ms for shock and 20g at 10 to 3,000 Hz for vibration.

Even with its tough housing, the Model 30MT features advance signal processing circuitry which allows for a wide sensor-to-magnet air gap while still providing excellent waveform symmetry and repeatability, delivering signal accuracy exceeding that of many magnetic encoders.

The Model 30MT is a versatile, cost-effective solution for non-contact, end-of-shaft rotary feedback in commercial, industrial and non-industrial applications. Some examples are: servo or stepper motor control; mobile equipment speed and steering sensing; timber processing machinery; studio and stage equipment; solar panel positioning; vending machines; rotary valve positioning; punch presses; and robotics.

For more information:

Encoder Products Company
Phone: (800) 366-5412
www.encoder.com



Martin

Quality PT Products
In Stock When & Where
You Need Them



Martin products are stocked
in more than 30 North
American branches
and MTO's ship same
day or next day from
a location near you.



Free PT Maintenance &
Troubleshooting Guide
Scan or visit
<http://bit.ly/2aQL322>
to download!

www.martinsprocket.com
817-258-3000

Moticont

ADDS TWO LINEAR MOTORS TO SDLM SERIES

Moticont has added two linear motors to its SDLM series of high speed direct drive linear motors which are also known as electric cylinders. These direct drive linear motors feature resolutions of 5 μm (0.000197 in.) and 1.25 μm (0.000049 in.) The integral, linear optical quadrature encoder directly connects to the shaft for the greatest possible accuracy.

Each motor features a continuous force rating of 20.1 oz. (5.82 N) and a peak force of 66.3 oz (18.4 N). This motor is designed with a larger air gap of 0.059 in (1.5 mm). The larger airgap allows the motor to be used for vibration, noise cancellation, photonics, gimbals, antenna positioning, medical devices, semiconductor handling, SMT machines, assembly, wafer handling, optical focusing, dynamic vibration absorption, scanners and laser beam steering and filtering where excessive side play or tilt is required.

The non-commutating SDLM-025-095-01-05 (5 μm resolution) and the SDLM-025-095-01-01 (1.25 μm resolution) Direct Drive Linear Motors have quiet long life plain linear bearings, a non-rotating shaft, pre-drilled and tapped mounting holes, and threaded (internal) ends of the shaft for easy integration into new and existing applications. These low cost direct drive motors are coupled directly to the load



providing high acceleration and speed with zero cogging and no backlash as with other drive systems such as ball screws, gear, and rack and pinion drives.

The SDLM-025-095-01-05 and SDLM-025-095-01-01 Direct Drive Linear Actuators are also available as a complete plug-and-play linear motion system with a matching motion controller.

For more information:

Moticont
Phone: (888) 785-1804
www.moticont.com

Zero-Max

ETP-EXPAND IMPROVES PUMP DRIVE CONNECTION

Connecting a rotating piston lobe to a hollow shaft has been improved using the ETP-Expand, a patented bushing device that is fast and easy to install and adjust. The ETP-Expand was developed to simplify exchanging seals in pumps when fluid viscosity is changed. This is often required in pharmaceutical, chemical, food and beverage processing systems with the seal change needing to be done quickly and easily.

ETP-Expand is a device that con-

nnects to a hollow shaft, locking the impeller/lobe wheel of the pump motor into position using just one actuation screw. Considerable space-savings are gained by mounting within the hollow pump shaft.

No Axial Movement When Tightened

The ETP-Expand is a patented precision bushing designed just for pump applications. Its unique design configuration accurately expands OD of the

ETP Expand when a single actuation screw is tightened. Since the expansion is caused by self-contained hydraulic pressure, the resulting force is perfectly even along all surfaces. Most important, the bushing aligns precisely without axial movement as it is tightened. The positioning is very accurate and takes just seconds.

Another key feature is its robust and precise design allowing it to be actuated thousands of times with repeatable accuracy and without any axial movement. An Allen wrench is all that is required to mount and lock it into position. ETP-Expand has sealed, clean lines that resist debris collection and cleans easily without any special maintenance. These features increase the efficiency of the pump system for a lower total operating cost.

For more information:

Zero-Max
Phone: (800) 533-1731
www.zero-max.com



SG Transmission

DESIGNS CURVED PERMANENT MAGNET BRAKE

SG Transmission has designed a curved permanent magnet brake to be used in specialist medical equipment. The customized brake has been designed to control the height of a vertical and extendable pole, which moves linearly in oncology treatment machines.

The dual curve surface brake increases the working face of the brake to match that of the curvature of the pole, this ensures maximum contact and therefore a higher holding force.

Paul Short, technical manager at SG Transmission said: "As this brake is used in an operating theatre to control a system suspended above the patient, it is very important to the customer that the brake is fail-safe. In the event of a power failure, the suspended weight of the mechanism must not fall freely. The challenge was to maximize the working pole area within a specific envelope size to suit the customer's needs. We delivered this unique concept to the customer in just 15 days."

This bespoke, curved brake is suited to applications in the medical, military and robotics industries, due to its precision, increased holding force and fail-safe qualities.

For more information:

SG Transmission
Phone: +44 (0) 1388 770 360
www.sgtransmission.com

Iwis Drive Systems

INTRODUCES MAINTENANCE-FREE
STAINLESS STEEL CHAINS

Iwis Drive Systems introduces b.dry maintenance-free stainless-steel chains. The corrosion-free chains run completely dry, are extremely wear-resistant and withstand high dynamic loads. They are also maintenance-free and do not need any form of lubrication. These characteristics make them predestined for use in aggressive environments, for applications in which water or steam are applied or where strict cleaning regulations apply, such as the food and pharmaceuticals industries, in cleanrooms and in painting lines.

The new b.dry precision chains are suitable wherever relubrication is undesirable or not possible. They are hy-

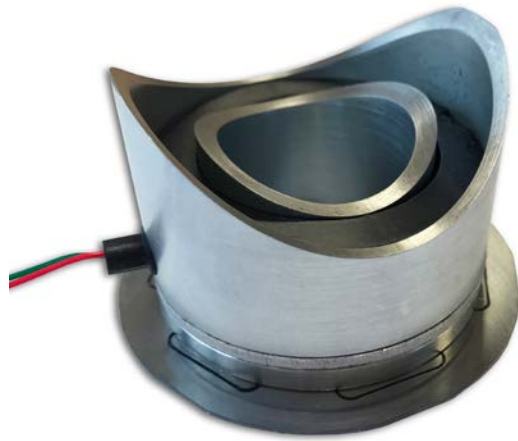

The Power of One²

Your Objective:

One face in perfect alignment with another. *For infinity.*

No problems. No distress. No delays.

That's the same objective you have for choosing your gear producer. Circle Gear's objective is to engage with every customer's objectives.

- ▶ One to 1000 gears
- ▶ Customer designed or reverse engineered
- ▶ Gearbox repair, rebuild or redesign
- ▶ OEM or end-users
- ▶ ISO 9001:2015 Certified

1501 S. 55th Court, Cicero, IL 60804
(800) 637-9335
(708) 652-1000 / Fax: (708) 652-1100
sales@circlegear.com
www.circlegear.com



Spiral and Straight Bevel Gears (*Cut, Ground or Lapped*) • Spur Gears • Helical Gears • Long Shafts • Herringbone Gears • Involute and Straight Sided Splines • Internal Gears • Worm and Worm Gears • Racks • Sprockets • ISO Certified



Partnering with QualityReducer to provide
Gearbox repair, rebuilding and reverse-engineering.

gienic and run completely dry. Thanks to the high-performance plastic friction bearings in their links, they need no lubrication of any kind, which also eliminates the need for relubrication. Made from a high-performance polymer, the sleeves are heavy-duty, low-friction and FDA-compliant. Contact with foodstuffs or hygiene products is safe. The stainless-steel bushes are thin-walled, seamless and ball-drifted. The CF base chain is made from austenitic stainless steel, making it highly resistant to aggressive media. The wear life of the b.dry chains is significantly long. They can be used in a temperature range from -100 to +200°C. They are also available as roller chains with attachments or extended pins. Custom-developed chains and ANSI chains are also available on request.

For more information:

Iwis Drive System, LLC
 Phone: (317) 821-3539
www.iwisusa.com



Rexnord

LAUNCHES SMART SPHERICAL ROLLER BEARINGS

Designed as an off-the-shelf solution for quick turnaround needs, Rexnord recently launched its new Industrial Internet of Things (IIoT) Smart PT Select Mounted Spherical Roller Bearings offering. These bearings are ideal for conveyor and fan and blower applications in the aggregate, air & fluid handling, cement, and material and package handling industries. A suite of digital technology is built into and around this bearing offering to make customers' jobs easier. Features include:

Product specific QR code — each bearing tag features a laser-etched QR code that enables the user to quickly access product specific information such as how to videos and instruction manuals from their mobile device.

Dedicated mobile app — Rexnord has updated their no-cost Bearing Mobile Pro app to include the capability to scan the product specific QR code found on each bearing.

Proven quality — every bearing is tested before it ships, including custom, state-of-the-art testing for quality and reliability, spin testing under load, and backed by the standard Rexnord one-year warranty.

Off-the-shelf solutions for quick turnaround — designed using the latest techniques, combined with decades of application knowledge, and provides durability and value for a wide range of in-stock configurations for fast turnarounds.

Engineered bearing seals for increased product life — standard triple lip and clearance seal provide maximum ingress protection against contaminants; clearance seal reduces operating temperatures at higher speeds; and features nitrile material with protective metal shield.

For more information:

Rexnord Corporation
 Phone: (414) 643-3000
www.rexnord.com/PTSelect



GEAREXPO
2017
THE DRIVE TECHNOLOGY SHOW



WHAT DRIVES YOU

Gear Expo drives innovation. It's where power transmission and drive technology experts come to discover advancements in the gear industry. In addition, our education courses will keep you up to date on how to avoid gear and bearing failures, gearbox maintenance and lubrication.

Drive home with new insights and technology for your business.

FOR MORE INFORMATION, VISIT
www.gearexpo.com/pte

NETWORKING, ON-SITE DEMONSTRATIONS, AND TOP-NOTCH EDUCATION

JOIN THOUSANDS of design, manufacturing and application engineering professionals as well as gear buyers and manufacturers to network and build relationships that drive profits for your company.

EXPLORE A SOLD-OUT EXHIBIT HALL filled with the latest equipment and machines to make your operations more efficient and your systems made to the highest quality. See them in action firsthand.

GET NEW IDEAS during education sessions led by industry experts who provide relevant and timely solutions to the challenges you and your team face every day.

October 24–26, 2017

Columbus, OH
Greater Columbus Convention Center

Why Direct Drive?

Brian Zlotorzyski, Product Specialist, ETEL Motors

Direct drive technology has been around for over 40 years. Despite this, there still is a lack of understanding by many machine builders. Even those who are familiar with it, may not have a desire to adopt the technology, considering it as too high-end when compared to, for example, a gearbox drive solution which has been “good enough” for many years. But in the same way smart phones and the Internet have evolved from a luxury to a necessity, despite lower-end technology still existing (*there ARE those who still buy flip phones, as well as still about*

two million people who use dial-up), eventually the benefits of a more advanced technology becomes too difficult to ignore.

In today’s highly competitive world, the better someone understands the advantages and benefits of direct drive technology, then the more they will have an advantage in machine building, giving them an edge over their competition.

To understand these benefits, we start with the basic concept of direct drive whereby the force of a motor is directly applied to a mechanism without any intermediate drive train such

as a gearbox or toothed belt etc. The core working principles of direct drive motor technology is in essence based on the right hand rule of electromagnetism, whereby a current moving through a wound coil creates a magnetic field (Figure 1). Changing the direction of current changes polarity and changing the amount of current changes the magnetic force. Put a highly conductive material within the coil, such as iron, and the magnetic force is increased exponentially (Figure 2).

The last factor is to have some magnetic material for this field with which to interact. In this case, it is a row of permanent magnets. Depending on the coils location relative to the magnet, the current can be adjusted in terms of its strength and polarity, creating a push/pull force on the magnets. The resulting force is capable of moving an object without making physical contact. This force generates a linear motion when using a flatbed track of magnets and a rotary motion when using a curled-up ring of magnets (Figure 3). The applications may be different but the technology is exactly the same.

It was mentioned before that to get the desired motion, the coils (each called a pole) need to change their polarity and strength relative to the magnets to maximize the force delivered. The standard nowadays is for there to be three different coil behaviors, called phases, acting upon the magnets at the same time (Figure 4). For this reason, the type of motors using this method are called 3-phase synchronous motors. All that a motor has as an input when it comes to performance are three wires for current and, for this reason, motors do not have any compatibility issues with different controllers.

Once the working principal is understood, it is easier to see the benefits of this technology. One of the advantages is the large force density it brings. With the motor having only two parts - the magnets and coils, they are incredibly

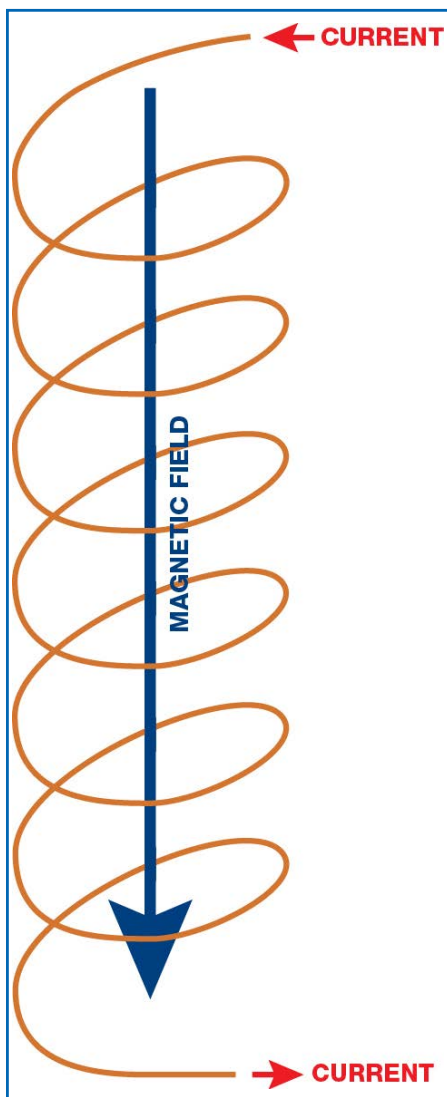

Figure 1 Ironless motors have a weaker force.

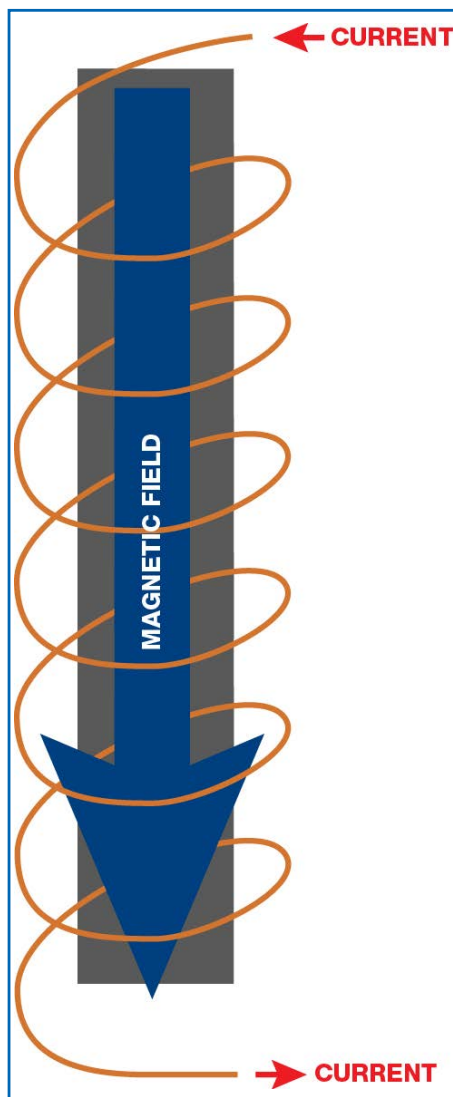

Figure 2 Iron is used to vastly increase the force.

compact for the power they deliver. The small moving carriage of a linear motor and the large hollow shaft of a torque motor allow the payload to be mounted directly to the motor, ensuring making the most of the space within the machine. This also delivers a high mechanical stiffness and allows for a greater dynamic range of motion since the forces are not being transferred through multiple parts, which also eliminates backlash and inertia mismatch.

This result is a force transmission method that can perform over a wide range of force and speed without having to make mechanical adjustments, and whose performance and precision is only limited by the feedback device to which it is attached. With these types of benefits, one may wonder why it is not more widely adopted. The reason mostly revolves around upfront price and complexity of integration. Because of cost of material, mostly the permanent magnets, there is a hesitation towards making the investment to switch over.

Along with that, when someone is already familiar with a gearbox or ball screw solution, its familiarity can be comforting. Dealing with those two factors at the beginning can look very intimidating but what needs to be understood is that a lot of the value from direct drive comes from its long term use. If a machine maker is able to make the most of its performance, they are able to greatly increase the throughput of the machine and not have the cycle interrupted with a machine down due to maintenance and part failures. When properly integrated, the user has a motor that could be operating 10 years down the line and will perform just as well as one that is newly installed.

Every year, more machine makers are seeing the benefits of direct drive but to get the most out of them, it is important to understand their limitations as well. The concept of the force transmission being coupled directly to the payload is similar to the concept of semi-closed loop when it comes to encoders. The idea being that the less “degrees of separation” between the part, the greater will be the overall

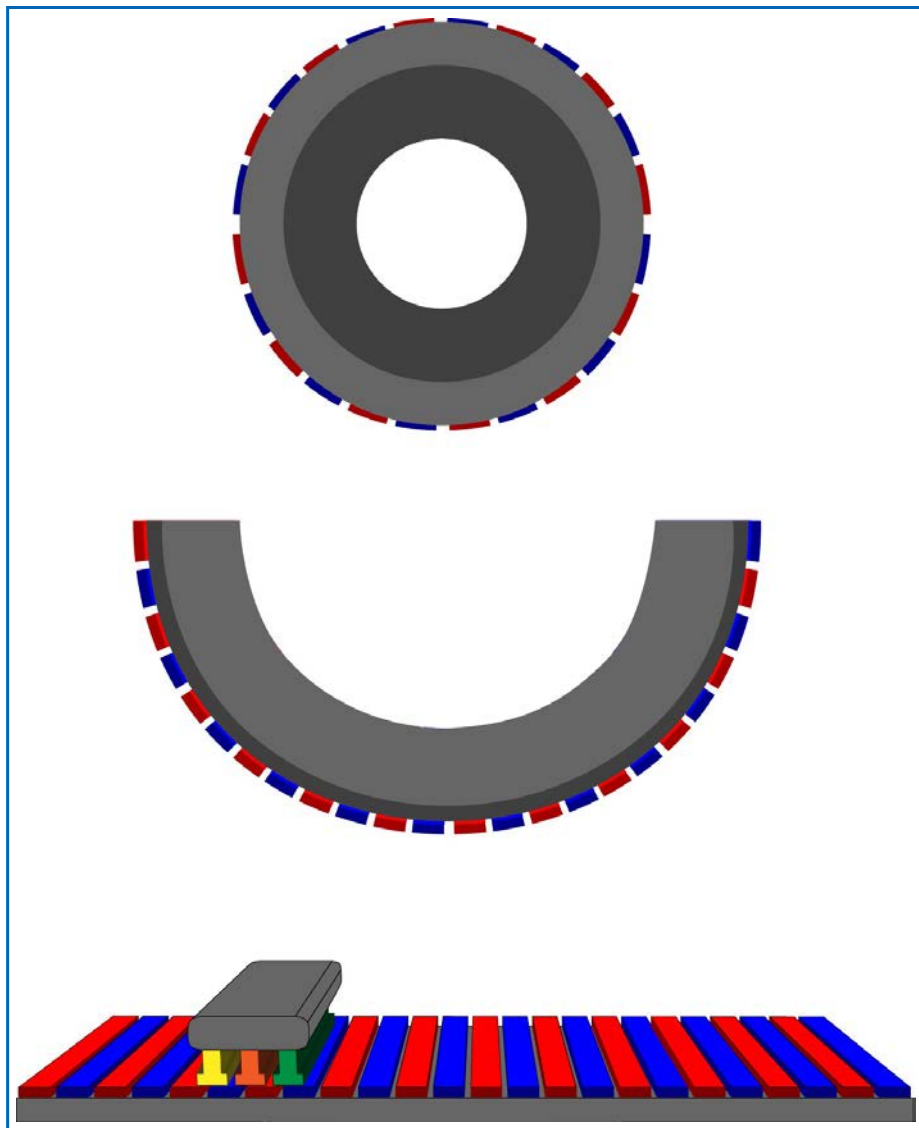

Figure 3 Torque and Linear motors operate on the same principles.

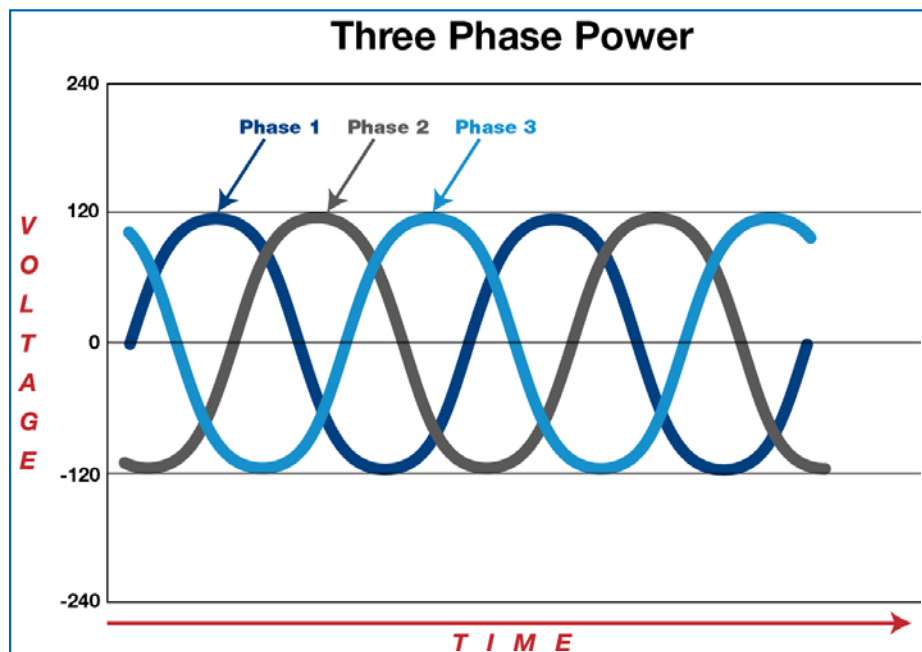

Figure 4 It's ideal to have current the strongest when a coil is between the magnets.

performance. If the reader imagines the different components as parts of the human body: the controller as the brain, encoders as the nervous system and the motor as the muscle. You can have one of the strongest muscles out there but if the signal to it is muddled or cut off, then you are not going to get the proper movements. Like the human body, if you are not careful, the user can run the risk of overexerting and damaging a motor.

Most of the time, a motor's performance is limited by how much force/torque a motor can output without overheating. The better this is controlled, the more performance is available from a particular model.

Take a look at the continuous value of the motor (Continuous Force with linear and Torque with rotary); this is an average value a motor can run at 24/7. This value is the most malleable since it is very dependent of how the motor is able to dissipate heat. If the motor has some type of heat sink or is liquid cooled, there is a noticeable increase in performance, sometimes even doubled with liquid cooling due to how much heat is dissipated. Getting the exact values are realistically a matter of trial and error but pay attention to any guidelines given on a datasheet for what is being taken into account.

A motor is able to perform well above the continuous value up until the peak value. The motor is physically unable to go higher than this value typically because it is the point where so much current is added to the coils, the user runs the risk of demagnetizing the magnets. Although not as flexible as the continuous value, the time a motor can reach the peak varies from as long as two seconds to tens of milliseconds so be sure to get an idea of the length of time if it is a point hoped to reach. If heat generation is thought of as the integral of the force value, this should give you an idea of how it all comes together.

Speed is one more value that can vary the performance. Going back to the basic concept of magnets and coils, when the magnets move past the copper coils, a current is created within the copper and creates a Back-

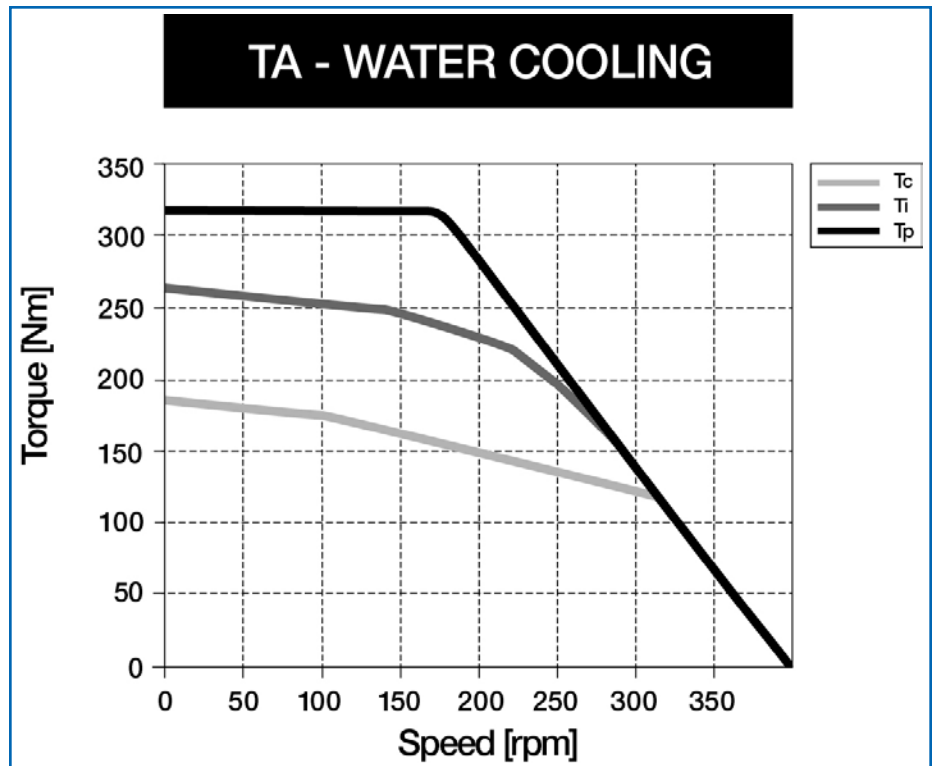

Figure 5 The diagonal slope is where Back-EMF is too much to counter.

Electromotive force (or back-EMF) Voltage. To compensate, the controller has to input more current to counteract this current normally used to give the motor its power. The result is that the greater the speed at which the motor operates, the more difficulty it will have reaching similar force values than if it were operating at lower speeds. The greater the surface area between the magnets and coils, the greater the Back-EMF which is why a motor has lower speed capabilities as it gets larger or has more poles. Although this is not the only property that affects this (Eddie currents can occur and heat up parts of the motor), it is what affects it the most (Figure 5 shows how all these factors affect speed in a TMB+ torque motor (0210-07-TA2SP)).

Direct drive is a very advanced technology, to the point where each concept mentioned previously can be developed into its own article. The point here is to understand what this technology is, what the benefits are that machine makers can take advantage of and the meaning behind the most important parameters.

From there one can expand their knowledge of key direct drive principles to be as efficient as possible but, at the very least, one could start with a framework to develop an understanding. From there, it is a matter of deciding the value of investment that direct drive can offer for a new machine design. Different companies have different levels of investment into direct drive technology and, in the case of ETEL, it has been the focus since the inception. From machine tool, to aerospace to semiconductor manufacturing, direct drive has increased the quality of manufactured products in many industries. As the standard of quality increases, the machines will need to adapt to the newest and best technology and direct drive is a prime example of how this can be achieved with a method that promises to be here for years to come. **PTE**

Brian Zlotorzycki is Heidenhain's Product Specialist for ETEL Motors. As a leading international supplier of direct drive and motion control components and integrated systems, ETEL supports high tech industry with linear motors, torque motors, positioning stages, and motion controllers/systems. ETEL S.A. is based in Switzerland with exclusive North American distribution through Heidenhain Corporation in Schaumburg, IL.



APRIL 3-6, 2017 | MCCORMICK PLACE | CHICAGO, ILLINOIS

North America's Broadest Automation Solutions Show

AUTOMATE • 2017



Connect.
Discover.
Grow.



HERE'S
WHY YOU
SHOULD
ATTEND

Connect with top suppliers and industry experts

Discover new technologies, and learn how automation can benefit your company

Grow your business using knowledge gained on the show floor, at Expert Huddles, and in the conference sessions

REGISTER TODAY!

Free registration available at:
AutomateShow.com/PTEngineering

Brought to you by



Collocated with  PROMAT 2017

Saving Time with Auto-Tuning Drives

Auto-tuning drive software is becoming more sophisticated than ever, making it easier than ever to save time in the face of talent shortages.

Alex Cannella, News Editor

If there are two things that are in tight supply in the industry, it's time and talent. Manufacturers are always pressured to do more faster, and the industry is producing fewer experts to help them do it, so the industry's had to get crafty and find what time-cutting procedures they can.

In such an environment, an auto-tuning drive's appeal is self-evident: instead of tinkering around with a drive for a few days to get it whipped into shape, just let the drive do it itself in a matter of hours. It not only takes less time, but also requires significantly less expertise than tuning a motor manually does. No muss, no fuss; just hit a button and the drive will take care of it for you. It's a straightforward and sensible pitch for manufacturers strapped for time and/or expertise.

"You don't need to be a seasoned motion control engineer that has been dealing with these things for 10 or 15 years," Scott Carlberg, Yaskawa's product marketing manager, said. "It's very simple to apply."

Auto-tuning drives themselves are nothing new. According to Joaquin Ocampo, Bosch Rexroth's product manager for electric drives and controls, the company's been utilizing them since before he started working at the company 17 years ago.

"This is something I really take for granted..." Ocampo said. "I just hit the enter button and everything's good to go."

But depending on how precise you need your drive to be, auto-tuning drives may not have historically been sophisticated enough to follow through on their promise. According to some, such as B&R Industrial Automation's Solutions Engineer, Derrick Stacey, they still aren't enough for high-end applications that require extreme precision. He sees auto-tuning's benefits differently, as a quality assurance tool that pays dividends down the road.

"It only knows what you tell it at the start," Stacey said. "You have to give it the best possible start position, and then as it sees how it's operating and changes in operation, it can make intelligent decisions to adapt its tuning loops

Many of Yaskawa's products, such as the Sigma-7 servomotors (pictured here), come with 24-bit encoders, which are pushing the boundaries of what Yaskawa can do in the realm of auto-tuning.



and increase or decrease the forward parameters."

If it isn't apparent yet, the auto-tuning drive's place in the industry is something everyone has a different opinion on. While they may be a regular presence in the industry that some use without giving much thought, everyone seems to disagree on their exact function, and so that begs the question: when will you benefit from using an auto-tuning drive?

According to Ocampo, auto-tuning drives can save you an hour of labor here or there during setup, but they're sometimes not even necessary. While third-party motors can still necessitate some setup, Ocampo noted that many of Bosch Rexroth's systems already work together well enough that auto-tuning often isn't required.

"With [Bosch Rexroth's] systems, auto-tuning is not necessary," Ocampo said. "Hard to believe in some cases, but I would say, if you want a number, like 99 percent of all the applications work straight out of the box when you put the motor and the drive together as long as it's sized correctly."

Carlberg, on the other hand, has seen Yaskawa's auto-tuning algorithms pay out great dividends in saved time with some of the company's customers.

"We get customers giving us feedback that 'hey, you know, we did everything that used to take us two weeks, we're doing it now in two days,'" Carlberg said.

Auto-tuning's effectiveness largely comes down to how

precise your application requires your drive to be. Auto-tuning drives are by no means infallible, and the more precision you require, the less benefit you're going to see from them. The highest end applications can still benefit from auto-tuning drives to get in the ballpark of where they need to be, but an expert is still going to have to go in and fine tune the drive further.

"In most applications, that level of tuning is not the most you can get out of these servo systems," Carlberg said. "But in the majority of applications, it's good enough. It's so easy to just leave it in that adaptive mode. A lot of our customers are really leveraging that and using it as a selling factor."

"With the use of three or four different auto-tune methods, you can get yourself in a pretty good spot," Stacey said. "And then only sort of really rigorous requirements would require you to do a lot of hands on work...You have to define where you are...Do you need sub-micron position accuracy? Are we talking sub-millimeter? Are we talking within a few millimeters?"

But like everything else automation-related in the industry, auto-tuning drives are getting more sophisticated by the year, and they've come far enough along that it may be worth taking a second look. According to Carlberg, advances in processing speed have opened up new avenues for Yaskawa to develop more and increasingly complex auto-tuning software that is not only more accurate than past iterations, but can also maintain and preemptively adjust a

drive's performance as it works.

"The main thing that's allowing us to create some of this new technology is processing speed," Carlberg said. "As all the servo companies are developing new products, the microchips get faster and faster, the processors get faster and faster and smaller. So really, the motion control industry's kind of been able to leverage that additional power and throughput to create some really cool stuff."

Amongst that "cool stuff" are several motion control algorithms that come standard on Yaskawa's amplifiers. Some of their algorithms, such as their Tuning-less Mode, fill fairly standard auto-tuning roles. When a drive is connected with Tuning-less Mode activated, it is constantly communicating with one of Yaskawa's 24-bit encoders to detect the drive's load inertia, then automatically adjusts the drive's tuning gains to optimize it for that level of inertia.

"A lot of our customers are leaning towards that instead of going in and kind of fine-tuning the system," Carlberg said. "It makes it so much easier for a machine builder because every machine that a machine builder makes, they're going to have variances in the mechanics. This essentially just kind of takes care of that. You don't have to spend a week commissioning the whole machine before you ship it out. You just set this up in the Tuning-less Mode, and then it kind of just works. You don't have to spend a bunch of time with it."

Tuning-less Mode also accounts for the inevitable wear and tear of a machine's continued use, adjusting drives over time to allow them to continue operating as well as they did when they were first installed, and can track sudden changes in load. If, for example, a robotics arm in a production line were to pick something up, Tuning-less Mode can notice the change in the load and automatically compensate.

Stacey has noticed similar offerings to Yaskawa's Tuning-less Mode appearing on the market in recent years, and pointed it out as one of the primary and most noticeable ways auto-tuning drives have advanced in recent years.

"The drives are smart enough to adjust their filters," Stacey said.



Many of Yaskawa's motion control algorithms are available across most of their products.

For Related Articles Search

motor controls

at www.powertransmission.com

“So as systems wear, or the system response changes, you can actually adjust where a filter would exist...Something like that was nonexistent five years ago.”

Some of Yaskawa’s other algorithms fill more niche roles. The vibration suppression algorithm, for example, hammers out a machine’s resonance points in real time. When working manually, engineers need to test and plot out where a drive’s resonance points are, then apply a number of filters in the software to try and diminish them as much as possible. Yaskawa’s vibration suppression system takes the entire process and automates it, gathering the data and setting filters as it locates vibrations without ever having to even turn the drive off.

“As your machine’s moving, it detects exactly where these disturbances are, and it’s setting notch filters, anti-resonance filters, anti-vibration filters at different frequencies,” Carlberg said. “It’s setting these filters up automatically to do all that for you. What traditionally could take a few days in the past, it’s doing all that automatically.”

Yaskawa has also developed an algorithm for recording errors. When all else fails and an error occurs in a drive, Yaskawa has an algorithm that records what state the drive was both prior to and immediately after the error occurred. This prevents technicians from having to replicate an error to see what caused it, saving both time and sanity when trying to pin down the source of the error.

“We’re constantly recording the state the product’s in for a certain amount of time that’s user definable...” Carlberg said. “Whenever an alarm occurs, the amplifier has a snapshot of some amount of time previous to the alarm and just after the alarm occurred, and you can pull that up after the fact.”

B&R has developed their auto-tuning software in other directions. One primary difference between them and other companies is that they’ve put the tuning information in the PLC instead of the drive itself. That way, if a drive is replaced for whatever reason, a new drive can take its place, upload the old drive’s tuning information from the PLC, then pick up exactly where its predecessor left off.

“Some other manufacturers may require you to plug into your ethernet port or serial port directly on the drive and then set up each individual drive,” Stacey said. “We wanted that to be a thing of the past, and we actually focus on everything being managed by the main controller.”

One other additional benefit Stacey has seen recently has been developed thanks to the increasingly prevalent technologies that fall under the Industrial Internet’s umbrella. In particular, strides forward in machine self-analysis that are a major facet of the Industrial Internet go hand

in hand with the concept of auto-tuning drives. As drives continue to become more self-analytical, one natural route of development is preemptive maintenance. With increasing amounts of data being studied more frequently by the drive, potentially fatal breakdowns or errors can be caught more easily.

“You’re really spending money when you don’t have to just to ensure that you never have unplanned downtime, and as systems can be made smarter, you can actually predict when downtime will occur and shift when it will occur by allowing a PC or PLC to learn about how it’s working. So I think that will be the future step: giving drives the ability to adapt themselves to get the most out of the mechanical components they’re plugged into.”

According to Stacey, the future of auto-tuning drives largely rests with the Industrial Internet. It’s a theory that makes sense, as automation, the auto-tuning drive’s *raison d’être*, is one of the major cornerstones of the Industrial Internet, and will doubtless see many advances in the foreseeable future.

“As our PLCs get smarter and smarter, I have a feeling things are going to really take off as far as more advanced auto-tuning,” Stacey said.

However, Stacey also believes that there will always be a place for the motion control technician. No matter how smart a drive might become, there will always be high-end applications that will require that human touch to calibrate just right.

“I don’t think [an auto-tuning drive] will ever replace a knowledgeable motion control expert,” Stacey said. “But what it will be able to do is after that expert gets their hands on a system and starts it up and gets it running as expected, then over time, it will be able to make intelligent adjustments from what that expert did.”

For more information

B&R Industrial Automation Corp.
(770) 772-0400
www.br-automation.com

Bosch Rexroth
(800) 739-7684
www.boschrexroth.com

Yaskawa America Inc.
(847) 887-7457
www.yaskawa.com

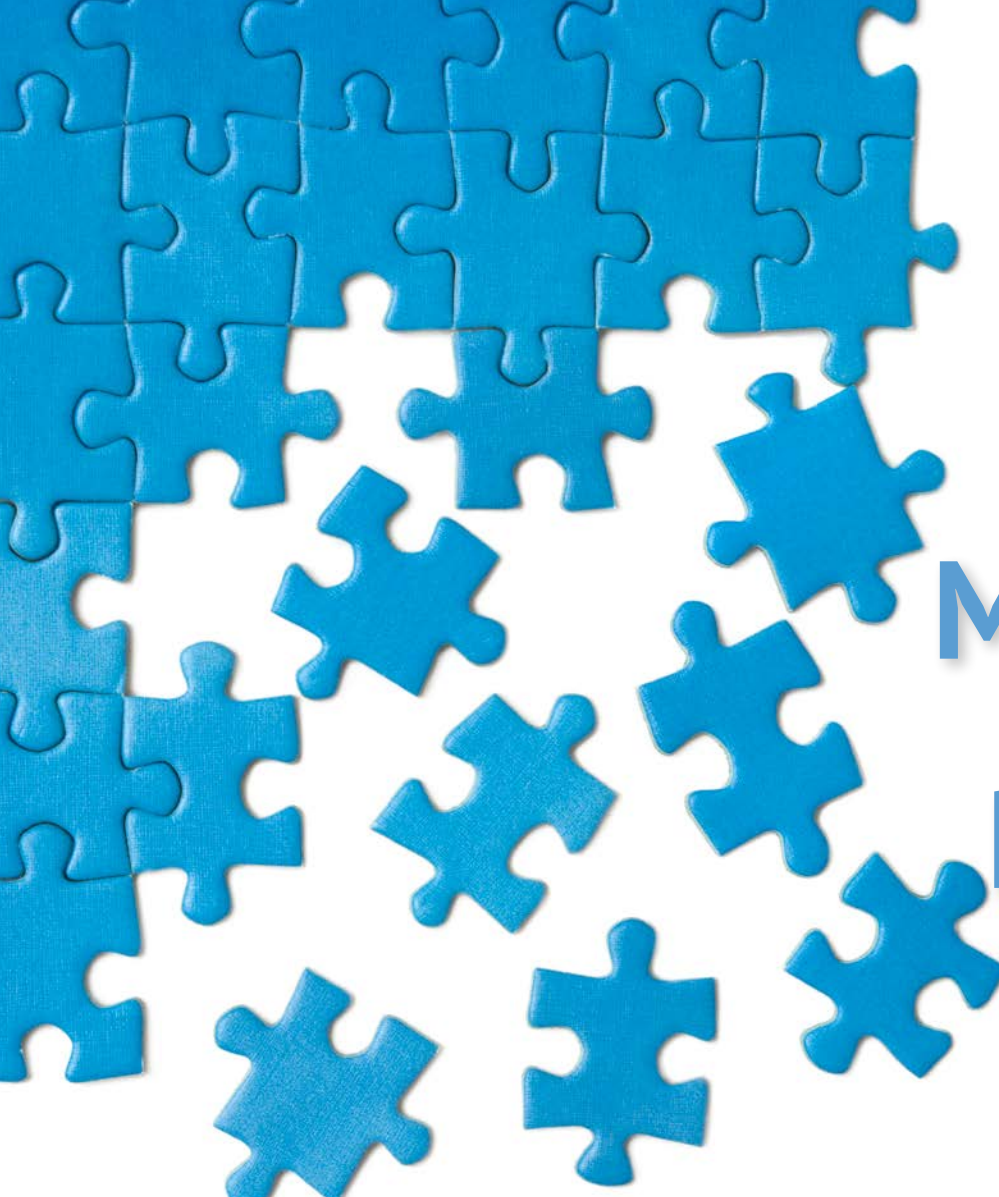

MISSING A PIECE?

We've got you covered! Go to powertransmission.com to see what you missed in last month's issue, plus another eight years of back issues, industry and product news, and more!

In last month's issue:

- Our annual Buyers Guide
- Choosing chain or belt drives
- The industrial Internet is changing everything
- Preventing Roller Bearing Failure

... and more!

Power Transmission Engineering

Devising New Devices

Medical Device Industry Continues to Grow and Innovate

Jack McGuinn, Senior Editor

Trying to get one's mind around the staggering dollar figures generated by the U.S. medical device industry is a daunting task. And unlike the countless 24/7 television ads from Big Pharma promoting, for example, the latest blood thinner medication or antidepressant or pain reliever, we rarely see widespread advertising for medical devices. Perhaps it is because, unlike many medications, using any of these devices is typically not a matter of choice. Rather, it is very often a matter of life or death — as with pacemakers, defibrillators, surgical robots, etc. And these devices are used *everywhere* — from the biggest metropolitan hospital centers to the smallest private practitioners.

So it is little wonder that, according to Government reports, “The United States remains the largest medical device market in the world, with a market size of around \$148 billion, and it is expected to reach \$155 billion by 2017.”

Other key numbers, according to the report (www.selectusa.gov/medical-technology-industry-united-states) — “The U.S. market value represented about 43 percent of the global medical device market in 2015. U.S. exports of medical devices in key product categories identified by the Department of Commerce (DOC) exceeded \$44 billion in 2015. There are more than 6,500 medical device companies in the United States, mostly small and medium-sized enterprises (SMEs). More than 80 percent of medical device companies have fewer than 50 employees, and many (notably innovative start-up companies) have little or no sales revenue. Medical device companies are located throughout the country, but are mainly concentrated in regions known for other high-technology industries, such as microelectronics and biotechnology. The states with the highest number of medical device companies include California, Florida, New York, Pennsylvania, Michigan, Massachusetts, Illinois, Minnesota and Georgia.”

The medical device universe, by application:

- **Electro-medical equipment.** Includes a variety of powered devices, such as pacemakers, patient-monitoring systems, MRI machines, diagnostic imaging equipment (including informatics equipment) and ultrasonic scanning devices.
- **Irradiation apparatuses.** Includes X-ray devices and other diagnostic imaging, as well as computed tomography equipment.
- **Surgical and medical instruments.** Includes anesthesia apparatuses, orthopedic instruments, optical diagnostic apparatuses, blood transfusion devices, syringes, hypodermic needles and catheters.



- **Surgical appliances and supplies.** Includes artificial joints and limbs, stents, orthopedic appliances, surgical dressings, disposable surgical drapes, hydrotherapy appliances, surgical kits, rubber medical and surgical gloves and wheelchairs.
- **Dental equipment and supplies:** Includes equipment, instruments, and supplies used by dentists, dental hygienists, and laboratories. Specific products include dental hand instruments, plaster, drills, amalgams, cements, sterilizers and dental chairs.

And don't forget the design-specific software that helps make all of the above possible. But that's another story for another day/issue.

Advocating and facilitating all of this activity is the Medical Device Manufacturing Association (MDMA). Formed in 1992, the MDMA's primary mission seems to be lobbying in D.C. for the industry's best interests. On its website (medicaldevices.org) we learn, “The medical device industry has seen significant regulatory changes in recent years, affecting legal and administrative issues, relationships with providers and more. Members benefit from MDMA's expertise on compliance issues through interacting with key government enforcement officials, legal experts and other member companies to discuss best practices.”

Unlike say, the American Gear Manufacturers Association (AGMA), the MDMA is not a font of knowledge regarding engineering and manufacturing processes. But they will soon have available a “compliance toolkit” for members that includes “sample governance documents, training documents and auditing documents.” Relatedly, MDMA's Compliance Working Group typically meets on the last Tuesday of each month (2:00 p.m. ET via teleconference).

The MDMA also informs: There are “numerous provisions of the Affordable Care Act (ACA) that continue to be implemented, impacting med tech innovators and all stakeholders in the health care delivery system.” Also on the group's target

list: lead the effort to repeal the medical device tax; ensure that the regulatory environment is more predictable and reasonable; and that there is a fair and adequate reimbursement system in place for medical technology.

You may think the manufacture of these devices requires exceptional skill and attention to detail, and you'd be correct. That extra attention helps in making, for example, extremely precise FDA-certified injection-molded plastic parts and gears, or absurdly toleranced CNC-machined metal gears, as well as components like slewing drive controls with required zero backlash and many other parts.

(Before going further, it should be noted that the 3-D printing of gears and other medical device components is definitely a technology with momentum. And while the insanely fast, 3-D printing of pricey prototype parts is a huge benefit for product designers and production managers, other 3-D-print-generated wonders await. Or have already arrived; folks—we're talking *body parts*. Look to future issues for more 3-D-related content regarding 3-D technology's role in power transmission or medical device updates.)

We talked to two companies—one making metal gears for the medical machine/device industry, the other a supplier of plastic gearing—in order to get a better understanding of how this extremely complex, extremely niche industry works. Contributing are George Diaz, general manager, The Gleason Works-Gleason Plastic Gears; Brian Springer, Gleason senior plastic gear engineer; and Brian Dengel, general manager, KHK-USA.

PTE. Which plastics are typically being converted for medical device components?

Brian Springer: Gleason Plastic Gears has developed strategic relationships with all the resin suppliers in the world! Material (plastic resin) selection is highly dependent on the specific application(s). For gearboxes, the operating temperature and gear loadings (torque, speed and operational mode) will drive material selection. If the application involves human contact, plastic resin must be

cleared for use per ISO 10993 and United States Pharmacopeia (USP) guidelines. It is important to note that material selection may also be impacted by the medical device's sterilization requirements.

Brian Dengel: We recommend food grade (FDA) nylon as it is suitable for washdown environments.

Which metals (titanium for example) are best-suited for metal medical device components?

Springer: Stainless steel has been the most commonly used metal in medical devices for quite some time due to low cost.

Dengel: We recommend 303 stainless steel for these applications.

Is strength the greatest attribute for metal gears in medical devices?

Springer: This is also highly dependent on the application, but I would say yes. Typically metal gears would only be used in medical applications if a plastic gear is not strong enough, or will not last long enough. Metal gears are typically a bit more expensive, heavier, and noisier. Plastic gears provide significant advantages in cost, weight and noise.

Dengel: Strength is the primary advantage. Nylon gears can be used but need to be sized accordingly. If the package size is the controlling variable, then metal gears are preferred. If size is not the controlling variable, then use of a nylon gear will eliminate the need for lubrication, will allow for quieter operation and will absorb some vibration in the system.

Please explain what a manufacturer must do to gain certification for the manufacture of medical components. Are both the ISO and the FDA involved in certification?

George Diaz: In order to manufacture and ship finished goods (medical devices), the FDA requires that the site be



photos courtesy KHK-USA.

a FDA registered facility that complies with ISO 13485. Gleason Plastic Gears currently molds precision gears for medical and drug delivery devices. As a sub-tier supplier, Gleason is required to follow strict guidelines regarding the product and process validation for the supply of medical gears. In the product development arena, Gleason is typically involved in the design and development of the actual gear specifications and ultimately some of these specifications are included in the device's design history file (DHF). During the process validation, Gleason offers a variety of a la carte options for the execution of validation protocols and reports embracing the FDA's guidance related to installation qualification (IQ), operational qualification (OQ) and performance qualifications (PQ). In the end, these efforts ultimately define a process operating window that ensures the manufacturing process produces product that conforms to specifications!

Dengel: The primary certification for medical devices is ISO 13485:2016. This is a much stricter standard than the ISO 9001:2016 certification that many gear companies have obtained. A big difference between the standards that is driven by the difference in scope is the primary focus of the results. The general nature of and the industries that use ISO 9001:2015 are driven by customer focus and making the correct risk-based decisions to minimize the risk of customer dissatisfaction. Meanwhile, the focus of ISO 13485:2016 is primarily driven by the need for regulators to ensure that the medical devices placed on the market by organizations are safe and effective.

Given multi-discipline complexity in making these parts (e.g., design, material specification, sophisticated software, CNC machining, etc.), how "vertical" need a company be in order to compete in the medical device industry? For example, if a supplier is making gear motors for medical

devices, does that motor supplier also make the gears or contract them?

Diaz: Gleason offers a variety of options to address the complex needs of the medical device industry. From a design perspective, the recent acquisition of *KISSsoft* gear software enables us to participate in the early stages of the gear / gear train development process. From a prototyping perspective, Gleason offers early prototype supply leveraging additive manufacturing technologies as well as CNC direct machined samples. Gleason can supply medical device customers with individual gears or modular gearbox sub-assemblies containing motors. Ultimately, Gleason's goal is to design and validate a gear manufacturing solution that leverages Gleason's world class metrology core competencies at the lowest possible cost.

Following up on the above – are single-source suppliers the biggest players?

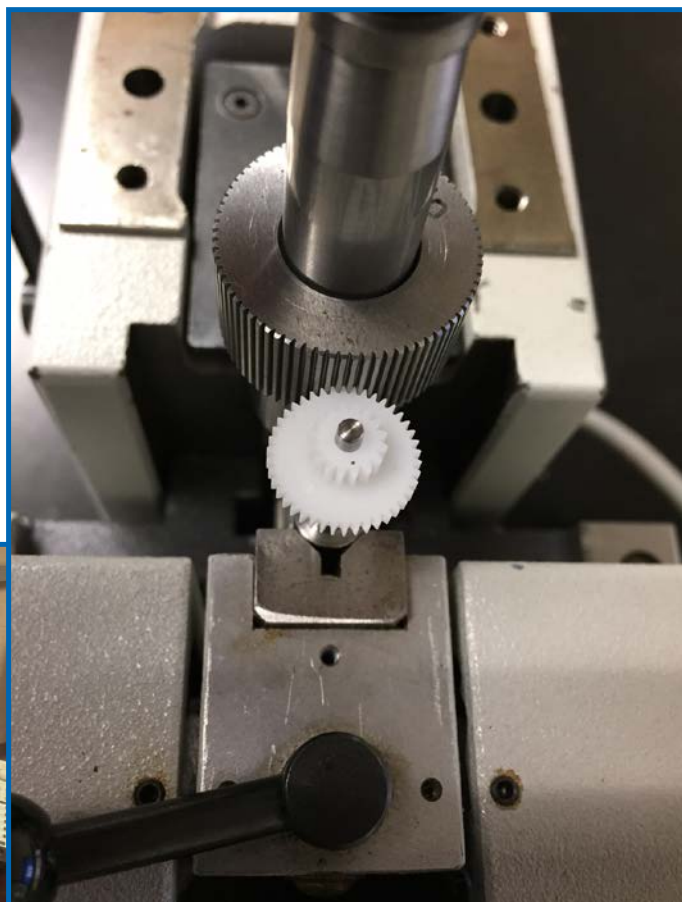
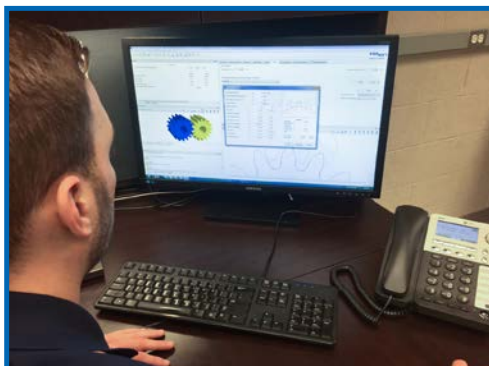

photos courtesy Gleason Plastic Gears.

Diaz: The medical device industry is a very complex, highly regulated industry that demands 100 percent safety and efficacy in product performance. Given the complex idiosyncrasies of gear technology, Gleason's approach is to support all medical device customers in need of gears regardless of the company's size.

What types of gears are typically used in medical devices?

Springer: Typically gears are kept as simple as possible, especially if the device is for one-time use only. Most designs start with a combination of spur gears, racks/pinions, and crossed-axis helical. Reducing the complexity of the gears will help reduce the costs, especially if the gears are injection molded or powder metal. It is important that during the design stage, the performance versus cost/manufacture-ability is weighed carefully.

Leveraging Gleason's 152 year gear technology heritage, Gleason Plastic Gears offers gear design support for the cylindrical and bevel world! We can design spur and helical gear solutions for parallel and cross axis applications. We also can support cycloidal and epi cycloidal solutions.

Are bearings typically involved? Both plastic and metal?

Diaz: The *KISSsoft/KISSsys* software (recently acquired by Gleason Company) offers the capability to model bearings within the suite of product solutions. Gleason Plastic Gears can support the use of various bearing solutions based on specific operating conditions.

What hurdles are there in achieving the precision required for medical devices?

Diaz: Gleason Plastic Gears no weldline technology enables us to deliver the highest gear quality level within the injection molding industry! Keeping the gears round, especially when using highly engineering resins, is a difficult task. It is important that the manufacturing process is laid out correctly, the tools are accurate, and that the proper gear metrology is used to ensure gear precision. If making metal gears with heat treatment requirements, understanding how to account for and to correct gear distortion due to heat treatment is critical. This is something Gleason specializes in, in both the metal and plastic worlds.

Is the Food and Drug Association (FDA) the primary "watch dog" for component manufacture?

Diaz: The FDA is responsible to ensure that all medical devices are safe and effective. At minimum, all finish goods medical device manufactures must meet FDA requirements based on the ISO 13485 guidelines.

Is the International Standards Organization (ISO) the only regulatory body (e.g. – ISO 13485:2003), or is AGMA involved as well? Comparing metal gear standards with plastic gear standards is like comparing apples to oranges, correct?

Dengel: AGMA does not have a standard for medical device components. The standards are based on the type of gearing, i.e. – spur gears, bevel gears, worm gears. The standards are also independent of material selection. An

AGMA 9 quality gear needs to meet the same dimensional specifications where it is made from aluminum, nylon or alloy steel.

Springer: The medical device guidelines are equally applicable to metal or plastic gears. Although the manufacturing processes are different between metal and plastic gears, the manufacturing process must be fully validated per the required medical specifications.

Where would you say the idea for a new medical device begins? With the surgeons/doctors? Design engineers? Elsewhere?

The requirement for a new medical device typically starts with the users and people most involved with its end use or need. When a need is recognized, it is trickled down to major players in the industry. If the desire for a new device is in high demand (and of course, if the dollars make sense), this triggers the medical device manufacturers to pursue a conceptual design phase in which product design and feasibility are kicked-off.

Are you coping with the scarcity of skilled personnel available for such quality-driven work? Or not a problem?

Diaz: Gleason's world-class heritage continuously attracts the best gearheads in the world. Our Gleason Plastic Gear Division (Rochester, NY) is always inundated with local skilled personnel interested in supporting our business needs. Our strong relationship with Rochester Institute of Technology's Kate Gleason School of Engineering enables us to recruit the best students within the school!

To what extent has the relatively recent "discovery" of mechatronics, along with the latest IIoT/industrial automation advances, affected the manufacture of medical device components?

Diaz: Medical Device manufactures are under significant pressures to produce defect-free products. The establishment of the Gleason Automation Systems Division has enabled our metal machining centers to become machining system solutions. Gleason can now offer highly integrated inline solutions involving the unique (marking) serialization of each part as well as the integration of a 100% online gear inspection system. These readily available machine options ensure that all critical gear dimensions meet the product specification. **PTE**

For more information:

The Gleason Works – Gleason Plastic Gears
8210 Buffalo Road, Bergen, NY 14416
Phone (office): (585) 494-2470
Cell: (585) 455-7542
Fax: (585) 494-2474

KHK-USA
259 Elm Place, Mineola, NY 11501
Phone: (516) 248-3850
Fax: (516) 248-4385
www.khkgears.us

For Related Articles Search

medical

at www.powertransmission.com



Over 32,000 standard components.

Buy online 24/7.

Nordex.com



Turner Uni-Drive

Manufacturers of Industrial Transmissions, Speed Reducers & Gearboxes

www.turnerunidrive.com



Catalog Multi-speed

Custom Design

OEM Manufacturing

- **Standard catalog and custom engineered gearboxes**
- **1 HP to 1000 HP**
- **Gearbox repair**
- **Reverse Engineering**

Turner Uni-Drive Phone: 816-931-6001 | Toll Free Phone: 800-637-7736
 3434 Terrace Street | Kansas City, MO 64111 Fax: 816-931-6055



B&R

MACHINE AND GEAR CORP

BRGEAR.COM



High Performance Bevel Gearboxes

The Tandler spiral bevel is ideal for precise motion control, high speed, high torque, or heavy shock.



- 9 sizes
- Low backlash
- 15 ratios
- Customizable

DIEQUA
Corporation

www.diequa.com

630-980-1133

Economical Helical Speed Reducers

The Varvel RD series provide heavy duty performance in a light-weight package.



- Diecast aluminum housing
- 5 sizes 0.25 - 25 HP
- NEMA or IEC dimensions
- Unique coupling input
- Interchangeable with competitors

DIEQUA
Corporation

www.diequa.com

630-980-1133

Engineering sMart

is your resource for the latest in great ideas from our advertisers. Check this section every issue for sMart Engineering ideas and technology.

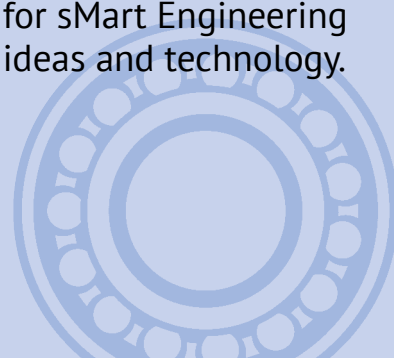

For information about advertising, contact Dave Friedman

at

(847) 437-6604

or

dave@powertransmission.com.

Power Transmission Engineering online!

It's like your own professional superpower.

Stronger, faster and smarter than your average website, www.powertransmission.com offers everything you need to supercharge your engineering-oriented organization.

- Complete archive of articles on engineered components
- Directory of suppliers of gears, bearings, motors and other mechanical power transmission components
- Product and Industry News updated daily
- Exclusive online content in our e-mail newsletters
- The Bearings Blog
- Calendar of upcoming events
- Comprehensive search feature helps you find what you're looking for — *faster than a speeding bullet!*



www.powertransmission.com

ISO/AGMA Standards — Specific Sliding Defined

THE QUESTION

Does the definition of specific sliding mean the same between ISO 21771:2007 and AGMA 917-B97? In ISO, specific sliding is the ratio of the sliding speed to the speed of a transverse profile in the direction of the tangent to the profile. In AGMA, specific sliding is ratio of gear tooth sliding velocity to its rolling velocity.

Expert response provided by Bob Errichello: AGMA 917-B97 Ref. 1) defines specific sliding as the ratio of gear tooth sliding velocity to rolling velocity, but it does not offer equations for calculating specific sliding. It recommends using profile shift to balance the specific sliding at each end of the path of contact to minimize wear of gear teeth, and cites Khiralla (Ref. 2) for calculation methods.

ISO 21771:2007 (Ref. 3) Eq. (114) and Eq. (115) define specific sliding, which agrees with the AGMA 917-B97 definition (note that in the ISO definition “speed of a transverse profile” is equivalent to “rolling velocity” in AGMA 917-B97). Furthermore, the ISO Eq (114) and Eq (115) are equivalent to Khiralla’s Eq (2-76) and Eq (2-77).

For more information on profile shift and specific sliding, see AGMA 901-A92 (Ref. 4), Annex A. It explains typical reasons for profile shift including:

- Avoiding undercut
- Balancing specific sliding
- Balancing flash temperature
- Balancing bending fatigue life
- Avoiding narrow top lands

References

1. AGMA 917-B97. *Design Manual for Parallel Shaft Fine-Pitch Gearing*, AGMA 1997.
2. Khiralla, T.W. *On the Geometry of External Involute Spur Gears*, Copyright 1976 by Tofa William Khiralla, printed by C/I Leaming, North Hollywood, California.
3. ISO 21771:2007(E). “Gears — Cylindrical Involute Gears and Gear Pairs — Concepts and Geometry,” ISO 2007.
4. AGMA 901-A92. “A Rational Procedure for the Preliminary Design of Minimum-Volume Gears,” AGMA 1992.

For Related Articles Search

gear design

at www.powertransmission.com



In a career spanning more than 40 years, **Robert Errichello** has earned a reputation for being the go-to person for instruction on gear failure analysis. Bob heads his own gear consulting firm, GEARTECH, and is founder of GEARTECH Software, Inc. He is a registered Professional Engineer who holds BS and MS degrees in Mechanical Engineering and a Master of Engineering degree in structural dynamics from the University of California at Berkeley. He is author of more than 60 articles on design, analysis, and application of gears, and has written three widely-used computer programs for the design and analysis of gears. He is a recipient of AGMA’s Lifetime Achievement Award in addition to other awards from AGMA, AWEA, and STLE. Students come from all over the world to attend his course, and AGMA is proud to be able to extend this learning experience to you. Last, but certainly not least, Bob is also a longtime Gear Technology magazine Technical Editor.



Hungry for More?



Everything you need if you buy gears, bearings, motors, couplings and clutches.

Power Transmission Engineering

- **Product and Industry News Updated Daily**
- **Directory of Mechanical Power Transmission Suppliers**
- **Exclusive online content in our e-mail newsletters**
- **Back Issues and Article Archive**
- **Calendar of Upcoming Events for power transmission professionals**

FREE SUBSCRIPTION!

www.powertransmission.com

A Major Step Forward in Life Modeling

Guillermo Morales-Espejel and Antonio Gabelli

The SKF Generalized Bearing Life Model is (GBLM) an innovative new bearing rating life model that is designed to help engineers calculate bearing rating life in a more realistic manner. The new model is a major step forward for the industry and will play an important role in enabling OEMs and end users to better match bearings and applications, resulting in improved machine life and reduced operating costs.

The fundamentals of the new model are presented here.

Up to now the estimation of rolling bearing life has relied on engineering models that consider an equivalent stress — originated beneath the contact surface — that is applied to the stressed volume of the rolling contact. Through the years, surface-originated fatigue resulting from reduced lubrication or contamination has been incorporated into the estimation of the bearing life by applying a penalty to the overall equivalent stress of the rolling contact. In the SKF GBLM this issue is addressed by developing a general approach for rolling contact life in which the surface-originated damage is explicitly formulated into the basic fatigue equations of the rolling contact. This new formulation supplies the power to better represent the tribology of rolling bearings in rating life calculations. Further, it gives a better knowledge of the surface endurance that dominates the field performance of rolling bearings. The ability of the present general method to account for the tribology and surface-subsurface competing fatigue mechanisms taking place in rolling bearings is discussed.

Modern rolling bearings have become increasingly reliable when correctly used and lubricated. This is due to good practices and the successful understanding and application of the traditional rolling contact fatigue mechanisms. Increased material cleanliness and good manufacturing quality, combined with reliable life-rating methods, have made this possible. However, industrial trends of downsizing and higher demands for efficiency in field performance keep imposing additional, severe conditions upon rolling bearings — especially on the contacting surfaces. This is why most bearing failures are surface-related (Ref. 1). In order to prevent rolling bearings from causing a bottleneck in furthering the performance increase of modern machinery, the tribology of bearing surfaces must be better assessed with respect to bearing performance. In the past decade SKF has made substantial progress in the surface life modeling area (Refs. 2–8). Finally, the integration of this knowledge into rolling bearing life rating has been made possible (Ref. 9) with the introduction of the SKF generalized bearing life model (GBLM). It separates surface from subsurface and thus different physical models can be applied for those two regions. Subsurface rolling contact fatigue can be treated in the usual way following the classic, dynamic capacity model of Lundberg and Palmgren (Ref. 10), while treatment of the surface requires more advanced tribological models that address the complex physi-

cal interactions occurring in highly stressed, concentrated Hertzian contacts (such as lubrication, friction, wear, fatigue or running-in).

This enables SKF to reflect, in its bearing life predictions, more customized designs with specific features that can impact the field performance of bearing applications. Examples of this are bearings with specific heat treatment, advanced microgeometry or of a particular design or quality.

Customers can take advantage of the unique features of SKF bearings that are available in the product catalogue and use them in rating life calculations. At the end of the day, customers will be able to better utilize the features and quality of SKF products that can't be represented simply by a single "sub-surface" dynamic load rating (C), as is done today (Ref. 11).

The ability of this new approach to deal specifically with the degradation mechanisms and tribology of the raceway surface will enable the use of a more advanced version of the GBLM in bearing product development.

SKF engineers will use the GBLM to develop improved bearing designs targeting special applications or particular field performance requirements. In short, the GBLM represents a modern and flexible bearing performance rating tool, one able to incorporate new knowledge and technologies as they are developed.

Generalized Modeling Approach

The present model will retain the standardized probabilistic approach used up to now in rolling bearing life ratings based on a two-parameter Weibull distribution (Ref. 12). Waloddi Weibull (Ref. 13), with his "weakest link" theory, introduced stochastic concepts in the determination of strength and rupture of structural elements.

If a structure composed of n elements is subjected to different stress states — thus with a different probability of survival S_1, S_2, \dots, S_n following the product law of reliability — the probability that the whole structure will survive is:

$$S_t^n = S_1 \cdot S_2 \cdots S_n = \prod_{i=1}^n S_i \quad (1)$$

Lundberg and Palmgren, in their classic original formulation of the basic dynamic load rating of rolling bearings (Ref. 10), applied the product law of reliability of Weibull (Eq. 1), to derive the survival function of a structure made of n — independent physical elements accounting for the degradation process from 0 to N load cycles:

$$\ln \left[\frac{1}{S(N)} \right] = \ln \left[\frac{1}{\Delta S_1(N)} \right] + \ln \left[\frac{1}{\Delta S_2(N)} \right] + \cdots + \ln \left[\frac{1}{\Delta S_n(N)} \right] \quad (2)$$

The volume V can be divided into two or more independent sources of damage risk for the structure; consider that G is a material degradation function accounting for the effect of the

accumulation of load cycles (fatigue). Therefore, regions can be characterized by different material degradation functions that could describe different (or a single) degradation processes $G_{v,1}, G_{v,2}, \dots, G_{v,n}$. Their combined effect on the survival of the complete structure can be expressed by using Equation 2. However, consider now only two regions, one for the subsurface (region v) and another for the surface (region s), from which the following can be derived:

$$\ln \left[\frac{1}{S(N)} \right] = \int_{V_v} G_v(N) dV_v + \hat{h} \int_{V_s} G_s(N) dA \quad (3)$$

Following Reference 14, the fatigue damage volume integral can be obtained by using the stress amplitude σ_v originated from the Hertzian stress field:

$$\int_{V_v} G_v(N) dV_v = \bar{A} N^e \int_{V_v} \frac{\langle \sigma_v - \sigma_{u,v} \rangle^c}{z^h} dV_v \quad (4)$$

Where c and h are exponents, e represents the Weibull slope for the subsurface, N is the contact life in number of load cycles, z represents the depth of analysis, V_v is the integration volume, $\sigma_{u,v}$ is the fatigue limit at the volume, and \bar{A} is a set-up constant.

In a similar manner one can rewrite the surface damage function. If the constant \hat{h} is included into the surface damage proportionality constant, one obtains:

$$\hat{h} \int_A G_s(N) dA = \bar{B} N^m \int_A \langle \sigma_s - \sigma_{u,s} \rangle^c dA \quad (5)$$

Here, m is the Weibull slope for the surface, A is the integration surface, $\sigma_{u,s}$ is the fatigue limit at the surface and is B a set-up constant.

In the surface damage Equation 5, the surface stresses σ_s must be obtained from the actual surface geometry of the contact and frictional stresses.

Now by combining Equations 4 and 5 with 3 it is possible to obtain a contact life equation with separate terms for the surface and the subsurface. Note that the life in number of revolutions can be related to the number of load cycles by $L = N/u$, where u is the number of load-cycles-per-revolution, and considering that the two Weibull slopes are very similar — $e = m$ — which is the case of the relevant surface failure modes in bearings, and finally leads to:

$$L_{1-s} = \frac{\left[\ln \left(\frac{1}{S} \right) \right]^{1/e}}{u} \left[\bar{A} \int_{V_v} \frac{\langle \sigma_v - \sigma_{u,v} \rangle^c}{z^h} dV_v + \bar{B} N^m \int_A \langle \sigma_s - \sigma_{u,s} \rangle^c dA \right]^{-1/e} \quad (6)$$

This represents the basis of a bearing life model that explicitly separates the surface from the sub-surface. The subsurface term, represented by the volume integral, can be solved in the same way as in Reference 14, with the use of traditional Hertzian rolling contact fatigue techniques. However, the surface term represented by the area integral now offers the

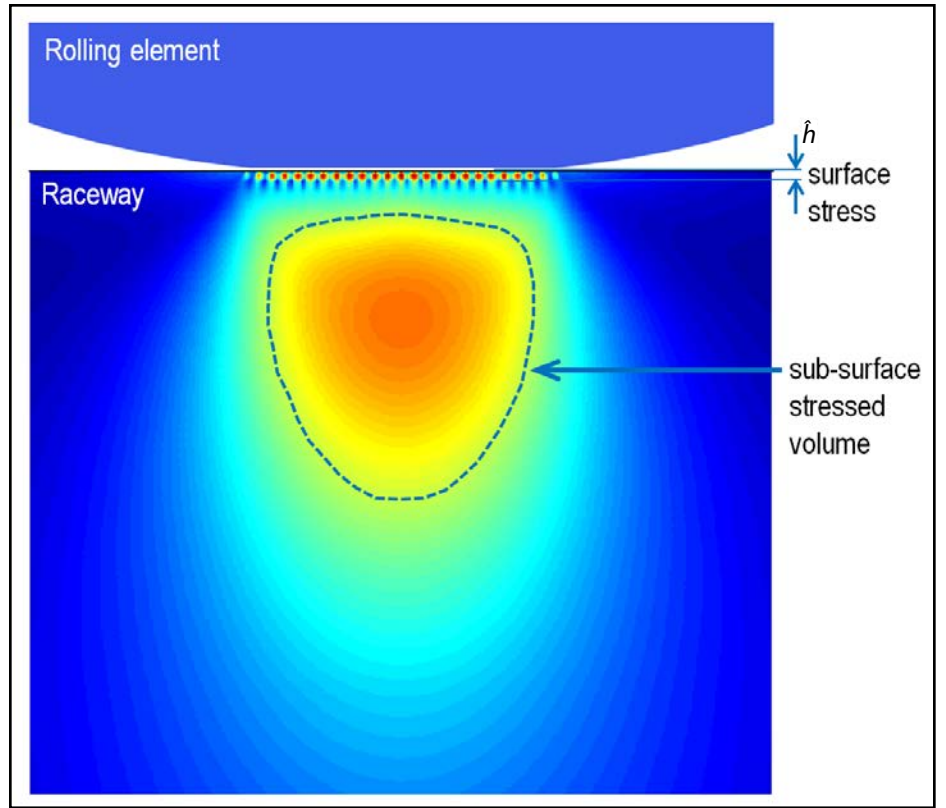

Figure 1 Separation of surface and subsurface as proposed by generalized bearing life model (GBLM).

possibility to consistently include in the model many of the tribological phenomena that characterize the endurance of the raceway surface.

Of course in this development the use of advanced numerical models is required. Indeed, it is required to represent complex interaction of competitive degradation mechanisms. For instance: i) surface fatigue in combination with mild wear; ii) indentation damage evolution; iii) tribochemical interactions; and many others. The schematic view of the GBLM main concept is represented in Figure 1.

Surface Models

A numerical surface distress model that combines fatigue and mild wear is described in (Ref. 5); this model requires as input the digitized surface roughness maps of the contacting surfaces (Fig. 2), and it solves the mixed-lubrication elastohydrodynamic problem (with non-Newtonian rheology).

$$R_s = f_i \exp \left[\frac{f_2}{(P/P_u)^{f_3}} + \frac{f_4}{(P/P_u)^{f_5}} \right] \quad (7)$$

The solution is performed in time steps for calculated pressures and stresses. The calculation model applies a damage criterion and a wear model to update the surface topography and proceed to the next calculation time step until a complete over-rolling load cycle is completed. This numerical process is repeated millions of times for all calculation points of the surface. This enables a good simulation of the physical phenomena of the wear/fatigue damage accumulation process on the raceway surface for each given number of over-rollings. Typical results of this numerical model are shown (Fig. 3) and are compared with experimental results of tests

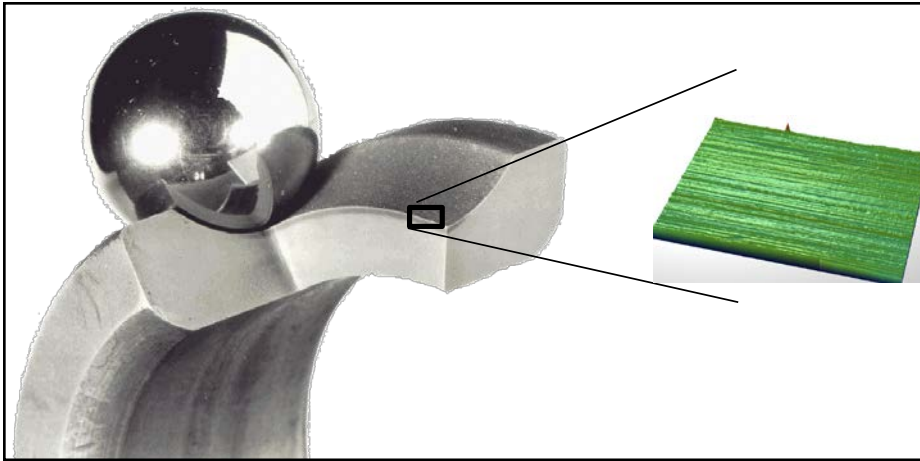

Figure 2 Bearing raceway roughness digitization using optical profilometer for 3-D surface mapping.

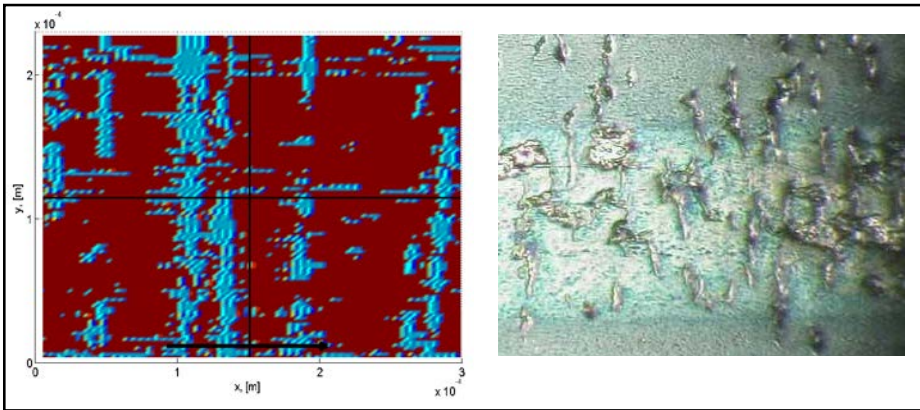

Figure 3 Typical results from the advanced surface distress (Ref. 5).

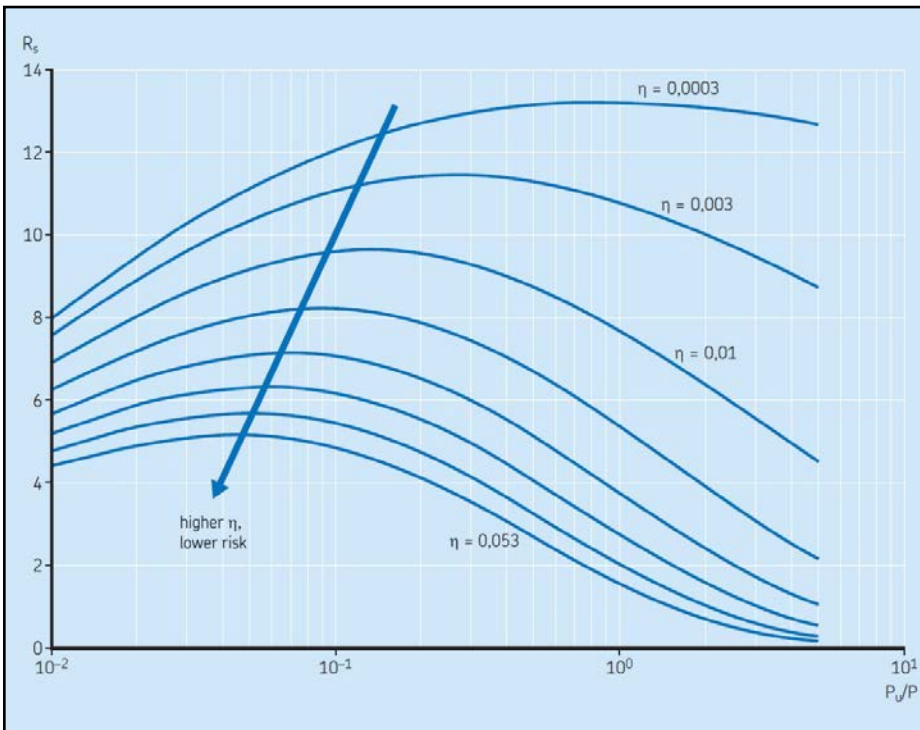

Figure 4 Example of surface risk rating as function of load and lubrication contamination regimes.

performed under the same conditions of the numerical simulation.

Other surface models that can be used with results integrated in GBLM are (Refs. 3, 6–7). As an example of the flexibility of the GBLM to integrate advanced surface damage models, for clarity only the surface distress model described in (Ref. 5) is considered. This model was used to run a parametric study using different operating conditions, roughness from different bearing types and sizes, and different lubrication and contamination regimes (Ref. 9). With this parametric study, the surface fatigue integral was normalized and curve-fitted to the following function using bearing parameters (Eq. 7)

Here, f_1, f_2, \dots, f_5 are constants, P is the equivalent dynamic bearing load, and P_u is the fatigue load limit of the bearing. The parameter R_s represents a surface damage risk rating; i.e. — it is a measure of the stresses imposed at the bearing running surfaces.

By using the advanced surface distress model, different lubrication and contamination conditions of the bearing can be computed, and their effect on the surface survival probability derived. In this way, by introducing the parameter $\eta = \eta_b \eta_c$ (Ref. 3) (to indicate the higher or lower risk of surface interaction), one can obtain a representation of Equation 7 as function of the dimensionless equivalent load P_u/P for a particular bearing type (Fig. 4).

Performance Factors

Unique design features of SKF bearings can eventually be taken into account using the above-discussed methodology to derive specifically designed “performance factors.” These factors could be developed to give a better account of the performance of particular design features and specific operating conditions.

Typically these performance factors will apply to surface performance resulting, for instance, from novel heat treatments or materials resulting in improved raceway hardness, use of coating, introduction of improved raceway micro-geometry and surface finishing. However, the use of specific performance factors could in future also cover subsurface and even particular aspects

of lubricants or lubrication. Basically, the structure of the GBLM enables the consistent incorporation of new bearing technologies and related performance prediction knowledge as they become available.

As an example of a performance factor related to the survival probability of the raceway surface, one can consider the introduction of bearing raceways with improved hardness, i.e. — better resistance to wear and contamination, particularly under reduced lubrication conditions. The knowledge of the expected improved performance of the surface endurance can be a factor in Equation 7, using a performance factor that reduces the surface damage risk (Fig. 5).

Notice that in this particular case the performance factor was developed to target only a certain region of the operating conditions of the bearing. As shown (Fig. 5), the more significant surface risk rating reduction happens in the area of high risk for the surface; as the parameter η increases and the risk is reduced, the influence of the performance factor is also reduced. This shows the ability of this GBLM performance factor to target specifically the poor lubrication or high contamination levels of the bearing condition in which the more significant reduction of the surface survival risk is expected.

Normalized Surface Risk

Since the GBLM is able to separate the surface and subsurface endurance terms, it is possible to weight their relative impact to the overall dynamic performance of the bearing.

For instance, by introducing: i) the normalized surface integral or surface damage risk R_s ; ii) the normalized subsurface stress integral or subsurface damage risk R_{ss} ; and iii) the scaling coefficient c , one can derive the normalized surface risk of a bearing that is:

$$S_r = \frac{cR_s}{R_{ss}} \quad (8)$$

This parameter can vary from 0 to 1. When it is close to 1 the weight of fatigue on the surface is dominant in respect to the subsurface; when it is close to 0 the opposite is true. This is an important parameter in order to understand which stress area of the bearing carries higher risk. With this information application engineers and customers can plan corrective measures to maximize bearing performance and reduce costs.

Model Validation

When the operating conditions are similar, the GBLM gives results that are consistent with the current SKF life rating, and also to a large extent to the ISO 281 life rating models. This is

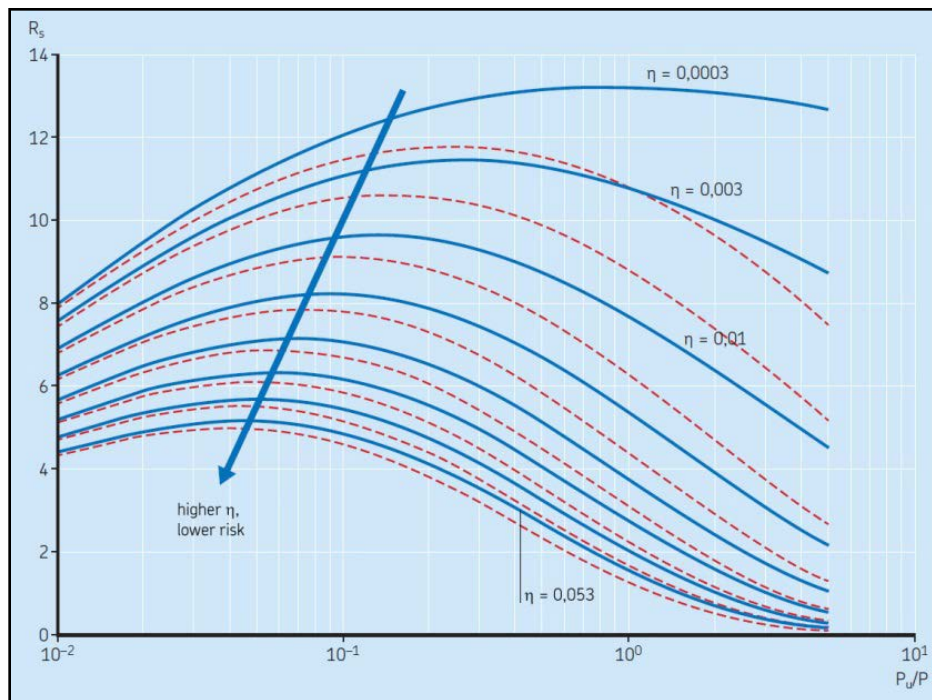

Figure 5 Example of surface risk rating as function of load and lubrication and contamination regimes; red dashed lines show effect of performance factor resulting from introduction of heat treatment that produces improved hardness of raceway surface.

because the GBLM has been validated against the extensive SKF database of endurance test results. This database is constantly increased and updated to follow new bearing technology development.

The introduction of performance factors will eventually alter the life that is predicted. However, this is a consequence of the performance modifications introduced by new bearing design aspects, which now will be visible in the rating life. In all cases SKF ensures that bearing performance changes are backed up by properly conducted endurance tests.

Customer Benefits with the GBLM

Customers can take significant advantage of the introduction of the GBLM in bearing life rating. Indeed, the calculation of the expected endurance performance of the bearing will be supplemented by knowledge of the surface risk of the application. In case the application condition of the bearing results in a predominant risk for the surface, corrective measures can be taken and their effect on the surface survival risk can be quantified. In other words, the GBLM can provide a diagnostic tool to improve field performance of the bearing by reducing surface-originated failures.

In general a high risk for the surface resulting from reduced lubrication and increased contamination cannot be resolved by adopting a bearing with an increased dynamic load rating and bearing size. This can be quickly checked by the effect of increased load rating and bearing size on the normalized surface risk. Therefore, customers can benefit from the use of the GBLM by making a more informed selection of the bearing, the surrounding components, and lubrication system for maximization of performance and reduction of the overall cost of the application.

Summary and Conclusions

A more flexible way to express bearing life — by splitting explicitly the terms related to surface failure modes from the general subsurface rolling contact fatigue terms — has been presented with the introduction of the SKF generalized bearing life model (GBLM). This model introduces the use of performance factors and makes possible targeting specific bearing features and more customized designs or applications. The model, apart from estimating the rating life of bearings, also calculates a normalized surface risk value S_R to give a clear indication of the surface fatigue weight in comparison to the subsurface one.

In general, the following conclusions can be made:

The new SKF generalized bearing life model (GBLM) provides a clear split between terms affecting the surface and terms affecting the subsurface, and can be explained as a more flexible way to express the current SKF life rating.

This model is the only existing bearing life model able to explicitly contain separate subsurface and surface-related terms in its formulation, incorporating easily the knowledge gained with the use of advanced numerical tribology models.

Novel elements in the model are the performance factors to account for specific SKF proprietary design improvements in the bearing, and/or design features affecting the performance of the bearing in an application in targeted operating conditions.

The GBLM can be regarded as a platform of models that can be grown as new knowledge is developed, enabling easy incorporation with the consideration of different phenomena affecting specifically the surface or the subsurface areas in the bearings.

The SKF generalized bearing life model will be available for customers in the near future. **PTE**

References

- Gläntz, W. "Contamination in Lubrication Systems for Bearings in Industrial Gearboxes," *Ball Bearing Journal*, 242, pp. 20-26, 1993.
- Morales-Espejel, G.E., A. Gabelli and E. Ioannides. "Microgeometry Lubrication and Life Ratings of Rolling Bearings," *Proc. IMechE, Part C, J. of Mech. Eng. Sci.*, Vol. 224, pp. 2610-2626, 2010.
- Gabelli, A., G.E. Morales-Espejel and E. Ioannides. "Particle Damage in Hertzian Contacts and Life Ratings of Rolling Bearings," *Trib. Trans.*, 51, pp. 428-445, 2008.
- Morales-Espejel, G.E., A. Gabelli and E. Ioannides. "Microgeometry Lubrication and Life Ratings of Rolling Bearings," *Proc. IMechE, 224, Part C: J. of Mech. Eng. Sci.*, pp. 2610-2626, 2010.
- Morales-Espejel, G.E. and V. Brizmer. "Micropitting Modelling in Rolling-Sliding Contacts: Application to Rolling Bearings," *Trib. Trans.*, 54, pp. 625-643, 2011.
- Morales-Espejel, G.E. and A. Gabelli. "The Behavior of Indentation Marks in Rolling-Sliding Elastohydrodynamically Lubricated Contacts," *Trib. Trans.* 54, pp. 589-606, 2011.
- Brizmer, V., H.R. Pasaribu and G.E. Morales-Espejel. "Micropitting Performance of Oil Additives in Lubricated Rolling Contacts," *Trib. Trans.*, 56, pp. 739-748, 2013.
- Morales-Espejel, G.E. and A. Gabelli. "The Progression of Surface Rolling Contact Fatigue Damage of Rolling Bearings with Artificial Dents," *Trib. Trans.* 58, pp. 418-431, 2015.
- Morales-Espejel, G.E., A. Gabelli and A. de Vries. "A Model for Rolling Bearing Life with Surface and Subsurface Survival - Tribological Effects," *Tribology Transactions*, Volume 58, Issue 5, 2015.
- Lundberg, G. and A. Palmgren. "Dynamic Capacity of Rolling Bearings," *Acta Polytechnica, Mec. Eng. Ser.*, 1(3), pp. 1-52, 1947.
- Gabelli, A., A.L. Doyer and G.E. Morales-Espejel. The Modified Life Rating of Rolling Bearings – A Criterion for Gearbox Design and Reliability Optimization," AGMA Technical paper 14FTM16, ISBN: 978-1-61481-108-4, 2014.
- Blachère, S. and A. Gabelli. "Monte Carlo Comparison of Weibull Two and Three Parameters in the Context of the Statistical Analysis of Rolling Bearings Fatigue Testing," STP 1548, J. Beswick, Ed., pp. 126, STP104519, ASTM Int., West Conshohocken, PA 2012.
- Weibull, W. "A Statistical Theory of Strength of Materials," IVA Handlingar No. 151, *Proc. Roy. Swed. Acad. of Eng. Sci.*, pp. 1-45, 1939.
- Ioannides, E. and T.A. Harris. "A New Life Model for Rolling Bearings," *ASME, J. of Trib.*, Vol. 107, pp. 367-378, 1985.

For Related Articles Search

bearing life

at www.powertransmission.com



Guillermo E. Morales-Espejel, principal scientist for SKF Engineering & Research Centre, The Netherlands, and Visiting Professor at LaMCoS, INSA de Lyon, France, holds a PhD in tribology from the University of Cambridge, U.K., and a "Habilitation à Diriger des Recherches (INSA-Lyon)." Along with his 10 years of university lecture presentations, he possesses 15 years of experience in rolling bearings. Morales-Espejel is author of more than 50 scientific papers and several book chapters; his primary scientific interests are bearing life, friction, lubrication and surface life.



Antonio Gabelli is senior scientist working at SKF on tribology and rolling contact fatigue life of rolling bearings. He joined the Engineering and Research Center of SKF in Netherlands in 1981, since then he published many research papers on fatigue and lubrication of rolling bearings. He was one of the key contributors to the new bearing life theory, developed by SKF in the 90's. He is also author of several patents on rolling bearings. He holds a mechanical engineering degree from the University of Padua (Italy) and a Ph.D degree in from Chalmers Technical University of Gothenburg (Sweden).



GREAT SCOTT!

It's the future!

OK, you blinked and missed last month's issue of *Power Transmission Engineering*. Fortunately, you don't need a DeLorean to travel back in time — just a computer and working fingers.

Hop online and visit www.powertransmission.com to view the entire magazine, including these exclusive features:

- Getting a Piece of that Sweet Coupling Pie
- The Small Motor Rule — How Will it Affect You?
- Ask the Expert — Pre-tension Thrust Bearings
- Applications of Bevel Gears

...and much more!

www.powertransmission.com

Baldor Basics: Motors

Edward Cowern, P.E.

A continuing series of articles, courtesy of the Baldor Electric Co., dedicated primarily to motor basics; e.g. — how to specify them; how to operate them; how — and when — to repair or replace them, and considerably more. Stay tuned!

THIS ISSUE:

Motor Temperature Ratings
Metric Motors

Motor Temperature Ratings

A frequently misunderstood subject related to electric motors is insulation class and temperature ratings. This paper tries to describe, in basic terms, the temperature relationships that are meaningful in standard AC induction motors. Some of the same information can be applied to DC motors but DC motors are more specialized and some of the ratings are slightly different. *Perhaps the best way to start is to define the commonly used terms.*

Definitions

Ambient temperature. Ambient temperature is the temperature of the air surrounding the motor or the room temperature in the vicinity of the motor. This is the “threshold point” or temperature that the entire motor would assume when it is shut off and completely cool.

Temperature rise. Temperature rise is the *change* in temperature of the critical electrical parts within a motor when it is being operated at full load. For example: if a motor is located in a room with a temperature of 78° F, and then is started and operated continuously *at full load*, the winding temperature would rise from 78° F to a higher temperature. The difference between its starting temperature and the final elevated temperature, is the motor’s *temperature rise*.

Hot-spot allowance. Since the most common method of measuring “temperature rise” of a motor involves taking the difference between the cold and hot ohmic resistance of the motor winding (see *Appendix for formula to determine temperature rise by resistance*), this test gives the *average* temperature change of the entire winding including the motor leads and end turns, as well as wire placed deep inside the stator slots. Since some of these spots are bound to be hotter than others, an allowance factor is made to “fudge” the average temperature to give a reflection of what the temperature might be at the hottest spot. This allowance factor is called the “hot spot allowance.”

Insulation class. Insulations have been standardized and graded by their resistance to thermal aging and failure. Four insulation classes are in common use. For simplicity, they have been designated by the letters A, B, F, and H. The temperature capabilities of these classes are separated from each other by 25° C increments. The temperature capabilities of each insulation class are defined as being the maximum temperature at which the insulation can be operated to yield an average life of 20,000 hours. The rating for 20,000 hours of average insulation life is as shown below.

Insulation Class	Temperature Rating
A	105° C
B	130° C
F	155° C
H	180° C

Insulation system. There are a number of insulating components used in the process of building motors. The obvious ones are the enamel coating on the magnet wire and the insulation on the leads that come to the conduit box. Some less obvious components of the “system” are the sleeving that is used over joints where leads connect to the magnet wire, and the lacing string that is used to bind the end turns of the motor. Other components are the slot liners that are used in the stator laminations to protect the wire from chafing. Also, top sticks are used to hold the wire down in place inside the stator slots. Another important component of the system is the varnish in which the completed assembly is dipped prior to being baked. The dipping varnish serves the purpose of sealing nicks or scratches that may occur during the winding process. The varnish also binds the entire winding together into a solid mass so that it does not vibrate and chafe when subjected to the high magnetic forces that exist in the motor. Much like a chain that is only as strong as its weakest link, the classification of an insulation system is based on the temperature rating of the lowest rated component used in the system. For example, if one Class B component is used along with F and H components, the entire system must be called Class B.

Putting It All Together

Now that the basic terms have been identified, we can move on to understand the total picture and how the factors of temperature go together in the motor rating.

The basic ambient temperature rating point of nearly all electric motors is 40° C. This means that a motor, rated for 40° C ambient, is suitable for installation in applications where the normal surrounding air temperature does not exceed 40° C. This is approximately 104° F — a *very* warm room. This is the starting point.

When the motor is operated at full load, it has a certain amount of temperature rise. The amount of temperature rise is *always additive* to the ambient temperature. For example, U frame motors were designed for Class A insulation and a maximum temperature rise by resistance of 55° C. When operated in a 40° C ambient temperature, this would give a total average winding temperature of 40° (ambient) + 55° (rise) or 95° C. The ten degree difference between 95° C and the 105° C

rating of Class A insulation is used to handle the “hot spot allowance”. Now, if you use the same motor design but change the system to Class B, there is an extra 25° C of thermal capability available. This extra thermal capability can be used to handle:

- Higher than normal ambient temperatures
- Higher than normal temperature rise brought on by overloads
- Extra capability can be used to extend motor life and make it more tolerant of overheating factors caused by high or low voltages; voltage imbalance; blocked ventilation; high inertia loads; frequent starts; and any other factors that can produce above-normal operating temperatures.

For example: if a motor with Class A “design” (55° C) temperature rise is built with Class B insulation, then it could be expected to give a normal insulation life, even when subjected to ambient temperatures of 65° C. Most “T” frame motors are designed for use with Class B insulation. In a “T” frame motor with Class B insulation, the extra 25° of thermal capacity (Class B compared to Class A), is utilized to accommodate the higher temperature rise associated with the physically smaller “T” frame motors. For example: a standard T frame, open drip-proof motor might have the following rating: 40° C ambient, 80° C temperature rise, and a 10° hot spot allowance. When these three components are added together you will find that the total temperature capability of Class B insulation (130° C) is used up.

Changing insulation classes. By taking a Class B, totally enclosed fan cooled, T frame motor, and building it with Class F insulation, it is usually possible to increase the service factor from 1.0 to 1.15. As mentioned previously, this same change of one insulation class can be used to handle a higher ambient temperature or to increase the life expectancy of the motor. The same change could also make the motor more suitable for operation in high elevations where thinner air has a less cooling effect.

Actual insulating practice. Over the years, great improvements have been made in insulating materials. With these improvements have come cost reductions. As a result of these changes, most motor manufacturers use a mixture of materials in their motors, many of which have higher than required temperature ratings. For example, Baldor does not use Class A materials. This means that even though many fractional horsepower motors are designed for Class A temperature rise, the real insulation is Class B or better. Similarly, many motors designed for Class B temperature rise actually have insulation systems utilizing Class F and H materials. This extra margin gives the motor a “life bonus.” At the present time Baldor has standardized an ISR (inverter spike-resistant) magnet wire in all three phase motors 1 HP and larger. This wire has a Class H temperature rating and excellent resistance to high voltage spikes.

As a rule, insulation life will be doubled for each 10 degrees of *unused* insulation temperature capability. For example: if a motor is designed to have a total temperature of 110° C (including ambient, rise, and hot spot allowance), and is built

with a Class B (130° C) system, an unused capacity of 20° C would exist. This extra margin would raise the expected motor insulation life from 20,000 hours to 80,000 hours. Similarly, if a motor is not loaded to full capacity its temperature rise will be lower. This automatically makes the total temperature lower and extends motor life. Also, if the motor is operated in a lower than 40° C ambient temperature, motor life will be extended.

The same “ten degree rule” also applies to motors operating at above-rated temperatures. In such cases insulation life is “halved” for each 10° C of over-temperature.

Motor surface temperatures. Motor surface temperature is frequently a concern. The motor surface temperature will never exceed the internal temperature of the motor. However, depending upon the design and cooling arrangements in the motor, motor surface temperature in modern motors can be high enough to be very uncomfortable to the touch. Surface temperatures of 75° to 95° C can be found on T frame motor designs. These temperatures do not necessarily indicate overload or impending motor failure.

Other factors. Insulation life is affected by many factors aside from temperature. Moisture, chemicals, oil, vibration, fungus growth, abrasive particles, and mechanical abrasion created by frequent starts — all work to shorten insulation life. On some applications, if the operating environment and motor load conditions can be properly defined, suitable means of winding protection can be provided to obtain reasonable motor life despite external, disturbing factors.

Old and current standards. U frame 184 through 445U frames were designed based on using Class A insulation. Temperature rise was not precisely defined by the resistance method. Temperature rise by thermometer for Class A, open drip-proof motors was 40° C. This was generally thought to be equivalent to approximately 50° C by resistance. U frame motors were the industry standard from 1954 to 1965 and are still preferred in some industries and plants. T frame, 143T through 449T motors are generally designed based on using Class B insulation with temperature rises by resistance of approximately 80° C. Production of T frame motors started in the mid-sixties and they continue to be the industry standard at this time.

Table 1 Temperature ratings, temperature rise allowances and hot-spot allowances for various enclosures and service factors of standard motors

Insulation System Class	A	B	F	H
Temperature Rating in Degrees Centigrade	105°	130°	155°	180°
Temperature Rise Allowance by Resistance (Based on 40° C Ambient Temperature)				
All Motors with 1.15 Service Factor (Hot Spot Allowance)	70 *	90 *	115 *	— *
Totally Enclosed Fan Cooled Motors (Hot Spot Allowance)	60 (5)	80 (10)	105 (10)	125 (15)
Totally Enclosed Non-Ventilated Motors (Hot Spot Allowance)	65 (0)	85 (5)	110 (5)	135 (5)
Motors other than those listed above (Hot Spot Allowance)	60 (5)	80 (10)	105 (10)	125 (15)

* When operating at service factor loading the hot spot temperatures can actually exceed the insulation rating resulting in shortened motor life.

Table 2 Temperature-related, life-shortening factors — with symptoms and cures

Temperature Related Life-Shortening Factors		
PROBLEMS	SYMPTOMS	CURES
Low Voltage	Overload Tripping High current Short motor life	Correct power supply or match motor to actual power supply voltage rating.
High Voltage	Overload tripping High current Short Motor Life	Correct power supply or match motor to actual power supply voltage rating
Unbalanced Voltage	Unbalanced phase currents Overload tripping	Determine why voltages are unbalanced and correct.
Overload	Overload tripping High current Short motor life	Determine reason for overload. Increase motor size or decrease load speed.
High Ambient Temperatures	Short motor life	* Rewind motor to higher class of insulation. Oversize motor to reduce temperature rise. Ventilate area to reduce ambient temperature.
Blocked Ventilation	Short motor life Runs hot Amperage o.k.	Clean lint and debris from air passageways or use proper motor enclosure for application.
Frequent Starts	Short motor life	** Use a reduced voltage starting method. Upgrade class of insulation.
High Inertia Loads	Short motor life Overload tripping during starting	Oversize motor frame Use higher class of insulation. ** Use a reduced voltage starting method.

* Bearing lubrication must also be matched to high operating temperature.

** Reduced voltage starting method and motor characteristics must be matched to the load requirement.

Summary

A key ingredient in motor life is the insulation system used in the motor. Aside from vibration, moisture, chemicals, and other non-temperature related life-shortening items, the key to insulation and motor life is the maximum temperature that the insulation system experiences and the temperature capabilities of the system components (see Tables 1 and 2).

Appendix

Temperature Rise by Resistance Method

$$\text{Degrees C Rise} = \frac{R_h - R_c}{R_c} (234.5 + T)$$

Where

R_c = Cold winding resistance (Ohms)

R_h = Hot winding resistance (Ohms)

T = Cold (ambient) temperature in degrees (Centigrade)

Note: This formula assumes that the ambient temperature does not change during the test.

Example: A small motor has a cold temperature resistance of 3.2 ohms at 25° C (77° F) ambient temperature. After operating at full load for several hours the resistance measures 4.1 ohms, and the ambient has increased to 28° C.

Calculate the temperature rise:

$$\text{Apparent rise} = \frac{4.1 - 3.2}{3.2} (234.5 + 25) = 73^\circ \text{C}$$

Correcting for 3° C increase in ambient:

$$\text{Actual rise} = 73^\circ - 3^\circ = 70^\circ \text{C}$$

Centigrade Fahrenheit Conversions (Actual Temperatures)

To change Fahrenheit to Centigrade:

$$C^\circ = (F^\circ - 32) \times \frac{5}{9}$$

To change Centigrade to Fahrenheit:

$$F^\circ = (C^\circ \times \frac{9}{5}) + 32$$

Rise values only:

Degrees "C" rise = ° F (Rise) × .56

Degrees "F" rise = ° C (Rise) × 1.8

Metric Motors

The influx of foreign equipment have put great numbers of metric motors in plants. As a result of this and the age of these motors, we are seeing inquiries for replacement motors that will match the IEC (International Electrical Commission) standards.

To help identify these motors and make suitable replacements, the following information could be useful.

Rating system. One of the first things is that ratings are given in kilowatts (KW) rather than horsepower. The first thing to do is to convert from kilowatts to horsepower. It is important to note that even though KW is an electrical term, in this case it is associated with mechanical output (just as horsepower is in this country). A simple factor will make the conversion. *Multiply the KW rating of the motor by 1.34 to get the horsepower of the motor.* For example, a 2 KW motor would be equal to approximately 2.7 HP and the closest NEMA equivalent would be 3 HP.

The next item of concern would be the speed of the motor. Generally, somewhere on the nameplate of the foreign motor, you find the speed listed in RPM. The convention in Europe seems to be to show the no load speed of the motor and occasionally, the 50 cycle speed may be shown rather than the 60 cycle speed. Table 3 shows a crossover from the 50 cycle speeds to the equivalent 60 cycle speeds. In some cases, both the 50 and 60 cycle speeds are shown generally separated with a slash, for example, 1,500/1,800 RPM. This would be a 4 pole motor that U. S. manufacturers would show nameplated with its full load speed. In this case it might be 1725 to 1760 RPM depending on the size of the motor.

Efficiency. IEC 60034-30 specifies the efficiency levels for metric 50 Hz motors. The equivalent to our EPAct level of energy efficient motors (NEMA MG 1, table 12-11) is IE2; and premium efficient motors (NEMA MG 1, table 12-12) are IE3. Baldor manufactures metric motors to both levels. A new IEC

Table 3 Crossover from 50 cycle speeds to equivalent 60 cycle speeds

POLES	FREQUENCY			
	50 HZ SPEEDS (RPM)		60 HZ SPEEDS (RPM)	
	SYNCHRONOUS	FULL LOAD (Typical)	SYNCHRONOUS	FULL LOAD (Typical)
2	3000	2850	3600	3450
4	1500	1425	1800	1725
6	1000	950	1200	1150
8	750	700	900	850

Table 4 Typical metric foot mounted dimensions frame sizes for rigid-base motors and associated metric dimensions (dimensions are in millimeters — divide by 25.4 to get inch equivalents)

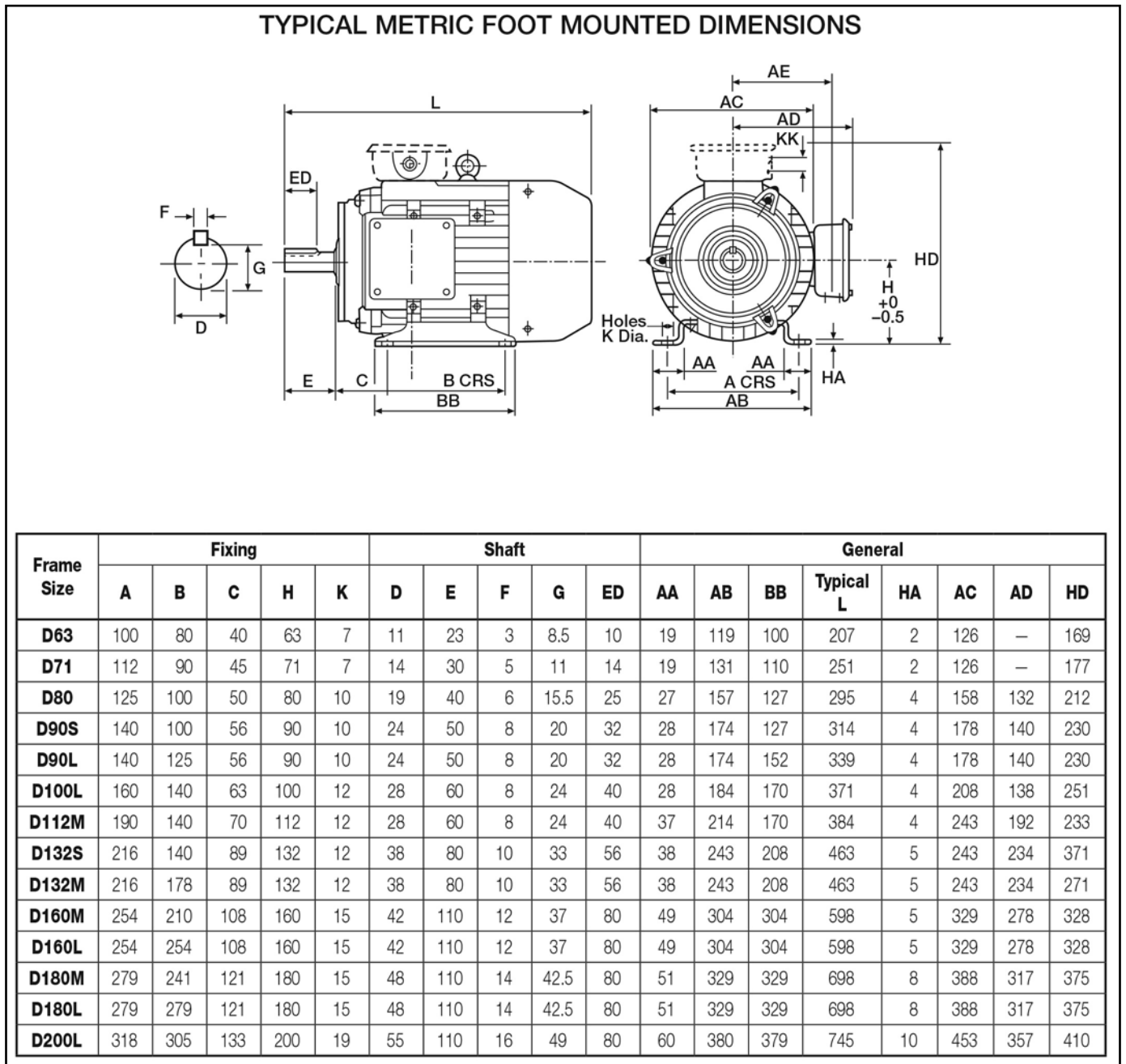
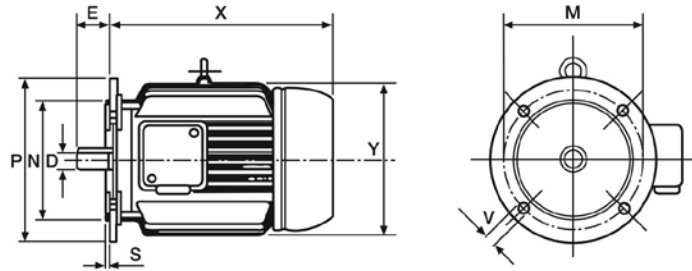

Table 5 Typical metric flange-mounted motor dimensions (note that dimensions are given in millimeters)

TYPICAL METRIC FLANGE MOUNTED MOTOR DIMENSIONS

B5



MOTOR SIZE	2 POLES		4 POLES		6 POLES		D	E	N	M	P	S	V	TYPICAL X	Y
	HP	KW	HP	KW	HP	KW									
56 A	0.12	0.09	0.08	0.06	—	—	9	20	80	100	120	2.5	7	167	102
56 B	0.16	0.12	0.12	0.09	—	—									
63 A	0.25	0.18	0.16	0.12	—	—	11	23	95	115	140	3	9	185	122
63 B	0.33	0.25	0.25	0.18	—	—									
71 A	0.5	0.37	0.33	0.25	0.25	0.18	14	30	110	130	160	3.5	9	211	140
71 B	0.75	0.55	0.5	0.37	0.33	0.25									
80 A	1	0.75	0.75	0.55	0.5	0.37	19	40	130	165	200	3.5	11	231	164
80 B	1.5	1.1	1	0.75	0.75	0.55									
90 S	2	1.5	1.5	1.1	1	0.75								245	
90 L	3	2.2	2	1.5	1.5	1.1	24	50	130	165	200	3.5	11	270	181
90 LL	—	—	2.5	1.8	—	—								292	
100 LA	4	3	3	2.2	2	1.5								304	
100 LB	—	—	4	3	—	—	28	60	180	215	250	4	14	304	207
112 M	5.5	4	5.5	4	3	2.2								343	
132 S	7.5-10	5.5-7.5	7.5	5.5	4	3								364	
132 M	12.5	9	10	7.5	5.5-7.5	4-5.5	38	80	230	265	300	4	14	402	259
132 L	—	—	12.5	9	—	—								402	
160 M	15-20	11-15	15	11	10	7.5	42	110	250	300	350	5	18	540	335
160 L	25	18.5	20	15	15	11									
180 M	30	22	25	18.5	—	—	48	110	250	300	350	5	18	600	374
180 L	35	26	30	22	20	15									
200 L	40-50	30-37	40	30	25-30	18.5-22	55	110	300	350	400	5	18	656	416
225 S	—	—	50	37	—	—	*60	140	350	400	450	5	18	680	416
225 M	60	45	60	45	40	30									
250 M	75	55	75	55	50	37	*65	140	450	500	550	5	18	742	490
280 S	100	75	100	75	60	45	*75	140	450	500	550	5	18	892	490
280 M	125	90	125	90	75	55									

* For 2 poles motors: Gr. 225 D = 55; E = 110 Gr. 250 D = 60; E = 140 Gr. 280 D = 65; E = 140

B14

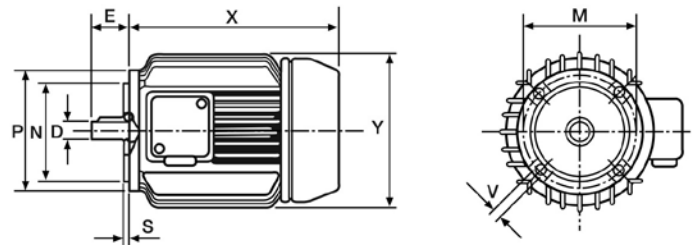

MOTOR SIZE	2 POLE		4 POLE		6 POLE		D	E	N	M	P	S	V	TYPICAL X	Y
	HP	KW	HP	KW	HP	KW									
63 A	0.25	0.18	0.16	0.12	—	—	11	23	60	75	90	2.5	M5	185	122
63 B	0.33	0.25	0.25	0.18	—	—									
71 A	0.5	0.37	0.33	0.25	0.25	0.18	14	30	70	85	105	2.5	M6	211	140
71 B	0.75	0.55	0.5	0.37	0.33	0.25									
80 A	1	0.75	0.75	0.55	0.5	0.37	19	40	80	100	120	3	M6	231	164
80 B	1.5	1.1	1	0.75	0.75	0.55									
90 S	2	1.5	1.5	1.1	1	0.75								245	
90 L	3	2.2	2	1.5	1.5	1.1	24	50	95	115	140	3	M8	270	181
90 LL	—	—	2.5	1.8	—	—								292	
100 LA	4	3	3	2.2	2	1.5								304	207
100 LB	—	—	4	3	—	—	28	60	110	130	160	3.5	M8	304	207
112 M	5.5	4	5.5	4	3	2.2	28	60	110	130	160	3.5	M8	343	207

60034-2-1 test method now measures all losses and is equivalent to IEEE 112b and CSA 390.

Failure replacement. When an IEC (metric) motor fails in service the most practical way to proceed is to attempt to get an exact metric framed replacement motor. Baldor and other manufacturers offer a limited selection of the most popular ratings for direct replacement.

When direct replacements are not available, the following information should be helpful in adapting NEMA frame motors to the metric application.

Frame size. European frame sizes are handled in a different way from U. S. frame sizes. They are based on the shaft height (equivalent to our “D” dimension) *in millimeters*. For example, a 112 frame would have a 112 millimeters shaft height. Convert this to inches by dividing 112 by 25.4 to get an equivalent domestic shaft height. In this case, the shaft height of a 112 frame would be slightly over 4.4 inches and the closest NEMA frame motor would be a 180 series frame (182, 184, 182T or 184T) with a shaft height of 4.5 inches. This is true for IEC base mounted motors. In the case of this motor, it would be necessary to make adjustments on the machine that would allow for either using the 180 series frame domestic motor and aligning the shaft height difference or by selecting a 145T or 56 frame motor (3.5" shaft height) and shimming up to get the proper alignment. The bolt pattern on the bases of IEC motors are given as metric dimensions and it is impossible to get complete interchangeability with NEMA frame sizes. However, it is usually possible on foot mounted motors to adapt to domestic frame sizes by drilling new holes or making other accommodation to accept the different footprint of the NEMA frame motor. IEC frame sizes for rigid base motors and the associated metric dimensions are shown in Table 4. (Dimensions are in Millimeters — divide by 25.4 to get inch equivalents.)

Flange-mounted motors. Flange mounted motors become a real nemesis for conversion. There are two popular face mounting configurations used on the IEC motors. The most popular is the “B5” configuration, which is closest to NEMA “D” flange motors. The important thing to note is that with the B5 flange, *the clearance holes are in the flange* and the threaded holes are in the mating part, such as the pump, gear reducer or machine. The other popular IEC flange is the B14 flange. In this case, *the threaded holes are in the face of the motor* much the same as the NEMA “C” face motors.

IEC flange-mounted motors all have metric rather than inch shaft diameters and where threaded holes are involved, they are metric rather than “inch” threads. To replace metric flange mounted motors, an exact flange mounting equivalent would be necessary unless someone is resourceful enough to make adapter flanges that would convert NEMA “C” face motors to the metric dimensions required. Since this usually is not the case, metric flange mounted motors have to be replaced with metric motors. Table 5 shows typical metric dimensions for B5 and B14 metric motors. Note that dimensions are given in millimeters.

Baldor is now offering selections of metric, three-phase motors through 200kW. Also in stock are some permanent magnet DC motors that can be used as replacement units. On a custom basis when reasonable quantities are involved we can build many different metric equivalent motors.

Summary

This information should be useful in your day-to-day dealings in metric replacements. **PTE**

For more information:

Baldor Electric
5711 R.S. Boreham Jr Street
P.O. Box 2400
Fort Smith, AR 72901
Phone: (479) 646-4711
Fax: (479) 648-5792
www.baldor.com

Example of an ABB motor available in IEC frame sizes and specifications in metric dimensions.

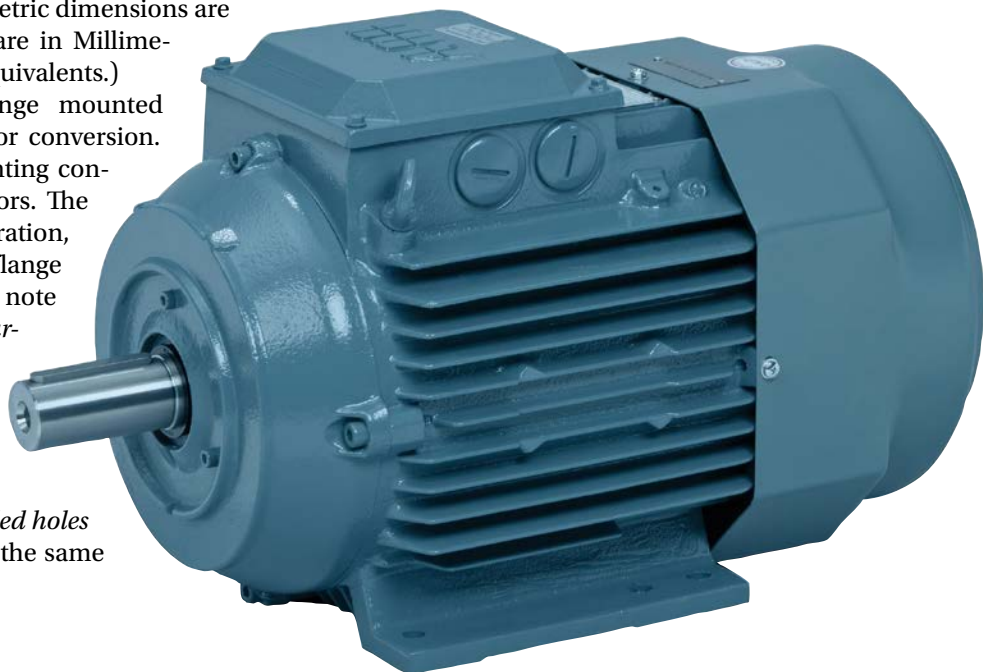

For Related Articles Search

motor basics

at www.powertransmission.com

Copper in Motor Repair Facilities

Charles Streu, Kenneth Jacobs and Kenny Jacobs

Three electric motor repair facilities share best practices for utilizing copper in motor repair, and recommending new motors to replace older, less-efficient motors

(NOTE: Electric motor service companies participating in this study include KJ Electric @ www.kjelectric.com; FLOLO Total Services Group @ www.flolo.com; and Industrial Motor Services, a division of EECO (Electrical Equipment Company) @ www.eecoonline.com. KJ Electric has offices in Syracuse, New York with satellites in Albany, Rochester and Buffalo. The FLOLO Total Services Group, located in Illinois, has four facilities: Franklin Park, Calumet City, Gurnee and South Elgin. EECO has locations in Richmond, Virginia; Raleigh, North Carolina; and Augusta, Georgia. Each provides reliable and comprehensive services for all motor-related needs. The actual locations of the motor repair facilities visited for this paper were: KJ Electric in Syracuse, New York; FLOLO Corporation in Franklin Park, Illinois; and EECO in Richmond, Virginia.)

The Motor Decision: Repair or Replace?

Electric motor repair service providers are well equipped to sell new Premium Efficient electric motors and to restore worn-out motors. Nationwide, motor repair shops account for about 50% of all new motors sold in the marketplace, due in part to the trust placed in the shops for superior repair, sage advice and long-standing relationships. While the service providers will educate and guide the customer in purchasing a new motor, motor repair may be the preferred option due to improved efficiency and for reasons relating to cost, size, functionality or critical need. Not all motors are candidates for replacement—repair is sometimes the best option. Therefore restoring an electric motor to or as close to its original efficiency is beneficial for both the consumer and the repair shop, and ultimately for the copper industry.

In this case study the practices of electric motor repair facilities are highlighted in the sale of Premium Efficient electric motors and in rebuilding and restoring older motors with copper in the stator windings and with improved bearings and insulation. Quality repair shops that adhere to the ANSI (American National Standards Institute)/EASA (Electro-Mechanical Authority) AR100-2015 Standard Recommended Practice for the Repair of Rotating Electrical Apparatus provide the best techniques in electric motor restoration by employing high-level methods of repair using a significant amount of copper. For publications on the criteria for selection of a motor repair shop and for references to industry standards such as ANSI/EASA AR100-2015, please visit www.copper.org and www.easa.com.

Electric motor repair service providers are well equipped to both sell new Premium Efficient electric motors and restore worn out or failed motors. Based on our interviews, the business distribution between supply of new motors vs. the repair of old motors varies between repair shops. At KJ Electric, for example, they estimate approximately 80% of their business entails new motors sold, compared to 20% made up of repaired motors.

Charles (Chuck) Streu, corporate staff, FLOLO Corp. stated that “New Premium Efficient motor sales are substantially more than that of our motor repair work. We estimate our business at 65% new motors sold and 35% repaired.”

At EECO’s Industrial Motor Services the distribution leans



Figure 1 Typical copper scrap after motor burnout at EECO.

more toward motor rewinding, with 32% new and 68% repair, primarily driven by their service to the heavy-duty, high-horsepower motors used in the forest products and chemical industries.

The criteria for a horsepower cut-off point for motor repair or replacement also varies across repair shops and is between 25 and 50 horsepower, but that cut-off point is primarily customer-driven. A better method of making that repair vs. replace decision involves the use of software tools to evaluate the motor for repair or replacement; this software is often provided by the repair shop or motor manufacturer.

This is where motor repair shops provide valuable services to their customers in the motor repair-or-replace decision. Even if the old motor is repairable, it might not be the best immediate or long-term financial decision for the customer. For every motor coming in for repair, a repair shop will perform a failure analysis and, in many cases, will provide an inspection report to the customer. This report presents them with the option of either a repair and its cost, or a new replacement motor, showing the price vs. the long-term energy savings associated with the Premium Efficient motor.

Kenneth Jacobs, CEO of KJ Electric, stated that “Aside from special purpose motors, every customer that brings a motor into KJ Electric for repair receives two quotes: one for repair and one for a new Premium Efficient motor. Most of our cus-



Figure 2 Rolls of new copper wire used in motor rewinds at FLOLO.

tomers have a 50% threshold when it comes to the repair vs. replace decision. If the cost of repair exceeds half the price of a new motor, they opt for the new motor. I encourage buying new rather than repair for motors below 50 horse power. This is an easy decision for the customer, because the repair cost is prohibitive for the lower horsepower motors and the customer ends up with a more efficient motor. If it is warranted, we will repair a motor over 50 horse power.”

Increasing Motor Efficiency with Copper

In most cases the new motor represents a significant increase in efficiency primarily because of the increased amount of copper in the stator windings of higher efficiency motors. Once the decision is made to repair a motor, its core is tested to validate that the magnetic properties of the core will support a copper rewind before it can proceed to the next step, which is the motor burnout in a temperature-calibrated oven in order to prevent any damage to the iron core. Following the burnout and the subsequent removal of the old insulation and copper, the core is reinsulated, rewound with new copper, and vacuum-impregnated with resin to protect it from chemical and moisture contamination.

A rushed repair is a bad repair; taking shortcuts in the repair process to get a quicker turnaround time for the customer is not sound practice.

“It is our responsibility to explain to the customer that it takes a given amount of time to burn their motor correctly so that we can return to them as efficient a motor as they brought to us for repair,” says Kenny Jacobs, the controls and drives product manager at KJ Electric. Burning a motor at too high a temperature in an attempt to shorten the time for a repair creates hotspots, reduces the efficiency of the motor and leads to early motor failure. At EECO, some motors with very large cores use a faster, safer and more economical high-pressure water coil stripping to remove the copper and insulation. This alternative leaves the motor core very clean, facilitating new copper coil installation.

A lot of copper flows in and out of these repair shops, according to Frankie Johnson, the motor winding jobs manager

at EECO.

“With three winding facilities, we use a lot of copper; 75,000 pounds or 34.5 tons of new copper and we reclaim about the same amount in scrap annually,” said Johnson.

EECO’s Industrial Motor Services specializes in the forest products industry, where heavy load demands put a lot of stress on the larger motors. Johnson continued, “The Richmond and Augusta locations rewind the larger motors. With 8-foot VPI (vacuum pressure impregnation) systems at each of those two facilities, we have repaired motors up to 3,000 horsepower. When the Raleigh winding facility has the larger jobs, we have them vacuum pressure impregnated at one of the other two locations.”

From the repair shop perspective, motor repair is a gateway to new motor sales. New motor sales equate to typically higher efficiency due to the increased use of copper, as well as other materials including bearings and insulation. These repair shops encourage their customers to buy new Premium Efficient motors, rather than repair a less-efficient Standard or Energy Efficient motor, where it makes economic sense. Sometimes the customer does not comprehend the savings from installing the new Premium Efficient motors. The savings in energy over a seven-year period alone are worth as much as five times the price of the new motor, according to Jacobs.

In addition to the mechanical improvements, manufacturers have made significant upgrades in the design of Premium Efficient motors. By adding more copper in the windings — higher-grade iron in the core and better insulation — they have increased the energy efficiency of these motors. One manufacturer, Siemens, has a copper rotor motor with improved efficiency above the Department of Energy’s (DOE) Premium Efficient label.

Says Jacobs: “There are two categories of customers — those seeking the lowest initial price, and those looking at the long-term cost of running a motor. The price of buying a new motor or repairing an old one is very inexpensive, compared to the operating cost of a motor over a 10-year cycle. Looking past the initial price is a challenge for some customers.”

In terms of data from the DOE, the purchase price of a mo-



Figure 3 Eight-foot vacuum pressure impregnation (VPI) system at EECO’s Industrial Motor Services in Richmond, VA.

tor represents 2% of the total cost of ownership — operating costs represent the other 98%. To help customers understand the long-term cost benefits of swapping out an old motor for a new Premium Efficient motor, KJ Electric will introduce the customer to the free motor survey programs — either through the sales representative or through direct mail.

Conclusion

When the decision is to buy new, the companies interviewed are well prepared to deliver from their inventory of Premium Efficient motors, and have arrangements with motor manufacturers to fully meet their customers’ requirements. In these new motors copper is a significant contributor to the increased efficiency. Combined with a solid preventative maintenance program, you not only get lower energy costs with the new motor but also less concern for future motor repair needs.

All three of the companies mentioned here provide services to their customers beyond assisting them with the decision between the purchase of a new motor or repair of an existing one. Because customers depend on motors and systems to be operational and available on-demand, they have developed what could be called a partnership with their service providers.

Service providers over time have become more innovative, responding to the evolving industry requirements in the area of maintenance and how it affects equipment reliability and safety. These companies provide preventative and predictive motor failure education and direct service — all of which can be queried at the respective company websites. Through these education programs and services the life of the motor system is extended not only past the warranty, but well into the useful life of the system. **PTE**

For more information

Copper Development Association Inc. — www.copper.org
 Electro-Mechanical Authority (EASA) — www.easa.com



Figure 4 Five-hundred-horsepower motor undergoing new copper coil insertion (photo courtesy EECO).

Charles (Chuck) Streu at FLOLO stated that, “New Premium Efficient® motors sales are substantially more than that of our motor repair work. We estimate our business at 65 percent new motors sold and 35 percent repaired.” At EECO’s Industrial Motor Services, the distribution leans more toward motor rewinding with 32 percent new and 68 percent repair, primarily driven



Kenneth Jacobs, CEO of KJ Electric, stated that “Aside from special purpose motors, every customer that brings a motor into KJ Electric for repair receives two quotes: one for repair and one for a new Premium Efficient® motor. Most of our customers have a 50 percent threshold when it comes to the repair vs. replace decision.



Kenny Jacobs, KJ Electric controls and drives product manager, says “It is our responsibility to explain to the customer that it takes a given amount of time to burn their motor correctly so that we can return to them as efficient a motor as they brought to us for repair.”



For Related Articles Search

motor repair 

at www.powertransmission.com



BROWSE OUR BLOGS!

PTE features three blogs to keep readers updated on the latest PT trends, technologies and industry solutions:

Bearings with Norm: Norm Parker is the bearing technical specialist for the driveline division at General Motors LLC and offers various insights and technical knowledge on the bearing industry.

Motor Matters with George Holling: The technical director at Rocky Mountain Technologies regularly contributes articles regarding motors, power quality, power factor, efficiency and more.

Editor's Choice: Our editorial staff provides relevant and timely articles on a variety of PT industrial topics.

Visit

www.powertransmission.com/blog/
to learn more.

Power Transmission Engineering

Engineering Showcase 2017

One of our goals at *Power Transmission Engineering* is to help you understand, identify and select the best technology for your mechanical power transmission or motion control applications. With every project, you have to decide which components to use, and which suppliers, based on functionality, quality and price. We aim to help you make those decisions *informed* by providing the latest information on current technology, especially when it comes to mechanical components.

With that in mind, we are pleased to present our fourth annual Engineering Showcase, a celebration of some of the leading products and companies in mechanical power transmission. In the pages that follow, you'll find examples of engineering excellence and technological know-how in the field of gears, drives, couplings, machine parts and other mechanical components.

This guide is meant as a complement to our annual Buyers Guide and our permanent online directory of suppliers at powertransmission.com. In this special section, we have the opportunity to go into more depth in describing the products and capabilities that make each of these suppliers unique.

So please browse through the section and read about the latest these suppliers have to offer. If you have an upcoming project that matches their manufacturing capabilities, we're confident that giving one of them the opportunity to bid will be well worth your efforts.



Randy Stott,
Associate Publisher & Managing Editor

Andantex USA Inc.

1705 Valley Road, Ocean Township, NJ 07712

Phone: 877.966.9151 (732.493.2812)

Fax: 732.493.2949

Email: info@andantex.com

www.andantex.com

Andantex USA Inc. has been providing quality, unique gearboxes for use on industrial machinery for over 35 years, delivering engineered solutions using high-precision motion control components.

New products provide complete solutions to Rack and Pinion Axis drives:

The complete solution is built from standard building blocks:

- Racks & Pinions
- Precision Speed Reducer
- Automatic Lubrication System
- Engineering Selection and Guidance to Optimize the Solution
- Installation Instructions and Assistance



The axis building blocks are:

Modular rack & pinion system providing standard rack sections and modules for building any length or precision linear axis.

Four families of planetary reducers optimized for stiffness & precision.

KRP+ Rack & Pinion dedicated planetary reducers are the SingleDRIVE flange mounted components in this family that provide minimum or ZERO-BACKLASH.

DRP+ DualDRIVE & TwinDRIVE includes integral output pinions and monoblock housing for universal mounting and dedicated solutions to ZERO-BACKLASH rack & pinion and rotary table drives.

KRPX are Side Mounted high performance planetary Servo-Reducer dedicated to rack & pinion or rotary applications. The accessible side mounting offers a cost effective, easy to implement installation.

SRP High-Tech Planetary reducers with ISO 9409-1 output flange are used for heavily loaded precise positioning applications.

HPG Servo-Worm Reducers for Positioning Applications

Servo-worm reducers offer cost-effective solution for material handling or pick and place requirements.

Mini In-Line Servo Reducers

This range of planetary reducers is designed for use with servo-motors in all kinds of industrial applications.

Automatic Relubrication System

The Flexxpump, a high-performance system to lubricate racks & pinions, open gearing, linear guideways, ballscrews and chain drives.

These building blocks are combined together to provide axis drives with the correct balance of precision, power and price for the following applications:

- Axes requiring precise positioning and repeatability
- ZERO-BACKLASH positioning and contouring drives
- Horizontal or vertical axes drives



These applications are found in the following industries:

- Machine Tool: Gantry Milling Machines, Horizontal Boring Machines, Large Horizontal & Vertical Lathes
- Carbon Fiber Placement Machines
- Material Handling Pick & Place Robots
- Ultrasonic Inspection Machines
- Cutting Machines: Laser, Waterjet, Plasma, Stone

ANDANTEX USA Inc.

2017 Engineering Showcase

Stock Drive Products/Sterling Instrument (SDP/SI)

250 Duffy Avenue, Hicksville, NY 11801

Phone: 516-328-3300

Toll Free: 800-819-8900

Fax: 516-326-8827

Email: sdp-sisupport@sdp-si.com

www.sdp-si.com

Stock Drive Products/Sterling Instrument a Designatronics company

Established in 1950, Stock Drive Products/Sterling Instrument (SDP/SI) is the company engineers and OEMs depend on for high-quality components, subassemblies, and engineering expertise. As a company founded and managed by engineers we understand and respond to the developing needs of our customers better than anyone. Over 100,000 components are available off-the-shelf for fast turnaround. When a standard part won't meet your requirements

we can provide alternative solutions through custom design and manufacturing.

Our engineering and manufacturing teams will partner with you

throughout the entire process. Located in New York, SDP/SI is remaining on Long Island, moving to a brand new state-of-the-art production and manufacturing facility in early 2017. By providing design, development, manufacturing, assembly, and testing in one location we can ensure the end product will meet your expectations. For prototype and small to large production runs you can rely on SDP/SI.

SDP/SI
STOCK DRIVE PRODUCTS/STERLING INSTRUMENT



High Volume Precision Gear Production

We manufacture precision gears, custom gearboxes, differentials, and planetary gearheads.

State-of-the-art gear production facility has increased capacity and offers new capabilities.

- High-precision gear production 24/7
- Faster turnaround – including gear cutting on CNC lathes for one piece flow (depending on quality (UP TO AGMA 11) and process requirements).

Stock Drive Products/Sterling Instrument, ISO 9001 + AS9100 Certified

SDP/SI designs, manufactures and produces custom and standard gears and other power transmission components. Our precision gears, gear assemblies, high-quality machined parts and molded components are used in a wide variety of product applications worldwide including aerospace, defense, military and commercial aircraft, robotics, and medical.

- Timing Belts and Pulleys
- Precision Gears
- Precision Gearboxes
- Precision Machined Components
- Molded Components
- Mechanical Assemblies
- Customized Components and Assemblies
- Contract Manufacturing

For a design consultation or technical assistance call our engineering department: (516) 328-3300.

Request a Free Inch and Metric Catalog Set, more than 2,784 pages of parts, specifications and technical information.



Napoleon Engineering Services (NES)

1601 Johnson Street, Olean, NY 14760

Phone: Toll-free (in the US and Canada) 877.870.3200

Outside of North America 716.372.6532

Fax: 716.372.1448

Email: sales@nesbearings.com

www.nesbearings.com

Napoleon Engineering Services (NES) specializes in custom bearing manufacturing. We are also the largest independent bearing inspection and bearing testing facility in North America. Our goal is to empower you with specialized bearing solutions related to custom bearing manufacturing and inspection and testing.

Why should NES be your bearing solution?

- Corrosion Resistant
- Temperature Extremes
- Load Extremes
- High Fatigue Life
- High Life Materials
- Cost Effective Solutions
- Bearing Size Range 20-350 mm
- Short Lead Times
- Small Production Runs
- High Precision Capabilities
- Advanced Design Technologies
- Over 100 years combined application experience and engineering knowledge
- Made in America

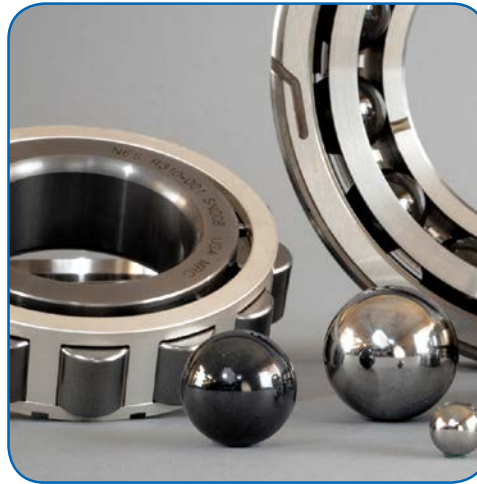

Custom Bearing Manufacturing

NES's design engineering and manufacturing capabilities provide customers with custom designed bearings without long lead times. Our knowledge and expertise allow us to analyze your application conditions and develop an advanced product that will meet or exceed your needs.

Types of Custom Bearings:

- Deep groove ball bearings
- Angular contact ball bearings
- Double-row self-aligning ball bearings
- Needle roller bearings
- Cylindrical roller bearings

Bearing Inspection & Testing

NES is the creator of inspection & testing programs supporting global bearing sourcing & bearing qualification. NES has been leading OEMs through the global bearing qualification process for 20 years providing technical information through bearing inspection, modeling and testing programs to evaluate bearing design, manufacturing capability, overall quality of workmanship, and the relationship these attributes have on bearing life. No other source has the experience, capacity or capability to service your bearing qualification needs like **NES – the World Leader.**

Industries & Applications

- Aerospace
- Defense
- Oil & Gas
- Power Generation
- Marine
- Industrial
- Transportation
- Gear Drives
- Medical
- Food Processing
- Agriculture
- Pumps/Turbines
- Generators
- Off-Highway
- Certifications
- ISO 9001:2008 Certified
- AS9100C Certified



2017 Engineering Showcase

R+W Coupling Technology

1120 Tower Lane, Bensenville, IL 60106

Phone: 630-521-9911

Fax: 630-521-0366

Email: info@rw-america.com

www.rw-america.com

R+W has always stayed in the forefront of breakthrough coupling technology and does its best to exceed customer's requirements and expectations. An ever-expanding product line helps them design the most optimal solution for nearly every application in any industry.

The most recent expansion of the ST product line shows the commitment that this company has to take on new markets and provide overload protection to even more customers than ever before. A new torque limiter department with its own facility has been created to reduce lead times further and focus on customization. This line of new industrial safety clutches has undergone vigorous testing not only at the company's R&D center, but also at partnered Universities in Germany including RWTH Aachen and University of Bayreuth. The added models feature new sizes as well as connection methods to provide more options than ever before.

Over the past 25 years, R+W has established itself as a precision couplings expert, and with these new safety coupling additions it plans to expand its expertise into the industrial sector as well. As always, customer's demands are top priority as engineers are ready to assist customers with customized solutions for complex coupling applications. Find out what the coupling technology leaders can do for you and get the best connection, worldwide.

RW-AMERICA.COM



R+W
A POPPE + POTTHOFF COMPANY



Schaeffler Group USA Inc.

308 Springhill Farm Rd., Fort Mill, SC 29715

Phone: 803-396-3643

Fax: 803-548-8599

Email: info.us@schaeffler.com

www.schaeffler.us

Schaeffler Engineering: Greater Than the Sum of Our Parts

When it comes to bearings, Schaeffler, together with our INA and FAG brands, has always been at the forefront of technological innovation. Industry firsts - such as the development of the needle roller & cage assembly, or the groundbreaking ball grinding machine that is regarded as the foundation of the entire rolling bearing industry - have earned Schaeffler a unique distinction among the world's great bearing companies. With nearly 85,000 employees working in approximately 170 locations in 50 countries, Schaeffler is one of the world's largest technology companies in family ownership.

SCHAEFFLER

In addition to rolling bearings for practically any application, linear bearings and guidance systems are also a vital part of Schaeffler's product portfolio. Unrivaled in scope and versatility, Schaeffler's linear product lineup ranges from shafts with linear ball bearings and monorail guidance systems

to sophisticated actuators with drives and control systems, plus special coatings and every conceivable accessory.

But that's only the start. Schaeffler's linear portfolio is based on a modular concept that goes far beyond mere components. We can design a complete system solution tailored to the customer's specific application - from large gantry robots to intricate circuit board inspection systems. In fact, many of our linear guidance systems started out as solutions to customers' needs! Case in point: Schaeffler's ingenious H-Bot XY positioning system.



PWG Differential Roller Screw

Sometimes, of course, a Schaeffler solution comes about because a customer's needs were not being met by the conventional standard. Such is the case with Schaeffler's innovative PWG differential roller screw. Within the pantheon of mechanical/linear drive systems, the screw category has been limited to lead screws, ball screws and roller screws.

Until now, that is.

In response to a customer's request for a solution that better addressed its ambitious price-performance target, Schaeffler recently developed the PWG differential roller screw: a new option that offers the high forces of a traditional roller screw, but at a price point closer to a ball screw.

So while innovative products make up the heart of Schaeffler's offerings to our customers, service represents the soul of what we do. Because when it comes to linear guidance systems, Schaeffler has all the pieces; you only have to supply the puzzle. Together, we'll create the perfect linear solution... yours.

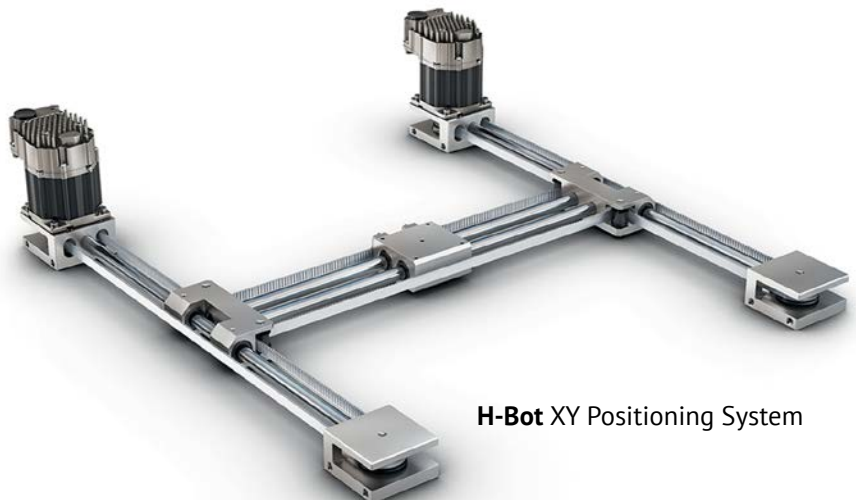

H-Bot XY Positioning System

2017 Engineering Showcase

Southern Gear & Machine

3685 NW 106 Street, Miami, Florida 33147

Phone: 800-248-5152

Phone: (local) 305-691-6300

Email: sales@southerngear.net

www.southerngear.net

60 Years on the Cutting Edge

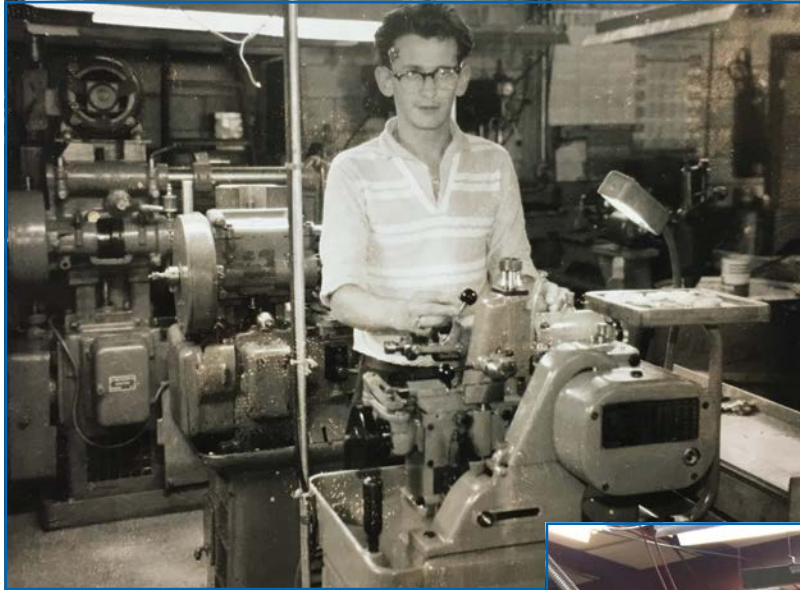

Southern Gear & Machine

is celebrating 60 years of leading the way in custom precision gear manufacturing. Our ongoing investment in technology and personnel keeps us on the cutting edge of gear manufacturing, providing the highest quality gears to the world's most demanding industries.



- Our machinists and engineers have an average of 26 years experience in gear manufacturing.
- Our employees have been with our company an average of 15 years.
- We have more than 50 gear cutting machines alone.
- We have invested close to one million dollars in new equipment each year for the past six years.

Cutting Edge Technology in Experienced Hands

QA1

QA1 is the #1 name in rod ends and spherical bearings. QA1's inch and metric rod ends and spherical bearings feature precise tolerances for quality and durability and are offered in a variety of styles and in alloy, carbon or stainless steel options. No matter what you're linking, you are sure to find exactly what you need and get it quickly from QA1.

Founded in 1993, QA1 built its foundation on quality and affordability being the number one priority. QA1's quality system is ISO 9001:2008 certified. By following



strict processes and adhering to exacting quality control procedures, QA1 ensures consistent products at competitive prices. With a wealth of engineering and manufacturing expertise

on staff, our products are designed, built and tested to ensure ultimate reliability and unbeatable performance. If you need custom linkage products, QA1's complete in-house design and engineering team and state-of-the-art manufacturing facility are dedicated to making it happen. QA1 is also a global provider of shock absorbers, suspension components, ball joints, clevises, rod eyes, jam nuts, spacers, custom linkage assemblies, carbon fiber driveshafts and more!

21730 Hanover Ave., Lakeville, MN 55044

Phone: 1-800-721-7761

Fax: 952-985-5679

Email: sales@qa1.net

www.QA1.net/industrial



Gear Technology

Gear Technology is where the world turns for information about gears and gear manufacturing. We reach a broad-based audience of gear industry professionals involved with every phase in the life of gears and geared products, from conception to design, from design to manufacturing, from manufacturing to inspection, from inspection to purchase and from purchase to end use.

Our magazine, website and e-mail newsletters are read in more than 60 countries around the world, at huge multinational corporation and small job shops, in high-tech engineering offices and on the factory floor.

If you have an interest in gear design, engineering or manufacturing, you should subscribe at: www.geartechnology.com/subscribe.htm

If you have an interest in reaching our audience of gear industry professionals, you should look into our advertising options at: www.geartechnology.com/adinfo.htm

1840 Jarvis Ave., Elk Grove Village, IL 60007 USA

Phone: (847) 437-6604

Fax: (847) 437-6618

E-mail: publisher@geartechnology.com

www.geartechnology.com



Sulzer

BREAKS GROUND ON TEXAS PUMP FACILITY

As part of the company's continued investment program, Sulzer is building a new, state-of-the-art pump services facility in Pasadena, Texas, to expand its increasing network in North America. Adjacent to the existing service center for electro-mechanical services, the new service center will be the new regional headquarter for pump services in the Americas and will provide increased pump maintenance capacity as well as additional technical support.



From left to right: Scott Fahey, Jim Mugford, Darayus Pardivala, Daniel Bischofberger and Gary Benard.

Construction began with a groundbreaking ceremony on January 13, 2017 and the facility is due to open in late fall of 2017. The aim of the project is to expand the network of service centers that provide cutting-edge services to customers in order to help minimize lead times for pump services, maintenance, repair and refurbishment.

Jim Mugford, president, electro-mechanical and pump services, explains: "Our current Houston facility has served us well, however, the new facility allows us to expand and pursue our strategy for regional growth. In addition to the increased workshop size, we are also investing in additional test, measurement and precision machine tools for completing modifications, repairs and upgrades to both Sulzer and third-party pumps. We will also be able to capitalize on synergies being located adjacent to our Sulzer electro-mechanical services facility which provides unique solutions by offering customers a one-stop service for both electric motors and pumps."

Sulzer offers repair and maintenance services for all types of rotating equipment including turbomachinery, pumps and electro-mechanical equipment. Its global network of over 150 manufacturing and service facilities deliver high quality, cost effective solutions that are customized to suit the business needs of each application.

The new service center will offer true 24/7/365 guaranteed support, with leading-edge maintenance and customized service solutions for pumping equipment. Sulzer pumps use state-of-the-art technology to deliver market-leading productivity and efficiency, with support from highly skilled engineers; a combination that ensures operational downtime is minimized. (www.sulzer.com)

Rexnord

OFFERS SHORTER STANDARD LEAD TIMES FOR FALK V-CLASS

Rexnord has established new, shorter standard lead times for products and accessories within the Falk V-Class Gear Drive portfolio, beginning at four weeks or less.

Standard lead times for V-Class unit sizes 107-167 begin at four weeks, with additional sizes and accessories at six and eight weeks, with plans to broaden the offering in 2017.



"We are proud to establish shorter lead times for the V-Class portfolio to help our users reduce unplanned downtime and shutdowns, and give peace of mind when orders become time-sensitive," says Ryan Schuller-Rach, gear product manager. "We have developed a process to make it as convenient as possible for our customers, and plan to improve the lead times and grow the portfolio of offerings within our standard lead times even more."

Examples of products that are offered with a four-week lead time include V-Class sizes 107-167, standard TA taper bushings, single and double-ended shafts, shaft fans, couplings, coupling guards, and package offerings such as the alignment-free option, Falk Reliability Package, and condition monitoring. Additional options are listed and offered under lead times of 6, 8, 10, and 12 weeks. (www.rexnord.com)

Ohio Transmission Corp.

ACQUIRES ASSETS OF ARGO INTERNATIONAL CORP IN NEW JERSEY

Ohio Transmission Corporation, an industrial equipment distributor and service provider headquartered in Columbus, Ohio, recently announced the acquisition of the assets of the Somerset, N.J. branch location of Argo International Corporation.

The New Jersey branch of Argo International Corp., is an



Industrial Technology Solutions

industrial distributor focused on the industrial markets for pumps, repairs and electrical products. The Somerset, N.J., branch will operate as a branch location of OTP Industrial Solutions, which provides expert solutions for industrial

pumps, electrical, motion control, fluid power, spray finishing and power transmission systems.

“Argo New Jersey is a strong Flowserve pump and repair distributor that expands our presence in the densely populated Northeast United States and is a perfect fit with our industrial pump, electrical, and service and repair businesses,” said Phil Derrow, president and CEO of Ohio Transmission Corporation. “Most importantly with all of our acquisitions, we welcome the addition of new associates to our team. OTC is a people-focused business with product and service experts who know how to help customers find the right solutions. Our eight new associates in New Jersey are excited to join our fast-growing company and we’re excited to work with them.” (www.otpnet.com)

Gleason

ACQUIRES KISSOFT AG

Gleason Corporation has announced that it has acquired KISSsoft AG, located in Bubikon, Switzerland. KISSsoft is a leader in the development of design software for gears and power transmission systems, serving customers globally across a wide spectrum of industries.

Dr. Ulrich Kissling, the founder and chief executive officer of KISSsoft, comments: “We are excited about our future partnership with Gleason. Given Gleason’s mission as a Total Gear Solutions Provider, its strength in bevel gear design and its position as a world leader in gear manufacturing and metrology solutions, the potential opportunities to provide our customers with new solutions is compelling. In addition, Gleason’s global reach and long-time customer relationships will open up new doors for our products.”

John J. Perrotti, president and chief executive officer of Gleason Corporation, adds: “KISSsoft joining Gleason will deliver significant synergies and provide our customers greater value by linking design and manufacturing expertise, having the potential to radically improve the efficiency of designs and the manufacturing solutions optimum for those designs. The KISSsoft team has developed a strong base of loyal customers that we look forward to serving together with KISSsoft.”

The KISSsoft management team and entire staff will remain intact with an ever-greater focus on serving its customers. They are looking forward to further collaboration with customers, partners and friends. (www.gleason.com) (www.kisssoft.ch)

Elmo Motion Control

EXPANDS OPERATIONS

Elmo commenced product manufacturing in Poland in Q2 2015. The new EU production facility is part of Elmo’s strategic plan to enhance its manufacturing capabilities.

During 2015/2016 Elmo substantially upgraded its production capabilities to fulfill the defined goals of higher capacity, zealous quality control and flexible, state-of-the-art manufacturing in order to efficiently meet customers’ needs.

The upgrade process involved two major activities: Updat-

Rocky Mountain Technologies

State of the Art Custom Design and Consulting Services

Where Innovation and Solutions Meet

- We Deliver Custom Motors and Drives
- We Design Your Custom Motors and Drives
- We Assist with In-House Design and Consulting
- Prototyping, Pre-Production, Product Performance
- Strategic Partners Volume Sourcing



(406) 552-4260

sales@rockymountaintechnologies.com

Rocky Mountain Technologies, P.O. Box 210, Basin, MT 59631

BEYTA GEAR SERVICE

**PUTTING
A LIFETIME**

OF

**GEAR
DESIGN**

EXPERIENCE

TO WORK FOR YOU

- Reverse engineering
- Gearbox upgrades
- Custom gearbox design
- Specification development
- Project management
- Vendor qualification
- Design reviews
- Bid evaluations
- Tooling design
- Customized gear training
- Equipment evaluation
- Custom machine design

Charles D. Schultz
chuck@beytagear.com
[630] 209-1652

www.beytagear.com

ing the production facility in Israel and opening the Elmo-owned production facility in Poland. The Polish facility has similar capabilities to Elmo's Israeli production facility, including a comprehensive manufacturing plant to produce Elmo's entire portfolio with full testing and burn-in infrastructure.

"Demand for Elmo's products has grown immensely and we have responded by tripling the production capacity of Elmo Israel and by opening our own production in the EU. This expansion illustrates our continued commitment to, and investment in, the design and manufacturing of the highest quality, most advanced, efficient and powerful servo drives and motion-controllers in the industry" said Haim Monhait, Elmo Motion Control CEO. "The location of the new production facility enables us to "get closer" to customers and also benefit from full compliance with the European Union Certificate of Origin (EU COO) requirements." Monhait added. (www.elmomc.com)

Lenze

NAMES PRESIDENT OF LENZE AMERICAS

Lenze SE, a global leader and manufacturer of electrical and mechanical drive, motion control and automation technologies, recently announced the appointment of **Ralph Rosa** as president of Lenze Americas.

"More than ever, Lenze's motion centric applications and solutions expertise can make a real difference for machine builders looking for higher productivity, better energy efficiency, lower system cost or global service support. We are thrilled to welcome Mr. Ralph Rosa as president of Lenze Americas. Under his leadership, Lenze Americas will build on our North American sales, production and engineering footprint for a dynamic future and the customers we serve," said Dr. Yorck Schmidt, member of the Lenze executive board and chairman, Lenze Americas.

Rosa is excited to join Lenze, an organization with one of the freshest product portfolios in the industry including newly launched product families and software such as: space-saving, flexible and low-cost i500 inverters; revolutionary and robust g500 geared motors; and time-saving *Fast Software Modules* for developing many automation applications. "Leveraging impressive worldwide capabilities, Lenze is uniquely positioned as a global Motion Centric Automation specialist and poised to dramatically expand in the Americas with its extensive new product offerings, industry expertise, and system capabilities," said Rosa.

Rosa brings a strong track record to Lenze with more than 25 years of experience at Eaton Corporation in the controls, automation, power electronics, and services businesses. At Eaton he achieved leadership positions running business units and large sales, marketing, and engineering organizations in the United States and Switzerland. Most recently,



Rosa served as president of Schaffner North America. While under Rosa's leadership, his businesses recognized significant market share growth and improved operational efficiencies.

Rosa attended Pennsylvania State University, where he earned a dual bachelor's degree in industrial engineering and general arts and sciences. He also holds an MBA from the University of Michigan. (www.lenze.com)

Force Control

ANNOUNCES NEW WESTERN REGIONAL MANAGER

Force Control Industries announces the addition of **Mike Fox** as new Western regional manager, supporting reps and distributors, OEM and industrial customers in the Western region of the United States and Canada. Fox has over 15 years of industrial equipment and power transmission components sales, and experience in many environments, including

food and beverage processing, chemical processing, HVAC, wastewater, and general manufacturing. He comes from MasterDrive, a sheave and bushing manufacturer. In this newly created position, Fox will work from his home office in Salt Lake City, covering northern California, Oregon, Washington, Idaho, Montana, Wyoming, Alberta, and British Columbia and Alaska. He can be reached at mfox@ForceControl.com or (801) 380-4038. (www.forcecontrol.com)



MPIF

APPOINTS NEW EXECUTIVE DIRECTOR/CEO

The Metal Powder Industries Federation (MPIF) and APMI International (APMI) have selected industry veteran **James P. Adams** to succeed C. James Trombino as executive director/CEO effective immediately.

Adams has worked in the powder metallurgy industry for more than 30 years following graduation from Hennepin Technical College in 1985. He began his career with MPIF in 2004 as director of technical services, working closely with the MPIF Technical Board, where he has been responsible for Federation publications, professional development programs, and conference technical programming. Under his direction, the Metal Injection Molding and Additive Manufacturing with Powder Metallurgy conferences were developed. He has also served as administrative director for APMI International, and the Center for Powder Metallurgy Technology (CPMT).



Adams took on additional roles as administrative director for the Powder Metallurgy Parts Association (PMPA), Metal Powder Producers Association (MPPA), Powder Metallurgy Equipment Association (PMEA), and Isostatic Pressing Association (IPA), all affiliated associations within the MPIF umbrella. Additionally, he has also been MPIF's representative for the Lightweight Innovations for Tomorrow, a National Network for Manufacturing Innovation Institute, to aid in the promotion of lightweight technology development.

"MPIF has been a global leader and voice for the North American powder metallurgy industry for nearly 75 years, and to be its fourth executive director is an honor and privilege," Adams said. "Jim Trombino has left MPIF positioned for the future, and I look forward to serving the current industry while advancing emerging technologies such as metal additive manufacturing." (www.mpif.org)

Timken

APPOINTS MANAGING DIRECTOR OF CANADIAN OPERATION

The Timken Company has announced the appointment of **Sean Hazelton** to managing director for Canada for the company's process industries and mobile businesses. In this role, Hazelton will lead Timken's business operations in Canada. He reports to Brian J. Ruel, vice president for the Americas. Hazelton joins Timken from Canadian Bearing where he was the strategic business manager. Previously, he worked at Emerson Canada for 17 years in various leadership positions including sales, marketing, business development and operations. He earned a bachelor's degree from York University and a master's degree in business administration from Ivey Business School, University of Western Ontario. (www.timken.com)



Brother Gearmotors

HIRES NEW DIRECTOR OF SALES

Brother Gearmotors, a division of Brother International Corporation that offers a wide range of ultra-reliable, sub-fractional AC gearmotors and reducers for the food & beverage, packaging and material handling industries, has hired **Bernie Hurda** as its new director of sales. As the newest team member of the Bridgewater, New Jersey-based business unit, Hurda will steer overall sales strategy, including managing a sales team, overseeing a broad sales structure, and developing additional business channels.



Brother Gearmotors is one of the world's largest fine-pitch gear manufacturers and meets industry demand for smaller, lighter, reliable and energy-efficient power transmission components. The company offers a wide range of high-quality, sub-fractional AC gearmotors and reducers in demanding industries such as food and beverage, packaging and material handling.

Hurda has been involved in the power transmission industry for more than 16 years, beginning his career as a sales engineer and, later, serving as field sales manager and eventually national sales and marketing manager.

"Bernie's exemplary sales record and management skills made him a natural choice as Brother Gearmotors' newest director of sales," said Matthew Roberson, senior director of Brother Gearmotors. "In addition, his knowledge of the Brother product line eliminates the product learning curve typical of new hires — an important point given the complex industries in which we thrive."

Hurda attended the University of Wisconsin, earning an undergraduate degree in marketing education and an MBA in management. A father of three, he resides with his wife in Sussex, Wisconsin. (www.brother-usa.com/gearmotors)

Custom Machine & Tool

LAUNCHES NEW WEBSITE

Custom Machine & Tool Co., Inc., (CMT) a U.S. manufacturer in the power transmission and motion control products industry, recently announced they have launched a new interactive website with more viewing options and content.

"We are very pleased to see the results of our customers' feedback implemented into a new dynamic interactive website. Visitors to the new site now have more viewing options, enjoy easy navigation, and fast access to the detailed information in our product catalogs," says owner and president of Custom Machine & Tool Co., Inc., Robert Bennett.

Custom Machine & Tool Co., Inc. manufactures precision timing pulleys; the patented Concentric Maxi Torque keyless hub to shaft connection systems; drive systems; and components for the motion control and power transmission markets. CMT has been the preferred choice for pulley stock by OEM's and distributors for over 45 years. The company guarantees shipment of up to five pieces of pulley stock within 72 hours. See 'Timing Pulley Stock Shipping Program' for more details. (www.cmtco.com)

Setting Sights on Hannover Messe 2017

Digital and industrial sectors collide in Germany for popular trade fair

Matthew Jaster, Senior Editor

The last time I attended Hannover Messe in Germany (2013) the talk about the factory of the future, digitalization and Industry 4.0 was really picking up steam. As I prepare for the 2017 show, we've reached a fever pitch regarding these manufacturing buzzwords. So where exactly is the conversation going today?

It appears companies interested in utilizing some of the many high-tech solutions available are not short of options. Collaborative robots, predictive maintenance, smart materials, machine learning, digital twins and integrated energy all fall under the rather daunting Industry 4.0 umbrella. The question for manufacturers becomes what will *really* work for their organization and, more importantly, why should they bother?

"The task is to ensure that decision makers from industry and the energy sector understand the direct, long-term benefits that digitalization can offer their organizations, business models and employees," said Jochen Kockler, managing board member for Deutsche Messe. "This is a landscape in which mechanical engineering and I.T. are converging. This is digitalization, and Hannover Messe will show visitors how to recognize its benefits and make them their own."

This is going to be the focus at Hannover Messe. Hannover officials believe that in the not-too-distant future, manufac-

turing systems will incorporate machine-learning technologies that analyze data centrally and feed the results back to the production machines in question, thereby enabling them to learn and self-optimize. As such, machine learning is fundamental to predictive maintenance at this year's show.

Organizers say that despite the ongoing and rapid spread of digitalization, people will always be absolutely critical to success in industry. Industry 4.0 technologies will help make factory workers' duties more interesting and varied. Instead of focusing on repetitive manual tasks, factory employees will increasingly be called upon to solve problems, make decisions, innovate and drive value-adding initiatives. But this will not happen in a vacuum. Manufacturers need to invest in upskilling and education measures to prepare their workforces. "In tomorrow's agile, flexible factories, employees will be experts in the use of virtual reality, augmented reality, smart glasses and tablets. All of these exiting new digital factory tools will feature prominently at Hannover Messe 2017," Kockler explained.

Some other interesting news coming out of Hannover is the return of the Young Tech Enterprises hub (Hall 3). Young Tech Enterprises is where Hannover Messe founders and young companies meet startup networks, accelerators and economic development organizations as well as large companies and investors.

All photos courtesy of Hannover Messe.



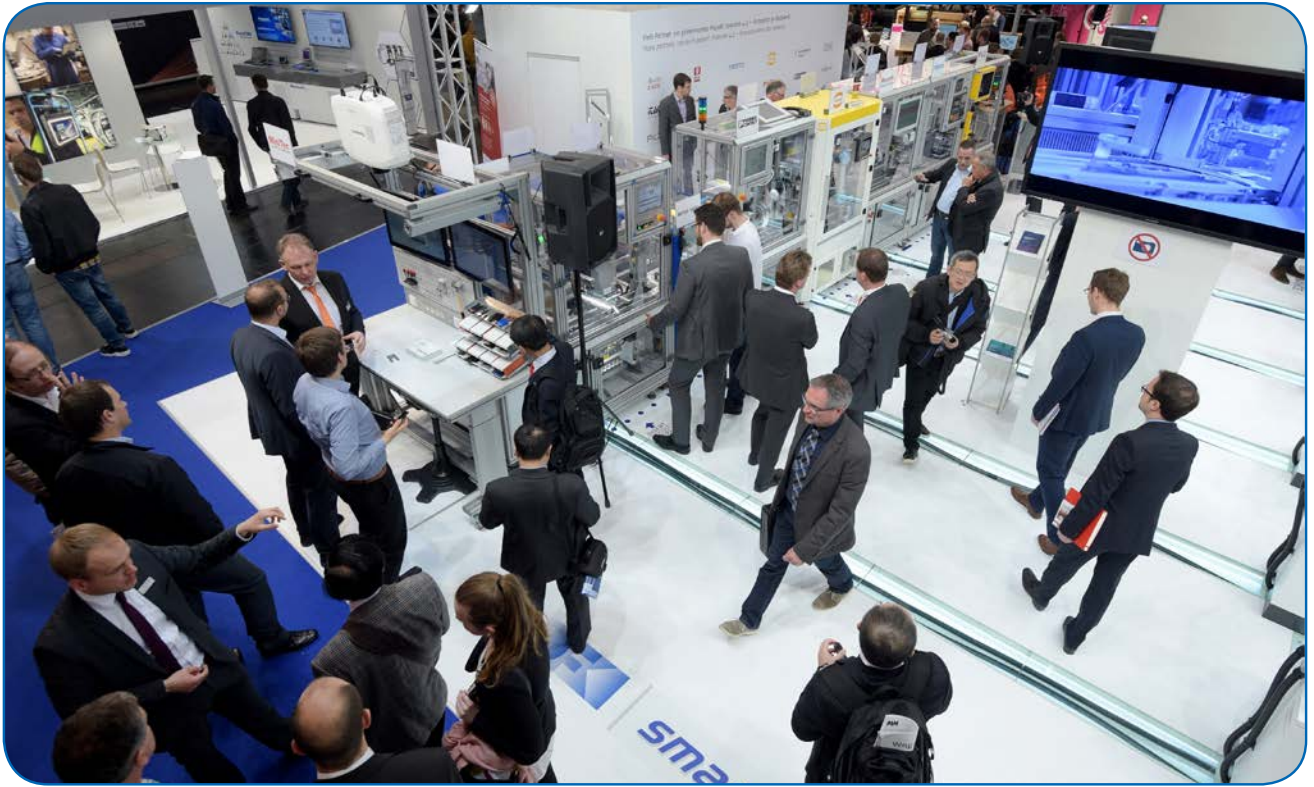

The program features an exhibition area as well as a forum, pitching and matchmaking events, and workshops. Participants also profit from the synergies of research and technology in Hall 2 plus access to the thousands of exhibitors and investors at the trade fair. Young Tech Enterprises showcased 116 companies from 12 countries in 2016.

The competition “Startup Pitches @ Young Tech Enterprises” is all about brevity: each challenger has only a few minutes to convince the audience of his product’s advantages. Altogether 32 exhibitors compete for prize money of 5,000 euros as well as new supporters and investors. Berlin-based FDX Fluid Dynamix GmbH won in 2016 with its OsciJet nozzles, which mix gases and liquids without moving parts.

In addition to Young Tech Enterprises, Hannover offers startups further tailored participation options. Germany’s Federal Ministry for Economic Affairs and Energy (BMWi) sponsors the program “Young Innovative Companies,” which features group exhibits for startups in three sectors: Digital Factory, Energy and Industrial Automation. A participation package includes a turnkey exhibit as well as central administration and a shared meeting lounge. BMWi assumes up to 60 percent of participation costs. Approximately 40 companies took advantage of the offer in 2016.

Poland is this year’s partner country. Apart from domestic reindustrialization, the country’s main economic focus is on opening up foreign markets and supporting innovative Polish companies. Around 150 of these companies will feature at this year’s show. Together, they will mount a Partner Country showcase that will center on the themes of energy and I.T.

“Being next-door neighbors, Poland and Germany are already strong partners,” remarked Köckler. “Poland will demonstrate its innovative spirit and its dynamic uptake of digitalization-factors that make it a key player on the global stage.”

150+ Polish companies will exhibit on about 4,000 square meters (43,000 sq. ft.) of display space spread across all of Hannover’s trade shows. This compares with about 80 companies in 2016. The lineup will include a sizable contingent from Poland’s energy technology and industrial subcontracting sectors.

Overall organization and coordination of this year’s Partner Country showcase rests with the Polish Agency for Enterprise Development (PARP). The National Center for Research and Development (NCBR) will be running a pavilion at the Research & Technology show in Hall 2. Meanwhile, the Polish government’s central pavilion will be in Hall 3. This is the heart of the showcase and will feature group presentations by ten of the country’s provinces. Poland’s Ministry of Science and Higher Education will also be using pavilion to profile a number of stand-out innovations from the country’s industrial sector. There will also be Polish group pavilions dedicated to industrial subcontracting (Hall 4), the foundry industry (Hall 5/6), electrical engineering (Hall 13), heating and cooling supply technology (Hall 27) and electric transportation (open-air site). (www.hannovermesse.de) **PTE**

Automate 2017

Highlights Solution Providers and Integrators

Matthew Jaster, Senior Editor

Automate 2017 (April 3–6) will showcase the full spectrum of automation technologies and solutions, from traditional industrial applications to cutting edge new technologies. Live show demonstrations will inform the industry on the successful integration of automation, robotics and machine vision. The rest of the show features the latest automation, robotic, vision and motion control technologies and systems on display from leading global suppliers. A comprehensive educational conference accompanies the Automate show. Featuring a broad array of classes from beginner to advanced skill levels, the conference offers something for all attendees — they can take one class or four full days of training. Classes are taught by experienced industry professionals who understand the industry challenges attendees face. ProMat 2017 is co-located with Automate and provides attendees access to the latest material handling and logistics equipment and technologies.

Conference Highlights

Here's a quick rundown of some of the educational opportunities available at the Automate Conference. The conference includes everything from a basic understanding of automation to more advanced courses including the 48th Annual International Symposium on Robotics.

Monday April 3

- The Fundamentals of Machine Vision (8:00 am–12:00 pm)
- The Trend toward Flexible Manufacturing (9:00 am–11:00 am)
- Advances in 3D Vision (3:00 pm–5:00 pm)

Tuesday April 4

- Basic Machine Design and the Physics of Motion (9:00 am–10:00 am)
- Mechanical Motion Control Components and Subsystems (10:00 am–11:00 am)
- Positioner Selection and Motor Sizing (3:00 pm–4:00 pm)

Wednesday April 5

- Digital Servo Amplifier Basics (9:00 am–10:00 am)
- Advances in Motion Control Technologies (9:00 am–11:00 am)
- Overcoming Food Processing and Packaging Challenges (3:00 pm–5:00 pm)

Booth Previews

Here's a quick rundown of some of the products and technologies attendees should check out during the show.

ATI Industrial Automation (Booth #N-1621)

ATI will feature several large robotic demonstrations in their exhibit (booth #N-1621) in addition to the following new products:

The new QC-46 Tool Changer is extremely lightweight—only 6.5 lbs (2.98 kg)—and has a very low stack height of 2.61 inches (66.3 mm). It utilizes the same proven Locking Mechanism as the QC-40 Tool Changer, and handles payloads up to 110 lbs (50 kg). The QC-46 can accommodate up to seven separate utility modules to handle a large variety of signals, fluid, air, and other requirements. The QC-46 also features optional internal Lock/Unlock sensing and direct mount to robots with a 100 mm ISO pattern.



ATI's Modular Tool Stands maximize flexibility with ATI's wide range of Robotic Tool Changer models. The modular system concept allows you to "build your own" tool storage rack based on the number of tools, positioning, orientation, and mounting arrangements required. ATI will have a large variety of Tool Stand options on display.

The Axia80 Force/Torque Sensor is a lower-cost sensing solution that maintains the quality and accuracy found in all of ATI's Force/Torque Sensor products. All the electronics are built into the transducer body which keeps the cost down and footprint smaller, while excelling in accuracy, resolution, and robustness. The Axia80 will be available in Ethernet and EtherCAT versions and will feature a high signal-to-noise ratio and high overload protection, between five and 20 times over the sensing range. (www.ati-ia.com)

CENIT (Booth #2025)

The trend of highly individualized products leads to many unique variables, low production batches, and the need for flexible automation systems. To support this steady evolution, a next generation of Digital Factory tools is required. At Automate 2017, the software specialist CENIT is presenting a powerful and efficient solution: the high-performance Digital Factory software — *FASTSUITE Edition 2*.

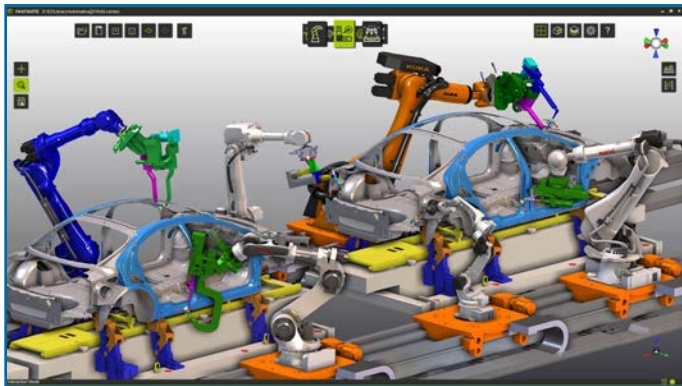

Digital Factory methods including virtual process planning, offline-programming, simulation, and optimization will become mandatory to enable new technologies and to increase the production efficiency. *FASTSUITE Edition 2* is a stand-alone simulation platform that supports production with an offering of best-in-class software technology. The software addresses the entire process — from engineering to the virtual start of production. With this program, users can create, program and operate robots, machines, and production systems for specific technologies based on accurate, high performance simulations.

All of the technologies and functions interact seamlessly and complement each other in a single, innovative user interface with a standardized data model. This ensures an efficient workflow with full process control, while preventing data redundancy or the loss of information. The scope of functions includes process-driven technology and control packages to provide offline programming even for sophisticated applications and technologies. With these basic features, users can get started quickly, and conveniently draw on proven solutions. CAD data is imported using standard interfaces like STEP or JT, or via direct interfaces to NX, CATIA, SolidWorks, etc. (www.cenit.com)

R+W Coupling Technology (Booth #968)

R+W will be demonstrating the benefits of using mechanical overload protection in a high-performance servo drive application. The SK and SL series torque limiters can disengage the driveline within 2-4 milliseconds of a torque spike resulting from unintended blockage and overload, potentially preventing critical damage to expensive equipment. The latter, SL series, features a special compact and low inertia design for cutting edge automation requirements. R+W safety couplings come in both direct (shaft-to-shaft) and indirect (shaft-to-pulley) mounting options to be used in almost any



application where mechanical overloads may occur. Much of the SL series is available in stock in Illinois to reduce delivery from several weeks to just a few days in case of an emergency requirement. Stop by the R+W booth to find out more about modern torque limiter technology and how it might be useful for your applications. (www.rw-america.com)

Promat 2017

The latest manufacturing, distribution and supply chain equipment and systems will be on display at Promat (co-located with Automate 2017). More than 850 solution providers will discuss their latest supply chain innovations and help attendees build business partnerships with suppliers from around the world. More than 100 show floor seminars will be available including town hall style sessions on autonomous vehicles and sustainable facility solutions. Key exhibitors include Epicor, Regal Power Transmission Solutions, Aerocom, Alba Manufacturing and more.

(www.automateshow.com) **PTE**



April 19–21—2017 AGMA Fundamentals of Gear Design and Analysis

Indianapolis, Indiana. This course provides a fundamental understanding of gear geometry, types of arrangements, design principles, the basic gear system design process, and gear measurement and inspection techniques. It is designed for powertrain engineers, engineering directors and managers, component suppliers, vehicle platform powertrain development specialists, and those involved in the design and application of geared systems and assemblies. The course will be facilitated by William “Mark” McVea, Ph.D., PE. Dr. McVea is president and principal engineer of KBE+, Inc. where he and his team design and develop complete powertrains for automotive and off-highway vehicles. For more information, visit www.agma.org.

April 24–28—Hannover Messe 2017

Hannover, Germany. “Integrated Industry—Creating Value,” is the official theme for Hannover Messe 2017. With Industry 4.0, integrated energy, digital twins, predictive maintenance, digital energy, and networked and collaborative robots (cobots), companies of all sizes today have a multitude of high-tech solutions to choose from. But often they find it difficult to predict what value these sorts of solutions might add. Many understandably balk at committing to major capital investments without concrete prospects of measurable benefits. Hannover Messe 2017 will demonstrate how even companies with limited resources can pinpoint and harness the power of digitalization. This year’s trade fair lineup includes Industrial Automation, Motion, Drive & Automation, Digital Factory, Energy, ComVac, Industrial Supply and Research and Technology. Poland is the official Partner Country for the 2017 show. For more information, visit www.hannovermesse.com.

April 25–27—Reliable Plant 2017

Columbus, Ohio. This three-day event offers attendees learning sessions and case studies on the latest industrial lubrication and oil analysis technologies. The comprehensive conference schedule covers every facet of the machinery lubrication industry and includes workshops on topics such as employee performance, lubrication fundamentals, condition-based maintenance and maintenance planning. The 150,000 square foot exhibit hall, receptions and educational sessions facilitate networking opportunities as well as the implementation of new ideas attendees can bring back to their manufacturing facilities. Reliable Plant is focused on both entry level and management positions within the lubrication industry including engineers, plant managers, maintenance professionals, safety personnel, planners, quality managers and more. For more information, visit conference.reliableplant.com.

April 30–May 3—CIM 2017 Convention

Montreal, Quebec. Founded in 1898, the Canadian Institute of Mining, Metallurgy and Petroleum (CIM) is the leading technical society of professionals in the Canadian Minerals, Metals, Materials and Energy Industries. The CIM Expo features nearly 450 companies showcasing the latest in mining equipment, tools, technology, services and products. The event includes plenary sessions intended to bring focus and start dialogue around the conference theme of “New State of MINE.” Leaders from all aspects of mining and some from unexpected tangential sectors

are brought together in these thought-provoking discussions. For more information, visit convention.cim.org.

May 1–4—Offshore Technology Conference 2017

The Offshore Technology Conference (OTC) is where energy professionals meet to exchange ideas and opinions to advance scientific and technical knowledge for offshore resources and environmental matters. OTC is the largest event in the world for the oil and gas industry featuring more than 2,300 exhibitors, and attendees representing 100 countries. Founded in 1969, OTC’s flagship conference is held annually in Houston. The event provides excellent opportunities for global sharing of technology, expertise, products, and best practices. OTC brings together industry leaders, investors, buyers, and entrepreneurs to develop markets and business partnerships. Technical highlights include updates on world-class projects, offshore renewable energy, the digital revolution, safety and risk management and more. For more information, visit <http://2017.otcnet.org/Content/Welcome>.

May 2–4—AGMA 2017 Gearbox System Design

Clearwater Beach, Florida. Learn the supporting elements of a gearbox that allows gears and bearings to do their jobs most efficiently. Gain a deeper understanding about seals, lubrication, lubricants, housings, breathers, and other details that are involved in the designing of gearbox systems. Gear design engineers; management involved with the design and manufacture of gearing type components; metallurgists and materials engineers; laboratory technicians; quality assurance technicians; furnace design engineers; and equipment suppliers should attend. Instructors include Raymond Drago and Steve Cymbala. For more information, visit www.agma.org.

May 8–11—Rapid + TCT 2017

Pittsburgh, Pennsylvania. RAPID + TCT is an additive manufacturing event that showcases product innovations and offers collaborative learning opportunities to ultimately accelerate the adoption and advancement of the technology. The two industry leaders in 3D technology events, SME and Rapid News Publications Ltd., are combining their nearly 30 years of insights and experience to produce the annual RAPID + TCT event starting in 2017. At RAPID + TCT, attendees will have the opportunity to engage with the most influential community in 3D technology. Explore the future of the industry through interactive experiences, 200+ hands-on exhibits, keynotes, and conference presentations from industry leaders. For more information, visit www.rapid3devent.com.

May 16–18—EASTEC 2017

West Springfield, Massachusetts. With more than 500 exhibitors, complimentary conference sessions, industry keynotes and much more, EASTEC is an event dedicated to keeping northeast manufacturers competitive. It’s where manufacturing ideas, processes and products that make an impact in the northeast region, are highlighted through exhibits, education and networking events. The Smart Manufacturing Hub examines IIoT, 3-D printing, and the latest automation technologies. For more information, visit www.easteconline.com.

Hungry for More?



Everything you need if you buy gears, bearings, motors, couplings and clutches.

Power Transmission Engineering

- Product and Industry News Updated Daily
- Directory of Mechanical Power Transmission Suppliers
- Exclusive online content in our e-mail newsletters
- Back Issues and Article Archive
- Calendar of Upcoming Events for power transmission professionals

FREE SUBSCRIPTION!

www.powertransmission.com

CALL FOR PAPERS!

Are you sitting on an idea for a technical paper but wondering where to present it? Do you have one already written, sitting on your desk, gathering machine dust?

How about *Power Transmission Engineering*? We are always looking for gearing- and power transmission component-relevant technical papers for publication in the magazine and in its digital version. Having your work appear in *Power Transmission Engineering* guarantees you an audience of the most experienced and discriminating industry players. You say your work has not been peer-reviewed? Not a problem, as we are lucky—and thankful—to have on-hand some of the most experienced and brilliant minds in the industry—our technical editors. So if your work “passes muster” and is published, you’ll know you were reviewed by the best—and most demanding.

Chances are you’ll be creating the paper under the auspices of the company for whom you work or own, or for one of the various industry-relevant associations. That means they as well will bask in the reflected glory that accrues with publication in *Power Transmission Engineering*.

For publication guidelines and more information, please contact Jack McGuinn at jmcguinn@powertransmission.com.

AGMA

Page 19
www.gearexpo.com

Andantex USA Inc.

Page 53
www.andantex.com

Automate 2017

Page 23
www.automateshow.com

B&R Machine and Gear

Page 32
www.brgear.com

Beyta Gear Service

Page 61
www.beytagear.com

Brother International

Page 7
BrotherGearmotors.com

Circle Gear

Page 17
www.circlegear.com

Designatronics

Pages 3, 54
www.sdp-si.com

Diequa Corp.

Pages 9, 33
www.diequa.com

Gear Expo

Page 19
www.gearexpo.com

Martin Sprocket

Page 15
www.martinsprocket.com

McInnes Rolled Rings

Page 12
www.mcinnesrolledrings.com

Napoleon Engineering Services

Page 55
www.nesbearings.com

Neugart USA

Page 13
www.neugartusa.com

Nordex Inc.

Pages 10, 32
www.nordex.com

QA1 Precision Products

Page 59
www.qa1.net

R+W America

Pages 11, 56
www.rw-america.com

Rocky Mountain Technologies

Page 61
www.rockymountaintechnologies.com

Schaeffler Group

Back Outside Cover, Page 57
www.schaeffler.us

SEW-Eurodrive

Inside Back Cover
www.seweurodrive.com

SKF

Inside Front Cover
skf.com

SDP/SI

Pages 3, 54
www.sdp-si.com

Southern Gear & Machine

Page 58
www.southerngear.net

Suhner Manufacturing

Page 2
www.suhner.com

Turner Uni-Drive

Page 32
www.turnerunidrive.com

Zero-Max

Page 5
www.zero-max.com

Power Transmission Engineering



Power Transmission Engineering is Your KEY to understanding Gears, Gear Drives, Bearings, Motors, Clutches, Couplings, Brakes, and other Power Transmission Components.

Unlock your FREE subscription by filling out this form.

FREE SUBSCRIPTION

1 **YES** I want to receive/continue to receive **Power Transmission Engineering** FREE!
 No thank you.

Name: _____ JobTitle/Position: _____
(print)

Signature _____ Date: _____
(required)

2 → E-mail _____
(So we can notify you when the online edition is available)

 **SAVE a TREE!**
 I ONLY want the digital edition (e-mail required)

3 → Please update your contact information or attach you business card here. (No Staples)

Company Name: _____
Address: _____

City: _____
State/Province: _____ ZIP+4/Postal Code: _____
Country: _____
Telephone: _____ Fax: _____
E-mail: _____
Website: _____

5 → My company's principal product or service is: _____

6 → What is your primary job function responsibility? (Check one)

<input type="checkbox"/> Corporate Management (1)	<input type="checkbox"/> Quality Control (7)
<input type="checkbox"/> Plant Engineering (2)	<input type="checkbox"/> Factory Automation (8)
<input type="checkbox"/> Design Engineering (3)	<input type="checkbox"/> Maintenance (9)
<input type="checkbox"/> Marketing & Sales (4)	<input type="checkbox"/> Other (10)
<input type="checkbox"/> Manufacturing Engineering (5)	
<input type="checkbox"/> Purchasing (6)	

Is there a colleague within your company that might benefit from having their own copy of **Power Transmission Engineering** magazine?

Name: _____
Title: _____

4 → How is THIS LOCATION involved with power transmission products? (Check all that apply)

WE MAKE power transmission products (10)
 WE BUY power transmission products (12)
 WE SELL power transmission products (Distributors, sales reps. etc.) (14)
 WE DESIGN products with power transmission components in them. (16)
 Other (please describe) (15) _____

DIGITAL SUBSCRIPTIONS

YES, I want to be notified each issue when *Power Transmission Engineering* is available online

YES, I would like to receive *Power Transmission Engineering's* monthly e-mail newsletter

YES, I would like to receive *Power Transmission Engineering's* twice monthly e-mail Product Alerts

YES, I would like to receive 3rd-party e-mails from *Power Transmission Engineering's* advertisers and partners

YES, I would like to receive subscription renewal notices by e-mail

No, I do not wish to be contacted by e-mail.

FAX TO 1-847-437-6618 or
VISIT US ONLINE AT
www.powertransmission.com/subscribe.htm

Your Robotic Chariot Awaits

Furrion is developing a mech in the hopes of launching racing into realms so far only explored by science fiction.

Alex Cannella, News Editor

Call it a mech, call it an exosuit, even call it pure science fiction if you want; Furrion's Prosthesis is freaking cool.

At 14-feet tall and 7,000 pounds, the Prosthesis is a titan of chromoly tubes and ambition.

And the craziest part? This giant mech is a man-powered racing machine.

"Prosthesis is a sports machine," Jonathan Tippet, president and CTO of Furrion Robotics, said. "It is 100 percent human controlled and will require an athlete to operate but will rely more on skill than on strength. With no autonomy, gyros or self awareness, it relies completely on the skill of the pilot to run and jump."

Well, to say this monster is entirely man-powered isn't entirely accurate. The Prosthesis is also packing a 200-hp lithium ion battery to power its systems. But there's no joystick to direct it with. Instead, it's designed to follow the pilot's movements through an "exo-skeletal interface" that they wear and translates those movements into the machine's. When you take a step, your big, metal exosuit does, too.

"Prosthesis was designed from inception with the pilot in mind first and foremost," Tippet said. "While Prosthesis gets its power from batteries, it gets its control from the human pilot. This has always been central to its purpose: to create a new human experience based on skill and physical mastery. Humans are still the most sophisticated and adaptable motion control systems."

The Prosthesis is capable of some astonishing feats of motion for a fledgeling mech of its size. It's designed to sprint at speeds of up to 30 km/h, is capable of turning at speed and, perhaps most impressive of all, can actually jump.

Furrion's Robotics division has been working on the Prosthesis for seven years now. The project is a departure for the



company, which has other divisions making everything from kitchen appliances to solar powered batteries, and is the freshman project for the team.

"Prosthesis is the culmination of many influences in over the course of my life, ranging from mountain biking, to snowboarding and all they way back to a childhood love of dinosaurs," Tippet said. "I was inspired to embark on such an ambitious project by my trips to Burning Man, where giant, mechanized, interactive art projects are in abundance. I wanted to build a powerful, technically sophisticated machine that was focused on the experience of the pilot and celebrated the pursuit of skill and physical mastery."

However, Furrion's efforts have only just begun. The company's ambition goes well beyond the Prosthesis itself, which is merely the first of its kind. They're hoping to spawn an entirely new sport featuring giant mechs racing through the desert.

The Prosthesis is still in the tail end of development, so if Furrion can live up to that image remains to be seen. But whether Furrion can pull it off or not, if the possibility of watching racers duke it out in the desert in a bunch of giant mechs isn't enough to get the science fiction fan in you excited, I don't know what will.

PTE

For more information:

Furrion Robotics

Phone: (888) 354-5792

www.furrion.com/services/robotics.html



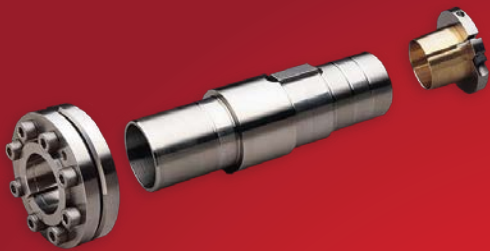

Assembly



Disassembly

Can't get it off?

Having a hard time removing a corroded gear unit from your machine shaft? Well, stop fretting. Wise up and get **TorqLOC®** from SEW-EURODRIVE.

With its stainless steel construction, **keyless** hollow shaft, and taper bushings, TorqLOC® disassembly is fast and easy. The same bolts used for assembly are used for disassembly.

Not only does TorqLOC® reduce your maintenance headaches, it also reduces energy costs by eliminating belts, chains, and sprockets.

SEW
EURODRIVE



Schaeffler Engineering Solutions for Medical Technology

How breakthroughs go from the drawing board to the operating room

Got a great idea that will revolutionize a patient's experience in the operating room? Not sure how to turn it into reality?

Talk to us.

For over 100 years, Schaeffler has been in the business of developing and supplying bearing solutions that safely and efficiently support moving machine parts. When it comes to products that provide movement in medical technology applications, Schaeffler – together with our world-renowned INA, FAG & Barden brands – has decades of experience as both an engineering partner as well as a dependable supplier. We offer:

- Comprehensive, application-driven engineering support and solutions throughout all phases of the product life cycle
- State-of-the-art manufacturing technologies and cutting-edge materials & surface coatings
- An expansive portfolio of nearly 40,000 products, ranging from standard bearings and mechanical components to sophisticated, smooth-running mechatronic systems

Schaeffler engineering: greater than the sum of our parts.

Need more details?
Contact a Schaeffler design engineer
at 803-396-3643 or info.us@schaeffler.com
www.schaeffler.us

©2013

Superior-quality products.
Comprehensive reliable solutions.

