

Mix and Match Mechatronics

Smart technology thrives in heavy industrial market

Matthew Jaster, Senior Editor

Mechatronics simplifies traditional engineering concepts across most industrial segments.

By combining mechanical, electrical and computer technology into a single, integrated solution, products become systems that are more efficient, reduce operator error and cost less to manufacture.

“There is a significant trend in heavy industry to migrate away from hydraulic systems towards electromechanical types. In the right application, electromechanical systems can offer many benefits such as reduced energy consumption and/or energy regeneration, accurate and repeatable positioning, safety and predictive maintenance solutions,” said Richard Hansen, senior automation engineer at Bosch Rexroth.

The mechatronics field is becoming more relevant as engineers blur the lines between mechanical and electrical engineering solutions. “There was very little talk of mechatronics in general manufacturing 20 years ago,” said Craig Hooker, director BU Production Machinery, NA at Schaeffler. “Now the push toward Industry 4.0 and the Industrial Internet of Things (IIoT) has made these integrated concepts more of an engineering necessity moving forward.”

Bosch Rexroth Adapts, Reacts and Integrates

So how are mechatronic solutions being applied in heavy industry today? “Electromechanical systems offer great control of machine function. Our linear drive components can achieve positioning accuracies in the single digit micron range when coupled to Bosch Rexroth motors and drives,” Hansen said. “These motors and drives use sophisticated acceleration profiles that can incorporate jerk for smooth starts and stops when required.”

This type of functionality yields greater control in heavy industrial applications that move large masses, ac-

ording to Hansen. “Greater control gives the user better quality at every step of production by allowing for data capture of all critical aspects of machine function. This data can be very useful for predicting and preventing product defects before they hit the market and/or predicting when machine maintenance is required (another asset for quality assurance).”

Bosch Rexroth has recently developed a Heavy Duty Electromechanical Cylinder (EMC-HD). This cylinder mimics the size and shape of certain traditional hydraulic types but incorporates highly efficient ball or planetary roller screws to produce thrust



Assembly of the EMC-HD. Notice the size of the belt side drive and motor on the right hand end of the actuator that is on the table behind the one being worked on! The scale of this actuator in relation to the workers in this shot helps emphasize the heavy duty nature of the product and large magnitude of forces it can handle. All parts shown are supplied by Bosch Rexroth.

Precision and rigidity are a must in today's heavy machine industries. Bosch Rexroth roller rail and ball screw components offer best in class capacity and durability; helping builders keep up with customers' ever increasing demands and push the traditional limits of machine capabilities. This is well evidenced by this vertical machining center example; where the demand of a large scale overhung payload must be supported and controlled.

forces up to 290,000 N. When coupled to a Bosch Rexroth servomotor, drive and control, the benefits previously mentioned are all achievable. "Having an electromechanical solution that can achieve forces historically reserved only for hydraulic solutions is proving highly desirable to many customers," Hansen explained.

Operating costs in heavy industrial applications are a significant factor. "These systems only use energy when there is demand for use and can also allow for the recapturing of energy into a reserve bank for future use. We've all heard of regenerative braking used on hybrid cars; this is essentially the same



There was little talk of **MECHATRONICS** in general manufacturing 20 years ago. Now the push toward Industry 4.0 and the Industrial Internet of Things (IIoT) has made these integrated concepts more of an engineering necessity moving forward."

concept applied to industrial equipment. Energy that would typically be lost in a form of heat is recaptured and reused, saving costs for the machine owner," Hansen said.

Another benefit that comes to mind is the flexibility of the system. "Servo controls allow the system to be easily adapted on the fly within a flexible manufacturing cell or it can be repurposed to fit a new application once the original design application's life has ended," he added.

Safety plays another key role in mechatronic design. When a full Bosch Rexroth mechatronics solution is offered, the customer can rely on the Safety On Board features of the servo drive. Bosch Rexroth's Safe Torque and Safe Motion are just two examples and allow the machine programmer to enable different safety protocols depen-

dent on the trigger that can protect the operator, the equipment and the product itself. "Ensuring the safety of the machine operator is always the top priority, but if this can be done while still ensuring the integrity of the machine and material it is of great benefit to the customer by reducing downtime and scrap material costs," Hansen said.

Currently, Bosch Rexroth is seeing a lot of potential in offering customers subassemblies that may range from a simple single axis linear actuator to a multi-axis robot. "Many of our customers run lean organizations and often their expertise is in the complete machine solution, not necessarily the motion systems that lie within. We offer design and build services of linear motion and assembly components that complement our customers' resources."



Schaeffler Doubles Down on Mechatronic System

Schaeffler has two focused areas in mechatronics including actuation and sensorized bearings. The thrust of this changing technology is blending different engineering disciplines together to create more efficient systems. "Due to the limitations of hydraulic systems, we're expanding our product line to include designs that offer high load carrying capacity and a high power densi-

ty," Hooker said. "Our planetary screw drive PWG is one example of this."

Screw drives include a threaded spindle and a threaded nut. Due to the rotation of the spindle, the nut moves in a linear manner on the spindle and thus converts the rotary motion of the drive into linear motion. It is rigidly connected to the adjacent construction and gives axial displacement or positioning of the component. The main load direction of screw drives

is axial, but radial load is not permissible. The screw drive can be subjected to high dynamic axial load.

Schaeffler's PWG screw drives are characterized by a very high performance density. Force is transmitted via the flanks of the rollers, spindle and nut. Due to the large number of contact points, a very high axial load carrying capacity is achieved. Due to the very small pitch values, high axial operating forces can be achieved with small drive units (without a gearbox).

The PWG generates 2,200 N of axial force from only 40 Ncm with an overall pitch of 0.75 mm. Consequently, very high axial forces can be achieved even with small motors. Schaeffler's PWG makes it possible not only for actuators driven by electric motors with a high power density, long rating life, and low maintenance outlay to be developed, but also for low-cost motors to be used. The electric drive can be easily integrated using a feather key connection on the outside diameter of the spindle nut.

The applications for the PWG include solar power, wind power, sheet metal forming, sheet metal bending machines, locking cylinders for plastic injection molding machines, riveting



www.circlegear.com

Circle Gear and Machine

1501 South 55th Ct. • Cicero, IL 60804
Ph: 708-652-1000 • Fax: 708-652-1100

WE'VE EXPANDED!



EQUIPMENT PURCHASES

- Luren LFG-8040 Verticle Gear Profile Grinder
- Gleason 463 spiral/hypoid gear tooth grinder

FACILITY

- Purchased 77,000 sq ft building, expanding to 122,000 sq ft

STRATEGIC PLANS

- Continued growth in spiral bevel/hypoid marketplace
- Expand gearbox service and overhaul business

GEARBOX REPAIR SPECIALISTS

- Prompt, accurate quotations
- Competitive pricing
- Quality repairs/rebuilds

Quality Reducer Service

1501 South 55th Ct. ■ Cicero, IL 60804
708-354-8080 | FAX: 708-652-1133

WE SERVICE ALL TYPES OF INDUSTRIAL GEARBOXES

www.qualityreducer.com



Schaeffler's torque sensor technology is already being utilized in certain agriculture applications.

and cutting devices, and in adhesive metering systems. The PWG is already in volume-production use in clutch actuators for the automotive industry.

On the bearing side, Schaeffler offers an intelligent roller bearing solution that measures lubrication status, wear particles, temperatures, vibration, force, torque and speed. "Different modules can do different things," Hooker said. "We're able to apply sensors right where the torque is being transmitted as a bearing is often the central part of the machine design."

This torque sensor technology is already being used in agricultural machinery. Fertilizer spreaders, for example, include FAG torque measurement units integrated directly into the drive hub. They accurately measure the actual fertilizer flow during the spreading process using contactless technology. Clogging and blockages at the dosing gate can be identified. "A similar application would be the distribution of salt on icy roads," Hooker added. "Here, the torque sensor can give the driver a more accurate measurement of the salt needed to adequately cover the road without creating more waste."

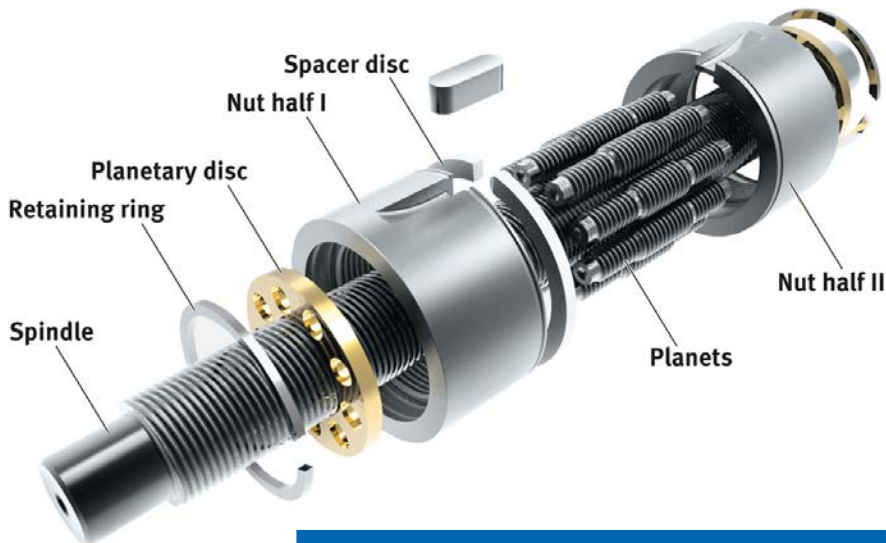

In the Schaeffler planetary screw drive (PWG) design, the spindle and planetary gears are manufactured using forming methods.

For Related Articles Search

mechatronics

at www.powertransmission.com

INNOVATIVE RACK & GEAR



Gear rack specialists with state-of-the-art gear rack production capabilities including our most recent acquisition; Gleason-Saikuni HR-2000 CNC rack milling machine with hard-milling after heat treat capabilities up to 65 Rc hardness (producing impressive tooth finishes and accuracies comparable to rack grinding).

We will happily demonstrate samples produced for the most demanding of needs in aerospace, automation, off-highway equipment, defense, energy, machine tool, medical and others.

- Custom SPUR and HELICAL racks from a variety of materials
- Precision Quality up to AGMA 12
- Unique Tooth Configurations
- FINE and COARSE pitch (254 D.P. – 0.5 D.P.; 0.10 Module – 50 Module)
- Hard-cut up to 65 Rc and soft-cut up to 40 Rc
- 32" Face width and up to 288" lengths through resetting
- Prototype & Production quantities
- Breakdown Service Available
- Reverse Engineering
- Heat Treating & Plating
- Complete CNC Machining



630.766.2652

fax: 630.766.3245

www.GEARACKS.com

info@gearacks.com

365 Balm Court, Wood Dale, IL 60191

Mechatronic Applications with SKF

Jean-Pierre Collognat, linear and actuation technology business leader at SKF, also described planetary roller screws as some of the newest mechatronic technology for heavy industrial applications. "These planetary roller screws are built into electro-mechanical linear actuation in conjunction with high torque electric motors," he said. "They offer high load carrying capacity and long service life for heavy duty applications. SKF's latest generation of Ultra Power roller screws provide a load carrying capacity increased by 60 percent versus traditional planetary roller screws. Ultra Power roller screws advantageously replace hydraulic cylinders in industrial grade applications, with the additional benefits of energy savings, precision and flexibility of electric controls."

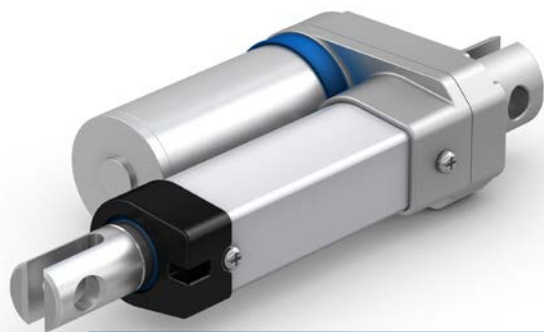

SKF electromechanical actuator CAHB family features robust metal gears and corrosion-resistant housings.

Mechatronic solutions are advantageous for several reasons in heavy industry, according to Collognat. "Some of these include a general trend toward increased energy efficiency and environmental consciousness, lower total cost of ownership and improved functionality." The benefits for considering mechatronic solutions vary by industry.

Collognat discussed particular industrial segments where mechatronic solutions would offer significant upgrades to older equipment or individual components:

Plastic Injection Molding: Energy efficiency, cleanliness, productivity.

Broaching: Electro-mechanical machines offer greater flexibility for producing various parts (easier change-over.) EM solution offers higher machine stiffness, constant acceleration and speed, resulting in higher accuracy and better part surface finish. Tool life is greatly increased. EM broaching machines have a smaller footprint and present lower environmental risks.

Stamping presses: Better stamping force control, for greater part accuracy.

SKF's LEMC is a modular electromechanical cylinder that consists of a linear unit, motor adapter, limit switch and motor and controller.

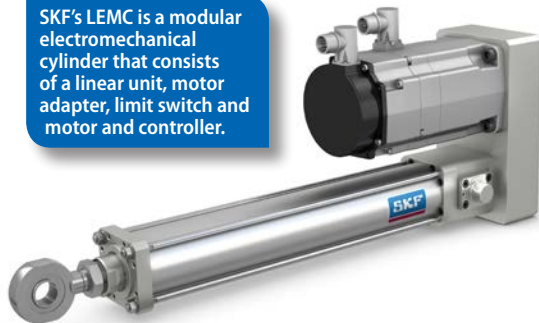

Assembly presses: Full control of the assembly process, with force and displacement monitoring as well as the recording of process parameters in real time.

Factory automation: Many industries striving for the fluid-free factories. Motivations to look for electro-mechanical solutions: Energy efficiency, Total Cost of Ownership, flexibility, preciseness, functionality, controllability, productivity, speed, noise reduction, safety, reliability, reduced maintenance, space saving.

Oil & Gas: Customer motivations: EM solutions ease of use, controllability, environmental impact, response time (example closing a subsea valve is way easier with an EM solution than running a hydraulic line,) safety, compactness (down-hole tools), reliability.

Taking the Next Step

The role of online mechatronic design and simulation will make huge strides in the next decade, according to Hansen at Bosch Rexroth. It is common to see online model configurators with all automation component suppliers. The trend and demand will continue for these suppliers to offer their potential customers design and simulation services directly on their website.

"This not only allows the customer to build a 3D model, but also develop motion simulation right there to easily allow the engineer to determine if the product meets the application's needs. This may not be only a graphical representation, but could ideally result in real programming that can be utilized

for commissioning once the physical system arrives at the customer's site. Many robotic suppliers already offer this type of solution. This type of offering can also prove invaluable when presenting and communicating the intended solution, before any components are purchased, with the end user to ensure all parties understand and recognize the application needs," Hansen said.

Collognat at SKF believes mechatronics for industrial grade applications will experience an annual growth rate around 10 percent based on various figures in IMS reports. "More industries will embrace the environmental benefits of EM technology and total cost of ownership will go down with

increased competition, reduced costs of servo technology, etc," he said.

Hooker at Schaeffler said the interest in mechatronics continues to evolve. "I don't think we're going to see any earth shattering changes in mechatronic applications, I think we'll see small incremental changes that will make industrial systems smaller, more efficient and easier to use." **PTE**

For more information:

Bosch Rexroth
Phone: (800) 739-7684
www.boschrexroth.com

Schaeffler Group USA, Inc.
Phone: (803) 548-8500
www.schaeffler.us

SKF USA Inc.
Phone: (267) 436-6000
www.skf.com