

Power Transmission Engineering®

FEBRUARY 2015

So You Wanna **BUY** SOME **GEARS?**

THE **FIVE GOLDEN RULES** OF GEAR BUYING



A **CASE STUDY** IN **AUTOMATION**

AUTOMATE **2015** PREVIEW

TECHNICAL ARTICLES ON
GEARS, BEARINGS, SOFTWARE,
PUMP DRIVES AND MOTORS

Precision Gearboxes

for Servomotors

SureGear® Precision Servo Gearboxes

The SureGear PGA series of high-precision servo gear reducers is an excellent choice for applications that require accuracy and reliability at an exceptional value.

These planetary gearboxes, now available in both right-angle and inline versions, have a thread-in mounting style, along with precision and torque capacity that is best in class.

- **NEW right-angle models are perfect for space-limited applications**
- Industry-standard mounting dimensions
- Best-in-class backlash
- Four gear ratios available (5, 10, 15, 25:1)
- Helical-cut planetary gears for quiet operation and reduced vibration
- Uncaged needle roller bearings for high rigidity and torque
- Adapter bushing connection for simple and effective attachment to SureServo motors
- Maintenance free: no need to replace the grease for the life of the unit
- At nominal speed, service life is 20,000 hours
- Can be positioned in any orientation
- 5-year warranty
- Starting at: **\$398.00** (70mm Frame - PGA070-05A1)



Example models shown

\$398.00
(PGA070-05A1)

Suregear®

\$674.00
(PGB070-05A1)

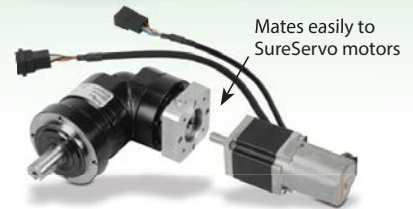

Mates easily to SureServo motors



Research, price, buy at:

www.automationdirect.com/motion-control

Use SureGear with our practical SureServo systems

start under \$1,000**



The SureServo family of brushless servo systems from AutomationDirect is fully digital and offers a rich set of features at dynamite prices.

Beginners to experienced users can take advantage of this easy-to-use family for as little as \$986.00** (100W system).

** All components sold separately.

- Eight standard systems from 100 W to 3 kW
- Use with most AutomationDirect PLCs or any other host control
- Drives feature on-board indexer and adaptive tuning modes
- Free set-up software
- 2 year warranty

CHECK OUT OUR PRICES

Servo Systems	AutomationDirect Price/Part Number	VS.	Allen-Bradley Price/Part Number
Digital Servo Drive	\$488.00 SVA-2040		\$1,340.00 2098-05SD-005
100W Servo Motor with connectorized Leads	\$325.00 SVL-201		\$558.00 TLY-A130T-HK62AA
Breakout Board Kit for CN1 Control Interface	\$94.00 ASD-BM-50A		\$263.00 2090-U3BK-D4401
10' Motor Feedback Cable	\$49.50 SVC-EFL-010		\$90.00 2090-CFBM6DF-CBAAD3
10' Motor Power Cable	\$29.50 SVC-PFL-010		\$101.00 2090-CPBM6DF-16AAD3
Configuration Software	FREE SV-PRO*		\$75.00 2098-UWCPRG
Complete 1-axis 100W System	\$986.00		\$2,427.00

*SureServo Pro software is FREE when downloaded and is also available for \$9.00 on a CD
All prices are U.S. list prices. AutomationDirect prices are from October 2014 Price List. The Allen-Bradley 100W system consists of part numbers shown in table above with prices from www.wernerelectric.com 10/29/2014.

Order Today, Ships Today!



AUTOMATIONDIRECT.com
1-800-633-0405

the #1 value in automation

* See our Web site for details and restrictions. © Copyright 2014 AutomationDirect, Cumming, GA USA. All rights reserved.

Power Transmission Engineering®

FEBRUARY 2015



[28]

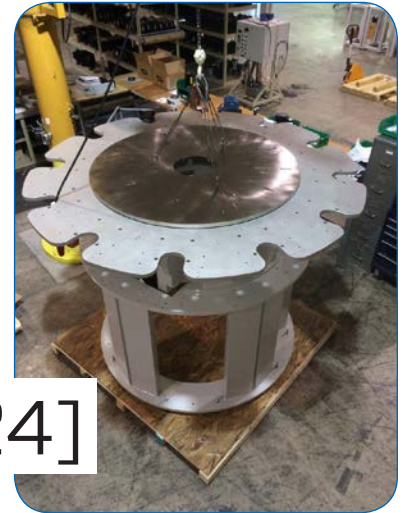

[24]

FEATURE ARTICLES

- [18] **The Five Golden Rules of Gear Buying**
It helps to know what you're talking about.
- [24] **Innovative Design Solves Automotive Parts Assembly Challenge**
Weiss North America helps Alpha Integration automate 24/7 parts assembly system.
- [28] **A Quasar Ride to Automate 2015**
75,000 square feet of robotic and automation glory.



[64]

TECHNICAL ARTICLES

- [34] **Ask the Expert**
Gear Rating
- [36] **Gear Wear Calculation and Prediction**
A calculation method used to predict where and when local wear will occur on a tooth flank.
- [40] **Desktop Engineering — How to Calculate Dynamic and Static Load Ratings**
Understanding of how capacity ratings and subsequent life calculations are generated for bearings.
- [44] **Variable Speed Pump Drives for Industrial Machinery — System Considerations**
The changing landscape of hydraulic drives is leading many fluid power specialists to quickly adapt to using variable speed pump drives.
- [48] **Gear Fault Diagnosis by Motor Current Analysis: Application to Industrial Cases**
Advantages and drawbacks of MCSA-type techniques are presented and discussed.

Vol. 9, No. 1. POWER TRANSMISSION ENGINEERING (ISSN 2331-2483) is published monthly except in January, May, July and November by Randall Publications LLC, 1840 Jarvis Ave., Elk Grove Village, IL 60007, (847) 437-6604. Cover price \$7.00. U.S. Application to Mail at Periodicals Postage Prices is Pending at Palatine, IL and at additional mailing offices. Send address changes to POWER TRANSMISSION ENGINEERING, 1840 Jarvis Ave., Elk Grove Village, IL 60007.

Randall Publications LLC makes every effort to ensure that the processes described in POWER TRANSMISSION ENGINEERING conform to sound engineering practice. Neither the authors nor the publisher can be held responsible for injuries sustained while following the procedures described. Postmaster: Send address changes to POWER TRANSMISSION ENGINEERING, 1840 Jarvis Avenue, Elk Grove Village, IL, 60007. ©2015 Contents copyrighted by RANDALL PUBLICATIONS, LLC. No part of this publication may be reproduced or transmitted in any form or by any means, electronic or mechanical, including photocopying, recording, or by any information storage and retrieval system, without permission in writing from the publisher. Contents of ads are subject to Publisher's approval.

Power Transmission & Linkage Components



Scan to see these products

SEE US AT PROMAT BOOTH 5326

J.W. Winco offers power transmission components as part of its immense offering of standard machine components for industry. Explore our full line on our website www.jwwinco.com or contact us with your application requirements.

2815 S. Calhoun Road
New Berlin, WI 53151
Phone: 800-877-8351
Fax: 800-472-0670
Sales@jwwinco.com



J.W. WINCO
INC.

Power Transmission Engineering

VOL. 9, NO. 1

[04] PTEExtras

Latest online videos, e-mail newsletters and social media

[06] Editorial

Maximizing Your Power Transmission (Engineering)

[08] Product News

What's new and worth knowing about

[52] Industry News

The who, what and where

[60] Events/Calendar

March 23-26 – Automate 2015

March 24-26 – 2015 Gearbox CSI: Forensic Analysis of Gear & Bearing Failures;

April 29-May 1 – 2015 AGMA/ABMA Annual Meeting

[62] Advertiser Index

Advertiser contact information.

[63] Subscriptions

Free subscriptions, anywhere in the world.

[64] Power Play

The Science Fiction Addiction



Transmission expert.



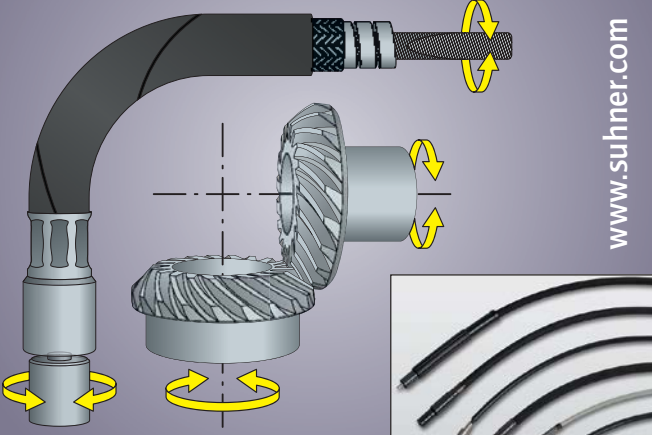



www.suhner.com

Flexible Shafts & Spiral Bevel Gears

Two different ways to transmit rotary motion.

SUHNER Manufacturing Inc. · Rome, GA 30161
Phone: 706-235-8046 · info.usa@suhner.com



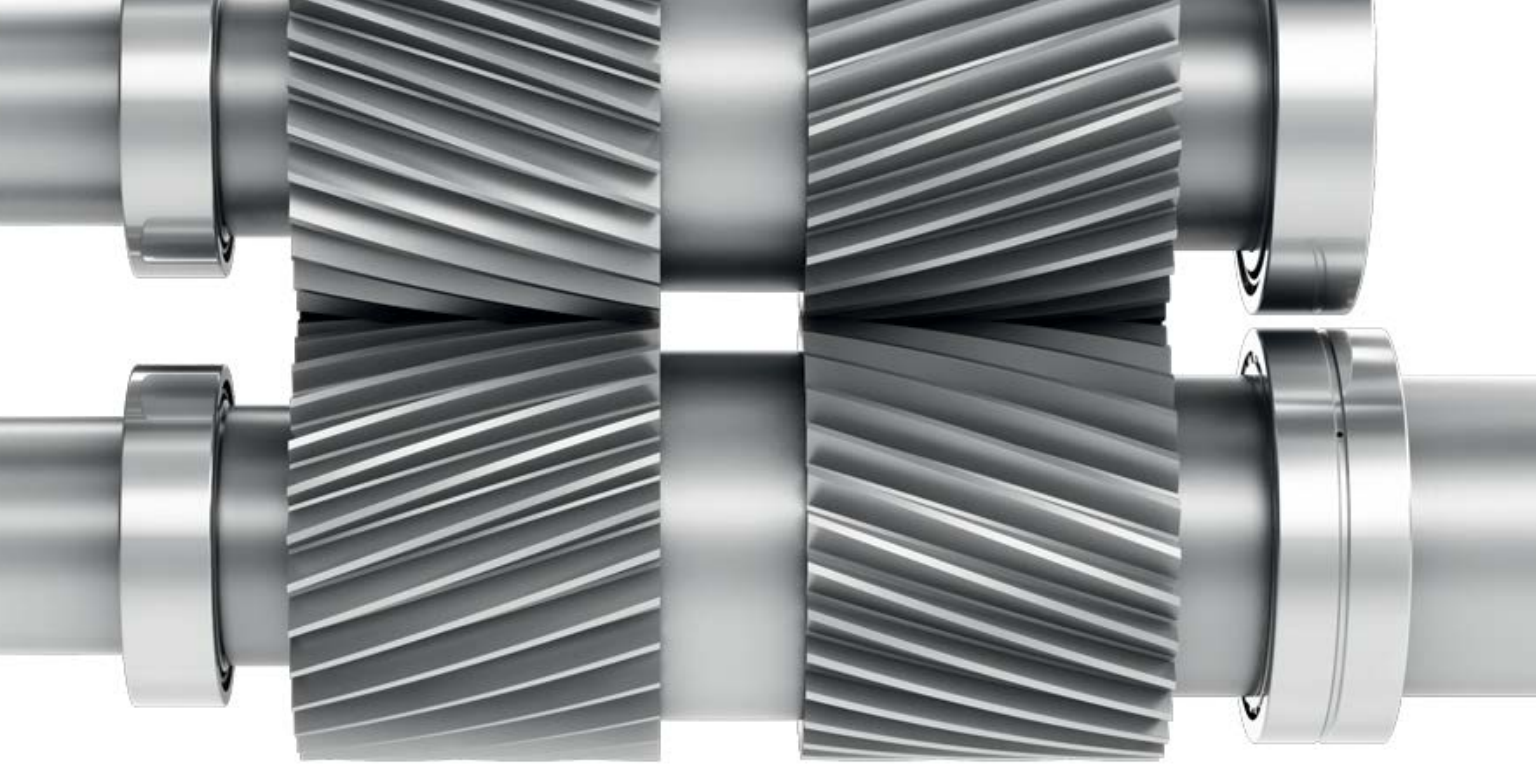

More torque. Less friction.



Enhance gear unit reliability and improve performance
Upgraded SKF Explorer self-aligning bearings have enhanced wear and contamination resistance, and are better able to sustain external loads – up to 20% more load for a given life of a gear unit.

Optimize gearbox units with upgraded SKF Explorer bearings

A robust solution for harsh and demanding gearbox environments, upgraded SKF Explorer bearings enable a gear unit to transmit more torque, sustain higher external loads, or even be downsized to improve cost efficiency.

In addition, these bearings provide substantially lower friction than other bearings. In fact, the friction can be reduced by 30% compared to the competition, enabling the gearbox to run cooler and more efficiently.

With expertise in bearings, sealing, and lubrication solutions, SKF engineers can add value to the complete gear unit by enhancing reliability and performance, while improving the cost-effectiveness of the complete solution.

For more information, please visit skf.com or contact your local SKF representative.



Visit us at Hannover
Messe 2015, Hall 22

The Power of Knowledge Engineering

SKF®

More Suppliers, More Choices

We're constantly improving the online **Buyers Guide** at *powertransmission.com* by adding new suppliers of gears, bearings, belts, clutches, couplings, motors and other mechanical power transmission components. See who's been added recently:



The Bearings Blog

Beginning in January, our regular contributor Norm Parker, bearings specialist at GM, has begun writing a weekly blog focusing on bearings. So if you have an interest in bearings specification, bearings purchasing, machine design, bearing life or any of the technical aspects of bearings, we encourage you to visit and read: www.powertransmission.com/blog



The Gear Technology Blog

For more than a year, *Gear Technology* technical editor and overall gear guru, Chuck Schultz, has been offering his insight over at our sister publication's website. Visit the *Gear Technology* blog if you have an interest in gear design, gear manufacturing or gears in general: www.geartechnology.com/blog



Back to Basics: Gearbox Types

Brevini presents a back-to-basics video that describes the four major types of gearboxes on the market today, detailing each type's strengths and weaknesses. Learn which type of gearboxes are used for which purposes, and why. Watch the video at www.powertransmission.com

Stay Connected with Social Media



Follow us on Twitter
twitter.com/#!/PowerTransMag



Connect with us on LinkedIn
www.linkedin.com/groups/Power-Transmission-Engineering-PTE-2950055

Renew Your Free Subscription



Subscribe Online
www.powertransmission.com/subscribe.htm

Power Transmission Engineering

Randall Publications LLC
1840 Jarvis Avenue
Elk Grove Village, IL 60007
Phone: (847) 437-6604
Fax: (847) 437-6618

EDITORIAL

Publisher & Editor-in-Chief
Michael Goldstein

publisher@powertransmission.com

Managing Editor & Associate Publisher
Randy Stott

wrs@powertransmission.com

Senior Editor

Jack McGuinn

jmcguinn@powertransmission.com

Assistant Editor

Erik Schmidt

erik@geartechnology.com

Editorial Consultant

Paul R. Goldstein

ART

Art Director

David Ropinski

dropsinski@powertransmission.com

ADVERTISING

Advertising Sales Manager & Associate Publisher

Dave Friedman

dave@powertransmission.com

China Sales Agent

Eric Wu

Eastco Industry Co., Ltd.

Tel: (86)(21) 52305107

Fax: (86)(21) 52305106

Cell: (86) 13817160576

eric.wu@eastcotec.com

Materials Coordinator

Dorothy Fiandaca

dee@randallpublications.com

DIGITAL

Content Manager

Kirk Sturgulewski

kirk@powertransmission.com

CIRCULATION

Circulation Manager

Carol Tratar

subscribe@powertransmission.com

RANDALL PUBLICATIONS STAFF

President

Michael Goldstein

Accounting

Luann Harrold





ORDER'S UP.



As simple as ordering lunch? Well, not quite, but close.

- Arrow Gear offers the broadest range of STOCK GROUND TOOTH Spiral Bevel Gears.
- Up to 16 inch dia., lapped and **NOW!! GROUND TOOTH** in stock for **IMMEDIATE DELIVERY.**
- Visit ARROWGEAR.COM for your stock gear solutions.

Now that's simple.



**ARROW
GEAR
COMPANY**

www.arrowgear.com

630.969.7640

Maximizing Your Power Transmission (Engineering)

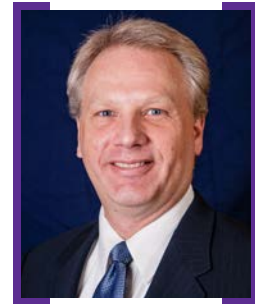

Engineers are often challenged with the seemingly impossible task of doing more with less.

Customers want more power transmitted in a smaller space, they want more efficient designs, and, of course, they want to spend less money. So engineers are always looking for ways to squeeze the most out of their mechanical systems. They're constantly working to maximize power density, increase energy efficiency and reduce costs to meet their customers' needs.

Here at *Power Transmission Engineering*, we understand. Like you, we have to work hard to continuously improve what we offer our customers. Only in our case, it's not torque or efficiency we're maximizing. It's information and the way it's delivered.

Over the past several months, we've implemented a number of changes that will help us significantly increase not only the amount of information we provide, but also its quality. Chief among those improvements is an increase in staff. In publishing, we increase throughput and improve quality by hiring smart, capable people. You may have noticed their names on our roster.

Erik Schmidt, Assistant Editor, has already begun making a big impact for us. In his article on gear buying (p.18), Erik interviewed gear industry experts to compile the five tips every gear buyer should follow. He's also prepared a preview of the Automate 2015 show (p. 28) that takes you beyond the mundane facts and figures. I encourage you to read both of those articles, because we're confident that you'll find Erik's writing to be both informative and entertaining.

We've also hired a new digital content manager, Kirk Sturgulewski, whose role is to make sure you receive our information in whatever format you prefer. So whether you subscribe to our digital edition, our e-mail newsletters or our product alerts, Kirk is here to make sure the information you receive is formatted properly for the device you're reading it on. He's also charged with making improvements to our website, adding features and making it more user friendly. You'll see some of those improvements over the coming months.

Also, beginning in January, we launched a blog on *powertransmission.com*, featuring our regular contributor Norm Parker, who is a bearings specialist at General Motors. Norm has been a frequent author of technical articles and feature articles, as well as a regular expert in our "Ask the Expert" column. Now, Norm is bringing his expertise online, with a weekly blog on bearings. His topics range from "Just How Big Are the Biggest Bearings" to "Treat Your Suppliers Well" and some of the more technical aspects of machine design. If you regularly work with bearings, you won't want to miss out on Norm's insight.

The blog is designed to be interactive, so if you have a bearing-related question or want to chime in on one of the topics Norm has introduced, feel free. The more people that participate, the more valuable the resource becomes for everyone.

All of these additions are designed to maximize the information we bring you, and to ensure that it's the information you need, delivered in the way you need it. We have a number of other projects we're working on, and we hope to continue expanding our product range and offerings.

Of course, all of this is designed to better serve you, and your continued support helps ensure that we'll continue adding content and making improvements. One of the best ways you can show that support is by keeping your subscription fresh. If you haven't renewed your subscription lately, you'd be doing us a big favor by going to *www.powertransmission.com* and clicking on "Subscribe" at the top of the page.

Finally, we'd like to thank our advertisers, without whom none of these improvements would be possible.

A handwritten signature in black ink that reads "Randy Stott". The signature is written in a cursive, flowing style.



Sterling Instrument
Your Partner in Innovation

Precision Gears and Gear Assemblies

EXPLORE | DESIGN | BUY ONLINE

www.sdp-si.com/precision



Design and production of precision gears, gear assemblies, gearboxes, differentials, speed reducers and other motion control products.

Engineering and Manufacturing Expertise • Prototype to Large Production Runs for OEMs

50 years of proven quality, reliability and service to aerospace and defense, satellites, military, medical, industrial and commercial OEM.

Customized Design and Technical Support
AS9100C Registered | Boeing Certified

Sterling Instrument

2101 Jericho Turnpike, New Hyde Park, NY 11040
Tel. (516) 328-3300 • sdp-sisupport@sdp-si.com
www.sdp-si.com

Sturdi-USA

TO DISTRIBUTE SHAFT REPAIR SLEEVES

Sturdi-USA has recently been selected by Taiwan-based Sturdi Sealing Tech as the exclusive U.S. distributor of its Sturdi shaft repair sleeves, a kit for repairing worn shafts. Each kit includes a thin, stainless steel sleeve and a basic installation tool.

“Sturdi shaft repair sleeves are highly engineered components that press-fit onto a shaft to quickly, easily, and economically repair and even deter damage to shafts and spindles,” said Steve Kroll, president of Sturdi-USA, in Houston, TX. “Sturdi shaft repair sleeves provide a protective seal running surface and reduce the need for complex and expensive shaft machining, repair or replacement.”

Engineered for automotive and industrial applications, the sleeves are designed for ambient-temperature interference fit and are available in various sizes and finishes.

There are four benefits to using Sturdi shaft repair sleeves as an alternative to repairing or replacing a damaged shaft. Sturdi shaft repair sleeves reduce equipment down time, as they are installed without having to remove the shaft. The sleeves are thin, so there is no need to change seal size. The sleeve’s surface is machined without directionality, making it more wear



resistant and often resulting in a better finish than that of the original shaft. Sturdi shaft repair sleeves have a durable, corrosion-free surface, which creates a sealing surface conducive to extending the life of the seal.

Grooving wear on a shaft can require re-machining, such as metalizing or regrinding, or it can result in the shaft having to be replaced. Sturdi shaft repair sleeves are pushed over the worn running surface. A standard depth installation tool is supplied with the sleeve.

Sturdi shaft repair sleeves are suited for applications in industries such as aerospace, agricultural equipment, automotive, construction equipment, food and beverage processing, marine, material handling, mining and natural

resources, oil and gas, pharmaceutical processing and power generation.

Automotive applications include, but are not limited to, engine crankshaft front and rear, transmission front and rear; transfer case input and output shaft, pinion differential/yokes, harmonic balancer, camshaft, timing cover; wheel; steering sector/shift shaft.

Industrial applications include, but are not limited to, industrial gearboxes and motor shafts, industrial pumps, crushers, conveyors, motors, reducers, fans, valves and pumps.

For more information:

Sturdi-USA
Phone: (713) 784-8504
www.sturdi-usa.com

SKF

INTRODUCES SENSOR BEARING WITH EMC FILTER

A newly introduced SKF sensor bearing equipped with an electromagnetic compatibility (EMC) filter offers protection against potential damage to the bearing’s sensitive electronics from power surges or electric discharges, most notably in AC electric motor applications. The EMC filter is integrated

in-line with the sensor bearing’s cable to protect the Hall sensor and other electronics used in the bearing and can help improve bearing reliability and service life.

The new sensor bearing with EMC filter provides a variety of monitoring capabilities for applications across many industries. Depending on application, SKF sensor bearings can measure a range of operating conditions, such as speed, position and direction of a shaft, among others.

All SKF sensor bearings serve as ready-to-mount, plug-and-play units incorporating a shielded sensor and deep groove ball bearing. The sensor body, impulse ring and bearing are

mechanically attached to each other to form a unit retaining tight tolerances within the bearing.

SKF sensor bearings can deliver benefits before and after installation. Their design helps reduce development times and costs associated with manufacturing and assembly; a reduced footprint for the all-in-one units can allow for downsizing and weight reductions; and durable components and materials promote sensor bearing unit performance over time.

For more information:

SKF USA, Inc.
www.skf.com





Gearing your past to power your future.



Breakdown Services

We understand the urgency of meeting critical deadlines. We offer our customers expedited services without sacrificing quality.

Heat Treatment

Our in-house heat treat facility performs a full range of services that include annealing, carburizing, and thru hardening.



B&R Machine and Gear Corporation is a full service gear manufacturing facility driven to power your equipment with reliable and durable gears that are built to perform and last. Find the perfect mesh. No matter the gear, we've got you covered.

VISIT OUR WEBSITE BRGEAR.COM FOR MORE INFORMATION

Screw Jacks

The Zimm series offers all the connecting, drive, and safety components from a single source.

Download the product overview and application guide today!

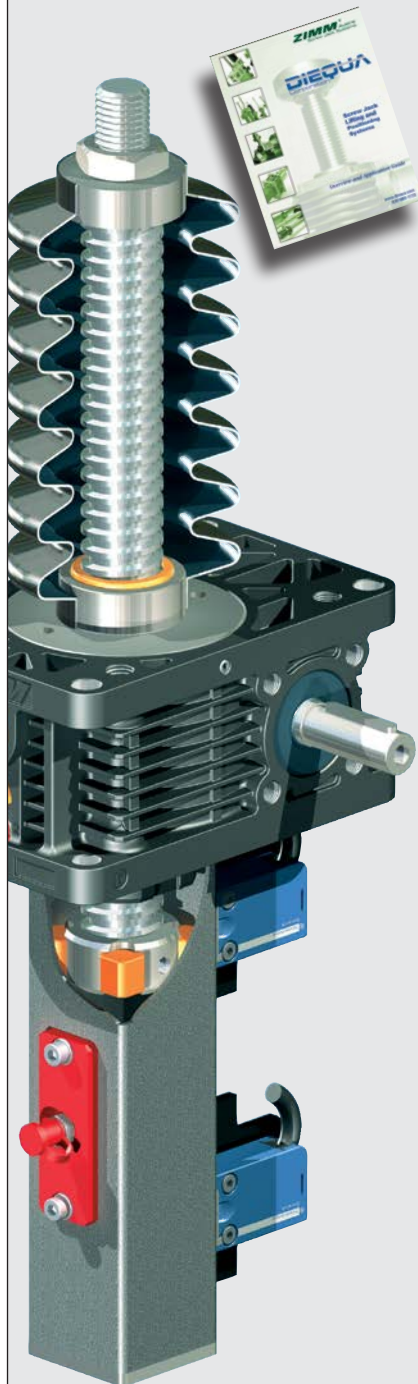

See our complete product line!

DIEQUA
Corporation

www.diequa.com
630-980-1133



Stafford

INTRODUCES NEW BORE SHAFT COLLARS

A line of large bore shaft collars and flange mounts for construction equipment, processing and mining conveyors, energy applications and more are available from Stafford Manufacturing Corp. of Wilmington, Massachusetts.

Stafford large bore shaft collars are designed for heavy-duty drive system applications and are offered in one- and two-piece clamp-type configurations with smooth round, square, hex, and threaded bores. Available in a variety of materials with bore sizes up to 12" I.D., these fully split collars can incorporate keyways and slots on the bore, tapped mounting holes, spanner wrench holes, and other features on the face or O.D.

Supplied with alloy socket cap screws up to 1-8" for optimum holding power, Stafford large bore shaft collars can incorporate multiple- and extra-large screws for extreme applications. Flange mount shaft collars are also offered in large sizes and can incorporate drilled and tapped mounting holes in any pattern, along with other customer specified modifications.

Stafford large bore shaft collars and flange mounts are priced according to material and quantity; available from stock up to 6" I.D. and up to 12" as specials. Price quotations are provided upon request.

For more information:

Stafford Manufacturing Corporation
Phone: (800) 695-5551
www.staffordmfg.com

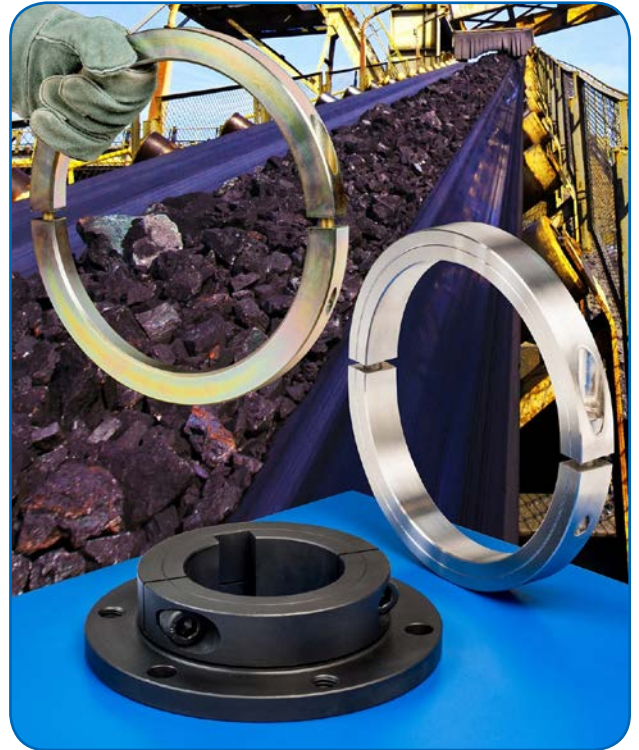



HIGHEST QUALITY

LEADER IN GROUND TOOTH SPIRAL BEVEL GEARS



OUR BRAND-NEW, STATE-OF-THE-ART FACILITY IS AS9100 CERTIFIED, PRODUCING THE HIGHEST QUALITY SPIRAL BEVEL, HYPOID, SPUR, AND HELICAL GEARS.

OUR CLOSED-LOOP SYSTEM, COUPLED WITH OUR GRIND-FROM-SOLID TECHNOLOGY, ENSURE CONSISTENT QUALITY AND QUICK TURNAROUND.

FASTEST DELIVERY

SPIRAL BEVEL AND HYPOID GEARS FROM DESIGN TO DOORSTEP IN AS LITTLE AS FIVE WEEKS.



RAVE GEARS AND MACHINING
TALENT AND TECHNOLOGY DRIVEN

+1 855 RAV GEAR
sales@ravegears.com
WWW.RAVEGEARS.COM

425 STREMPER ST., SEGUIN, TX 78155

LM76

INTRODUCES 'ROLL-SLIDE MINI' CARRIAGE AND RAIL
LINEAR MOTION SYSTEMS

Low cost, "Roll-Slide Mini" carriage and rail linear motion systems are now available from LM76 in lengths from 160 mm (6.30 in.) to 1,200 mm. Travel is from 88 mm (3.46 in.) to 1,128 mm (44.41 in.)

These low-profile linear motion systems are 12 mm (0.47 in.) high and feature quiet running, low resonance, smooth motion, low friction 440c stainless steel roller bearings, low magnetic signature, corrosion resistant stainless steel rails and electroless nickel plated carriages.

The "Roll-Slide Mini" carriage and rail linear motion systems have evenly-spaced mounting holes in the rails and the carriage has four drilled and tapped mounting holes. The maximum load is 80 N (45 pounds) for a single carriage, and the temperature range is -10 degrees to 50 degrees

C. Applications can include camera sliders, sensor carriers, medical, bio-pharmaceuticals, food, defense/aerospace, and manual adjustment mechanisms. As an option the carriage is available with a stainless steel, plastic tipped friction knurled hand stop, and the rails are supplied with end stops. Carriage and rail systems can be ordered with zero clearance for maximum precision.

LM76 manufactures and distributes a broad variety of FDA & USDA compliant bearings and shafting, in inch sizes of 0.25 inches to 1.5 inches, and a FDA and SDA compliant profile rail and slide system that can be integrated into new and existing applications. The bearing options include self-lubricating FDA and USDA compliant self-lubricating (PTFE) composite bearings in a 304 stainless steel shell,



THIN ENOUGH?

BXR Brakes

- Up to 480 in-lbs static
- Up to a 1.125" bore
- 19 watts or less
- Produced for over 10 years

Our Innovative design features a very thin profile, reducing weight and saving space.

For more information:
Call: 800.533.1731
www.mikipulley-us.com



Festo

INTRODUCES A LOW-COST POSITION TRANSMITTER FOR LINEAR ACTUATORS

The new SDAT-MHS T-slot programmable position transmitter from Festo provides the same functionality as position transducers and mechanical potentiometers at a lower price point. These new sensors offer OEMs a flexible solution for sensing the position of pneumatic cylinders. By sensing the magnetic piston, cylinder position can be transmitted to the PLC with repetition accuracy of 0.1 mm.

The five sizes of the Festo SDAT-MHS correspond to the most commonly

used strokes of Festo pneumatic cylinders. The SDAT-MHS detects complete strokes without projecting beyond the end of the cylinder, including full stroke length and end position sensing. In addition to analog position data, the SDAT-MHS also features a programmable digital switching output that can replace an existing cylinder switch.

For more information:

Festo
www.festo.com





and lower cost bearings with a ceramic coated shell and FDA and USDA compliant liner. Bearings are available in closed and open configurations, and are drop-in replacements for all inch sized linear ball bearings

For more information:

LM76
Phone: (413) 525-4166
www.lm76.com

J.W. Winco

INTRODUCES STEEL AND STAINLESS STEEL HINGES

J.W. Winco, Inc., a supplier of standard industrial machine components, recently announced it now offers GN 129.2 steel and stainless steel hinges, in metric sizes.

These RoHS-compliant hinges are used for doors that are flush with the frame on the outside. Once assembled, they cannot be unhinged. Being mounted from the inside, they are suitable for doors and trap doors that must not be detachable from the outside as an anti-tamper device.

Hinges are available in steel, with a zinc-plated, blue passivated finish, European Standard No. 1.4305 stainless steel (American Standard Series

303), or European standard 1.4408 stainless steel (American Standard Series 316). The steel version has a brass, nickel-plated hinge pin and hinge washer; steel hex nut and serrated washer are zinc-plated, with a blue passivated finish. Both stainless steel versions have all stainless steel parts.

For more information:

J.W. Winco, Inc.
Phone: (800) 877-8351
www.jwwinco.com



PRECIPART®

www.precipart.com

CUSTOM BEVEL GEARS

Perfection from prototype to production



631 · 694 · 3100

gearedsolutions@precipart.com



MEDICAL



INDUSTRIAL



AEROSPACE

DieQua offers more gearboxes

plus the experience and expertise to select the best one for your needs.

For Power Transmission

Spiral Bevel Gearboxes



- 9 Sizes
- 1-250 HP Capacity
- Low Backlash Option
- Ratios from 1:1 to 6:1
- Output Shaft Options
- Machined Housings

Worm Reducers



- 7 sizes, 28-110mm CD
- Fret-free Connection
- NEMA or IEC Adapters
- Coupling Input
- Aluminum Housings
- 2-Side Worm Support

Helical Gearmotors



- 1-75 HP Capacity
- Motorized or Adapters
- Right Angle or Inline
- Shaft Mount Designs
- Multi-Stage Ratios
- Modular Design

For Motion Control

Planetary Gearheads



- Precision or Economy
- Inline or Right Angle
- 40-155mm Frames
- Low Backlash
- 1 and 2 Stage Ratios
- Lubricated for Life

Servo Worm Gearheads



- 3 Backlash Levels
- Shafts or Hollow Bores
- Single or Dual Outputs
- 11 sizes, 25-200mm CD
- Capacity: 10-7000 Nm
- 20,000 Hour Ratings

Robot Gear Units



- Zero Backlash
- Precise Positioning
- High Repeatability
- High Stiffness
- Supports Tilting
- 10 Sizes

See our complete product line!

DIEQUA
Corporation

www.diequa.com
630-980-1133



Groschopp

OFFERS ABILITY TO PURCHASE CUSTOM MOTORS ONLINE

Groschopp Inc. is now offering customers the ability to order custom motors and gearmotors online. A recent redesign of Groschopp's website features a number of new functions and abilities that make it easier for them to deliver what customers need in a motor, allowing customers to modify and choose specifications for standard products, online.

The process is similar to shopping for a vehicle on a car dealer website, where a customer first chooses their basic model, then adds different levels of accessories or modifications. Groschopp is one of the few fractional horsepower motor manufacturers to offer such a tool.

These features, combined with Groschopp's ability to build and ship customer-modified gearmotors within two working days, provides a quick turnaround for customers desiring quality, precision engineered gearmotors in a short period of time. There are over 50 modifications to choose from

on the redesigned website, as well as a feature where customers can upload their prints and specifications directly to Groschopp. This will help create a more efficient product selection process by providing sales with all the information needed earlier in the sales cycle to get the customer the best gear motor for their application, sooner.

Another key feature on Groschopp's updated website is the addition of 3-D, rotatable images of motors and gearmotors. These 3-D interactive images will visually highlight the product's design. Additionally, performance curves on product pages will assist engineers in the design process by allowing them to review the specific performance data of each motor and gear motor. It is Groschopp's desire that these features will equip engineers with the information they need to choose the best product for their application.

For more information:

Groschopp, Inc.
Phone: (800) 829-4135
www.groschopp.com

There are **7** days
in a week.

We only
need **2**

STANDARD OR CUSTOM MOTORS IN 48 HOURS

GROSCHOPP

Designed & Manufactured in the USA

Bosch Rexroth

INTRODUCES EFC 3600 VARIABLE FREQUENCY DRIVE

The EFC 3600 variable frequency drive (VFD) by Bosch Rexroth complements the existing product portfolio including the Fe and Fv frequency converters as well as the IndraDrive platform.

The EFC 3600 improves the process control through integrated PID controllers as well as through a sequence control system with eight steps. The settings enable an energy-efficient operation of equipment and machines at their optimal operating point. Due to its overload capacity of up to 200 percent as well as the initial torque of up to 150 percent, the EFC 3600 can be used for a range of applications. The freely scalable V/Hz characteristic allows load-dependent adjustment of the voltage/frequency curve, which ensures a longer motor service life.

The EFC 3600 can be connected to other automation topologies via optional Modbus or Profibus fieldbus interfaces or via digital and analog inputs and outputs. The EFC 3600 is offered covering the performance spectrum from 400W to 4KW (0.5hp to 5hp). Due to the integrated brake chopper and mains filter, additional peripheral devices are not required. The EFC 3600 complies with the EMC directives for industrial applications.

The program structure and easy parameter input provide for quick commissioning and start-up without the need for a PC. Harmonized parameters apply to all converters of the series. With the removable control panel function, the user can configure several electronic frequency converters. This also reduces integration and downtime in case of system expansion or in case of replacement. The service technician would simply use the control panel and copy the existing parameters to the new device.

Due to its design which is complemented by the pluggable I/O terminals and optimized cooling concept, a gapless side-by-side and space-saving installation is possible. For devices up to 0.75 kW (1 hp), cooling fans are not required and subsequently are supplied without fan. Devices with performance level 1.5kW (2 hp) and higher are sup-

plied with integrated fans that can be easily accessed without requiring tools for maintenance. The EFC 3600 complements Rexroth's frequency converter series Fe and Fv, which cover the performance spectrum up to 90 kW (125 hp).

For more information:

Bosch Rexroth
Phone: (847) 645-3600
www.boschrexroth.com/en/xc



R+W
A POPPE + POTTHOFF COMPANY



THE PERFECTIONIST

FOR DYNAMIC PRECISION APPLICATIONS:
OUR METAL BELLOWS COUPLING.

RW-AMERICA.COM

THE COUPLING.



**Established,
Tested,
& Trusted.**



Using technology & innovation to meet your needs – now and into the future.

Brevini Gear:

Offers innovative solutions to complex geartrain challenges with state-of-the-art technologies in engineering, manufacturing and validation.

Focuses only on large, high-precision gears and gear related components.

Commits to meeting your technical, quality and delivery requirements for R&D, quality assurance, serial production or remanufacturing at a competitive price.

The Brevini Advantage

- AGMA Quality Level: 2015-1-A01 Grade 3
- Helical and spur gear capability: 12" (305 mm) to 68.10" (1730 mm)
- Helical and spur ring gear capability: 24" (600 mm) to 94.49" (2400 mm) OD
- In-house deep case, carburizing
- Design, assembly, and gear/gearbox validation

Brevini Gear

2400 N. Priority Way
Yorktown, IN 47396
765-759-2128
info@brevinigeared.com

brevinigeared.com



Browning

EXPANDS SIZE RANGE FOR ENERGY-SAVING TENSO-SET MOTOR BASE

Browning recently introduced an expanded range of sizes at AHR for its self-tensioning Tenso-set motor base. The expanded product range for the energy-saving Tenso-set base will include up to NEMA 447 and equivalent IEC motor frame sizes. At AHR, the Tenso-set base with its quick-release (QR) option – available for NEMA frame sizes up to 286 – will be matched against a standard base of equal size in a belt-change run-off called the Tenso-set Challenge. Product enhancements for the quick-release models will also be highlighted at the show.

“We will have demonstrations at the show on side-by-side identical belt drives with an industry-standard base and another with the Tenso-set quick-release base,” said Browning Director of Marketing Don Sullivan. “We will also be running belt-change speed contests on this setup to give technicians hands-on experience and a chance to see what a life-changer a one-minute belt change can be. We will award interim prizes as well as a grand prize for the fastest belt change performed during the show.

“We added a jam nut on the adjusting rod to hold tension on the spring system before releasing belt tension with the adjusting nut on the rod. The technician simply spins the jam nut forward against the carriage, gives it a turn or two to compress the spring further, and this relieves tension on the adjusting nut so it’s easier to loosen. With the quick-release Tenso-set model, we are able to change belts on a 20-hp motor in about a minute with this improved design – around one-sixth the normal time.”

The Tenso-set base is a drop-in replacement for most standard motor bases, and utilizes the same jackscrew design to adjust and hold tension on



the belt. However, the Tenso-set base includes a coil spring inside the screw housing that pushes against the carriage to maintain tension as the belt naturally breaks-in and seats itself further into the sheave groove due to loss of mass.

“The Tenso-set design helps eliminate the need for frequent belt re-tensioning, including during the first 24 hours of run time, which saves the maintenance staff at least one service call,” said Sullivan. “More important for the building owner, it better maintains the drive’s energy efficiency by preventing the normal tension loss that occurs over time. Some of the largest commercial buildings in the U.S. are already testing this base to determine ROI.”

The QR option for the base allows release of all belt tension after just a few turns of the tensioning screw. The QR base has a patent-pending sliding gate that covers a cutout in the motor frame. This allows the head of the tensioning screw to pass through the base, so the carriage easily slides forward to slacken the belts. After belt installation, the carriage can be moved back and the sliding gate closed to retain the head of the jackscrew for tensioning.

For more information:

Emerson Industrial Automation
Phone: (314) 553-2000
www.emersonindustrial.com

Schneeberger

ANNOUNCES MINISCALE PLUS OPTICAL ENCODER

Schneeberger Linear Technology recently announced the new Miniscale Plus optical encoder system, a miniature guideway with integrated measuring system all in one. Miniscale is based on the Schneeberger Mini-rail guideways. The Miniscale Plus system is available in eight rail widths from 7 mm to 42 mm, and it can be combined with up to four different carriage sizes, and rails up to 1 meter in length.

Maximize system accuracy by taking the measurement at the payload. Compared to an external encoder, the smaller envelope needed for mounting the Miniscale Plus will increase the available real estate inside the machine. In addition, the Miniscale Plus does not require set up or adjustment, saving valuable installation time.

For more information:

Schneeberger, Inc
Phone: (781) 271-0140
www.schneeberger.com

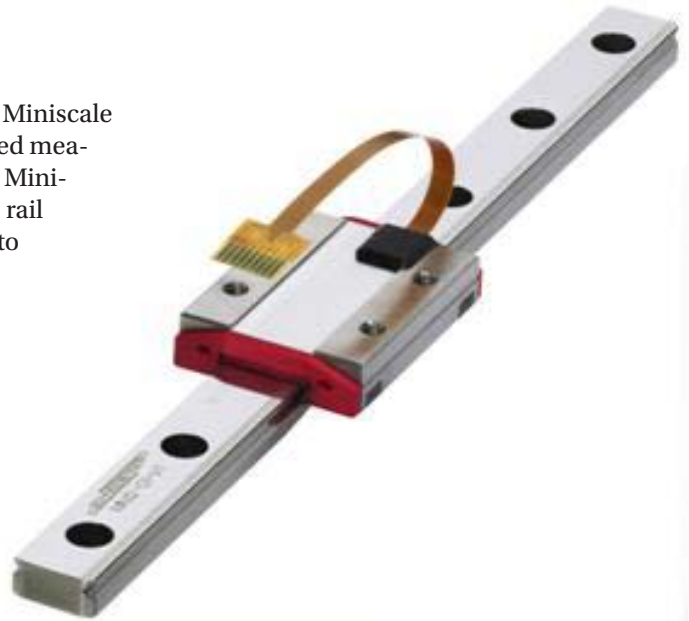
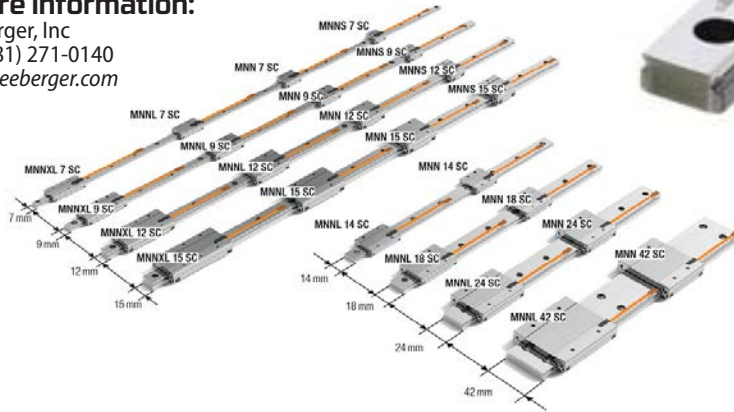

SERVO GEAR REDUCER

Sesame Motor Planetary Gear Reducers

Sesame Motor planetary gear reducers are developed according to one-piece principle to offer precise and reliable operation. It also ensures the concentricity of the transmission components during operation.

- Low backlash
- High levels of reverse rigidity
- High loading capacity
- Optimum sealing, quiet running
- Service life lubricant

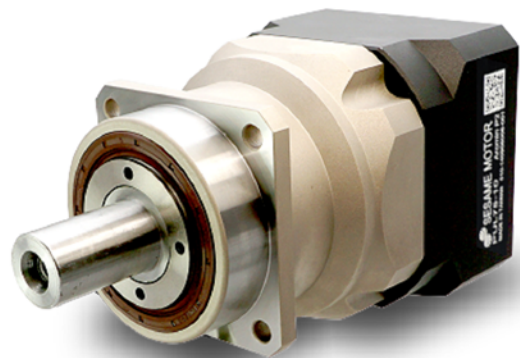

Visit us at
booth G666
Mar. 3-8



Visit us at
H25 A27
Apr. 13-17



MOTOR | GEAR MOTOR | SERVO GEAR REDUCER | ACTUATOR

www.sesamemotor.com



The 5 Golden Rules of Gear Buying

Industry Experts Share Their Tips on Making a Successful Purchase

Erik Schmidt, Assistant Editor

Let's be clear about something up front here: Delta Gear does not make parts for lawnmowers.

This is a fairly flippant point that falls under the timeless, clichéd designation of “goes without saying.” Yet, not all that long ago, Tony Werschky had to say it.

“I’m the person who fields calls from people visiting our website,” said Werschky, Delta’s vice president of sales. “I’ve literally had people calling me asking to replace a gear from a lawnmower. Really just not the targeted customer we’re looking for.”

You think?

Delta (Livonia, MI), a leading supplier of high-precision aerospace gears that makes thousands of transactions a year totaling in the tens of millions of dollars, isn’t exactly in the business of fixing broken down Toro TimeMasters.

Of course, it wasn’t the first time Werschky received a call from someone who wouldn’t know an involute tooth from a tooth ache if hit them straight in the mouth. This buyer, the one living in blissful ignorance of all things gears, exists out there in the world. In fact, there are more of them out there than you’d think. It’s not quite an infestation, but it’s a persistent problem nonetheless.

Werschky’s sage advice: Don’t be that guy.

Here’s how.



Educate Yourself

OK, so maybe that’s a bit too simplistically ambiguous to be of any help to gear-buying newbies, but the general gist is that before conversing with any supplier, you should actually *know what you’re talking about*.

Now, you don’t have to possess an encyclopedic knowledge on the subject dating back to 150 B.C. when the Antikythera mechanism’s bronze gears first churned. No one is expecting you to be Heron of Alexandria.

But some basic working knowledge goes a long way.

“You have to educate yourself about what you need your gears to do,” said Chuck Schultz, owner of engineering consulting firm Beyta Gear Service. “In my book [“Introduction to Gear Design”] I ask basic questions: ‘What kind of gears am I getting? What do they have to be made of? How should they be inspected?’ Those kinds of things.

“For most gear companies, an educated customer is what they want. They don’t want a guy who’s going to be surprised later that there are tool marks here or there.”

Acquiring vast knowledge can take decades, which is how Schultz – a member of the gear industry since 1971 when he worked for The Falk Corporation in Milwaukee, WI – built up his gear mastery to robust levels. His book is a good place to start for those lacking in gear comprehension in desperate need of a quick crash course.

“About 30 years ago I joked that we needed a ‘Gears for Complete Idiots’ book,” Schultz said. “This was long before any of the books were out. I ended up writing one and it’s on my website [www.beytagear.com] for free download.

“I encourage all gear buyers to become as educated as possible on what’s going on in gears. That’s why my book is available.”

For those not willing or able to thumb through Schultz’s gear buying bible, there’s another way to obtain information looking you right in the face. According to Werschky, company executives dealing in the buying of gears should confer with their engineers before delving into any serious negotiations.

“One of the key things a buyer should do is be willing to partner with his engineering staff, because the engineers are going to be able to provide insight as to what kind of quality you’re going to get from a particular supplier,” Werschky said. “Not all suppliers are designed the same way, obviously.

“For [Delta Gear], we’re working with larger OEMs or large assembly companies, so they often have a large staff of buyers who are buying anything from widgets to gears to shafts. There may be a dozen different buyers for the whole project.

“Granted, we may only work with one or two of those buyers, but many times these buyers are untrained. They don’t know the difference between a bearing and a gear. To them it’s just a thing that they have to purchase.

“Some are very educated and were engineers at one point, but others just get promoted from fresh out of college and are very new and green, if you will. That’s why it would be good for them



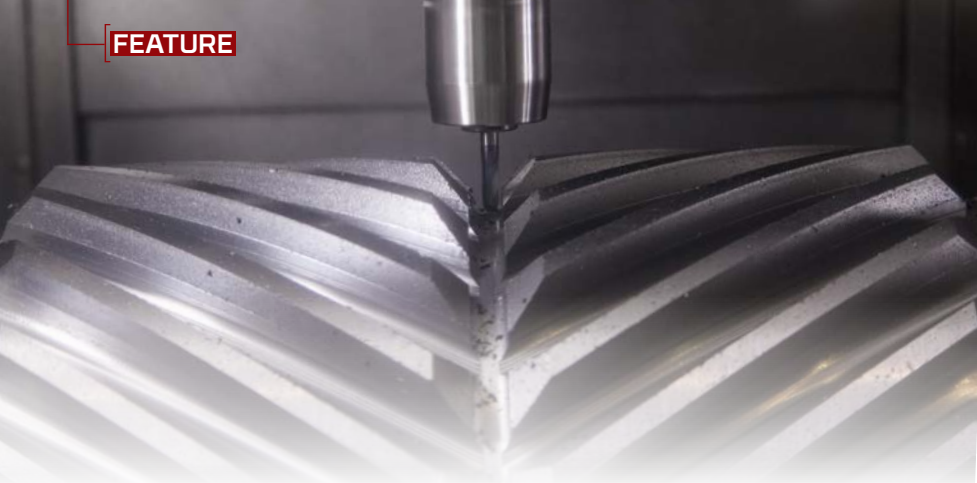

to lean on the knowledge and expertise of other people in their facility to make sure that they're quoting the right companies, as opposed to, 'Hey, I found these three companies on the Internet and their website looks pretty cool.'"



Know Your Supplier

That brings us back to lawnmowers. Remember, Delta doesn't make that kind of gears. Not even close. It would seem impossible to confuse a manufacturer of high-end prototype gears with someone who could help get your Kentucky bluegrass a much needed haircut, but it's happened.

If you search "gear suppliers," there are 29,500,000 results (yeah, the old Google trick isn't a terribly creative way to deliver a point but the effects remain poignant), and out of those nearly 30 million hits only a handful will link you to a company that can provide you with exactly what you need.

As a buyer, you don't have many chances to get it right. There's a million ways to get it wrong.

"There are companies out there who are a wholesaler of parts and they call us out of the blue for a part that we've never made before," Werschky said. "They don't have the drawings for it,

and it's not a part that's our forte, so it's a situation where they probably don't have an engineer on staff, nor have they ever tried to procure the part in the past.

"Maybe it comes down to these companies just needing to get another quote before they buy from someone else, but it happens quite a bit where someone will call us looking for something that we can't really provide, or at least don't usually provide."

As someone who has been on the wrong end of nonsensical inquisitions many times, Werschky said that while there are no *dumb* questions, there are *unnecessary* ones – and it's often better to burden yourself with answering those questions before picking up the phone.

"You need to ask, 'Where is the raw material coming from?'" added Schultz. "Are you doing all the work yourself? Where are you getting the heat treating?"

"That opens up a whole line of questioning to your heat treat vendors, because there are a lot of good heat treaters and there are a lot of guys I wouldn't ask to heat up a shovel. I mean seriously, there are gear heat treaters and others who aren't gear heat treaters – and they don't pretend to be. But if you send it to them they'll put in the furnace and heat it up and cool it down."

The moral of the story is that not all gears are created equally. Manufacturers service a multitude of industries, from aerospace to automotive to mining to oil and gas, and each industry requires precise specifications. Delta, for instance, manufactures custom gears, shafts and gearboxes for the aerospace and automotive industries. Could they make a part for the Dubuque Mining

SEAMLESS ROLLED RINGS • 4" - 144" OD
CARBON • ALLOY • STAINLESS

McINNES
ROLLED RINGS

STILL WAITING ON YOUR DELIVERY?

At McInnes Rolled Rings, we take pride in the high level of speed and service provided to each of our customers, large or small.

When you need it
now, trust McInnes.

ORDERS SHIPPING IN AS FEW AS 5 DAYS!

Why wait...

TYPICAL MARKET LEAD TIMES

6 days	8 days	10 days
12 days	14 days	16 days
18 days	20 days	

www.McInnesRolledRings.com
1.800.569.1420

Company? Sure. Is it what they possess an astute expertise in? Not exactly.

Finding the proper gear supplier may take time, but it's an investment with a continuous payout, because partnering with the perfect manufacturer is essential to achieving smooth, long-lasting success.

Buyers must know their own products, yes. But knowing what the seller's *selling* should never be overlooked.



Draw it Up Right

So you've read "Introduction to Gear Design" a half dozen times and conducted a caffeine-powered search of the World Wide Web until you've located the one gear manufacturer that makes you swoon.

It's time to open that corporate bank account and coat the sky with leafy green rectangles, right?

Whoa, easy there Gordon Gekko. Step away from the ATM machine. Take a deep breath. Let the parameters of the deal swirl around in the old noggin for a while. Then get a pencil and paper.

Before you can run, you have to draw.

"Having clear and concise, understandable drawings is important as well," Werschky said. "We're building to print. Someone sends us a request for a quote (RFQ) along with a drawing, and the drawing has all the information in order to make that part. It

has everything from material to heat treatment to any special coatings. The gear geometry is on there.

"It's important that the information you're providing is as complete as possible so that the supplier can quote it as competitively as they can. When there's lack of information, inside sales people have to be conservative with what they quote in order to protect themselves from the worst case scenario."

For custom gear suppliers, such as Delta, the drawing is everything. Each and every part they make is specially crafted to fit *your machine*. Not his. Not hers. Not that guy over there - *yours*. So make sure your drawing does your machine justice.

Spending the necessary time to create a thorough, detailed drawing can save you weeks or even months down the line.

"Usually [poor drawings] result in delays," Werschky said. "What happens is we quote a job and if the job is released to us and we start to make it, we go through an engineering stage where we're processing the job to go out on the floor. At that point, if there's missing information we have to go back and contact the customer, they have to get the information to the right person, that person has to provide the information that we need - sometimes, in larger companies, that will take weeks.

"Everybody is in a hurry. They all want parts fast. I don't know anyone who will say, 'No, take your time. I can wait.' They all want parts as fast as they can get them.

"Not having the right information when you initialize an RFQ is going to slow down the process, and that's only going to slow down your ability to get to market with your finished product."

And it's not just time you're going to save by producing pristine drawings - it's money, energy and ever-important peace of mind.

"I have a client who routinely sends people drawings that aren't legible," Schultz said. "Then he's unhappy because the gear shop has to ask a lot of questions.

"[If you don't have good drawings] you're going to get parts that don't fit or don't work. You're going to have delays. If you have tooling that goes with the job, you have to make sure you explain that to them or you're going to pay for tooling twice. If you have spline gauges or bore gauges, you have to identify that.

"Make sure your drawings are readable and understandable for everyone."



Get the Proper Papers

This one seems pretty simple, but somehow it's a step that some buyers gloss over, according to Werschky.

"You want to make sure you're getting the documented proof of what the quality is you're looking for," he said. "Meaning, you want inspection reports with what you're getting.

"It may sound like a no-brainer, but unless you spell it out, some companies won't provide that information to you. While other companies, like [Delta], always provide it because we're ISO certified and AS9100 certified. It's part of our standard operation procedure to provide those inspection reports.

POWERFUL CONNECTIONS

OCTOBER 20-22, 2015
DETROIT, MI
COBO CENTER

SAVE THE DATE

FOR **THE DRIVE TECHNOLOGY SHOW** OF THE YEAR!

GEAR EXPO 2015 brings together the full range of experts — design, manufacturing, application engineering — all in the same place — **Cobo Center, Detroit, October 20-22.**

From a single gear to complex drives, **GEAR EXPO** covers it all...

- **More exhibitors** — from gear making machines to systems integrators.
- **More education sessions** — from metallurgy and geometry to maximizing power density.
- **More attendees** — buyers and makers from automotive, construction, mining, agriculture — wherever high-performance drives are critical.
- **More solutions** — meet the experts and evaluate your capabilities.

GEAR EXPO 2015 is the place to be.

- Make powerful connections.
- See the latest technology in action.
- Get the inspiration you need to take your products to the next level.

Improved drive technology is critical to achieving higher efficiencies and longer service life. All the information and answers you need will be at **GEAR EXPO 2015.**



Registration opens in spring 2015 at www.gearexpo.com



Fight the Lure of the Cheapskate

"It's something that costs money to provide, so it's included in our price. That makes us less competitive against someone who doesn't really inspect parts. But it's crucial [the buyer] gets documented proof and they spell that out in their RFQ."

If things go awry for unbeknownst reasons (maybe your drawings weren't up to snuff, *cough, cough*), it becomes nearly impossible to prove it was the supplier's fault – and get reimbursed those precious greenbacks – without the proper paperwork.

"[Without paperwork] the buyer has no way of proving that the gear was produced correctly," Werschky said. "That leads to noise problems, failures in the field, all kinds of problems they don't want to have. Sometimes it's hard to point the finger after the fact. The cost of quality is so much more expensive when there's a failure in the field as opposed to catching it before the parts are even shipped."

And remember one of gear buying's golden rules: Ask and you shall receive.

"You want a certificate of compliance, but if you need more than that you have to say that and you have to expect that you're going to get charged for it because there is time involved," added Schultz.

"If you don't get the documentation, you're going to end up with a [confrontation] later on why the gears are noisy or why they didn't work. I have some information about chart reading in my book. You can have gears that have really good looking charts but still don't perform well, simply because the design isn't right.

"If you expect to get something, you better ask for it."

As a species, humanity has an abundance of strong natural responses, one of the most prominent of which is the irresistible tug that pulls us from common sense and leads us straight to the lowest bidder.

Just call it the Lure of the Cheapskate.

Now, there's nothing wrong with being frugal. Saving money is certainly a dignified and respectable course of action, but being irrationally cheap at the forefront of negotiations is usually just a harbinger of an excessive money sink looming in the future.

And if "ask and you shall receive" is the golden rule of gear buying, then "you get what you pay for" is probably the platinum one.

"The cost of quality is so much more expensive if you have a problem," Werschky said, "and [problems arise] when you have lack of information, or when you have someone who is trying to produce a part of a certain quality without really having the right equipment to produce that quality. For example, they're trying to cut a gear and heat treat it and have it be finished, when really it needs to be hard finished after heat treatment.

"When there's a problem the cost associated with backtracking and replacing it is so much more – it's 10 times more expensive, I would say – than just spending a little more at the time of procurement to have that knowledge and peace of mind that the part is to the print."

How do you avoid the Lure?

Well, first of all, go ahead and tie yourself tight to the mast of a schooner. You can thank Odysseus for that one. Second – and much more importantly – get multiple quotes.

Be patient.

Weigh the pros and cons of each offer.

Remember that more money up front isn't wasted change but a smart and sound investment for years down the line.

"There's more to buying a gear than just getting a low price," said Schultz. "I encourage people to visit their vendors. I wouldn't place an important order without visiting people.

"People lose their jobs all the time for vendors not providing the right stuff. Don't be one of them."

Then, when all the factors have been accounted for, untie yourself from that infernal mast and sign on the dotted line.

Congratulations.

You just bought some gears. **PTE**

For more information:

Delta Gear, Inc.
Phone: (734) 525-8000
www.delta-gear.com

Beyta Gear Service
Phone: (630) 209-1652
www.beytagear.com

For Related Articles Search

purchasing

at www.powertransmission.com

YOUR MECHANICAL ADVANTAGE



Every detail matters. Consistency, precision and quality are key. Fortunately for you, that's where First Gear excels.

Not just the ability to innovate. The ability to ensure each step is done correctly. Prototyping, hobbing, skiving, grinding, shaping, finish rolling, contract inspection, hob sharpening and more, we do it all.

And better yet. We do it all extremely well.

First Gear. YOUR MECHANICAL ADVANTAGE

FIRST GEAR

ENGINEERING & TECHNOLOGY

www.first-gear.com

7606 Freedom Way
Fort Wayne, Indiana 46818
Tel: (260) 490-3238

Innovative Design Solves Automotive Parts Assembly Challenge

Weiss North America, Inc. of Willoughby, OH has designed and produced rotary tables and other components for the automation industry for more than 45 years. When approached by Alpha Integration, Inc. of Murfreesboro, TN, a manufacturer of turnkey automated assembly, vision and testing systems, to provide a reliable turnkey solution for their 6-foot-tall automotive parts assembly machine, Weiss ‘tiered-up’ an innovative chassis and indexing table system solution.

In the process of laying out the plan of the machine, Alpha’s senior mechanical design engineer, Sam Westbrooks, knew he wanted an open-center indexer to mount the tooling towards the inside of the dial system on a stationary center plate. This design configuration would accommodate ease-of-loading for its 12 load stations, as well as pro-



This automated assembly machine produced by Alpha Integration, required an innovative design and custom approach from supplier Weiss North America.

viding clear viewing of the processes and easier maintenance.

Additionally, to facilitate the tooling, the indexer would have to be 5 feet off the ground, which would require the base frame/chassis to be uniquely structured.

Tiered-Up/Open-Center Technology:

The key to the Weiss solution involved the stationary center plate, dial plate, and base frames. These were all manufactured and machined complete by Weiss at their Willoughby, OH facility and delivered to the client as a one-source, preassembled system. This allowed Alpha to build the nest and station assemblies offline so that they could be integrated to the dial system with ease.

At the core of the fully integrated system was the Weiss TR1500 rotary index table ring with a large open center—which offered an extremely low profile design with a high level of accuracy. The TR1500 ring allowed for optimal design space in a robust mechanical design. This also reduced the overall footprint of the machine with improved accuracy and access to parts.

Even with Alpha’s machine featuring 12 clip install stations, it proved no problem for the Weiss TR1500 series, which offers ring diameters of up to 2,200 mm — providing more than enough scope for coupling with processing stations.

The height limitations of the chassis design were overcome by utilizing one base frame that leveraged two other riser frames to make up the rest of the height. The first riser attached to the top of the base frame and supported the TR1500 index table that featured a 90.5" diameter tool plate. The second riser frame was used to support the electroless-nickel plated steel stationary plate. Ultimately, the frame/riser system design was able to lift the index table up to the specified height require-

ments, with the final system structure resembling a ‘three-tiered cake’.

The majority of the machine’s 12 stations required a press station to be bolted on top of the 1" thick steel stationary plate. These press assembly stations apply down forces onto the nests that are carried by the index table’s aluminum tool plate. To overcome potentially debilitating force of approximately 900 lbs. acting on the 410 lb. center stationary plate and index table, Weiss’ design leveraged an intermediate riser weldment going through the indexer and bolting to the middle riser frame which by-passed the indexer totally—creating a ‘no-forces’ solution onto the index table that promotes longevity.



Because there is no tooling in the way, the dial system is wide open for ease of loading and allows for an easier view of the entire production process.

For Related Articles Search

rotary tables

at www.powertransmission.com

All of the Weiss system's tables and rings offered accurate dowel holes on all mounting surfaces including the main casting for mounting to the machine base, the rotating dial plate for easy mounting of the tool plate, and on the center stationary plate. Alpha simply transferred Weiss' mounting hole pattern to their tool plate drawing, requiring no adjustment or reaming of dowel holes at assembly.

With the Weiss dial system design at the center of the assembly, Alpha was able to keep all of the tooling and mounting originating from the interior of the dial assembly—allowing servicing of the system to be much easier. Additionally, because there is no tool-

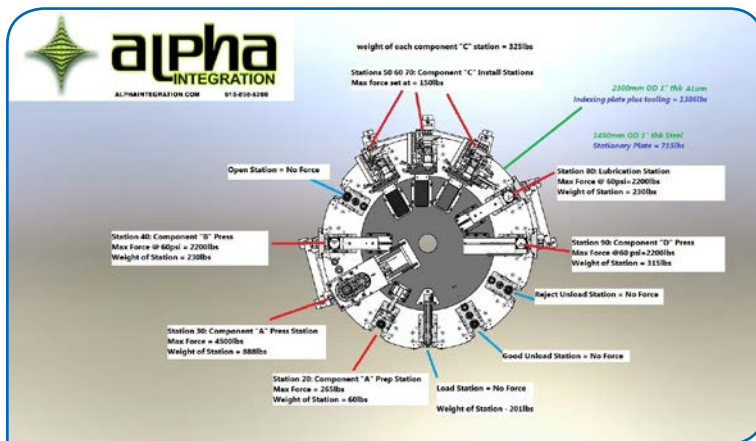

The system accommodates a wide variety of weights and loads while maintaining accuracy and long life.



www.circlegear.com

Circle Gear and Machine

1501 South 55th Ct. • Cicero, IL 60804
Ph: 708-652-1000 • Fax: 708-652-1100

WE'RE EXPANDING!



EQUIPMENT PURCHASES

- Luren LFG-8040 Verticle Gear Profile Grinder
- Gleason 463 spiral/hypoid gear tooth grinder

FACILITY

- Purchased 77,000 sq ft building, expanding to 122,000 sq ft

STRATEGIC PLANS

- Continued growth in spiral bevel/hypoid marketplace
- Expand gearbox service and overhaul business

GEARBOX REPAIR SPECIALISTS

- Prompt, accurate quotations
- Competitive pricing
- Quality repairs/rebuilds

Quality Reducer Service

1501 South 55th Ct. ■ Cicero, IL 60804
708-354-8080 | FAX: 708-652-1133



WE SERVICE ALL TYPES OF INDUSTRIAL GEARBOXES

www.qualityreducer.com

ing in the way, the dial system is wide open for ease of loading and allows for an easier view of the entire production process.

Even if Alpha had utilized a typical dial system design with a stationary center plate, the loads on the stationary center plates would have been extremely overhung and unstable—un-

like what was achieved with the Weiss dial system.

Conclusion

The combination of robust construction and innovative, ‘open-center’ design allowed the Weiss engineering group to provide Alpha with a superior, one-source automotive parts assembly



To accommodate the downward forces generated by the assembly machine’s press stations, the Weiss design uses an intermediate riser weldment going through the indexer and bolting to the middle riser frame.

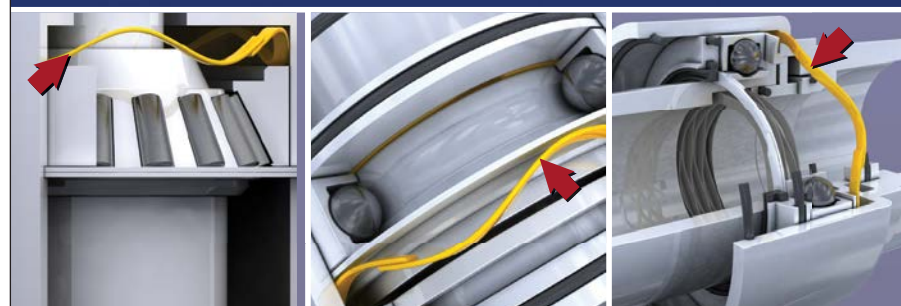

ELIMINATE **NOISY BEARINGS** ELIMINATE

Smalley Springs Extend Bearing Life

- Reduce vibration, noise and heat buildup
- Compensate for dimensional variation within assemblies
- Stock sizes 16 mm to 580 mm, matching popular bearing sizes
- Specials from .200" to 120" with No-Tooling-Charges™

www.smalley.com



Smalley
Steel Ring Company

www.smalley.com/getcatalog • info@smalley.com
Lake Zurich, IL • 847.719.5900 • Fax: 847.719.5999

solution—delivering a 26 second cycle time with an indexing speed of 2.3 seconds.

Finally, to facilitate the collaborative assembly design effort, Weiss’s engineers also used the same CAD/3D software (*Solidworks*) platform as Alpha Integration. According to Westbrook, “It was immensely convenient to send CAD files to and from Weiss to seamlessly share designs. It was like a breath of fresh air to work with a company that ‘spoke our language’ when it came to CAD/3D and design.”

Westbrook concluded, “By using Weiss for the complete system package, we don’t have to worry about getting plates or base frames made and finished. The system comes complete so the tooling can be installed immediately, which is efficient and convenient. Plus, the delivery times from Weiss were outstanding.”

Currently, three more of the same system configuration solutions are being manufactured and assembled by Weiss for Alpha Integration, Inc. **PTE**

For more information:

Weiss North America Inc.
3860 Ben Hur Avenue
Willoughby, OH 44094
(888) 934-7762
www.weissna.com
info@weissna.com

Gear Up for Reduced Downtime



BALDOR • DODGE

Baldor • Dodge® gear reducers bring a level of quality and reliability to your machines that give you one less thing to worry about. For OEM designs or in-the-field replacement, there's a Baldor • Dodge gear reducer perfect for your application, close by and ready to get to work.

Reduce your downtime stress a notch or two by choosing from the family of gear reducers that tackle the toughest challenges industry can throw at them...day after day after day.

baldor.com 479-646-4711

- Unmatched Quality
- Superior Reliability
- Energy Efficient

BALDOR
A MEMBER OF THE ABB GROUP

A Quasar Ride to Automate 2015

Bill Walton and robots – what more do you need?

Erik Schmidt, Assistant Editor

Bill Walton – a 7 foot tall anomaly from the annals of basketball history who wears tie-dye shirts, listens to the Grateful Dead and, according to his own outlandish proclamations, hasn't taken an indoor shower in 35 years – is well-known for looking at average accomplishments and being overcome with extreme fits of emotion.

Over the course of his long, strange journey as a broadcaster, the peculiar former Portland Trail Blazers star has drawn comparisons between NBA players and the Age of Romanticism, Sir Isaac Newton and Beethoven's Symphony No. 3 in E-flat.

As you may have gathered, hyperbole is Walton's native tongue. In the world of professional sports, it falls on deaf ears, mostly.

Now, Walton, odd as it may seem, will be a special guest during the Automate 2015 show that takes place from March 23-26 at McCormick Place in Chicago, IL.

Sure, at face value this pairing is about as logical as one of Walton's infamous sound bites ("Vladimir Radmanovic, this guy is cut from stone! It's as if Michelangelo were reading and a lightning bolt flashed before him!").

But here's where it starts to make some sense:

Surrounded by groundbreaking technology and innovative, world-leading visioneers, amidst 75,000 square feet of robotic and automation glory that will literally help shape the world of tomorrow and the decades that follow, Walton's rampant poetic musings finally won't feel so out of place.

So join Walton, hitch a ride on a quasar and take it all the way to the top of the mountain to the Promised Land.

This is Automate 2015.



Guests look at a display during Automate 2013.

The Show

One oversized Deadhead with a mean midrange jumper and a penchant for referencing the legends of antiquity?

Check.

But what else can attendees expect at Automate 2015? Everything and the (automated) kitchen sink.

"We consider [Automate] the broadest automation solution show in North America," said Bob Doyle, director of communications for the Association for Advancing Automation. "We have robots, machine vision technologies, motion control, and a whole integrator section at the front of the show with a bunch of exhibitors showing off a whole bunch of innovative solutions."

The show now known as Automate began in 1977 when it was called the International Robots, Vision & Motion Control Show, which was a smaller, quaint version of the massive biennial robot-palooza that has hit the Windy City every two years since 2011.

"It's definitely broader now and much larger," Doyle said.

Much larger – yeah, in the same way that the Kraken is *much larger* than the breaded calamari rings at an Italian restaurant.

The show, according to Doyle, is going to be about 50 percent bigger in

both size and scope than the comparatively puny 2013 version. He's expecting roughly 300 exhibitors and 15,000 attendees.

"We're geared towards many, many different industries, but any manufacturer who is looking for a way to better their product through use of automation in some way will find a solution at our show," Doyle said.

Really, that's what Automate's purpose is at a subatomic level: solving problems. The show in and of itself is an entertaining circus of cutting-edge automated technology and an absolute utopia for small business owners and giant corporations alike. And while there will undoubtedly be many fun things to view on the show floor – a robot that puts together puzzles with pinpoint accuracy, anyone? – the real purpose of Automate is not to dazzle, but to *progress*.

Accompanying the show is a comprehensive educational conference featuring a broad array of classes from beginner to advanced skill levels. Classes are taught by experienced industry professionals who understand the challenges attendees face, according to Doyle.

"The show is free while the conference obviously has a cost," he said. "But

if anyone wants to learn more about robotics, vision or motion control, we have a whole conference that you can register for, either day by day or the whole week. If you go to our website (www.automateshow.com) you can see the full lineup and conference agenda.

"Also, as a part of that, we're hosting the International Symposium on Robotics, which is an international event that hasn't been in the United States in several years. That will be pretty cool.

"One other thing of note on the show floor is what we call 'expert huddles.' This is an opportunity for attendees to talk with an expert in the field about a topic in a smaller setting of 10 or 12 people. It's not a PowerPoint presentation or anything like that - it's actually a conversation about solutions that are provided in the automation space."

Keynote speakers for the three-day show will be Rene Noemi (March 23), the director of Android and Chrome Global Business, John Mackey (March 24), cofounder and CEO of Whole Foods Market, and, perhaps most no-

tably, Steve Wozniak (March 25), cofounder of Apple.

Then, of course, there's Walton, who will be in attendance on March 24 for the Automate Madness Networking Party.

"We're calling it Automate Madness because the March Madness NCAA Tournament is around the same time," Doyle said. "After 5 p.m. we're having a basketball-themed event with food and drinks and [Walton] will be making his appearance."

Add it all up.

As Walton would surely say: Automate is primed to be the best show in the history of Western civilization.

The Robots

In all seriousness, though, that's quite enough about Walton. Though he figures to be one of the more popular attractions during the course of the week (and the tallest), the show isn't about him.

It's about the robots.

"For us, Automate is a robotic specific tradeshow, really," said Alex Miller,

ABB Robotics sales manager. "I know there are other aspects of automation that are there, but it's put on in conjunction with the Robotic Industries Association. It is probably the only robotic specific tradeshow we go to.

"We will show a wider range of our robotic technology at Automate than we would at any other show."

Attendees can expect to see the full spectrum of robotic and automation technology on display at Automate: big and small, complicated and simple, dangerous and friendly, blue, yellow, white and orange.

And out of all the hundreds of robots expected to be featured at the show, there may be one type in particular that stands out head and shoulders - err, nuts and bolts - above the rest.

"Collaborative robots are a very hot topic right now in the industry," Doyle said. "Basically, a collaborative robot is a robot that can work side-by-side with people. When you think of a traditional robot it's behind a cage. A collaborative robot is unique in that it's safer to work right next to and is much more nimble.



**YOU THINK YOU'RE SO TOUGH?
MEET MY BROTHER.**

One of the most rugged, reliable gearmotors available today.

- High-grade grease standard helps to eliminate costly downtime
- Sealed for life - no refilling and level checks required
- Electrostat paint process delivers tough, chemically-resistant coating for the harshest operating environments
- 16 standard ratio options / 6 voltage options
- Experience and expertise - 10 million units produced in primary gearmotors facility over its 40 year history

Designed for reliability. Built for endurance.

brother
at your side

866.523.6283

BrotherGearmotors.com

"I know several exhibitors will be there with their collaborative robots and suppliers will be introducing some new products, which I think is going to be pretty exciting."

ABB (Auburn Hills, MI), one of the world's leading suppliers of industrial robots and modular manufacturing systems, will not be showcasing any collaborative robots at Automate, but they do have several exciting things planned for the eight robots they're bringing, according to Miller.

"There's kind of a theme to what we're bringing," he said. "That theme is centered on how robots are becoming more efficient. Robots are lighter, they take up less space, they're easier to operate - that efficiency is essential."

The newest model that ABB will have on display is the IRB 1200, a compact, flexible, fast and functional small industrial robot that was released in the fall of 2014.

"It's ideal for assembly and material handling, etcetera," Miller said. "That's on the small end. On the larger end we have the IRB 6700, and then we have

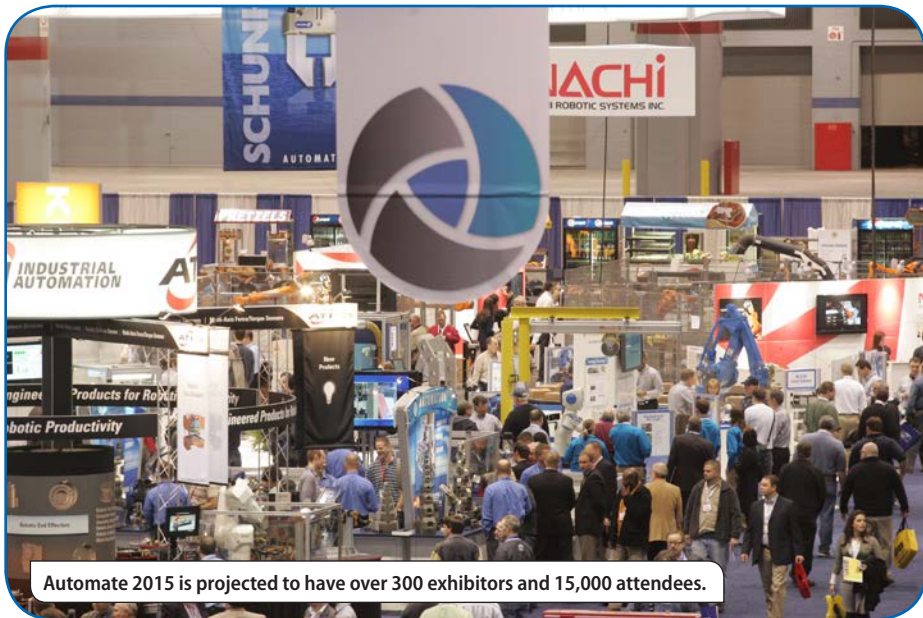

some other demos as well. We have our IRB 360 FlexPicker and we have another small robot at 120."

Arguably the most fascinating presentation for ABB will be its FlexPicker, a high speed picking and packing robot with a reach of 1,600 mm and a mid-range payload of up to 6 kg. The

FlexPicker's most famous application - one that dessert aficionados will be most disappointed to find is not going to be on display at Automate - is putting the tops on Pepperidge Farm Milano cookies.

"We're going to be showing some high speed picking and placing," Miller



EXCEL GEAR, INC.

GEARS 1"-60" - AGMA 15

The **EXCEL** promise;
We'll excel where others fall short.

- Complete gear design, manufacturing and reverse engineering services
- Gear hobbing & grinding from 1"-60" (To AGMA 15)
- Internal gear grinding from 10"- 60"
- Gear shaping to 36" diameter (9" face width)
- Wind turbine gear boxes, high speed spindles, gimbal heads and gear boxes
- Competitive prices and quality gear design and manufacturing with delivery commitments you can count on!

A TOTAL SERVICE COMPANY
ISO9001-2008 APPROVED

Introducing Excel-Lent Gear Design Software
providing accurate gear design and analysis that can get anyone up and running fast - www.excel-lentsoftware.com

815-623-3414

quotations@ExcelGear.com

www.ExcelGear.com

YOU Count on, Brands People You Trust

Rexnord's newest gear drive, the Falk V-Class™, is engineered to deliver power, durability and reliability under the toughest conditions. Its unprecedented design and test procedures mean longer seal life, improved thermal performance and increased operating life. The Falk V-Class gear drive provides shorter lead times, convenient serviceability and faster, easy access support.



And, you can find the **Rexnord** Falk V-Class at your local **Motion Industries** location. Our local sales and service specialists are experts in application and technical support, providing the parts and the know-how you need to stay up and running.



Scan this code with your smartphone for more information.

<http://esp.to/w7TY0I>

The brands you count on from the people you trust...that's Rexnord and Motion Industries.



Call. 800-526-9328
Click. www.motionindustries.com
Visit. Over 550 Locations



Over 550 locations | More than 5.6 million products | Industrial maintenance training courses

©2015 Motion Industries, Inc.

said. "It's not going to be Milano cookies - I'm not actually sure what the little product will be - but they'll be randomly displaced on the conveyor and the robot, with its vision, will be able to pick it and place it on a conveyor very quickly."

Yaskawa Motoman, a robotic automation supplier out of West Carrollton, OH that began its involvement with Automate back in 1989 under its previous name and direction, will have one of the largest booths at the show.

"In 2015 Yaskawa Electric Corporation will be celebrating their 100th anniversary," said Tim DeRosett, director of strategic initiatives at Yaskawa Motoman. "We will be featuring a range of robots, controls and motion products. We will also have some very exciting demonstrations focusing on healthcare."

"While there are certainly larger shows that focus on specific vertical markets, Automate crosses all segments with solutions that help companies solve their production needs. There is a lot of energy around production robots for general industry."

"It's a great time to be in automation."

The Exhibitors

While attendees' eyes will be focused on the robots - and really, who can blame them? - the eyes of the exhibitors at Automate will be looking at each other.

"The most unique aspect of it, compared to other trade shows we go to, is that Automate is all automation companies next to each other," Miller said. "We'll see competitors right across the aisle from us. When we go to other trade shows, our competitors are dispersed all throughout the hall."

"One of the most distinguishing features is that you can see all your competitors in one place and they're all within 50 yards of you."

With the number of exhibitors at 267 less than two months away from the show, the grand total could potentially reach in excess of 300, according to Doyle.

Three hundred companies, some robotic and automation suppliers like ABB and Yaskawa and Fanuc, others eager buyers like Atlanta Drive Systems, Inc., Boca Bearing Company,

Diequa Corporation, Harmonic Drive LLC and Iigus Inc., all within a six-axis robot's reach.

It's the very definition of "keep your friends close, but keep your enemies closer."

And it's what makes Automate such a distinct event.

"Everything is *right there* in the robotic industry, Miller said. "You can see what every robot manufacturer has to offer. And that is invaluable."

Bill Walton couldn't have said it better himself. **PTE**

For more information:

Association for Advancing Automation
Phone: (734) 994-6088
www.a3automate.org

ABB Automation
Phone: (800) 420-0707
www.abb.com

Yaskawa Motoman Robotics
Phone: (937) 847-6200
www.motoman.com



Precision Gear Technology - Made in Germany!
Customized gear engineering & drive solutions for numerous applications.

FramoMorat
Franz Morat Group

www.framo-morat.com

Your Idea - Our Drive

Whether metal or plastics - we are your reliable partner for customized gear & drive solutions for Automotive, Gearbox Technology, Green Technology or Material Handling.

Custom drive solutions

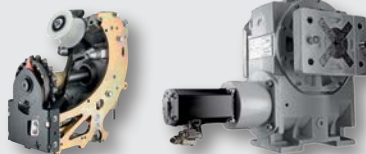

Standard drive solutions



Gear Technology & Worm Gear Sets



Custom plastic solutions



Local support in New Mexico, USA

usa@framo-morat.com
call #800-956-6728

We look forward to hearing from you soon!



THOTH

Quality Achievement Dream

Ningbo Zhongyi Hydraulic Motor Co, Ltd was found in 1971, which is the high tech mfg. expert of orbital motors, steering control units, transmission and mobile motors. At present we have two manufacturing bases, one is in Ningbo city covering an area of 44,000 square meters, the other one is in Wuhu city with an area of 80,000 square meters. Our manufacturing workshop meets the international standards and the manufacture and test equipments are leading technologically home and abroad. The staffs of Zhongyi will creat first class products, services and brand hands in hands with you.

For more information, pls visit www.zihyd.com.

Email: sales@zihyd.com Linda@zihyd.com

Tel: 0086-574-86378895 Fax: 0086-574-86378310



Gear Rating

THE QUESTION

In order to realize meaningful savings using low-cost gear motors, some gear motor manufacturers are sizing the gears with safety for stress at single tooth contact S_H min below 1.00; i.e. — minimal S_H 0.82 — according to Calculation Method DIN 3990; Method B. Is this possible? Will the gear life be limited?

Expert response provided by Frank C. Uherek, principal engineer, Rexnord Gear

Rating methods have safety factors based on flank (pitting) labeled as S_H and root (bending) labeled as S_F . They are computed as the ratio of the modified allowable stress number to the actual stress number. These values are a function of tooth geometry, method of manufacture, material, heat treatment, and application. If we assume an application factor K_A of 1.0 based on the use of the product, a safety factor of 1.0 is based on 5×10^7 load cycles when pitting is not permitted. A value of S_H less than 1.0 may be based on using some of the de-rate in power

capacity caused by an application factor greater than 1.0 in the actual stress number calculation. Loading, application factor, number of load cycles, and minimum safety factors are subject to client/vendor agreement — as noted in the standard — and should be carefully reviewed to ensure the expected performance of the gear drive in the specific application.

A detailed review of the application and all factors used in the rating analysis would be required to determine the origin of the safety factor being less than 1.0 in this case.

Frank C. Uherek is

principal engineer/mill products for Rexnord Geared Products in Milwaukee WI. In over 30 years he has held various positions in design engineering and quality management, including enclosed drives, wind turbine drives, and open gearing for mill and kiln applications. He has served on numerous AGMA technical committees, including as vice chairman (and editor) of the Helical Gear Rating Committee, and received the AGMA TDEC award in 1997. In 2011, Uherek received the AGMA Distinguished Service Award for his work in developing AGMA gear rating standards.



*A Great Gear Company
Doesn't Form Overnight.*

Your Trusted Source For...

720 Months
3,120 Weeks
21,900 Days
525,000 Hours
31,536,000 Seconds



*Celebrating Our
Diamond Jubilee...
We're Just Getting Started.*

FOREST CITY GEAR

11715 Main Street, Roscoe, IL 61073 | 815-623-2168
forestcitygear.com

Gear Wear Calculation and Prediction

Dr. Ing. Ulrich Kissling and MSc. Ing. Sandro Hauri

Wear is a very important topic for dry running plastic gears. Over the past few years, the authors have worked closely with a number of manufacturers of plastic gears to investigate the problems of gear wear in detail. Together they have developed a calculation method that can be used to predict where and when local wear will occur on a tooth flank. Their findings have also just been published in the final version of VDI 2736.

Theory of Wear and Wear Coefficient

The term “wear” is used to describe the progressive removal of surface material due to mechanical and/or chemical stress. The four main wear processes defined in DIN 50320 are adhesion, abrasion, surface break-up and tribo-chemical reaction.

The simplest method of measuring wear is to press a pin made of the material being investigated against a rotating ring (Figure 1). In the plastics industry, this method is known as the “pin and disk test rig” test. When investigating plastics, this ring is usually made of metal with a low surface roughness R_z .

The wear coefficient k_w derived using the pin and disk test rig (Figure 2) – is defined as follows:

$$W = k_w \cdot p \cdot v \cdot t \quad (1)$$

The wear formula (Eq. 1) can be modified for use in the tooth flank:

Wear removal	W	mm
Surface pressure	p	N/mm ²
Sliding velocity (pin and disk test rig)	v	m/s
Time	t	s
Wear coefficient	k_w	mm ³ /Nm*1e-6
Tooth normal force	F_n	N
Supporting width	b	mm
Sliding velocity (tooth flank)	v_g	m/s
Speed in direction of tangent	v_p	m/s
Specific sliding	ζ	-
Number of load cycles	N	-

$$W_{\text{lokal}} = \frac{F_{n,\text{lokal}}}{b} \cdot N \cdot \zeta \cdot k_w \quad (2)$$

This determines the local wear in each point of the tooth contact area on the gear. At the suggestion of the authors, this formula has been included

in VDI 2736 (Ref. 1). Another confirmation of the formula’s effectiveness is that Feulner (Ref. 2) derived the same formula on the basis of measurements.

Determining the Progression of Wear

The wear characteristics can be calculated by implementing the formula (Eq. 2) for local wear on the flank in a gear contact analysis. This makes it possible to define the shape of the abraded tooth flank. Initially, this approach did not provide any usable results, if the wear — starting with a perfect tooth form — was determined in a single calculation step. The wear characteristics must be calculated step by step because the tooth form changes as it becomes worn, and therefore the load distribution moves across the meshing. Very useful results can now be achieved by running the calculation at a sufficient number of small increments. The maxi-

mum permitted wear per iterative step must be predefined, so that the iterative progression of wear can be calculated. This predefined value is critical for achieving realistic results. This recently developed calculation method has been used to compare a range of gears that have been subjected to testing and then measured in 3D.

Figure 3 shows this type of comparison using a pairing where the plastic (PBT) output gear is badly worn. The difference between the arithmetical forecasts, with and without iterative

calculation, clearly shows that the wear characteristics along the flank without iteration cannot be used and it displays quite a different trend to the measured progression. A maximum interval of 1 μm wear per iterative step has been defined for the wear characteristics in a forecast with iteration. In this case, 146 iterations were calculated (the calculation took 2.5 min, using an Intel Core i7-3770). The result showed a relatively good match with the measurement.

Influence on Transmission Error

As the tooth form can now be predicted with reasonable accuracy, more detailed analyses — for example, determining the change in load distribution or the increase in transmission error due to wear — can be defined. Increasing vibrations in the meshing over a long period of time can reduce the endurance limit. This is a recognized effect of frosting and a cause of concern wherever gears are used. For this reason, being able to predict the progression of transmission error in advance is a very interesting result.

Initial verifications performed on different pairs of gears have revealed that transmission error has a tendency to decrease in the first phase of wear (“running-in phase”); however, as the amount of wear increases, this error also increases significantly to reach values that are two to three times greater.

Figure 4 shows results calculated using a steel/PBT gear pair (Figure 3). When the tooth flank calculated by wear iterations is verified with contact analysis, it is visible that the “Peak-to-Peak Transmission Error” (PPTE) is much greater when the wear has also

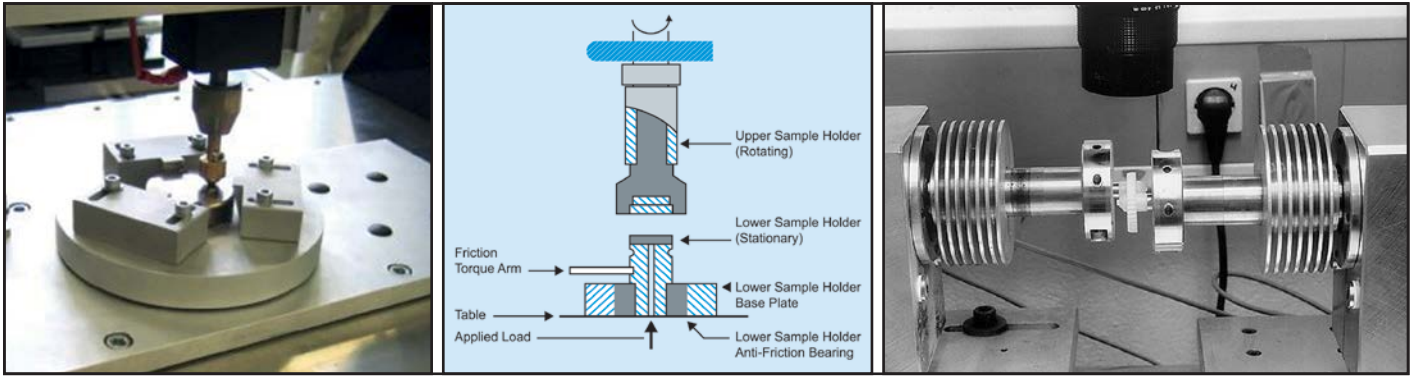

Figure 1 Left: pin and disk test rig. Middle: "thrust washer" test rig. Right: gear testing apparatus.

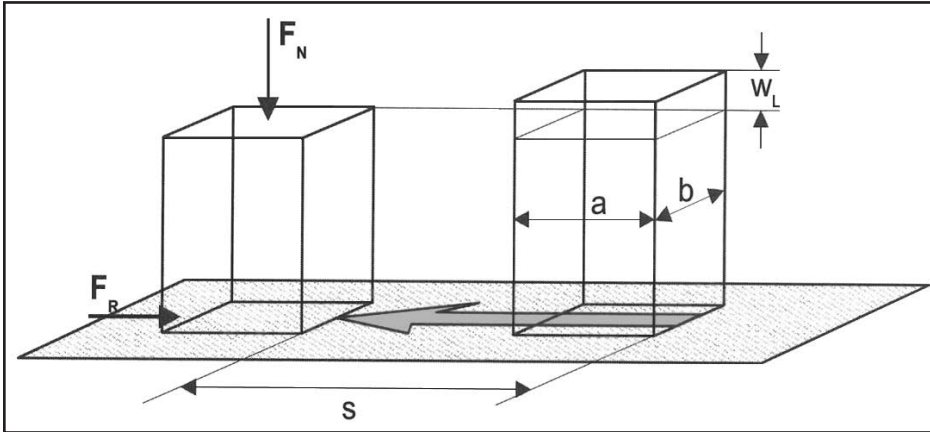

Figure 2 Diagram showing how wear rates are determined (pin and disk test).

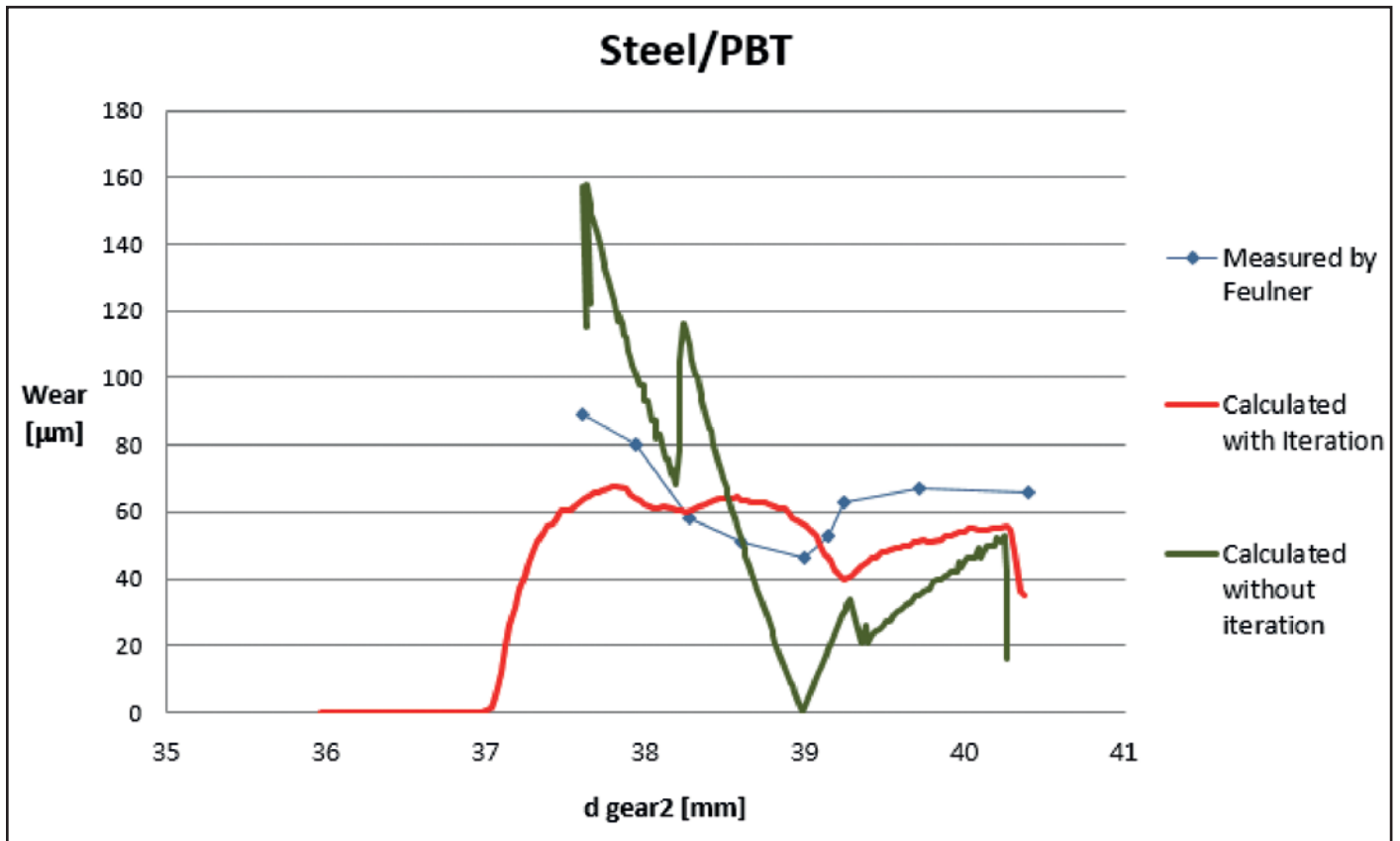

Figure 3 Wear characteristics on a dry-running PBT gear, in accordance with measurement (Ref. 2) and in accordance with the calculation with and without an iterative definition of the progression of wear.

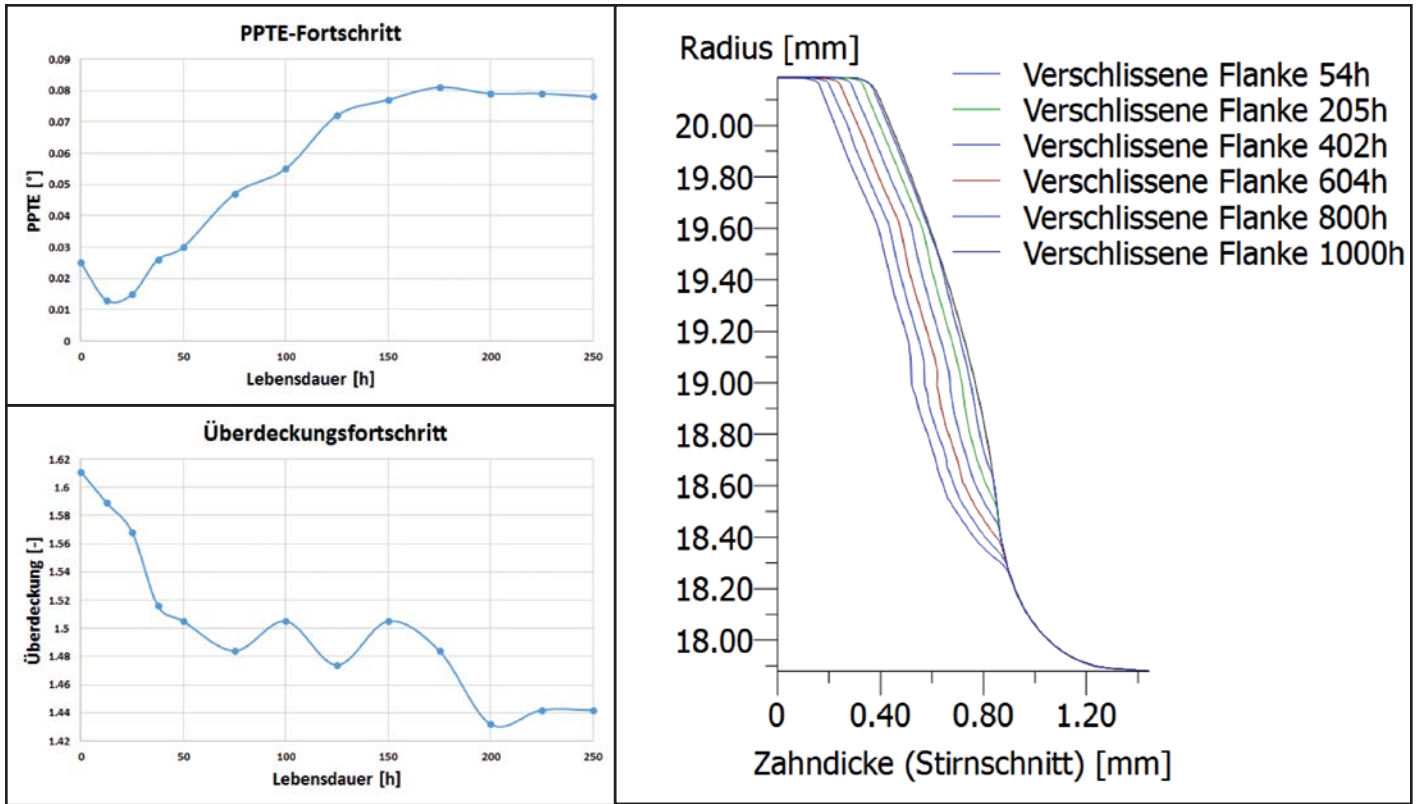

Figure 4 Left top: Progression of PPTe over the service life. Left bottom: Change in the transverse contact ratio. Right: Worn tooth flank in several steps up to 1000 h.

progressed. Closer investigation of the development of transmission error over the operating time shows an initial improvement in the transmission behavior. It is generally accepted that gear units which have been properly run in have a better load capacity because the load distribution has a tendency to improve during the running-in period. This “running-in effect” obviously also applies to the transmission error.

However, as the wear increases, the transmission error also increases sharply until it reaches a plateau. The fact that the transmission error does not then continue to increase, but remains at a specific, high level, can be explained as follows: a certain level of equilibrium is achieved where the tooth thickness continues to decrease but the tooth form no longer changes very much. This is illustrated by the worn flanks in Figure 4. After the green tooth form (operating time of approximately 200 h) the following tooth forms display a similar progression, where the thickness reduces at a constant rate.

Summary

Two calculation methods are now available for calculating wear: The first is an analytical method which uses simple formulae to determine the average wear when designing gear systems (Refs. 1, 3). The second, more complex method, is integrated in contact analysis and is used to ascertain the progression of wear.

When these calculation methods are compared with measurements taken by test rigs (plastic and metal) and with results from real life situations, it can be seen that these methods produce very usable, realistic results. Therefore, it is now also possible to predict the effect of a worn tooth form on the load distribution and transmission error. **PTE**

References

1. VDI 2736, Sheet 2: Thermoplastische Zahnräder – Tragfähigkeitsberechnung Stirnräder. VDI Düsseldorf, 2014.
2. Feulner, R. Verschleiss Trocken Laufender Kunststoffgetriebe, Dissertation, Erlangen, 2008.
3. Kissling, U and S. Hauri. “Das Phänomen Kaltverschleiss von Stirnrädern – Neu Berechnet.“ Tagungsband SIMPEP, 2014.

Ph.D.Eng. Ulrich Kissling

studied machine engineering at the Swiss Technical University (ETH) in Zürich, followed by a doctorate. He is the founder (1998) and CEO of the company KISSsoft AG.



M.Eng. Sandro Hauri

was trained as a mechanical engineer at the Swiss Federal Institute of Technology in Zurich (ETH) and specialized in Robotics. He joined KISSsoft AG after his studies as a development engineer.



For Related Articles Search

wear

at www.powertransmission.com





X-life
proven to be better



Lasts longer.

Get more value out of your machines and equipment.

Higher dynamic load ratings: the key advantage of Schaeffler rolling bearings and linear products bearing the X-life seal of quality. For product designs that deliver higher performance and machines that operate more cost-effectively, we invite you to choose from our extensive line of X-life products.

-  X times longer service life
-  X times greater load-carrying capacity
-  X times more efficient use of space



▶ schaeffler.com/X-life



SCHAEFFLER

Desktop Engineering – How to Calculate Dynamic and Static Load Ratings

Norm Parker

Introduction

When comparing bearing suppliers, engineers are often left with few options other than to compare dynamic load ratings and corresponding life calculations. Of course, we can look at steel and manufacturing quality; but if we are comparing sources of similar quality, those items may not provide a large contrast. It often surprises people to learn that bearing capacities are calculated values, not tested values. Lately, however, a trend is emerging for bearing suppliers to increase their ratings for higher performance bearings that have premium features such as higher quality steel and specialized heat treatment. Bearing companies are under intense competitive pressure to make every feature add to the dynamic capacity of their bearings because it is very well understood that an increase in capacity adds to the bottom line. As a result, it is important that the end user develop a keen understanding of how capacity ratings and subsequent life calculations are generated in order to make a true comparison, or be left to comparing the claims of well-heeled marketing departments.

Dynamic Capacity

Nearly every calculation surrounding bearing life begins with the dynamic capacity, C_r . C_r is the equivalent load that would result in an average service life of one million revolutions. The formula is imperfect and standard bearings aren't designed to handle 100% of C_r ; but, those are annoying nuances we have to understand and live with. In the past, most bearing companies would follow the dynamic capacity formula to ISO or ABMA standards and then increase the resulting life calculation by some factor based on heat treatment and other

premium features in addition to the increase that would come through ISO 281 or 16281 using a-iso factors. The issues that end users have with this is that enhanced life calculation factors are not always shown on the bearing print and the print is the primary legal document that exists between the end user and the bearing manufacturer. Some end users interpret this as being an escape route for the bearing companies if something goes wrong – which it is not. Consequently, the competition and end users are pushing bearing companies to increase capacity ratings on the print. This is where the math starts getting fuzzy. We will walk through the formula with a couple of real bearings and determine where these numbers are coming from. The ISO/ABMA C_r formula:

(1)

$$C_r = b_{mf} f_c (i L_{we} \cos \alpha)^{7/9} Z^{3/4} D_{we}^{29/27}$$

b_m	Rating factor for contemporary, commonly used, high quality hardened bearing steel in accordance with good manufacturing practices, the value of which varies with bearing type and design). ISO defines this value for tapers as 1.1
f_c	Factor which depends on the geometry of the bearing components, the accuracy to which the various components are made, and the material
i	Number of rows
L_{we}	Effective roller contact length
α	Bearing half angle (cup angle)
Z	Number of rollers per row
D_{we}	Mean roller diameter
D_{pw}	Pitch diameter of roller set



Figure 1 Company A (Left), Company B (Right).



Figure 2 Measuring major and minor inner raceway diameters for D_{pw} .



Figure 3 Measuring roller length for L_{we} .



Figure 4 Measuring roller ends for D_{we} .

For this example, let's look at two high-quality competitors, each producing their own design of the HM804846/10, a popular inch-series tapered roller bearing. We'll refer to these as Company A and Company B.

Right off, we see b_m is defined by ISO as 1.1. For i , both bearings have 1 row; $i=1$. The bearing half-angle, α , will be provided by the manufacturer, so we can skip that measurement. Both of these bearings are around 20° (though a side-by-side comparison clearly shows they are not identical angles). Z , the number of rollers, is easy enough to count—both have 18 rollers. The remaining values— f_c , L_{we} , D_{we} and D_{pw} —are often not provided, but we can physically measure these features. Customer models will typically leave off just enough features to prevent an accurate measurement. We could get fancy and have these set up on a CMM and measure to 3 decimal places, but if you glance at the load ratings in the catalog you will see everything is rounded to

the nearest 500 N. None of these factors will change your results greater than the rounding error if you are within 0.5 mm of accuracy. This sounds like a job for calipers.

We will skip f_c for now because that is a tabulated value which we need two of our other unknowns for. Let's start with the effective roller length L_{we} . ABMA defines L_{we} as:

The theoretical maximum length of contact between a roller and that raceway where the contact is shortest. NOTE: This is normally taken to be either the distance between the theoretically sharp corners of the roller minus the roller chamfers, or the raceway width excluding the grinding undercuts—whichever is the smaller.

The roller chamfer can be hard to identify with the naked eye, and will usually involve a little guesswork.

Usually, the L_{we} will be 1-1.5 mm shorter than the entire length of the roller. We can check ourselves before we are done, so don't worry too much

about your estimate for now. For a 21 mm roller, an L_{we} of 19.5 mm is a good guess.

Now on to D_{we} —the mean roller diameter. This is very straightforward; measure the large diameter at the bottom and the small diameter at the top and average the values for D_{we} .

The final measurement, D_{pw} , is also fairly simple. D_{pw} , the pitch diameter of the roller set, is the theoretical centerline that the rollers run on. This is measured in similar fashion as were the rollers; measure the large and small diameters of the inner ring raceway; take the average to find the diameter in the center, and then add 1 D_{we} to get the pitch diameter at the center of the rollers, at the center of the raceway.

With those values measured, we can now find f_c , which is a tabulated value based on the quotient.

$$\frac{D_{we} \cos \alpha}{D_{pw}} \quad (2)$$

For example, Company A

$$D_{we} = 10.2$$

$$D_{pw} = 71.2$$

$$\alpha = 20$$

The quotient calculates to:

$$\frac{10.2 \cos 20}{71.2} = .135$$

$$\therefore f_c = 87.4$$

$\frac{D_{we} \cos \alpha}{D_{pw}}$	f_c
0.01	52.10
0.02	60.80
0.03	66.50
0.04	70.70
0.05	74.10
0.06	76.90
0.07	79.20
0.08	81.20
0.09	82.80
0.10	84.20
0.11	85.20
0.12	86.40
0.13	87.10
0.14	87.70
0.15	88.20
0.16	88.50

Figure 5 f_c Table.

Let's compare our values and results: Plugging these values back into the formula:

$$C_r = 1.1 \cdot 87.4 (1 \cdot 21.3 \cdot \cos 20)^{7/9} 18^{3/4} 10.2^{29/27}$$

C_r Company A: 104,675 N
 C_r Company B: 106,144 N

If your calculated value is more than 1% different than the published value, adjust the L_{we} until the calculated C_r matches the book value.

HM804846/10		A	B
Material constant (ISO value is 1.1)	b_m	1.1	1.1
Geometry dependent factor	f_c	87.4	87.4
number of rows	i	1	1
Effective roller contact length	L_{we}	21.3	21.6
bearing half angle (cup angle)	α	20	19.37
Number of rollers per row	Z	18	18
Mean roller diameter	D_{we}	10.2	10.2
Pitch diameter of roller set	D_{pw}	71.2	71.1

Figure 6 Measured values for Co.'s A and B.

Static Capacity

By definition, the static capacity C_{or} is the calculated maximum-recommended static load value which loosely represents the yield point of the bearing steel. Ideally, this value should represent peak stress levels around 4,000 MPa—the ISO-recommended stress limit. Just due to geometry, the highest stress will occur on the inner ring/roller interface. The ball-ball contact between the inner ring and roller has a smaller contact area than the ball-socket contact pattern on the outer ring. C_{or} is a useful maximum load value if you don't have bearing software to calculate actual stress values. The benefit with using stress values is that the effects of crowning can be taken into account, and if the bearing has premium heat treatment features that produce a harder surface, stress values up to 4,200 MPa or higher may be permissible. Comparing catalog values of C_{or} can be very useful because there are no places to add non-standard factors; the formula is completely based on geometry. If you need a quick comparison for the physical amount of steel contact between two different bearings, forget C_r — C_{or} is what you want to compare.

The other good news is, if you collected your C_r values, you already have everything you need to calculate C_{or} .

$$C_{or} = 44 \left(1 - \frac{D_{we} \cos \alpha}{D_{we}} \right) i Z L_{we} D_{we} \cos \alpha \tag{3}$$

C_{or} Company A: 139,926 N
 C_{or} Company B: 142,337 N

If a bearing company wanted to increase the static rating on paper for a premium bearing, they could easily justify using a 4,200 MPa as a baseline for their rating, though it is not standard

ISO/ABMA practice and not a fair comparison to another company that is strictly following ISO standards.

Let's compare all of our calculated values next to the published catalog values for both companies.

The calculated values for Company A came within 1% of the published values. However, something is quite different with Company B; the published C_r is 38% higher than our calculated value and the published C_{or} is 10% higher than our calculated value. Company A claims to have similar quality and performance as Company B, but we certainly cannot ignore the fact that Company B has a 41% higher C_r and a 12% higher C_{or} . This is a significant difference between two relatively similar bearings. What is going on here?

Company B claims that they have lab-tested proof to show that their increased C_r is legitimate and they do not want to be held to an artificially low ISO or ABMA formula, and therefore do not adhere to the standards. On the other hand, Company A claims that they are able to add a performance factor to the calculated L_{10} life that will give them nearly the same calculated life as Company B. Let's revisit the basic L_{10} formula so that we can play along:

$$L_{10} = \left(\frac{C_r}{P} \right)^{10/3} \tag{4}$$

	Company A	Company B
C_r Calculated	104,675	106,144
C_r Published	104,000	147,000
$C_r \Delta \%$	-0.6%	38%
C_{or} Calculated	139,926	142,37
C_{or} Published	140,000	157,000
$C_r \Delta \%$	0.1%	10%

Figure 7 Calculated vs. published values.

Where L_{10} is measured in millions of revolutions and P is the applied load. Mathematically, an increase of X in C_r does this:

$$L_{10} = \left(\frac{X \cdot C_r}{P} \right)^{10/3}$$

While a performance factor does this:

$$L_{10} = X \cdot \left(\frac{C_r}{P} \right)^{10/3}$$

Because C_r is raised to the exponent of 10/3, a small increase nets large increases in calculated L_{10} . Let's see what type of performance factor a 38% increase in C_r would yield:

$$X = (1.38)^{3/10}$$

$$X = 3.2$$

This means that company A could multiply their calculated L_{10} by 3.2 times and effectively match the results of Company B. Company A states they are comfortable going with a performance factor of 2.6, but not 3.2 (Note: Until recently, Company B had a C_r of 141 kN that was exactly equivalent to a 2.6 performance factor. Two completely separate companies *coincidentally* had performance factors of 2.6). What the end users want the bearing companies to do is take the 2 or 2.6 performance factor and increase C_r by that amount on the print rather than just increasing the calculated L_{10} . For example, a performance factor of 2 would mean:

$$2 = \left(\frac{X \cdot C_r}{P} \right)^{10/3}$$

Let $C_r/P = 1$, then $X = 1.23$. This means that every 23% increase in dynamic capacity doubles the calculated life. End users want to see $1.23 \times C_r$, rather than $2 \times L_{10}$. The perceived benefit is that the increased C_r is shown on the print—which is a *legal document*. The risk in doing this for the bearing companies is that, right or wrong, some engineers are accustomed to designing to rules of thumb based on the published C_r . If C_r is artificially increased on the print, these practices may very easily result in a bearing that is under-designed for the application in terms of operating load and peak static stress.

The increased rating for C_{or} is easier to explain. As mentioned earlier, if you calculate the load required to reach a higher-than-ISO-recom-

mended peak stress value of 4,000 MPa, you can easily justify the higher rating on the print. Though again, this is not standard practice.

From here it becomes difficult to make a rational decision, because there seems to be a lot of subjectivity going on with the calculations. We have tested vs. calculated dynamic load ratings, performance factors that have questionable origins, and less-than-obvious methods of increasing static load ratings. Recall the earlier statement that the static load rating calculations can be valuable for comparison. If we only compare *our* calculated static capacities (recall, true steel on steel contact area) we see a marginal difference of only 1%.

With that, we absolutely know that we have similar amounts of surface contact area. Armed with the knowledge that we have comparable geometry between the two bearings, the only real performance difference should be in the rolling fatigue performance of the steel. Again, we are assuming these are both top-shelf companies, so bearing design, manufacturing quality, surface finishes, etc., *should be* comparable. All of the fancy calculation methods beyond this point are useless for comparing these two bearings; only dyno or field performance tests over the entire loading range will conclusively separate the two. These formulas are easy to set up in a spreadsheet format that will facilitate future comparisons and provide real insight when dealing with your bearing suppliers.

Conclusion

There is an undeniable level of comfort when you see a huge capacity rating on a print that puts your safety factors well into “good night’s sleep” territory. It can be argued that both Companies A and B have valid points in the way they handle the premium features. One does not want to be held to capacity ratings that they can outperform by 50%, and the other does not want to deviate from the standards.

The main point of this article is to show that load ratings are based on simple formulas that you can calculate on your own. You should ask a prospective supplier if their capacity ratings and life calculations are based on ISO 281:2007 and ISO 76:2006. If not, you need to completely understand how and why they are using their value. Likewise for any performance factors added to the calculated L_{10} life; double-check their work and ask questions. Secondly, a supplier is not off the hook just because they don’t put their performance factor on the print. If their calculations are well-documented with all of the latest information you gave them, their analysis is a legal form of communication (though be forewarned—contamination levels, temperatures, alignment, roundness of shaft and bores...all of the factors that go into ISO 281 are subject to review). Finally, capacity ratings are pushed from an engineering and marketing perspective. Companies are expected to live up to their ratings, but with the wide scatter of failure points in any type of fatigue test, it can be difficult to pinpoint a true 20% difference during bench or field testing with a limited number of parts. We need to account for genuine high-performance features on our bearings because we use those factors in our designs. Just be sure that you know how to compare the different methods being used to account for those features. **PTE**



References

1. Brandlein, Eschmann, Hasbargen and Weigand. *Ball and Roller Bearings: Theory, Design and Application*, Third Edition, Wiley & Sons 1999.
2. International Organization for Standardization. *Rolling Bearings: Static Load Ratings*,
3. ISO 76:2006(E), ISO 2006, Third Edition, 2006-05-01.
4. International Organization for Standardization. *Rolling Bearings: Dynamic Load Ratings and Rating Life*, ISO 281:2007(E), ISO 2007, Second Edition 2007-02-15.
5. American Bearing Manufacturers Association. *Load Ratings and Fatigue Life for Roller Bearings*, ANSI/ABMA 11:2014 (Revision of ANSI/ABMA 11:1990).

For Related Articles Search

load

at www.powertransmission.com

Norm Parker is the bearing technical specialist for the driveline division at General Motors LLC. Located onsite at the Milford (MI) Proving Grounds, he is regularly tasked with testing theoretical models in the real world, in real time. With his bachelor and master degrees in mechanical engineering from Oakland University (Rochester, Michigan), Parker has developed a keen interest in the academic, commercial and engineering aspects of the bearing industry. Prior to joining GM, he rose through the ranks of traditional bearing companies; by so doing he acquired invaluable experience in working with some of the largest customers — with the toughest applications and demands — on the planet. Parker plans to continue expanding his expertise and providing substantial personal contributions to bearing technology through metallurgy, design and processing.



Variable Speed Pump Drives For Industrial Machinery — System Considerations

Paul Stavrou

The changing landscape of hydraulic drives is leading many fluid power specialists to quickly adapt to using variable speed pump drives. Optimum utilization of these drives requires, in many cases, additional system design considerations.

Despite ominous predictions in the '80s and '90s, the complete replacement of hydraulics with electrical drives did not occur—fluid power still plays an important role in modern drive technology. Moreover, it is impossible to imagine many fields of industry working without hydraulic drives.

The enormous power density makes hydraulic drives irreplaceable when large forces and high torques are required. Over the last 30 years “traditional” hydraulics has evolved into electrohydraulics, where the integration of electronics and closed-loop controls has become an industrial standard.

For years it was common to depict hydraulics as “strong but stupid.” Today this reputation no longer applies; hydraulics are not only strong, but also intelligent. Modern fluid power drives are perfect examples of highly integrated, mechatronic devices.

Drive for More Advanced Solutions

Ongoing competition with electrical drives and ever increasing requirements of performance and energy efficiency have led the hydraulic drive industry to new and more advanced system solutions.

The power control of electrohydraulic drives typically uses resistive or volumetric control.

In resistive control, the system is controlled by a valve, usually a proportional device, to throttle oil flow delivered from a power supply source. In volumetric control, flow is controlled by adjusting the displacement of a pump or



Figure 1 The newest generation of hydraulics technology, such as Rexroth's Sytronix variable speed pump drive system, integrates powerful, energy-efficient hydraulic pumps with advanced, intelligent electronics and controls.

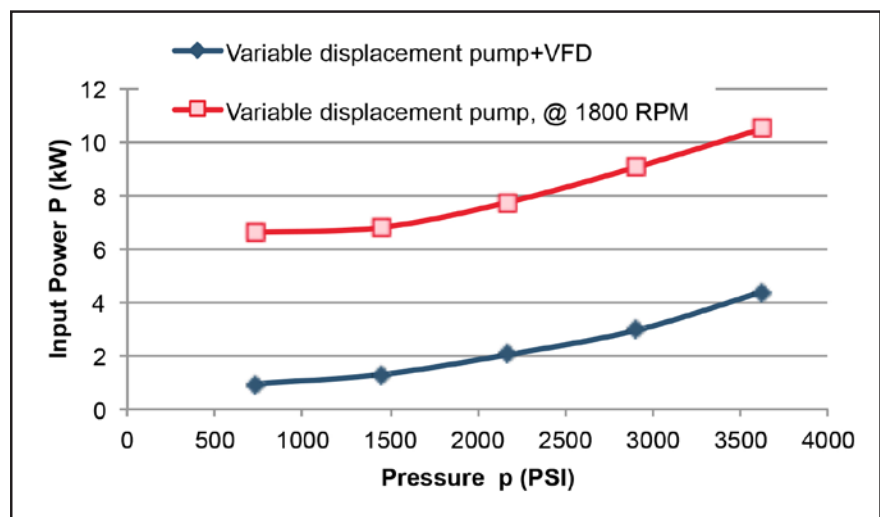

Figure 2 Shown is power consumption, in a dead-head condition, for a 125cc axial piston pump driven by a 100 HP premium efficiency motor. The energy used is considerably lower when using a VFD, as compared to a constant speed drive.

Technology Trends

- Intelligent electrohydraulics enable much greater control and flexibility
- Significant improvements in system energy efficiency thanks to use of variable speed pump drive technology
- Reduction of throttling losses lowers oil reservoir cooling requirements
- Using variable frequency drives with hydraulic power units can lower average noise emissions by 10-20 dB (A)

Key Considerations

- Dynamic performance and power requirements determine the choice of the motor
- Select motor and drive size based on pressure-flow-time cycle (p/Q profile) for the application
- When selecting pumps, consider suitability of pump construction for variable speed operation
- Also consider mechanical and volumetric efficiency of the pump at the design operating points

by directly changing the drive speed of a fixed or variable displacement pump. Resistive control possesses excellent dynamic characteristics; however it exhibits poor energy efficiency. Significant power losses occur due to dissipation in the control valve. This is, in effect — hydraulic resistance.

There are a number of broad manufacturing trends that are influencing the increased interest in and potential value of variable speed pump drives:

- Rising costs of energy and increased awareness of environment issues have resulted in new trends in drive systems. Over the last two decades, improvements in electro-hydraulic efficiency were a main goal of many companies and research institutes. Given advances in drive technology and closed loop control, the resistive throttling method is being replaced more often by more efficient volumetric control, using speed variable pump systems.
- Reducing throttling losses lowers the amount of heat transferred to the oil and oil reservoir. Lower heat generation allows for a smaller capacity cooling system and lower parasitic power needed to maintain optimum oil temperature.
- Using variable frequency drives (VFDs) with hydraulic power



Figure 3 The Sytronix DFE variable speed pump combines high dynamics and high power output for pressure, flow and power control applications.

units can also lower average noise emissions, as the pump speed is reduced during partial load operations, such as pressure holding or idling. The average sound level can be lowered by as much as 10-20 dB (A), improving environmental working conditions.

Growth of Variable Speed Pump Drives

The combination of advanced electric drive technology and hydraulics opens a new chapter in electrohydraulic drive systems. Machine builders can now benefit from the traditional hydraulic characteristics of robustness and power density and additionally benefit from the well-known advantages of electric drives, i.e. — inherent drive “intelligence” and ease-of-integration with factory automation systems.

This changing landscape of hydraulic drives has pushed fluid power specialists to quickly adapt to using variable speed pump drives. But for many engineers, this may not be an easy step. Optimum utilization of variable speed pump drives requires, in many cases, additional system design considerations and modifications to a hydraulic system design.

Fluid power engineers need to understand the distinctive features of VFDs and the requirements of the production process being driven. This will

define the critical points for the electric and hydraulic elements. The goal of the system is to meet the requirements of dynamics and accuracy, but also to maintain focus on overall energy efficiency. When applying a VFD-driven pump, using a conventional induction motor or a permanent magnet servo motor (PMM), the dynamic behavior will differ from a traditional system using a constant speed pump drive and throttling control valve.

System Design Options

Systems using variable speed pump drives can use a number of different design solutions. The selection of the design solution depends on a number of factors. The type of hydraulic circuit, the required response times and accuracy, the power required and other factors all come into play when deciding the best drive and circuit design.

Dynamic performance and power requirements determine the choice of the motor. For applications requiring the fastest response times and highest accuracies, a PMM may be the best selection. Today this technology is used extensively in plastic injection molding machines. These drive systems offer extremely high performance and have high productivity rates.

Due to their high power density and low drive inertia, PMMs have the high-

est acceleration capabilities. These high dynamics allow complex machine control tasks, such as direct force, speed and cylinder position control to be realized without proportional valves. The main limitation when using PMMs is maximum continuous output power—typically less than 60kW. Power units with higher output power, greater than 60kW, may require multiple PMM-pump groups.

Standard asynchronous induction motors driven with VFDs can be used in higher power applications, or where direct control of high dynamic axes is not required. Using standard induction motors with VFDs, operating in a sensor-less vector control mode (no separate motor feedback device required), results in a cost-effective system. However, the system designer should be aware of the limitations of direct control using these drives.

The system response times can be long as a result of the high inertia of the induction motor. Variable speed pump drives using standard induction motors with VFDs are used today in the woodworking industry, on press applications, in plastics machinery, heavy industry applications and machining tool applications where the control task is typically regulating system pressure or flow.

Selecting Motor Size

The motor size and drive should be selected based on the pressure-flow-time cycle (p/Q profile) for the application machine. In practice, motors on standard HPUs are often sized on “corner power,” calculated from the maximum pump pressure and flow, and duty cycle is commonly not taken into account. This results in the installation of excess motor HP. If partial load comprises a significant portion of the machine cycle, the excess motor power can be significant.

Sizing PMMs for variable speed pump drives should follow methods commonly used in electromechanical actuator drives; calculating the root mean square (RMS) value based on the load torque and average drive speed. Once a pump size is determined, the motor torque and speed are calculated from the required pump pressure and

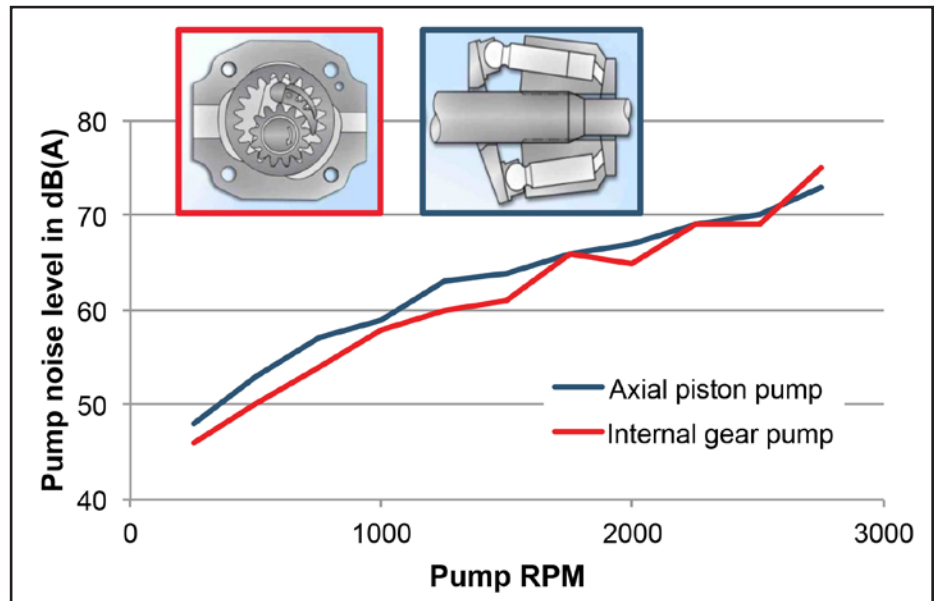

Figure 4 Using VFDs with hydraulic power units can lower average noise emissions. Since the pump speed is reduced during partial load operations, average sound levels can be reduced by as much as 10-20 db (A).

flow. Additionally, the dynamic torque requirements for accelerating and decelerating the motor’s rotor and pump inertia needs to be added.

These calculated values are used to select the proper size drive and motor. Drive sizing and system optimization can be done using specialized tools, such as Bosch Rexroth’s *SytronixSize*, which allows analyzing p/Q profiles and motor load factors. For a more complex analysis, a numerical simulation can be used to model the system.

Dynamic simulations help by providing more insight to the system dynamics, such as pressurization dynamics, and to investigate interactions between the drive and the hydraulic system. Analysis of the performance of closed-loop controls can be done as well. These dynamic simulations can be carried out using software that includes drive- and hydraulics-model libraries. Simulation tools, such as Bosch Rexroth’s *Simster 3*, *ITI SimulationX* or *MATLAB/Simulink Simscape* can be used for these requirements.

Pump Selection Criteria

When selecting the pump for variable speed operation, several important factors must be considered:

- Is the pump construction suitable for variable speed operation?

- What are the minimum- and maximum-allowed RPMs for the pump?
- Can the pump be used bi-directionally, and if so, are there any pressure and speed limitations?
- Is the pump suitable for start and stop operation?
- What is the maximum operating pressure allowed for the pump, and does pressure affect the maximum-allowable pump speed?
- What fluid will be used in the system and does it limit the pump’s pressure and speed, based on viscosity and pump lubrication?
- What is the mechanical and volumetric efficiency of the pump at the design operating points?
- Consider pump acoustic noise level—based on expected speed, pressure, and displacement.
- What will be the pressure and flow pulsations over the range of operating speeds?
- Is the hydraulic circuit of open or closed type?

Improper pump selection or operation beyond allowed conditions can result in premature pump failure or sub-optimal control performance. Pumps used with speed variable drives are typically internal gear or piston pumps. In some cases, properly selected vane pumps may also be used.

Internal gear pumps are characterized by high-efficiency, low-flow ripple, low-mechanical inertia and high-pressure capability. Due to these character-

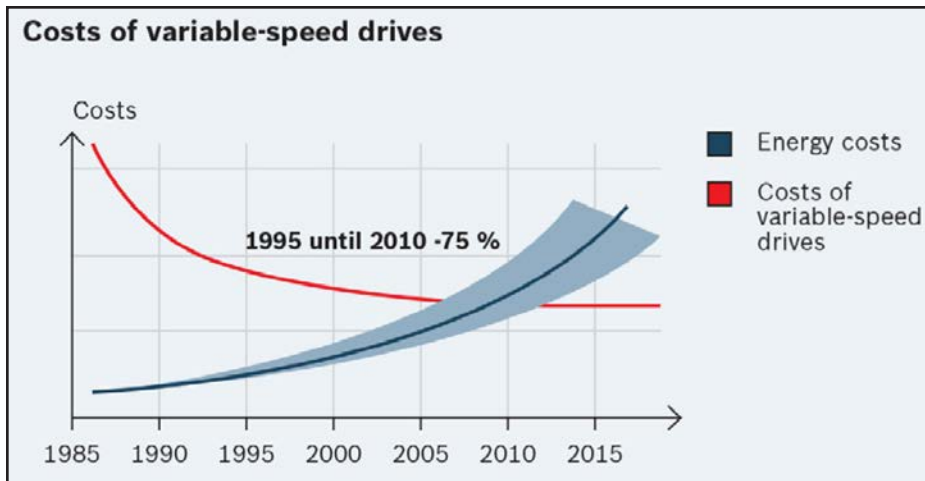

Figure 5 In recent years the cost of using variable-speed drive technology has become more economical, making it effective to combine variable-speed electric drives with hydraulics to provide an energy-saving, high-performance alternative for use in many applications.

istics they are widely used with PMMs on injection molding machines. The limitations are fixed displacement and limits on the minimum drive speed during pressure holding operation.

Axial piston pumps, of either fixed or variable displacement design, have the desired property of high efficiency at low speed, making them ideal for pressure holding operation. Using a variable displacement pump allows the possibility of reducing the motor torque during pressure holding in the machine cycle. This can result in higher system efficiency since the motor and pump can operate under more desirable conditions. High-response variable displacement pumps, such as Rexroth's DFE n 5000, can have reac-

tion times an order of magnitude faster than a VFD- driven induction motor. Combining this pump with a VFD-controlled, induction motor, results in greater efficiency and much higher system response than a sole variable speed alone; it is of greater value when used with higher HP-drive motors.

It is expected that in the future speed-variable pump drives will replace an increasing number of standard motors in hydraulic power units. This change is already utilized by many plastic machinery OEMs, and is quickly expanding in press applications. Understanding the principles of variable speed drives and the interaction between hydraulics and electric drives will be key to future fluid power engineering. **PTE**

For more information:

Bosch Rexroth Corporation
14001 South Lakes Drive
Charlotte, NC 28273-6791
Phone: (800) 739-7684
www.boschrexroth-us.com

For Related Articles Search

pump drives

at www.powertransmission.com

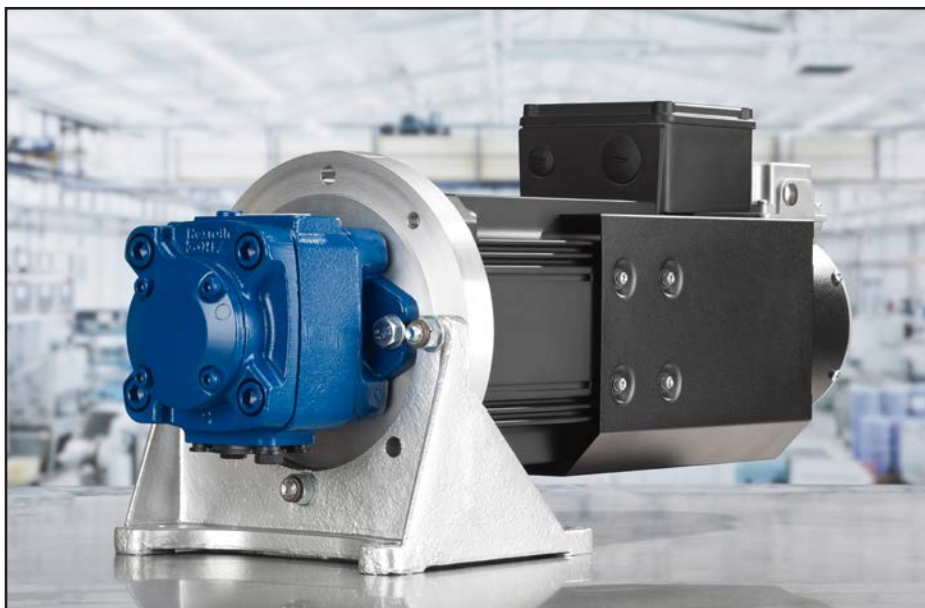

Paul Stavrou possesses 39 years' experience in the fluid power industry — working in marketing, engineering and development for electro-hydraulic components and systems. He holds a degree in electrical engineering from Lehigh University and three patents for electronic control systems. Stavrou is manager of system applications at Bosch Rexroth Corporation in Bethlehem, PA.



Gear Fault Diagnosis by Motor Current Analysis: Application to Industrial Cases

François Combet

The use of motor current signature analysis (MCSA) for motor fault detection — such as a broken rotor bar — is now well established. However, detection of mechanical faults related to the driven system remains a more challenging task. Recently there has been a growing interest for detection of gear faults by MCSA. Advantages and drawbacks of these MCSA-type techniques are presented and discussed on a few industrial cases.

Introduction

Reliance upon motor current signature analysis (MCSA) for fault detection has received growing attention in recent years. Electrical current analysis is a very useful tool for the diagnosis of faults inducing torque or speed fluctuations, and provides ideal vibration analysis (Ref.1). First works were focused on motor fault diagnosis, such as broken rotor bars or eccentricity faults (Ref.2). Recent works are considering more challenging faults such as bearing faults (Refs. 3-4), or even gear faults in the driven gearbox (Refs. 5-7). This work is of great interest in applications where the mechanical system is not easily accessible for traditional vibration measurements; e.g., in the nuclear industry.

In Reference 5 the authors propose a theoretical model based on Kron's transform—a close form to Park's transform—that leads to an equivalent, two-phase machine from the initial three-phase motor. The resulting vector is called the current space-vector and rotates with the stator magnetic field. When considering the meshing of gears, the tooth mesh stiffness is normally varying because the number of teeth in mesh is periodically varying in time. Moreover, when a faulty tooth is coming into mesh the stiffness is dropping suddenly, thus inducing a reduction of the load torque and consequently of the current space-vector amplitude. The resulting theoretical current spectrum should then display harmonic components spaced by the rotation speed of the faulty gear on the entire frequency range (Ref.3).

In Reference 6 it was proposed to synchronously average the stator current space-vector amplitude with the rotation of each gear in the driven gearbox. The method was applied to a test bench with a two-stage reduction gearbox where a fault was created on one tooth of the output gear. Results were very promising when compared with the averaged vibration signal.

It should be noted, however, that most of these studies are concerned with test benches of low power and low inertia. This is relatively far from industrial systems, which may be constituted of high-power motors driving a high-inertia load. So far, there have been very few works to our knowledge that show the application of the MCSA-based techniques and large induction motors; and we only found a few studies that focus on motor faults exclusively (Ref.2). No work really addressed what the limitations are of the MCSA-based techniques for the detection of gear or bearing faults, and whether these techniques are applicable or not to large, industrial systems. In addition, in practice the current spectral signature is polluted by high-frequency components (rotor slots components and harmonics of the supply frequency) that add difficulty in making a diagnosis.

In this paper we will attempt to apply the MCSA-based techniques for the detection of gear faults based on industrial-environment case studies. The use of one-phase (1I) stator current may be sufficient in the case of low-rotation speed of the faulty gear. However, in other cases the three-phase (3I) stator currents will be necessary in order

to compute the current space-vector or Park's vector, whose advantage is to bypass the Bedrosian's conditions associated with the Hilbert transform. We will then apply the synchronous averaging techniques in order to detect and enhance the local tooth faults. Possibilities and limitations of these techniques are discussed.

Effect of Small Torque Variation On Stator Current

Let us consider a small torque variation applied to a mechanical system constituted of the elements from the driving AC motor to the mechanical element submitted to a load variation (due, for example, to a cracked tooth on one gear). By neglecting the frictional forces, it writes:

$$J d\Omega/dt = \Gamma e - \Gamma load \quad (1)$$

With

J Total moment of inertia of the system

Ω Rotational speed of the motor (we consider here only one shaft for simplicity)

Γe Electro-mechanical torque of the motor

$\Gamma load$ Loading torque applied to the system.

In normal operating conditions, i.e., when Ω is close to the synchronous speed Ω_s of the motor, the torque characteristic may be linearized as:

$$\Gamma e = Km * s = Km * (\Omega_s - \Omega) / \Omega_s \quad (2)$$

with Km a constant depending of the motor characteristics and s the motor slip. Now by considering a small variation of the load torque $\delta\Gamma$ load occurring during the time interval δt , by applying these small perturbations to (Eq. 1) and (Eq. 2) we obtain:

$$J\delta\Omega/\delta t = \delta\Gamma e - \delta\Gamma_{load} = Km\delta\Omega/\Omega_s - \delta\Gamma_{load}$$

$$\delta\Omega = -\delta\Gamma_{load}/[J/\delta t + Km/\Omega_s]$$

It appears that the effect on the induced speed variation $\delta\Omega$ will be reduced when:

Moment of inertia J of the system is important

Time interval δt of the torque variation is small; i.e. the torque variation is of high-frequency nature

Constant Km of the motor is high (note that this constant is related to the motor supply voltage and will be higher for a high-voltage motor)

With the stator current of the motor being directly linked to the motor torque Γe — which is itself related to the speed from Equation 2 — the induced current variation δI will follow that of $\delta\Omega$. As well, other parameters will impact motor torque variations, e.g.: the type of gears (spur, helical), the type of the mechanical coupling of the motor that will add a filtering effect between the load torque and the motor torque, etc.

From this simple analysis it is clear that the effect of small load torque variations in the driven mechanical system on the stator current of the driving motor is strongly dependent on a few parameters: moment of inertia, frequency of the torque variation, type of the motor and of the gears. Therefore we can expect different behaviors depending on the system under analysis.

Application to Industrial Cases

We will consider here two case studies where a gear fault was present in the reduction gearbox driven by an induction motor. In the first case only one phase current (II) will be analyzed due



Figure 2 Two-stage reduction gearbox.

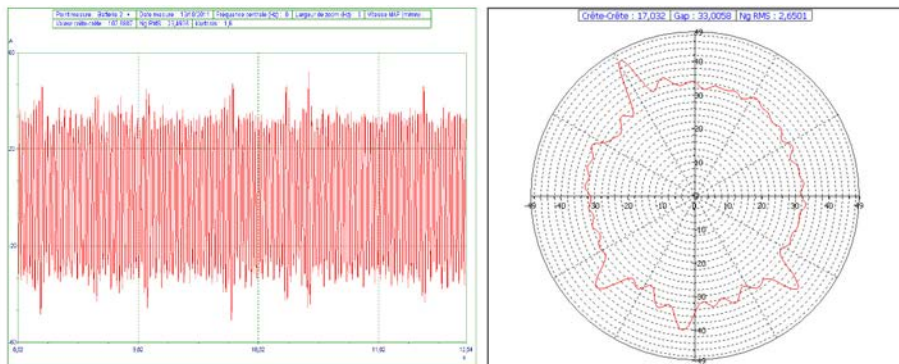

Figure 1 Stator current signal (left) and AMF profile averaged over the rotation period of the geared roll (right).

to a low rotation speed. On the second study the three-phase current (3I) will be necessary in order to compute the Park's vector. Synchronous averaging will also be applied in order to enhance the local tooth faults (Refs. 6-7).

Gear fault detection in a paper making machine. This application deals with the diagnosis — by means of electrical current analysis — of local gear faults in a drying roll section of a paper making machine. The system is composed of a low-voltage AC motor (30kW/1,480 rpm) running a pinion through a 6.1 reduction gearbox. The pinion has 32 teeth and is meshing with a 178-tooth ring gear attached to the driving roll of the section. The rotation of the rolls is rather slow (0.63Hz), which gives a gear mesh frequency at 112Hz.

The operator observed on the current indicator abnormal and apparently random variations of the instantaneous current absorbed by the motor (Fig. 1). The stator phase current was measured and the amplitude modulation function (AMF) of the current 50Hz fundamental component was computed and then averaged synchronously with the rotation period of the rolls. The AMF av-

erage profile shows four stronger peaks (Fig. 1) that seem to indicate local tooth faults on the main geared roll. Indeed, when dismantling the gear at inspection, the operator literally observed “several falling teeth.”

Note that here the rotation period of the rolls is low enough so that only one stator phase measurement is necessary for the demodulation of the 50Hz carrier frequency (the 25Hz span of the AMF spectrum contains about 40 harmonics of the gear rotation frequency). While the moment of inertia of the rolls is relatively high, that of the driving system (medium-size motor, small reduction gearbox and output pinion) is relatively small. Thus we seem to satisfy here the abovementioned conditions for the detection of torque fluctuations via stator current analysis.

Gear fault in a ball mill. This application deals with a ball mill machine driven by two AC motors — each through a two-stage reduction gearbox. The motors are 2MW power, 5kV voltage and 1,000 rpm speed; the gears are chevron-type.

During one experiment it was known from the operator that the high-speed pinion of one gearbox had one cracked

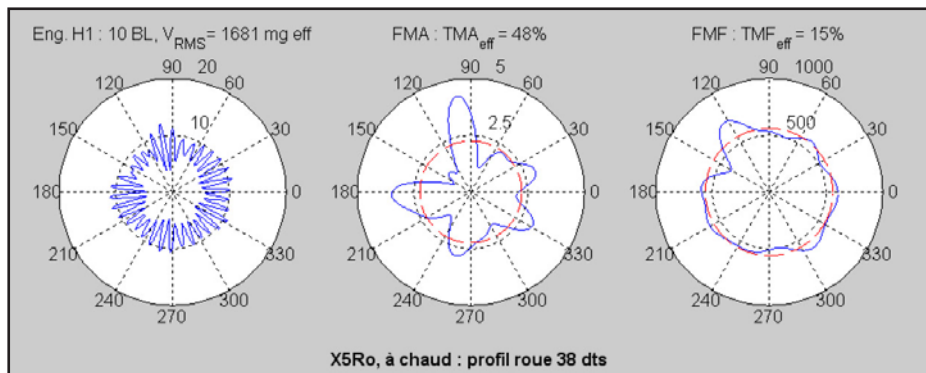

Figure 3 Synchronous averaged vibration profile of the high-speed gear with a cracked tooth.

tooth (the gearbox was to be replaced one month later). The synchronous time averaging technique applied to a vibration measurement performed on the gearbox clearly shows a strong, localized modulation of the associated profile of the 38-tooth, high-speed pinion (Fig. 3).

The three-phase stator current of the motor was also recorded. With the rotation frequency of the faulty gear being higher here (16.5Hz), the classic 50Hz demodulation technique will only give information on the 1x torque fluctuation, and not on the rapid torque variations within the rotation period. Therefore in this case the Park's vector approach will be used.

The three-phase stator currents $i_{1-3}(t)$ can be represented by a complex vector, also known as "space-vector" or Park's vector, defined as:

$$i_{\text{park}}(t) = \frac{2}{3} [i_1(t) + a \cdot i_2(t) + a^2 \cdot i_3(t)], \quad (5)$$

with $a = \exp(j2\pi/3)$

It can be shown that the modulus and phase of Park's vector correspond respectively to the instantaneous amplitude and phase modulations of each of the three-phase currents—regardless of modulation and carrier frequencies (Ref. 4). Thus by taking advantage of the three-phase current measurements, the Park's vector analysis allows quick implementation of the demodulation process in the event of a fast-modulated signal and thus to bypass the Bedrosian's conditions associated with the Hilbert transform.

Figure 4 shows the frequency spectrum of the Park's vector modulus. A few strong components can already be observed at 18x the motor speed and at 72x (this one probably corresponds to the slot frequency of the motor). The crosses positioned on the motor rotation harmonics indicate a few harmonics in the low-frequency range; yet note that the mesh frequency at 38x (623.3Hz) is barely visible here.

The Park's vector modulus was then synchronously averaged with the rotation speed of the motor. The result is shown (Fig. 5, left) where the 18x fluctuation is clearly visible. Note that this effect is likely due to the motor construction; for a 72-slot rotor we have

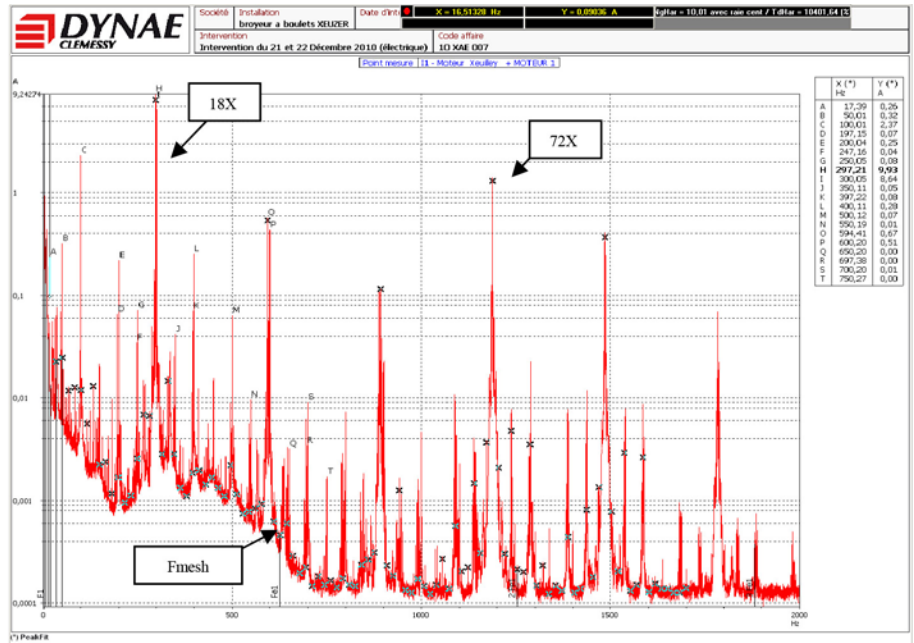

Figure 4 Spectrum of Park's vector modulus.

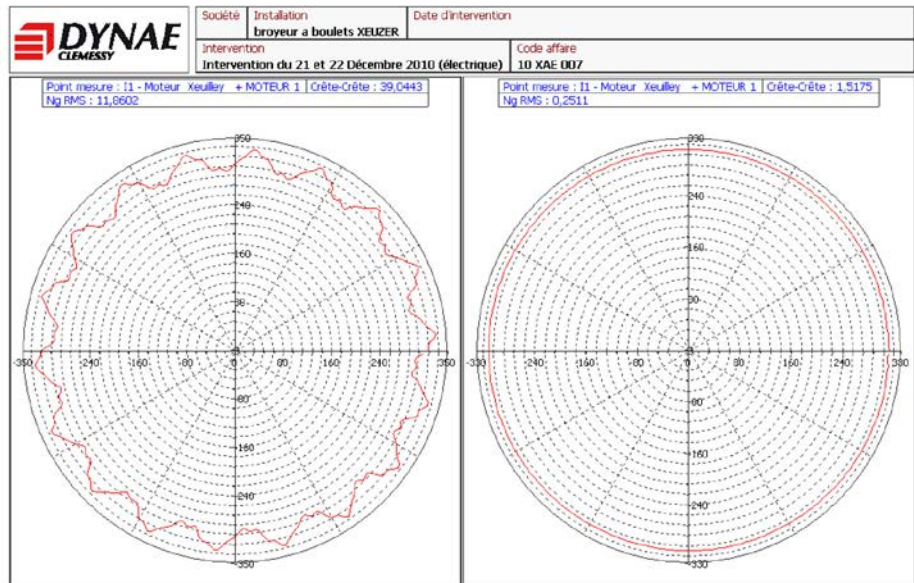

Figure 5 Averaged profile of Park's vector modulus (left); with 18x harmonics removed (right).

$72/6/3 = 4$ slots-per-pole and per-phase, which makes 18 groups of 4 slots. We also obtained exactly the same profile after the gearbox was changed. On Figure 5 (right) the 18x harmonics were removed: the profile does not indicate any fluctuation here. Therefore we may conclude that the motor does not "see" any torque fluctuation related to the cracked tooth on the high-speed pinion.

Nevertheless, the Park's vector may yet contain some valuable information; by comparing the spectrum low-frequency band before and after the

change of the gearbox, we can see some changes, especially a torsional resonance located at 35Hz that has shifted at a lower frequency (32.5Hz) after the change. Note that as the motor coupling was also changed, this may correspond to the coupling torsional resonance (as the new coupling seems to have a lower stiffness).

This rather disappointing result can be explained by the fact that we are in a quite different configuration, as compared to the first case study—i.e., higher power and high-voltage motor, higher mechanical inertia, and higher

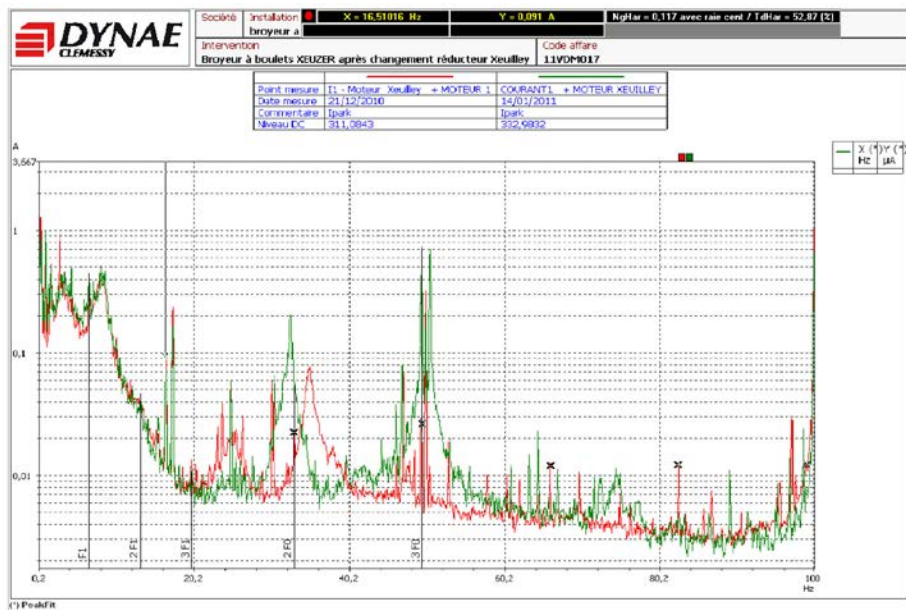

Figure 6 Comparison of the Park's vector low-frequency spectrum before (red), and after (green), the change of the gearbox and the motor coupling.

frequency of the induced torque fluctuation. Moreover, the chevron-type gears and the coupling may also have an influence by filtering out the torque fluctuations seen by the motor and re-lected in the stator current.

Conclusions

It was the intent of this paper to demonstrate—with industrial applications as examples—the application of the stator current-based-techniques for the detection of small torque fluctuations such as those induced by gear faults in the driven gearbox.

Most of the literature on this subject reports successful detection, but fails to mention the limitations of the method in terms of mechanical parameters, which are:

- Moment of inertia
- Type of the motor and of the gears
- Effect of the coupling, frequency of the torque fluctuation (i.e. the rotation speed of the faulty gear)

We have shown in two examples that the influence on the stator current can be very different, depending on context. An interesting continuation of this work would consist of predicting the detection capabilities of the stator current-based techniques in each case, and based on better knowledge of the influence of each of the mechanical parameters. **PTE**

References

1. Pachaud, C. "L'Analyse de l'Intensité du Courant Statorique : Outil de Surveillance et de Diagnostic," *J3eA, Journal sur l'Enseignement des Sciences et Technologies de l'Information et des Systèmes*, Vol 4, Hors-Série 4, 12 (2005).
2. Thomson, W.T. et al. "Online Current Monitoring to Diagnose Air Gap Eccentricity in Large Three-Phase Induction Motors — Industrial Case Histories Verify the Predictions," *IEEE Trans. on Energy Conversion* (14) 4, (1999).
3. Blödt, M. et al. "Models for Bearing Damage Detection in Induction Motors Using Stator Current Monitoring," *IEEE Trans. on Industrial Electronics* (55) 4, (2008).
4. Baptiste, T., M. Chabert, J. Regnier and J. Faucher. "Hilbert vs. Concordia Transform for Three-Phase Machine Stator Current Time-Frequency Monitoring," *Mech. Syst. & Signal Process.* 23 (2009) 2648–2657.
5. Feki, N, G. Clerc and P. Velez. "An Integrated Electromechanical Model of Motor Gear Units — Applications to Tooth Fault Detection by Electric Measurements," *Mech. Syst. & Signal Process.* 29, 2012, 377–390.
6. Ottewill, J.R. and M. Orkisz. "Condition Monitoring of Gearboxes Using Synchronously Averaged Electric Motor Signals," *Mech. Syst. & Signal Process.*, 2013.
7. Combet, F. "Gear Fault Diagnosis and Industrial Applications," *5th Int. Congress on Technical Diagnostics*, Krakow, Sept. 2012.

For Related Articles Search

motors

at www.powertransmission.com

François Combet completed his PhD thesis at Grenoble, France, on the subject of signal processing methods applied to cable transportation systems vibration modelling. He subsequently moved to the UK, taking a position as a Research Fellow at Cranfield University and working on various industrial projects related to gearbox fault diagnosis. Dr. Combet is currently working with DYNAE, a leading French company in the field of machinery diagnosis based on vibration and electrical measurements.



Revolvo

ASSISTS IN SEWAGE TREATMENT ON THE RIVER THAMES

The sewage treatment works at Beckton, on the River Thames, is the largest in the UK and has to treat a vast volume of waste water. Part of the treatment process involves a sludge thickener tank, which uses a rotating structure, known as a picket fence. When the bearing that supported the picket fence failed, Thames Water required some expert assistance from Revolvo to ensure the replacement bearing would deliver the required performance.

The picket fence thickener consists of a tank with a central column, to which is fixed a steel structure containing vertical bars and scrapers for the tank floor. The whole structure rotates slowly inside the tank, powered by a motor and gearbox, with the weight of the picket fence supported by a slewing ring.



Waste water is constantly fed into the thickener tanks, which allow the solids to settle to the bottom, where they are pumped to the next process and the clarified liquid is decanted to a secondary treatment process. In this particular case, the thickener tanks are covered to reduce odor pollution, so the level of wastewater in each tank is determined by the limit switches, as any manual, visual check of these levels is very difficult.

The level switches are used to start and stop the pumps that supply the thickener tanks with wastewater for processing. Unfortunately, in this case, they had been disconnected and the liquid level in the tank had risen to a point where it had submerged the slewing ring. Continued operation in this environment proved to be detrimental to the bearing. The first sign of a problem was the noise from the rapidly failing bearing.

On-site engineers soon established the nature of the problem and determined that a new slewing ring would be required, along with some additional engineering to raise the position of the bearing to prevent a similar failure in the future. This type of bearing is not a stock item and required Revolvo to design and manufacture a custom replacement.

The design called for a cross roller slewing ring, over 1,800 mm in diameter, with gear teeth on the outer diameter

to engage with the drive gear. Under normal circumstances such an assembly would require 20 weeks to complete, but the urgency in this case required that the job was completed in 10 weeks. At the same time as the slewing ring was being manufactured, the site engineers worked on installing a steel plinth, which would raise the bearing above the maximum level of liquid.

The engineers also designed and installed a new drive system and a remote lubrication arrangement that would ensure reliable operation of the cross roller bearing without the need for regular servicing by the site maintenance team. Once installed, the picket fence thickener was returned to normal service.

Raj Batra

ELECTED TO NEMA'S BOARD OF GOVERNORS

The National Electrical Manufacturers Association (NEMA) recently voted for **Raj Batra**, president of Digital Factory for Siemens USA, to serve on the Board of Governors during its recent annual meeting in San Diego.

Batra will serve a two-year term expiring in 2016. The Digital Factory division of Siemens offers a comprehensive portfolio of seamlessly integrated hardware, software and technology-based services in order to support manufacturing companies worldwide in enhancing the flexibility and efficiency of their manufacturing processes and reducing the time to market of their products.



"We are pleased to have Raj Batra join the NEMA Board of Governors and work with other leaders in the electroindustry during a period of exciting opportunities," said Kevin J. Cosgriff, NEMA president and CEO. "His experience and insights will contribute greatly in the months and years ahead."

Joining Siemens in 1993, Batra has held a variety of high-level management and sales positions including president of industry automation, vice president and general manager of automation and motion division, and director of automotive and aerospace businesses. Prior to Siemens, Batra worked as a sales engineer and product manager developing automation solutions for discrete manufacturing and process industries. Batra earned a Bachelor of Science in Electrical Engineering from Lawrence Technological University in Michigan and a Master of Business Administration from the University of Michigan.

NEMA is the association of electrical equipment and medical imaging manufacturers, founded in 1926 and headquartered in Rosslyn, Virginia. It's nearly 400 member companies manufacture a diverse set of products including power transmission and distribution equipment, lighting systems, factory automation and control systems, and medical diagnostic imaging systems. Total U.S. shipments for electro-industry products exceed \$100 billion annually.

Aurelio Banda

BECOMES PRESIDENT OF BECKHOFF AUTOMATION

Beckhoff Automation recently announced that Aurelio Banda will become the company's president of North American operations (Beckhoff Automation LLC), effective January 1, 2015. The subsidiary's current president, Graham Harris, will assume a regional management role as part of a planned transition from the leadership role he has held since 2003.

As president, Banda will oversee all operations at the headquarters of Beckhoff Automation LLC in Savage, Minn. where administration, sales and marketing, customer service, and technical services/support are managed. The Savage facility also houses a repair and modification center, customer training area, and the main warehouse for Beckhoff North America.

"Beckhoff Automation has seen tremendous business development and yearly revenue increases in North America under the leadership of Graham Harris," Hans Beckhoff, founder and managing director of Verl, Germany-based Beckhoff Automation GmbH. "He oversaw the continuous expansion of the company in all areas for over a decade, and



Cabat[®]
A Division of A&E Incorporated

Designed to Protect™

Overload Release Clutches

Phone: 262.554.7500
Fax: 262.554.7503
www.cabatinc.com

BEYTA GEAR SERVICE

PUTTING A LIFETIME OF GEAR DESIGN EXPERIENCE TO WORK FOR YOU

- Reverse engineering
- Gearbox upgrades
- Custom gearbox design
- Specification development
- Project management
- Vendor qualification
- Design reviews
- Bid evaluations
- Tooling design
- Customized gear training
- Equipment evaluation
- Custom machine design

Charles D. Schultz
chuck@beytagear.com
[630] 209-1652

www.beytagear.com

grew the subsidiary's revenue from \$5 million in 2003 by more than 20% each year on average to a projected \$60 million by the end of fiscal year 2014. I thank Graham Harris for his proven track record of success and dedication to serving the machine builders and manufacturers of North America.

"Banda, the new president of Beckhoff Automation LLC, is a well-known automation expert who is well-equipped to continue the positive business development we have grown accustomed to in North America."

Hans Beckhoff's positive outlook on the North American automation market has led him to expect the regional subsidiary to increase its growth by continuing to promote the company's "New Automation Technology" philosophy, based on PC Control, TwinCAT automation software, a comprehensive portfolio I/O solutions, and high performance motor and drive technologies.

Summarizing over a decade of leadership, Graham Harris stated, "After 11 exciting years serving as president of Beckhoff North America, I will transition into a regional management role based in the southeast U.S. In my new, regionally-focused role, I look forward to continue promoting the most advanced automation technologies in the industry while collaborating with a highly-skilled team of colleagues and innovative customers."

Numerous milestones in a history of success in automation technology and business signal a strong future for Beckhoff North America.

"I am honored by this opportunity to lead Beckhoff's North American business, and I see even brighter developments in our future," Aurelio Banda, the subsidiary's incoming president, added. "Since the company's inception, Beckhoff Automation has led the convergence of automation technology (AT) and IT standards, resulting in great success for customers who embrace PC-based control as their foundation. Today this has only accelerated, with the full integration of computer science programming standards in TwinCAT 3 automation software, and with full support of OPC UA as the communications standard for Industry 4.0 and the Internet of Things. This creates unique competitive advantages for our North American customers.

Voith

SENDS 1,000TH TPKL FLUID COUPLING TO DATONG COAL MINING GROUP

Voith recently manufactured their 1,000th fluid coupling type TPKL. The coupling will go to the DaTong Coal Mining Group in China. The fill-controlled fluid couplings will be used in a 6.4 MW belt conveyor drive. The 3,160 meter long underground belt conveyor is driven by four 1,600 kW motors, with a planned capacity of 4,000 tons per hour. The belt conveyor will transport coal uphill at a 14 degree angle.

"We are very happy to use fill-controlled couplings from Voith running in our belt conveyors," said DaTong's Manager of the Mechanical and Electrical Department.

Voith started the production of the TPKL coupling series in 1997. This fluid coupling type was especially developed for demanding belt conveyor applications in mining. The coupling type provides torque limitation for a smooth start-up of the belt conveyor. It allows active load sharing with multi-motor drives.

DaTong Coal Mining Group Co., Ltd. is located in DaTong City, a province Shanxi, China. It is one of the top three coal groups in China, with a coal production capacity of 152 million tons per year. The coal group operates a large number of coal mines across the country. Many of them use Voith fluid couplings in diverse underground applications like AFCs, belt conveyors, stage loaders and crushers.

Altra

DESIGNS OVERLOAD PROTECTION SOLUTION FOR METAL SHREDDER

An international metals recycler was suffering from recurring damage to the motors and universal joints caused by torque overload when the shredder rotors jammed because of an un-shreddable obstruction.

During each jam, the torque generated was so excessive that damage was being caused to the components within the drive train, such as the universal joint bearings and even the motor itself. In this instance not only could the repair



bill be costly, but the downtime could be considerable while the obstruction was cleared and the drive train repaired or replaced. In total, up to 48 hours of downtime was required each time the rotors jammed.

In an effort to save on maintenance costs and reduce downtime, the site manager turned to Ameridrives, a division of Altra Couplings, to see if its engineers could design a solution. As a manufacturer of industrial couplings, Altra Couplings develops custom solutions for most industries which incorporate reliability with reduced operation costs.

Having assessed the application, Altra's engineers designed an overload protection solution into the universal joints which would protect the components within the drive train in the event of a jam. An Americarden U3440 universal joint was modified to incorporate a shear pin overload device. When a rotor jam occurs, and torque reaches in excess of 533,000 Nm, the pins shear, disengaging the driven end of the universal joint from the driving end and protecting the components from damage.

The solution also meant that, after clearing the jam, a maintenance crew can replace the pins and have the shredder operational in less than four hours - reducing downtime by over 95 percent.

Dan Jones

RECEIVES EMERF AWARD FOR 'OUTSTANDING CONTRIBUTIONS'

Dan Jones, president and owner of Increation Associates, recently received the EMERF 2014 award for "Outstanding Contributions to the Electric Machines Industry."

Jones, an electric motor and generator design engineer, was presented the lifetime achievement award from EMERF (Electric Motor Education and Research Foundation) and SM-MA-Motors and Motion Association, during their annual fall conference awards dinner last month.

Jones has worked in the motion control industry for over 54 years. He has had his own consulting company, Increation Associates, for over 32 years, where he has specialized in designing high-torque and high-power density brushless PM and brush PM motors, as well as high-efficiency AC induction motors and generators. His motors range from 2 watts to 500 kilowatts. Jones has written and presented over 265 articles and papers on various elements in motion control in the U.S. Europe and Asia.



Gear Solutions

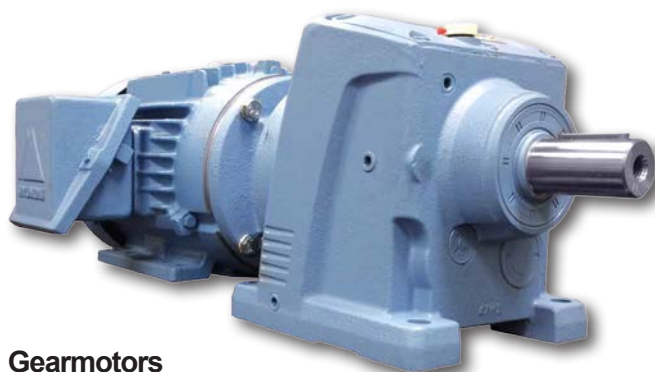

Gearmotors

- 5:1 - 120:1 ratios
- 1 HP to 75 HP
- Drop-in for most major brands

**CALL US NOW TO GET
YOUR SPECIAL PRICING!**

Inline Helical Speed Reducers:

- 2:1 - 120:1 ratios
(other ratios available as custom orders)
- Box sizes 37 - 147; 1/4 HP to 75 HP
- Drop-in for most major brands



WorldWide Electric Corporation / 1-800-808-2131 / www.worldwideelectric.net

ITAMCO

GETS INVITE TO GRID CELL PROGRAM

Indiana Technology and Manufacturing Companies (ITAMCO) was recently invited to display their technology products at the Advanced Materials and Composites Grid Cell in Ann Arbor, MI.

On display will be ITAMCO's MTConnect Glassware app for Google Glass and their iBlue product. The Google Glass application is an award-winning MTConnect Challenge project that gathers and shares machine data provided by MTConnect. iBlue is the first handheld bluetooth transmitter that collects production data and sends it to bluetooth-enabled smartphones, tablets and computers with iOS, Android, Windows, Blackberry, and Linux operating systems. iBlue can wirelessly transmit temperature readings, metal hardness readings, and USB HID input from a keyboard, micrometer, caliper, barcode scanner or any other USB HID-enabled device that's free of proprietary hardware interface or software.

ITAMCO initially presented the two products at the Digital Manufacturing Revolution 2014 conference that was hosted by the National Center for Manufacturing Sciences (NCMS). The NCMS then asked ITAMCO to participate in the Grid Cell program. A Grid Cell is an innovation center where manufacturers get hands-on experience and training with digital manufacturing tools. Grid Cells were developed by



the NCMS — a non-profit group member-based consortium — whose objective is to drive the global competitiveness of North American manufacturers through collaboration, innovation, and advanced technologies. Grid Cells will provide businesses with a virtualized approach to manufacturing that combines high performance modeling, simulation and analysis (MS&A), data mining tools, and the digitization of processes to optimize speed, reliability, and efficiency.

"We're really excited about this concept," said Joel Neidig, an engineer and leader of the technology product development team at ITAMCO. "It's a great way for machine shop personnel to get hands-on experience with digital technology. I like that you can walk in and Grid Cell staff will show you around and explain the technology on display."

Power Transmission Engineering online!

It's like your own professional superpower.

Stronger, faster and smarter than your average website, www.powertransmission.com offers everything you need to supercharge your engineering-oriented organization.

- Complete archive of articles on engineered components
- Directory of suppliers of gears, bearings, motors and other mechanical power transmission components
- Product and Industry News updated daily
- Exclusive online content in our e-mail newsletters
- The Bearings Blog
- Calendar of upcoming events
- Comprehensive search feature helps you find what you're looking for – *faster than a speeding bullet!*

www.powertransmission.com



GREAT SCOTT!

It's the future!

OK, you blinked and missed last month's issue of *Power Transmission Engineering*. Fortunately, you don't need a DeLorean to travel back in time – just a computer and working fingers.

Hop online and visit www.powertransmission.com to view the entire magazine, including these exclusive features:

- Getting a Piece of that Sweet Coupling Pie
- The Small Motor Rule – How Will it Affect You?
- Ask the Expert – Pre-tension Thrust Bearings
- Applications of Bevel Gears

...and much more!

www.powertransmission.com

Bill Mills

NAMED VICE PRESIDENT OF SALES AND MARKETING FOR DAYTON LAMINA

Dayton Lamina recently added **Bill Mills** to the executive management team in the position of vice president of sales and marketing. Working from the Dayton Headquarters, Mills has responsibility for all U.S. sales and marketing functions for the company's varied divisions including Dayton Progress, Lamina, Danly, IEM, and Lemppo.



Mills joins Dayton Lamina from Davis Standard Company. Prior to that he was with GE Plastics, and later its current owner Azdel, Inc., where he held several sales and marketing management positions of increasing responsibility.

"We're excited to add Bill to the Dayton Lamina team," said Dayton Lamina President Alan Shaffer. "His strong experience in industrial sales and marketing will come to bear as Bill leads the recently combined sales and marketing team of Dayton Progress and Anchor Lamina, which merged in February 2014. Customers and sales channel partners will appreciate Bill's professionalism, work ethic, positive outlook and the results that we can achieve by working together."

Power Transmission/ Motion Control Industry

ANTICIPATES CONTINUED GROWTH IN 2015

The *PTDA Business Index* for 4Q2014 indicates slowing but continued positive growth. However, manufacturers reported more positive growth in new orders, employment, supplier deliveries and inventories for 4Q2014 than distributors, a notable change from 2Q and 3Q 2014. Despite this upward swing, the overall 4Q2014 *PTDA Business Index* reading of 66.5 was slightly lower than the previous quarter's reading of 67.5. Both distributors and manufacturers anticipate 2015 to be another year of positive growth.

[Note: The index reading indicates the rate of change compared with the previous period. For example, a reading of 50 indicates no change from the prior period while readings above 50 indicate growth and below 50 indicate contraction. The further the index is above or below 50 suggests a faster or slower rate of change.]

The entire 4Q2014 *PTDA Business Index* report is available through PTDA's website at ptda.org/index. It includes distributor and manufacturer breakout data in addition to historical data. The *PTDA Business Index* is modeled after the widely respected Purchasing Managers Index and tracks change in business activity, new orders, employment, supplier deliveries, inventories, prices and backlog in the PT/MC industry to arrive at an overall index.

GET THE BIG PICTURE

Subscribe today!

GLOBAL INDUSTRIAL OUTLOOK

Concise, visual, information rich analysis of global manufacturing demand and trends organized by geographic regions and key industry verticals. Built on proprietary, granular collection and organization of core growth trends in orders and sales from 55 key global companies.

Published Quarterly: February, May, August, November

Regular price: \$400 (only \$350 for PTE subscribers)

Money back guarantee

Langenberg &
Company

Subscription requests to:

Ewa@Langenberg-llc.com

www.Langenberg-LLC.com

USA

RESOURCES

Oil & Gas →

Mining →

POWER & ENERGY

Generation →

Transmission ↑

Distribution ↑

TRANSPORTATION

Road →

Rail →

Marine →

MACHINERY

Construction ↑

Mining →

Truck →

Agriculture →

AUTOMATION

Process ↑

Industrial ↑

FLOW CONTROL

↑

IND. MACHINERY, GEN IND.

CONSTRUCTION

HVAC →

C&I →

Residential ↑

CONSUMER

Automotive ↑

Appliances ↑

Electronics ↑

AVIATION

Commercial ↓

Military ↓

Hungry for More?



Everything you need if you buy gears, bearings, motors, couplings and clutches.

Power Transmission Engineering

- Product and Industry News Updated Daily
- Directory of Mechanical Power Transmission Suppliers
- Exclusive online content in our e-mail newsletters
- Back Issues and Article Archive
- Calendar of Upcoming Events for power transmission professionals

FREE SUBSCRIPTION!

www.powertransmission.com

March 4-7 – The MFG Meeting Orlando World Center Marriott, Orlando, FL. The MFG Meeting brings together the entire manufacturing industry for a unique conference experience that provides unparalleled educational and networking opportunities. Engage with the industry's thought leaders and discuss business solutions with peers – all in one place. One of the highlights of this year's conference will be a training session with Michael Hoffman, president of Igniting Performance, a company that specializes in sales, leadership and building customer loyalty. His innovative program, "Secrets of the 1%ers," taps into the methods and the motivations of the best of the best – showing how they became influential – and how to replicate their success. For more information, visit www.themfgmeeting.com.

March 9-11 – SIAF Guangzhou 2015 China Import and Export Fair Complex, Guangzhou, China. The 2015 edition of SPS – Industrial Automation Fair Guangzhou is gearing up to be a must-attend industrial automation event in China. The event will cover over 40,000 square miles of exhibition space across four halls. Recognizing the importance and future growth prospects of the South China market, exhibitors are ready to present their latest collection of innovative solutions and products to international and domestic visitors. To date, over 300 exhibitors are confirmed to introduce the latest industrial automation technologies, including control systems, sensor technologies, software development, drive systems, components and much more for manufacturing-based industries. For more information, visit www.spsinchina.com.

March 23-26 – Automate 2015 McCormick Place North, Chicago, IL. Automate is the largest solutions-based showcase of automation technologies in North America. Formerly the International Robots, Vision & Motion Control Show, which dates back to 1977, Automate now demonstrates the full spectrum of automation technologies and solutions for a broad array of industries. Companies that provide integration of automation, robotics and machine vision will show actual demonstrations of systems that will allow attendees to see live demos solving challenges they face in their industry, and also to learn from solutions used in other industries that may be beneficial to them. The rest of the show features the latest automation, robotic, vision and motion control technologies and systems on display from leading global suppliers. A comprehensive educational conference accompanies the Automate show. Featuring a broad array of classes from beginner to advanced skill levels, the conference offers something for all attendees. This conference has been consistently rated high-quality and high-value, delivering a training experience that is immediately worthwhile. Keynote speakers include Steve Wozniak, cofounder of Apple. For more information, visit www.automateshow.com.

March 24-26 – 2015 Gearbox CSI: Forensic Analysis of Gear & Bearing Failures Concordville Hotel and Conference Center, Concordville, PA. This seminar helps gear designers gain a better understanding of various types of gears and

bearings. Learn about the limitation and capabilities of rolling element bearings and the gears that they support so you can properly apply the best gear-bearing combination to any gearbox, whether simple or complex. Following this seminar, participants will be able to apply their understanding of forensic analysis of gearbox failures in future gearbox designs, discuss bearing and gear types, explain how bearing selection is influenced by gear type and loading, select appropriate bearing types and configurations as influenced by gear type and loading, and explain how to optimize bearing and gear combinations. Cost of admission is \$1,895 for members and \$2,395 for non-members. For more information, visit www.agma.org.

April 29-May 1 – 2015 AGMA/ABMA Annual Meeting The Meritage Resort and Spa, Napa Valley, CA. This year's Annual Meeting will address the key issues facing manufacturing and offer opportunities to network, make memories, forge relationships, and build on future partnerships. Napa Valley provides much to explore and many attendees will bring a spouse or guest. In lieu of the golf tournament, the planning committee opted to keep open the second afternoon for exploration of this unique location. For more information, visit www.agma.org.

March 4 – MDM Webinar: Introduction to Permanent Magnet AC Motors Industrial customers are beginning to consider advanced motor technologies, such as permanent magnet motors (PMAC), to improve production efficiency and boost their bottom lines. Unlike standard induction motors, which induce a secondary magnetic field in the rotor, PMAC motors use high-performance rotor magnets and advanced designs to create a magnetic field that is always present. This eliminates the secondary circuit rotor I²R (heat) losses found in the induction-motor design, resulting in higher efficiency and a better power factor to boot. The Motor Decisions Matter campaign has invited two motor manufacturers to describe permanent magnet motor technology in basic terms, including their advantages, limitations and requirements. For more information, visit www.motorsmatter.org.

May 4-6 – 2015 Gearbox System Design: The Rest of the Story...Everything but the Gears and Bearings Sheraton Sand Key Resort, Clearwater Beach, FL. This course focuses the supporting elements of a gearbox that allow gears and bearings to do their jobs most efficiently. Learn about seals, lubrication, lubricants, housings, breathers, and other details that go into designing gearbox systems. This seminar starts with the basics including some history of design and the varied environments to which gearbox systems are built. It continues by teaching detailed design layout. And it then will focus on individual pros and cons of types of housing construction, drawing practices for housings and related components and selection and role of gearbox accessories, such as breathers, filters, screens, sight gages and other level indication devices. For more information, visit www.agma.org.

HANNOVER MESSE. Are you **ready** for

the **4th Industrial Revolution?**

13 – 17 April 2015
Hannover • Germany

hannovermesse.com

Find out about
the factory of the
future – and all
the latest trends.

Partner Country
India 2015



Deutsche Messe

Get new technology first



AGMA (Gear Expo)

Page 21
www.gearexpo.com

Arrow Gear

Page 5
www.arrowgear.com

Automation Direct

Inside Front Cover
www.automationdirect.com

B&R Machine and Gear

Page 9
www.brgear.com

Baldor

Page 27
www.baldor.com

Beyta Gear Service

Page 53
www.beytagear.com

Brevini Gear

Page 16
brevinigear.com

Brother International

Page 29
BrotherGearmotors.com

Cabat Inc.

Page 53
www.cabatinc.com

Circle Gear

Page 25
www.circlegear.com

Diequa Corp.

Pages 10, 14
www.diequa.com

Excel Gear

Page 30
www.excelgear.com

First Gear

Page 23
www.first-gear.com

Forest City Gear

Page 35
www.forestcitygear.com

Framo Morat

Page 32
www.framo-morat.com

Hannover Messe

Page 61
Hannovermesse.com

J.W. Winco

Page 2
www.jwwinco.com

Langenberg & Co.

Page 58
www.langenberg-llc.com

McInnes Rolled Rings

Page 19
www.mcinnesrolledrings.com

Miki Pulley

Page 12
www.mikipulley-us.com

Motion Industries

Page 31
www.motionindustries.com

Ningbo Zhongyi Hydraulic Motor Co.

Page 33
www.zihyd.com

Precipart

Page 13
www.precipart.com

R+W America

Page 15
www.rw-america.com

Rave Gears and Machining LLC

Page 11
www.ravegears.com

Schaeffler Group

Back Outside Cover, Page 39
www.schaeffler.us

Sesame Motor Co.

Page 17
www.sesamemotor.com

SEW-Eurodrive

Inside Back Cover
www.seweurodrive.com

SKF

Page 3
www.skf.com

Smalley Steel Ring Co.

Page 26
www.smalley.com

Sterling Instrument

Page 7
www.sdp-si.com/precision

Suhner Manufacturing

Page 2
www.suhner.com

Worldwide Electric Corp.

Page 55
www.worldwideelectric.net

CALL FOR PAPERS!

Are you sitting on an idea for a technical paper but wondering where to present it? Do you have one already written, sitting on your desk, gathering machine dust?

How about *Power Transmission Engineering*? We are always looking for gearing- and power transmission component-relevant technical papers for publication in the magazine and in its digital version. Having your work appear in *Power Transmission Engineering* guarantees you an audience of the most experienced and discriminating industry players. You say your work has not been peer-reviewed? Not a problem, as we are lucky—and thankful—to have on-hand

some of the most experienced and brilliant minds in the industry—our technical editors. So if your work “passes muster” and is published, you’ll know you were reviewed by the best—and most demanding.

Chances are you’ll be creating the paper under the auspices of the company for whom you work or own, or for one of the various industry-relevant associations. That means they as well will bask in the reflected glory that accrues with publication in *Power Transmission Engineering*.

For publication guidelines and more information, please contact Jack McGuinn at jmcguinn@powertransmission.com.

Power Transmission Engineering



Power Transmission Engineering is Your KEY to understanding Gears, Gear Drives, Bearings, Motors, Clutches, Couplings, Brakes, and other Power Transmission Components.

Unlock your FREE subscription by filling out this form.

FREE SUBSCRIPTION

1 **YES** I want to receive/continue to receive **Power Transmission Engineering** FREE!
 No thank you.

Name: _____ JobTitle/Position: _____
(print)

Signature _____ Date: _____
(required)

2 E-mail _____
(So we can notify you when the online edition is available)

 **SAVE a TREE!**
 I ONLY want the digital edition (e-mail required)

3 Please update your contact information or attach you business card here. (No Staples)

Company Name: _____
Address: _____

City: _____
State/Province: _____ ZIP+4/Postal Code: _____
Country: _____
Telephone: _____ Fax: _____
E-mail: _____
Website: _____

5 My company's principal product or service is: _____

6 What is your primary job function responsibility? (Check one)

<input type="checkbox"/> Corporate Management (1)	<input type="checkbox"/> Quality Control (7)
<input type="checkbox"/> Plant Engineering (2)	<input type="checkbox"/> Factory Automation (8)
<input type="checkbox"/> Design Engineering (3)	<input type="checkbox"/> Maintenance (9)
<input type="checkbox"/> Marketing & Sales (4)	<input type="checkbox"/> Other (10)
<input type="checkbox"/> Manufacturing Engineering (5)	
<input type="checkbox"/> Purchasing (6)	

Is there a colleague within your company that might benefit from having their own copy of **Power Transmission Engineering** magazine?

Name: _____
Title: _____

4 How is THIS LOCATION involved with power transmission products? (Check all that apply)

WE MAKE power transmission products (10)
 WE BUY power transmission products (12)
 WE SELL power transmission products (Distributors, sales reps. etc.) (14)
 WE DESIGN products with power transmission components in them. (16)
 Other (please describe) (15) _____

DIGITAL SUBSCRIPTIONS

YES, I want to be notified each issue when *Power Transmission Engineering* is available online

YES, I would like to receive *Power Transmission Engineering's* monthly e-mail newsletter

YES, I would like to receive *Power Transmission Engineering's* twice monthly e-mail Product Alerts

YES, I would like to receive 3rd-party e-mails from *Power Transmission Engineering's* advertisers and partners

YES, I would like to receive subscription renewal notices by e-mail

No, I do not wish to be contacted by e-mail.

FAX TO 1-847-437-6618 or
VISIT US ONLINE AT
www.powertransmission.com/subscribe.htm

THE SCIENCE FICTION ADDICTION

ERIK SCHMIDT,
ASSISTANT EDITOR

WHY SCI-FI MOVIES AREN'T AS FAR FROM REALITY AS YOU THINK

It seems preposterous in the whimsical, wireless world of today, but in 1977 cinema's greatest visioners came together and decided the pinnacle of robotic technology in the future would be a motorized trash can.

Boy that sure feels like a long, long time ago in a galaxy far, far away, doesn't it?

To be fair, R2-D2 has lingered on steadfastly through the decades as one of pop culture's greatest creations, but on a purely technological standpoint the loveable little hunk of junk is starting to look a little dated.

Check the specs:

Short, portly body frame; cruising speed like it's perpetually slogged down in bantha fodder; complete lack of peripheral vision or angular mobility; spunky, borderline reckless demeanor that often gets it into troublesome situations it's not equipped to get out of.

It's less a groundbreaking scientific achievement and more a mechanical version of Danny DeVito after an all-night binge at Paddy's Pub.

When "Star Wars" creator George Lucas dreamt up Artoo, it was meant to exist in an impossible world full of space magic and swords of blinding, colored light. But, incredibly, just over three decades later, the rough draft of his famed astromech droid actually exists in reality — at least in the most rudimentary sense. They're called Roombas and they clean the lint from under your couch. Not exactly what old Georgie boy had in mind.

It just goes to show you how fast times can change. Like a streamlined vessel hurtling through the stars (the *Millennium Falcon*, perhaps?) we constantly push forward, not by small increments, but by leaps and bounds.

One of the easiest barometers of technological growth is, of course, the cell phone. We've gone from brick-sized behemoths to razor-thin flips to all-in-one smart phones in the time it took for pastels and crotch-sagging parachute pants to go out of fashion and then (tragically) come back in again.

Now that's progress.

But if you want another example of how far we've come, then why not look at the silver screen? Movies, oftentimes, are the litmus test for mankind's imagination, anyways. They show us what *might* be possible one day, if we just think hard enough.

Go back and look at some of the great sci-fi flicks of yesteryear — "Star Wars," "2001: A Space Odyssey," "Metropolis" — and you'll see "futuristic" technologies and ideologies that are rampantly available in present culture.

Dig a bit deeper into cinematic history (to the two-colored time of 1902, to be precise) and you'll find a quaint, little French film called "Le Voyage dans la Lune" about a band of astronomers who fly a rocket-propelled capsule to the Moon. The plot of the film was deemed sensationalized nonsense back then, but just over 50 years later two lads named Neil

and Buzz proved the "cosmic fantasy" to be wholly prophetic.

A much more recent film called "Serenity" (the move adaptation of FOX's cult hit "Firefly" series, directed by Joss Whedon of "Avengers" fame, for those of you who have never heard of the marginally released 2005 flick) had one of the most hilariously obvious gadgetry precog-

nitions. In it, the main character watches video footage in perfect clarity on a handheld, square-shaped waif. Five years later — yup, you guessed it — Apple gave us the iPad.

So while it took half a century for technology to catch up to the boundless genius of George Méliès, it took only *half a decade* to outpace the man who once gave stage directions to the Incredible Hulk.

The summation of these remarkable findings is thusly: We live in a world where imagination has crashed head on into practicality and exploded into thousands of remarkable technological achievements. The 1970s dreamt of a tech savvy time of fully automated robotic interfaces and near-sentient A.I.

Folks, we're living in it.

Over in the land of gears — where "PTE" has a permanent timeshare — there is a recent technology called random bin picking in which robots can scoop and sort loosely placed objects within a container. These robots are not remote-controlled by a human, mind you; the robots actually *see* the items with advanced sensors and adjust to their locations on the fly.

Decades ago, movie critics would have scoffed at such a fanciful idea and plunged both their thumbs to the ground in a seething act of disapproval. Today, such robots are living, breathing pieces of society's everyday operations.

And if cinema really is a blueprint for the world of tomorrow, just think about the marvelous muses our future selves have access to: "Avatar," "Inception," "District 9" — heck, if we get even *one* outrageous gizmo from the Marvel franchise we can all die with Thor-sized smiles on our faces.

We have caught up to the movies of yesteryear, make no bones about it. The only question is: When will we catch up to the movies of today? **PTE**





Less is more.

Are you under pressure to reduce costs? We can help! The **MOVIGEAR**[®] Mechatronic Drive System from SEW-EURODRIVE substantially reduces your inventory with its ability to cover a broad range of gear ratios with a single unit. In addition, independent research has proven that **MOVIGEAR**[®] reduces start-up and operating costs by 20-30%. So, relax...we got this!



SCHAEFFLER



X-life Bearings for Gearboxes

**More capacity.
More rigidity.
Less friction.
Less downtime.**



X-life products from Schaeffler feature optimized roller geometries and raceway finishes that are so precise, their service life far exceeds the conventional standard — as much as 70% in the case of our cylindrical and spherical roller bearings.

Bottom line:

Maximum efficiency for your gearboxes.

Only X-life. Only from Schaeffler.

Need more details?
Please contact us at 803-396-3644 or
ads.ind@schaeffler.com
www.schaeffler.us

Superior-quality products.
Comprehensive reliable solutions.

