

Power Transmission Engineering®

DECEMBER 2020

BUYER'S GUIDE

LINEAR MOTION

AEROSPACE



Power Transmission Engineering is
now published by The American
Gear Manufacturers Association



You could always rely on your brother for the best protection.

You still can. With Brother Gearmotor's industry-best 5-year limited warranty, you can be assured of the best protection and performance on every standard model.

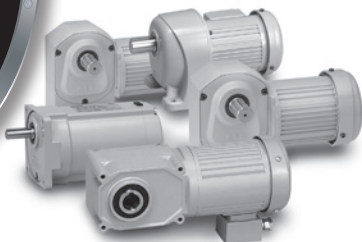

With premium protection comes the ultimate peace of mind. That's why Brother leads the way once again, by shielding its entire line of standard gearmotors with the industry's best warranty. No matter how far the journey or how rough the path, rest assured you've got the protection you need right at your side. Brother...we've got your back.

Call us today for a sample gearmotor to try out.

brother
at your side

866.523.6283
BrotherGearmotors.com

Power Transmission Engineering®

DECEMBER 2020

PAGE 34
OUR 2020
BUYER'S GUIDE



A Publication of
The American Gear
Manufacturers Association

FEATURE ARTICLES

[20] **Bosch Rexroth Celebrates 30 Years of Linear Motion Innovations**

PTE's Senior Editor Matt Jaster catches up with Richard Vaughn, automation engineering manager at Bosch Rexroth, to discuss advancements in linear motion today.

[22] **Leveraging Stepper Motor Linear Actuator Configurability**

Understanding the unique capabilities and limitations of each type of SMLA makes it easier to maximize their wide range of flexibility.

[26] **An Aerospace Action Plan**

Three trends to consider heading into 2021.

TECHNICAL ARTICLES

[70] **Efficiency and Heat Balance Calculation of Worm Gears**

*An automatic simulation method is presented for analyzing the efficiency and heat balance of various design of worm gears as developed and integrated in *WTplus*.*

[78] **Rolling Bearing Performance Rating Parameters Review and Engineering Assessment**

A critical review of key rating parameters for predicting rolling bearing performance — discussing their origin, definitions and significance in terms of fatigue life of the bearing; and to clarify their limitations and applicability in bearing selection and machine design.

Stay Connected



Follow us on Twitter
twitter.com/#!/PowerTransMag



Connect with us on LinkedIn
www.linkedin.com/groups/Power-Transmission-Engineering-PTE-2950055



Subscribe Online
www.powertransmission.com/subscribe.htm

Vol. 14, No. 8. POWER TRANSMISSION ENGINEERING (ISSN 2331-2483) is published monthly except in January, May, July and November by The American Gear Manufacturers Association, 1840 Jarvis Ave., Elk Grove Village, IL 60007, (847) 437-6604. Cover price \$7.00. U.S.

Periodicals Postage Paid at Elk Grove Village IL and at additional mailing offices. Send address changes to POWER TRANSMISSION ENGINEERING, 1840 Jarvis Ave., Elk Grove Village, IL 60007.

The American Gear Manufacturers Association makes every effort to ensure that the processes described in POWER TRANSMISSION ENGINEERING conform to sound engineering practice. Neither the authors nor the publisher can be held responsible for injuries sustained while following the procedures described. Postmaster: Send address changes to POWER TRANSMISSION ENGINEERING, 1840 Jarvis Avenue, Elk Grove Village, IL, 60007. ©2020 Contents copyrighted by THE AMERICAN GEAR MANUFACTURERS ASSOCIATION. No part of this publication may be reproduced or transmitted in any form or by any means, electronic or mechanical, including photocopying, recording, or by any information storage and retrieval system, without permission in writing from the publisher. Contents of ads are subject to Publisher's approval.

BEYTA GEAR SERVICE PUTTING
A LIFETIME

OF

GEAR
DESIGN
EXPERIENCE

TO WORK FOR YOU

- Reverse engineering
- Gearbox upgrades
- Custom gearbox design
- Specification development
- Project management
- Vendor qualification
- Design reviews
- Bid evaluations
- Tooling design
- Customized gear training
- Equipment evaluation
- Custom machine design

Charles D. Schultz
chuck@beytagear.com
[630] 209-1652

www.beytagear.com

QuickSilver Controls SilverMax™ Integrated Hybrid Servos

Motor + Encoder + Controller + Driver

High Efficiency Over Wide Speed Range
 Highly Programmable
 Handles Large Inertia Mismatch
 NEMA 23 and 34

Bringing Our 23 years of
 Hybrid Servo Expertise
 to Your Project!



+1 909 599 6291

www.QuickSilverControls.com



Power Transmission Engineering

VOL. 14, NO. 8

[06] PTEExtras

Online information from **NSK**, **Lubrizol** and more.

[08] Publisher's Page

Last But Not Least

[08] Product News

SEW-EURODRIVE provides drive solution for Ilseemann Automation; **Heidenhain** upgrades modular angle encoder series; Isotech offers slew rings and turntable bearings for heavy-duty applications; **Forest City Gear** expands threaded wheel grinding capabilities; **Portescap** provides DC coreless motor for horticulture application.

[67] Engineering sMART

Products and services marketplace.

[90] Industry News

MHI hires vice president of sales; **SKF** and **Imperial College London** extend R&D partnership; **Bearing World** produces numerous highlights for **Klingelberg**.

[94] Advertiser Index

Contact information for every advertiser in this issue.

[95] Subscriptions

Renew your free subscription today.

[96] Power Play

Turning the Page on 2020

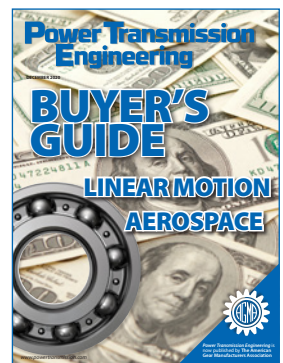



Merry

Christmas

From all of us at



Sumitomo Speed Reducer Attachments

The keyless Taper-Grip bushing system provides a simple and reliable shaft attachment for Sumitomo speed reducers and gearmotors. This system allows bi-directional shaft rotation and stop-start operation with a powerful, slip-free grip. Learn more here:

Sumitomo: How to Install a Taper Grip Bushing:

www.powertransmission.com/videos/Sumitomo:-How-to-Install-a-Taper-Grip-Bushing/

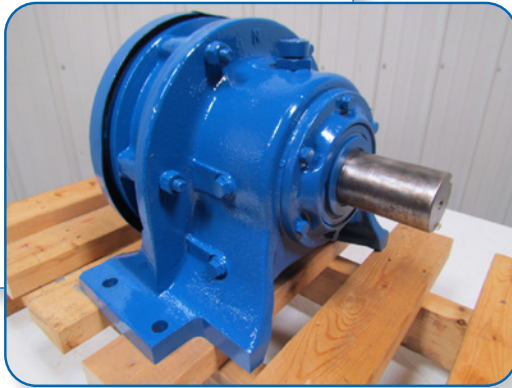

Editor's Choice:

2020 and Beyond with Bonfiglioli

What's a product launch look like during a pandemic? The Italian-based Bonfiglioli found out firsthand that new challenges create new opportunities. Learn more here:

www.powertransmission.com/blog/2020-and-beyond-with-bonfiglioli/



Editor's Choice:

Stainless Steel Powertrains Provide Peace of Mind

Coastal had used painted speed reducers from Boston Gear and other manufacturers for at least 20 years and decided to standardize on Boston's stainless steel units about 10 years ago. Learn more here:

www.powertransmission.com/blog/stainless-steel-powertrains-provide-peace-of-mind/



Power Transmission Engineering



AGMA MEDIA
1840 Jarvis Avenue
Elk Grove Village, IL 60007
Phone: (847) 437-6604
Fax: (847) 437-6618

EDITORIAL

Publisher & Editor-in-Chief
Randy Stott
stott@agma.org

Senior Editor
Jack McGuinn
m McGuinn@agma.org

Senior Editor
Matthew Jaster
jaster@agma.org

ART

Art Director
David Ropinski
ropinski@agma.org

ADVERTISING

Advertising Sales Manager & Associate Publisher
Dave Friedman
friedman@agma.org

China Sales Agent
Eric Wu
eric.wu@eastcotec.com

Materials Coordinator
Dorothy Fiandaca
fiandaca@agma.org

CIRCULATION

Circulation Manager
Carol Tratar
tratar@agma.org

ACCOUNTING

Luann Harrold
harrold@agma.org

MANAGEMENT

President
Matthew Croson
croson@agma.org

FOUNDER

Michael Goldstein founded Gear Technology in 1984 and Power Transmission Engineering in 2007, and he served as Publisher and Editor-in-Chief from 1984 through 2019. Michael continues working with both magazines in a consulting role and can be reached via e-mail at michael@geartechnology.com.

HARSH ENVIRONMENTS CALL FOR RESILIENCE & RELIABILITY.

SPHERICAL ROLLER BEARING SOLID BLOCK HOUSED UNITS.

RBI Bearing's steel housed units can endure challenging environmental conditions, such as, impacts from aggregate, extreme temperatures, heavy load conditions & misalignment to keep your operations running. **RBI's solid housed units are also available with Armor Bearing Technology & Protection to reduce bearing friction and substantially increase bearing life.**

- Steel, powder coated housing
- Field convertible; non-expansion to expansion (vice versa)
- Bearing insert pressed steel retainers
- Bearing rings & roller 52100 bearing steel
- Teflon labyrinth seal
- Concentric locking collar
- Bore sizes over 4" come with a double collar

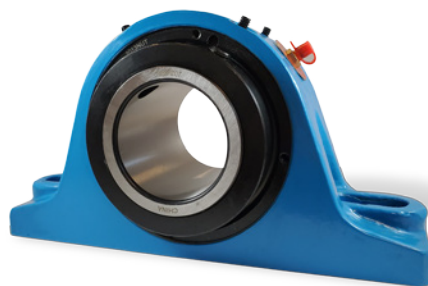

FOR PRICES, SIZES & AVAILABILITY CALL 1-800-708-2128.



RBI BEARING
Bearings + Technology + Solutions

Last But Not Least

Welcome to the last issue of the year for *Power Transmission Engineering*. It's been a tough slog for everyone, and we're glad you stuck through it with us.

Whether you read our articles at the office, on the factory floor, or (more than likely these days) at home, we're proud to give you a wide variety of high quality articles detailing the engineering and practical application of gears, bearings, motors, couplings and other components vital in keeping the world moving.

As we bring the year to a close, we're more committed than ever to bringing you the best possible coverage of mechanical power transmission components and technology, and we hope this issue demonstrates that commitment to you.

For starters, we present our annual Buyer's Guide in this issue (p. 34). We have more than 30 pages of listings by category of the leading suppliers of power transmission components and related products and services. Hopefully, business at your company is rebounding strongly, and over the next few months, you'll have a need to get in touch with some of these suppliers. Don't forget, though, that this printed Buyer's Guide is just the beginning. The categories you see here are broken down even further at *powertransmission.com*, so you can find exactly what you need. Plus, online many of the leading suppliers have provided us with in-depth information on their companies, and you can contact them right through the site.

In addition to the Buyer's Guide, this issue has a focus on linear motion, and we have articles from two of the industry leaders in that field to demonstrate some of the latest technologies. Senior Editor Matt Jaster sat down (remotely!) with Richard Vaughn, automation engineering manager at Bosch Rexroth, to discuss some of the latest innovations (p. 20). We also have a great how-to article from Thomson Industries and Motion Industries about configuring linear actuators (p. 22).

Matt Jaster also interviewed some leading suppliers in aerospace, and he presents some trends to consider heading into 2021 (p. 26).



Of course, we're also bringing you a strong technical lineup this issue, with an article from the FZG Research Institute on calculating efficiency and heat balance in worm gears (p. 70). We follow that up with an in-depth article from the experts at SKF that explores and analyzes the methodologies used in bearing performance rating.

Our mission at *PTE* is to provide you with the absolute highest-quality editorial and technical coverage of the power transmission industry. I'm proud of our team for delivering on that promise in the toughest of times and under far less than ideal circumstances. Altogether, it's a great issue that we're honored to present, and we hope you enjoy reading it.

Ending the year on a high note gives us something to build on. It provides us with encouragement and reassurance that not only can we endure, but we can thrive. We're excited about 2021, and we're looking forward to serving you with even more and better information next year.

On behalf of the staff at *Power Transmission Engineering*, AGMA Media and the American Gear Manufacturers Association, I'd like to wish all of you a healthy holiday season, a happy new year and sincere hopes for prosperity and opportunity in 2021.

FOR SPEED AND ACCURACY

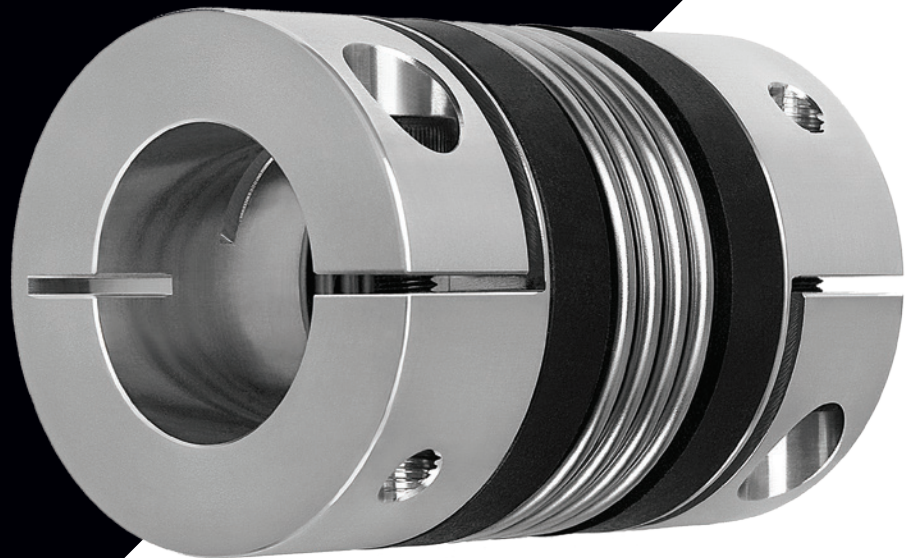

BELLOWS COUPLINGS

- ✓ Torsionally stiff
- ✓ Well balanced
- ✓ Low inertia

THE COUPLING.
RW-AMERICA.COM

R+W[®]
A POPPE + POTTHOFF COMPANY

SEW EURODRIVE

PROVIDES DRIVE SOLUTION FOR ILSEMANN AUTOMATION

Especially for gantry systems, rapidly accelerating heavy loads can shoot the electrical power demand of frequency drives through the roof. At the same time while braking, regenerative energy is being put back into the drive system. For Ilsemann Automation, the challenge was to make the most effective use of the braking energy and to not dissipate it in braking resistors. In its retrieval robots for plastic processors, the company uses a drive solution from SEW-EURODRIVE that thin-walled plastic cups are widely used in the food industry. Given the millions of pieces involved, the demands on the injection molding technology are incredibly high in terms of productivity, efficiency and availability. These requirements also apply to the retrieval technology that removes the finished plastic cups from the injection molding system. For this task, Ilsemann Automation uses an XYZ gantry with multi-axis-coordinated servo drives. An MDP92A-series central supply unit from SEW-EURODRIVE provides power to the gantry drives and other rotary, transfer, hinged and depositing axes in the DC link connection.

In a new development, the Bremen-based company integrates a double-layer capacitor for buffering the energy released in the power supply. The MOVI DPS-series storage unit from SEW-EURODRIVE is placed between the supply unit and the seven MOVIDRIVE drive frequency inverters. This construction has three key advantages — operational reliability, energy efficiency and the limitation of peak loads.

Energy concept creates advantage

Ilsemann Automation is a global provider of handling systems for injection molding technology. Its systems are used on every continent. With the new power supply system it has developed in collaboration with SEW-EURODRIVE the company has gained a real competitive edge. The system's key unique selling point is its robustness in terms of voltage fluctuations. Thanks



to the temporary storage, the systems can be used in countries with limited grid quality without any additional protective measures.

Compensating for supply fluctuations is so important because the retrieval system is at work in the immediate vicinity of the injection molding machines. In this, it must be ensured that the plastic cups are removed in exactly the correct time window to stack them on a conveyor belt. The limited time for this is linked to the production speed of the injection molding system. The retrieval must happen within a 0.7-second window. This speed can only be achieved with highly dynamic forward and backward movements. If supply fluctuations occurred, the risk of a collision between the tool and the handling unit would increase because the required movement ramps can no longer be realized. "We must ensure that our system will not collide with the expensive injection molding tools, even if there is a power failure," says Gerhard Kropp, design manager for electrical engineering at Ilsemann Automation.

Storage helps equalize

The robot kinematics experts from Bremen, Germany therefore got together with SEW-EURODRIVE in a joint engi-

neering project to find a way of achieving greater supply reliability. The development goal led to indirect supply of the multi-axis system from an EMF plate capacitor. This feeds the DC link of all the drives via its storage buffer with the requisite level of reliability and safely equalizes any potential supply fluctuations all the way to complete failure. The capacity of the unit is sized in such a way that the handling unit can safely complete the work cycle that has begun before the gantry shuts itself down in a controlled fashion. This eliminates any potential collisions with the open injection molding tool.

In addition to increased operational reliability, the unit integrated into the DC link connection also offers further benefits such as the increased energy efficiency and the reduction of load peaks. Both of these factors are directly linked to the fact that the energy currents in the gantry are harmonized, and above all retained. Especially in highly dynamic gantries, accelerations and decelerations happen successively within a short time frame. The capacitors in the Ilsemann Automation handling units collect the energy released by the motors while braking and make it available to the drives again when they accelerate. The capacitor module acts like a short-term battery with a



90 MISSILES

330 SAILORS

1,100 MILES OUT
TO SEA

**ZERO
ROOM
FOR GEAR
DRIVE
FAILURE.**



Whether it's the frontline combat fleet of the U.S. Navy or your own gear drive operation needs, Philadelphia Gear delivers mission-critical performance and reliable, responsive support.

With unmatched expertise that's on call 24/7, plus complete warranty coverage on workmanship and material for any gear drive we service, including those from other manufacturers, we've set the standard in dependability — on land and at sea — for more than 125 years.

Keep your mission moving.

Visit PhilaGear.com/MyMission to learn more.

booster function during acceleration. Ideally, this construction works so effectively that no kinetic energy needs be dissipated via braking resistors.

Measurements have shown that the energy solution was able to halve the gantry's energy consumption. Regenerative units which feed back into the power grid are much less suited to this application because they cannot reach anywhere near the same level of efficiency. A calculation example from Germany provides a further argument in favor of buffer storage—the current generated under braking is not fed cheaply back into the grid, only for the system to draw energy for acceleration from the local power supply company again at a much more expensive rate.

Load management lowers costs

Keeping the braking energy in temporary storage also has a positive effect on the grid usage fees and annual service costs end users pay to the local utilities company for its services. It should be considered that the cost of extraordinary load peaks can become enormous after just a few minutes, as the power supply costs are calculated annually. Measurements are taken over a 15-minute period. Here is a calculation example for a company with its own medium-voltage supply, over 2,500 hours of power usage a year, and costs of 120 euros per kW. If load peaks drive the planned usage up by 100 kW within the 15-minute period, this will lead to costs of 12,000 euros. Effectively smoothing out these load peaks is vitally important in the context of energy management.

This effect is supported by the slimmer design of the supply installation that can be achieved because the storage handles the peak loads



of the Ilseemann gantry. The supply infrastructure therefore only has to provide a more continuous power. In one of the first gantries configured with SEW-EURODRIVE, the peak load was cut from the 70 hp typical of such an application to just 8 hp. The cable cross sections were also cut accordingly—from 16 mm² to 2.5 mm². By removing the need for an uninterruptible power supply, saving space and making installation easier overall, this also cuts the installation costs. The total sum of the advantages of “Power and Energy Solutions” from SEW soon pay off and are prize-worthy in the truest sense. In 2019, the Germany's federal state of Baden-Württemberg presented the Bruchsal-based company with the Environmental Technology Award in the category of energy efficiency for its intelligent power and energy management system for industrial drives.

Numerous benefits

With its retrieval gantry, Ilseemann Automation shows how easily a storage-based DC link connection

can be implemented in a multi-axis-coordinated drive application. Since the braking energy remains in the system, achieving effective load management is also relatively straightforward. The advantages include lower input power, greater operational reliability during supply fluctuations and more efficient use of electrical energy overall.

www.ilseemann-automation.com
www.seweurodrive.com



Heidenhain

UPGRADES MODULAR ANGLE ENCODER SERIES

Heidenhain has announced several significant technical upgrades to the already successful ERA 4000 angle encoder series, thereby adding increased reliability and functionality upon a strong foundation. These bearing-less encoders are used heavily in machines in the metrology, machine tool, semiconductor and robotic industries and have been for decades. With these upgrades, the new ERA 4000 series stands alone in accuracy, ease of use and logistical flexibility, and is exactly mechanically compatible with past models.

ERA 4000 angle encoders consist of a steel drum at various diameters with the 20-, 40- or 80-micron graduation on the outer diameter, and a scanning unit that reads the graduation. As an incremental system, there are reference marks available as distance-coded or one per revolution.

The most powerful upgrade to these encoders is adding Heidenhain Signal Processing (HSP) to the scanning units. This feature is an added circuit where the LED is dynamically controlled, and where the scanning unit “learns” of the quality of signal coming back from the drum then adjusts the LED intensity on the very next signal period. HSP

operates in an analog way and actually increases the speed capabilities of the encoder system to 1 MHz scanning, a 285% increase.

HSP also powers through contaminations on the drum like fingerprints, dust and liquid droplets, all without amplifying electrical noise as other encoders which are more sensitive to those types of contaminations often do. The result

is improved reliability which results in less machine down time.

Two other upgrades to the scanning units are a status LED on the side of the scanning unit which provides unit status helpful during the mounting process, and the addition of a smaller M12 connector which saves space and is more robust.

www.heidenhain.us



TWO SPEED SPINDLE DRIVES

PLANETARY REDUCERS

Providing Quality Unique Gearboxes & Solutions
For Use On Industrial Machinery

ANDANTEX

 USA Inc.

andantex.com Phone: 877-966-9151
info@andantex.com 1705 Valley Road, Wanamassa NJ 07712

Isotech

OFFERS SLEW RINGS AND TURNTABLE BEARINGS FOR HEAVY-DUTY APPLICATIONS

The rugged ball-bearing and crossed roller slewing rings from Isotech are characterized by their large diameter and large bores with only a small cross-section. They were designed for axial, radial as well as combined axial and radial loads. New design concepts and improved manufacturing processes for the ball-bearing and crossed roller slewing rings, enable our customer's designers to implement completely new solution approaches.

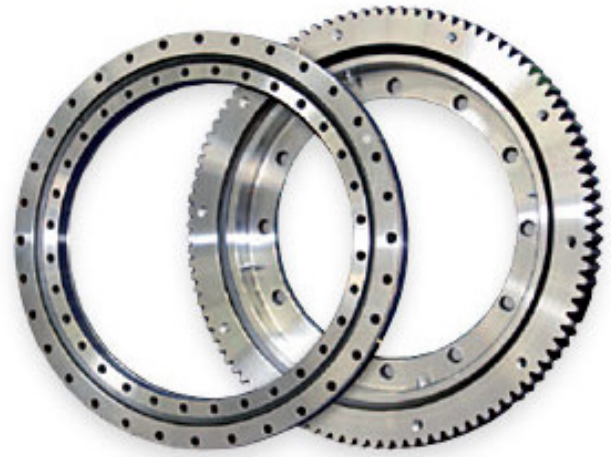

Highlights include a bore diameter starting at 50 mm, simple installation, available in various, individual versions, available with internal or external gear and without gear, corrosion-resistant types available on short notice and generally short delivery times.

Applications include agricultural machinery, conveyors, cranes and derricks, excavators, indexed, positional, and rotating tables, industrial robots, lifts, medical scanners and imagers, mining equipment, rotating displays, satellite and radar antennas, solar panels, textile looms, vehicle trailers, and wind and underwater turbines.

www.isotechinc.com



INDUSTRY READY

MOTORS, CONTROLS, AND GEAR REDUCERS

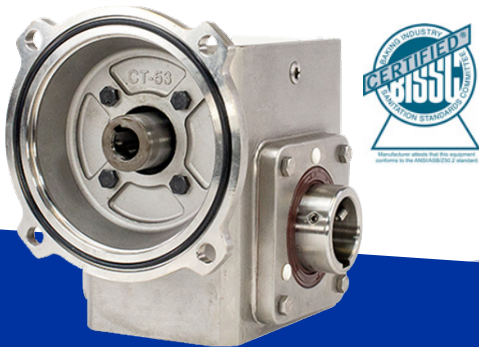

WorldWide Electric's SSHdR Series Stainless Steel Gear Reducers are now BISSC Certified! The SSHdR Series features IP69K Protection for close-range high pressure, high temperature spray downs and magnetic hardware for metal detection purposes. An affordable alternative to most major brands, the SSHdR Series comes backed with a 1 year warranty.

Superior Customer Support
Driven to provide the best possible customer experience

Proven Quality & Affordability
Premium motors, controls, & gear reducers at competitive prices

In Stock When You Need It
\$30M in inventory stocked at 6 regional warehouses

Same-Day Shipping Available
Most orders placed before 2PM local warehouse time can ship same-day.

Call us or visit us online!
(800) 808-2131 / worldwideelectric.net

WorldWide Electric Corporation | 3540 Winton Place, Rochester, NY 14623
Distribution Centers located in Allentown, PA | Atlanta, GA | Dallas, TX | Indianapolis, IN | Los Angeles, CA | Seattle, WA



What **if...**

one supplier provided IP69K products to meet your CIP standards?

SEALMASTER[®]

HUBCITY[®]



Sealmaster[®] PN Gold[™] Bearings

Sealmaster reduced maintenance PN Gold bearings feature a high phosphorus, electroless nickel coated steel insert and a patented, triple lip/multi-directional high performance seal. Specially engineered for industries with corrosive washdown environments such as food and beverage, pharmaceuticals and chemical processing, PN Gold mounted ball bearings provide outstanding performance.



Hub City[®] Stainless Steel HERA[®] Gear Drives

Bring energy efficiency and a sanitary drive package together with HubLoc[®] Keyless Bushing system, 90% efficiency, 316 stainless steel housings, and smooth polished cast surface finish.

Durable, corrosion resistant products that prevent downtime so you can focus on productivity and safely processing food every day!

regalbeloit.com/IP69K
Creating a better tomorrow[™] ...



Portescap

PROVIDES DC CORELESS MOTOR FOR HORTICULTURE APPLICATION

Pruning is the most manual and time-consuming job in the Viticulture and Horticulture industries. Light and powerful motorized pruning shears help reduce fatigue and repetitive motion injuries versus manual pruning tools. Motorized pruning shears are able to increase the speed and cutting force while maintaining an acceptable

user hand temperature, allowing the operator to complete a full workday.

A European provider of power hand tools needed a customized motion solution on a seasonal timeline for two battery-operated electronic pruning shear applications. The same motor/gearhead composite were able to be used for both applications. The smaller pruning shears were being designed



The Power of One²

Your Objective:

One face in perfect alignment with another. *For infinity.*

No problems. No distress. No delays.

That's the same objective you have for choosing your gear producer. Circle Gear's objective is to engage with every customer's objectives.

- ▶ One to 1000 gears
- ▶ Customer designed or reverse engineered
- ▶ Gearbox repair, rebuild or redesign
- ▶ OEM or end-users
- ▶ ISO 9001:2015 Certified

1501 S. 55th Court, Cicero, IL 60804
 (800) 637-9335
 (708) 652-1000 / Fax: (708) 652-1100
 sales@circlegear.com
 www.circlegear.com



Spiral and Straight Bevel Gears (*Cut, Ground or Lapped*) • Spur Gears • Helical Gears • Long Shafts • Herringbone Gears • Involute and Straight Sided Splines • Internal Gears • Worm and Worm Gears • Racks • Sprockets • ISO Certified



Partnering with QualityReducer to provide Gearbox repair, rebuilding and reverse-engineering.

for use in vineyards and smaller orchards. The larger shears were designed for larger parks and gardens.

Portescap was selected as the motion solutions provider based on its expertise in micro-technology, excellent product price-to-performance ratios, and ease of communication. Portescap engineers recommended the 30GT2R82 brush DC coreless motor with the R32 ball bearing mini motor gearhead. This motion solution is able to provide longer battery life thanks to its highly efficient and robust ironless design. In addition, the gearbox and motor commutation are able to withstand high peak torque. The total compact solution was able to allow for lighter hand tools with a longer product life, while also reducing fatigue for the end user.

www.portescap.com

NUM

LAUNCHES DIGITAL TWIN TECHNOLOGY

CNC specialist NUM has launched digital twin technology that enables machine tool manufacturers to reduce their time to market dramatically, by using powerful Industry 4.0 simulation techniques.

Originally known as pairing technology, and first used by NASA in the early days of space exploration, digital twin technology is now rapidly gaining industry acceptance as one of the most cost-effective means of accelerating the development of products, processes and services.

For automation products such as machine tools, a digital twin is a virtual model that uses simulation, real-time data acquisition/analysis and machine learning techniques to allow full evaluation of a machine's dynamic performance before constructing a physical prototype. The same technology can also be employed for customer presentations, virtual commissioning,



and operator training purposes — and all well before the actual machine itself has even been built.

NUM offers two versions of digital twin technology, to best suit customers' needs.

Both versions are designed for use with NUM's powerful, open-architecture Flexium+ CNC platform. One

version uses a naked Flexium+ controller and resident virtualization software running on the system's industrial PC to simulate the twinned machine automation. The other version uses the actual Flexium+ controller that will eventually be incorporated in the machine, linked via EtherCAT to a stand-alone PC running specialist high speed

MASTA 10

NEXT GENERATION CAE SOFTWARE FOR THE DESIGN, ANALYSIS AND OPTIMISATION OF TRANSMISSION SYSTEMS



DESIGN



ANALYSE



OPTIMISE

- Design gearbox and driveline systems from clean sheet or imported concepts
- Run and generate reports on a wide variety of analyses including static deflections, durability, efficiency, frequency domain NVH, time domain dynamics and more

Discover more at www.smartmt.com/masta

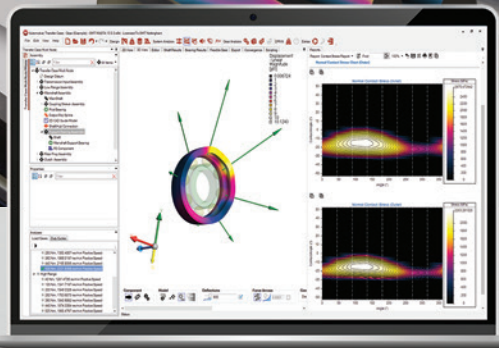

Globally integrated leader in mechanical transmission engineering services and software development
© 2020 Smart Manufacturing Technology

SMT

hardware simulation software to represent the mechatronics of the twinned machine.

The virtual controller version includes a software development kit for creating the software model of the machine. The model is a standalone PLC program that uses predefined components to simulate individual machine elements, such as sensors, spindles, pneumatic cylinders, etc. It is loaded into the integrated PLC of the Flexium+ controller.

The Flexium NCK in the controller executes the NC programs and simulates the changing position values of the machine's axes. To help users visualize the process, NUM's package includes the CODESYS Depictor software tool produced by CODESYS GmbH, which is used to produce 3D visualizations from the IEC 61131-3 code created by the simulation.

The other version of NUM's digital twin technology package accommodates real-time data acquisition

and analysis. It is based on the ISG-Virtuos hardware simulation software produced by Industrielle Steuerungstechnik GmbH (ISG). The Flexium+ controller that is intended to be used in the physical machine is connected via an EtherCAT network to a standard PC and interacts with the simulation software in real-time. The PC acts as the twinned virtual machine—with all simulated, virtual components behaving like real components in terms of their interfaces, parameters, and operating modes—to accurately replicate the structure and dynamic performance of the real machine. The movements of the machine are displayed realistically on the PC, using the supplied 3D simulation software.

NUM's new digital twin technology provides machine tool manufacturers with a very powerful and cost-effective means of reducing their development costs and accelerating their time to market. The virtual controller version is especially useful for the early development stage of a project, before the CNC system has been finalized, while the real-time hardware simulation version has the advantage that all sequencing (PLC) and motion control (CNC) programs that are created during development can simply be transferred to the real machine as soon as it becomes available.

www.num.com

PRECISION GEAR MANUFACTURING AND DESIGN ENGINEERING

Gear Units | Component Gearing | Design Engineering | Repairs & Rebuilds | Heat Treating

CINTI

MOTION + POWER TECHNOLOGY EXPO
SEPT. 14-16, 2021
ST. LOUIS, MO
BOOTH 2801

CINCINNATI GEARING SYSTEMS INC.
Manufactured Domestically, Trusted Internationally.™

513-527-8600 | www.cincinnati gearing systems.com | sales@cincinnati gear.com



C-B Gear & Machine

EXPANDS CAPABILITY WITH 5-AXIS MILLING

C-B Gear & Machine has expanded its precision milling capability with the addition of a new DMG MORI DMU 210P2 5-axis milling center.

The DMU 210P2 is one of a handful of five-axis milling machines in North America that can perform complex milling operations as well as mill gear teeth, making it state of the art machine technology. Reduction in set up and run times give C-B Gear a new capability for the high-speed production of any gear type on the market up to AGMA quality class 12 and higher. Cylindrical and right angle gearing up to 82" in diameter, soft or hard finished are possible.

Additionally, C-B Gear can now produce hard finished spiral bevel gears to either Gleason or Klingelnberg tooth forms. The DMU 210P2 adds to the company's wide range of large precision gear manufacturing, which complements C-B Gear's tooth grinding capability up to 4 meters in diameter. C-B Gear is one of the few gear manufacturing facilities in the

country with this type of capability in this size range.

"We're excited about the prospect of expanding into new markets with this type of capability" said C-B Gear General Manager, Frank Irely. "We've added all of the bells and whistles that help C-B Gear become even more competitive in the industry with on-board tooth inspection, tool offset compensation and automatic workpiece eccentric adjustments. Customers can expect higher quality and faster turn-around times than in the past".

Since 1952, third-generation family-owned C-B Gear has been providing a wide variety of industries with quality products at a competitive price. "Expertise in precision mechanical component production, gear manufacturing and aftermarket gearbox repair has established C-B Gear as a highly valued supplier to our customers," said Irely.

www.cbgear.com

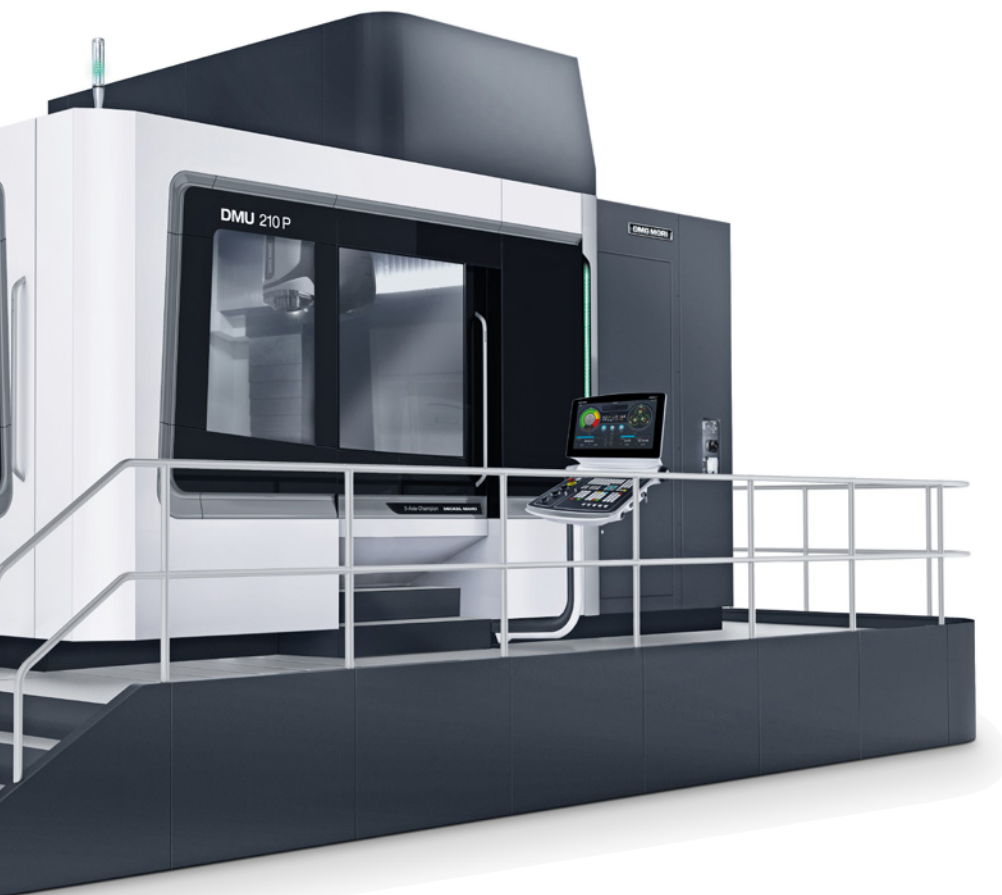

**PACKAGING
FOOD PROCESSING**

**Force Control Oil Shear
Clutches and Brakes are
Maintenance Free!**



**Lower Cost
Higher Production**



**FORCE CONTROL
INDUSTRIES, INC**

800-829-3244

WWW.FORCECONTROL.COM

RINGS | **DISCS**
4" - 144" OD | UP TO 60"

**EASY
DOES IT**

Service. Quality. Speed.

McInnes Rolled Rings believes in providing superior service and outstanding quality products, ensuring the entire sales process is as easy and as fast as possible for our customers.

When it's seamless, it's McInnes.

**McINNES
ROLLED RINGS**

1.877-736-4409
www.McInnesRolledRings.com/Easy

Forest City Gear

EXPANDS THREADED WHEEL GRINDING CAPABILITIES

Forest City Gear now can perform hard fine finishing of larger diameter cylindrical gears faster and more efficiently in higher volumes with the addition of a new Reishauer RZ 410 Threaded Wheel Grinding Machine.

The new Reishauer uses the threaded wheel (continuous generating) grinding process to combine very high metal removal rates and short idle times to produce gears as large as 500 mm in diameter and module 10 and shafts up to 700 mm in length much faster and more efficiently than profile grinding.

For smaller lot sizes, specialized, and prototype work the Reishauer

that allows the operator to change the clamping fixture at the same time the grinding wheel is being dressed on the opposite side of the column.

The capability of this machine to perform threaded wheel grinding, profile grinding, and polish grinding to create gears with 'mirror' finishes, along with the ability to control bias, allows it to fit perfectly within Forest City Gear's very diverse product requirements, according to Forest City Gear Technology Manager Gene Fann.

"The Reishauer adds speed and capacity for production of larger gears at lower cost per piece to our grinding



also gives Forest City Gear the ability to perform profile grinding using either CBN plated or dressable grinding wheels that can be modified on the machine with an on-board CNC dressing unit, working in conjunction with integrated inspection.

The unique architecture of the Reishauer also provides optimum speed and accessibility during wheel or workpiece changeover. The turret-mounted grinding spindle can be rotated between grinding position, dressing position and an easily accessible wheel-changing position

operation, with the versatility to accommodate a very wide variety of customer requirements, whether the high precision of a one-off master gear or ultra-quiet gears with mirror finishes produced in higher volumes," said Fann. "With quality and delivery standards never higher in all the industries we serve, this machine is a great addition."

www.forestcitygear.com

For Devices that require **RELIABILITY,** **HIGH-QUALITY & PRECISE PERFORMANCE**

Aerospace | Defense | Medical | Robotics | Commercial



SDP/SI is the Engineer's Preferred Source

Mechanical Components

Timing Belts & Pulleys
Precision Gearheads
Gears, Couplings and More

Precise Machining

Gears, Pulleys, Machined Components and Complex Assemblies are manufactured in our Hicksville, NY facility.

Engineering Development

Our engineers work closely with your design team, providing solutions to enhance performance, manufacturability and cost effectiveness. We look forward to working with you.

NEW 1,080 page METRIC catalog available

Request your free copy
Download 3D CAD Models
Shop 24/7

www.sdp-si.com

SDP/SI

STOCK DRIVE PRODUCTS/STERLING INSTRUMENT

250 Duffy Avenue, Hicksville, NY 11801 | 516.328.3300

Bosch Rexroth Celebrates 30 Years of Linear Motion Innovations

Matthew Jaster, Senior Editor

Bosch Rexroth began developing linear bushings, shafts, slides, and transfer tables as prototypes in the 1960s. The first two complete linear modules with linear guides in combination with a ball screw assembly and toothed belt drive as a ready-to-install subsystem were launched in 1990 — a quantum leap in the linear axes range which had previously been dominated by components. In 1996, they were followed by carriages with an integrated runner block. This in turn led to the introduction of the compact modules which offer high performance yet take up less space.

With the electromechanical cylinder (EMC), the company began electrifying actuators in 2007. These actuators replaced the conventional pneumatic solutions that had a higher energy consumption. In 2018, Bosch Rexroth presented the integrated measuring systems IMS, integrated into linear axes. The solution is largely immune to interference and offers high precision and integrability.

However, the products are not the only things that have changed over the last 30 years. The way the company works with users has changed too, for example through the introduction of CAD systems, 3D models, product configurators and modern eTools such as the selection and sizing tool LinSelect which was developed in 2016. This allows intuitive axis dimensioning and selection and guides engineers to the optimum linear axis with just a few mouse clicks.

PTE recently caught up with Richard Vaughn, automation engineering manager at Bosch Rexroth, to discuss advancements in linear motion today.

PTE: What are the key technologies in linear motion at Bosch Rexroth today?

Vaughn: The IMS compact measuring system and the Smart MechatroniX platform. With the integrated measuring system IMS-C, the measuring sensor is fully integrated in the runner block, which not only saves a lot of installation space but also reduces cost since there are no add-on parts. Smart MechatroniX is a mechatronics platform intended to serve as “Plug & Produce, Perform, & Proceed.” The three phases in this description all focus on simplicity and speed from development to the start of production; high operating performance and sustainability thanks to permanent updatability and a flexible use of components and modules. As a long-standing leading supplier and operator in linear motion technology, mechatronics, and factory automation, we know what the current and future production requirements are. Furthermore, the Bosch Group has its own sensor and IoT solutions, which we in-



For 30 years, Bosch Rexroth has been developing ready-to-install linear axes and has sold over a million axes during this period. (Image source: Bosch Rexroth AG)

tegrate in our new Smart MechatroniX products and system solutions.

PTE: How do engineers view electromechanical alternatives versus hydraulic or pneumatic equipment?

Vaughn: While all of the technologies have their purpose based on specific application requirements such as force, electromechanical solutions are often preferred when a choice can be made. A major benefit with electromechanical actuators is having complete control over the motion profile while at the same time offering cost savings due to only consuming power when work is being performed.

PTE: What are the greatest challenges in bringing digital linear motion technology to the factory floor?

Vaughn: Easy integration into machines and components from different manufacturers are often challenges. An example of this would be procuring a ball rail, linear scale, and control from different suppliers. This would most likely require connectivity and additional effort compared to products developed together such as our IMS-C integrated measuring system with our new ctrlX machine automation platform.

PTE: What are the benefits of linear motion product selection tools?

Vaughn: Readily available selection and sizing tools such as Bosch Rexroth's LinSelect allow “right sizing” for linear applications while at the same time providing outputs uti-

The Bosch Rexroth Smart Function Kit for Handling is a complete multi-axis material transport and handling solution for Cartesian systems.

lized in CAD configuration. This downloadable, easy to use sizing tool allows engineers to be self-sufficient during the selection process. By inputting your data for an application such as pressing a dowel pin into a plate, you get a properly sized Smart Function Kit for Pressing smart mechatronics solution complete with ordering parameters and CAD models in a matter of minutes.

PTE: How will linear motion technology evolve in the coming years?

Vaughn: With 30 years of linear axes experience, Bosch Rexroth is established as a technological leader. This linear axis innovation will continue by adding sensors, electronics, and software to components. In addition to the existing Smart Function Kit for Pressing, some examples in our Smart MechatroniX platform coming in the near future are the Smart Function Kit for Handling and the Smart Flex Effector.

PTE: What role will these technologies play in the factory of the future?

Vaughn: Completely new solutions such as Smart MechatroniX will pave the way to the Factory of the Future by having more intelligent, flexible, networked and software-based products. Simple and fast smart solution packages from a



single source is critical for the market. And, simple configuration and ordering using modern e-tools, fast and intuitive commissioning, and visual programming will play a vital role for future factories in the growing linear and robotic market.

PTE: How will service and maintenance change for linear motion components in the coming years?

Vaughn: As linear products such as the Smart Function Kit for Pressing continue to evolve within Industry 4.0, service needs will tend to be scheduled due to predictive maintenance monitoring as opposed to having a machine go down in production. IoT-capable, intelligent, and networked products will help future-proof through remote software updates while providing longevity and high overall equipment efficiency (OEE) of products and systems.

PTE: What should engineers' as well as programmers do today to better prepare themselves for the digital linear motion technologies of the future?

Vaughn: They should prepare for solution competence to meet agility as best-in-class linear components are paired with sensors, electronics, and software for completely new solution approaches. **PTE**

www.boschrexroth-us.com

The Bosch Rexroth Smart Flex Effector is a sensor-based compensation unit with independent kinematics in six degrees of motion. As sensitive as the human hand, yet as precise in transport and placement as a robot, the innovative, tactile technology reduces errors and saves time and costs in commissioning and during operation in many applications ranging from handling to joining processes.



Leveraging Stepper Motor Linear Actuator Configurability

Julian Anton, Thomson Industries, and Dave Buckley, Motion Industries

When designers and integrators need simple, flexible and compact linear actuation, they often turn to stepper motor linear actuators (SMLAs).

The high configurability of SMLAs is among their greatest virtues, but sorting through myriad configuration options to tailor the optimal solution for a particular application can be a challenge for even the most seasoned motion engineer. Understanding the unique capabilities and limitations of each type of SMLA will make it easier to take maximum advantage of their wide range of flexibility.

Why SMLAs?

Many factors make SMLAs desirable for linear actuation, with their high levels of customization and configurability being the biggest. Their efficient design enables configuration of countless motor, lead screw and lead nut options into a unique assembly for each application.

SMLAs are also popular because the stepper motor affords a basic level of control without requiring external feedback devices such as encoders. The designer can program a stepper motor to move to an exact position at various resolutions without requiring any feedback to a driver or controller. This can make the overall cost and complexity lower than servos, brushless DC and other motor options.

Stepper motors and lead screws are also naturally compatible, which contributes to the high configurability of the SMLA. This natural fit is evident when it comes to optimal speed ranges, load capacities and positional accuracies.

Additionally, lead screws and stepper motors offer many

available options for customization. Lead screws, for example, can be customized for end-machining, coating, accuracy, thread form and length, while stepper motors offer options to optimize motor windings for torque and speed, and to specify application-specific cabling, connectors, encoders, and end cap machining. Integrating stepper motors with lead screws dramatically increases the number of possible designs.

SMLA Types

Although the number of possible combinations is high, SMLAs are generally available in three distinct styles: rotating screw, rotating nut and telescoping. (Figure 1)

Each of the SMLA styles consists of the same general components: a stepper motor (1), lead screw (2), and lead nut (3), but as shown in Figures 2-4, the core mechanics differ based on the role of the nut.

Rotating Screw Structure and Mechanics

The rotating screw configuration, which is also known as a motorized lead screw, external linear, external nut or translating nut, allows for the most design flexibility and customization. As the name implies, actuation occurs when the lead screw rotates. When properly restrained to prevent it from rotating with the lead screw, the lead nut will translate across the threaded length of the lead screw.

Rotating Nut Structure and Mechanics

The rotating nut assembly has the most minimal and compact design of the three configurations. This design allows for the shortest retracted and overall length while having virtually no visible rotation of any of its components. Other names for this style of actuator are motorized lead nut, non-captive, internal nut and translating screw.

The mechanics of a rotating nut SMLA are essentially the inverse of the rotating screw configuration. When the motor is driven, the integrated lead nut within the motor shaft rotates and induces the lead screw attached to a load to translate in and out of the motor.

Telescoping Structure and Mechanics

Telescoping style actuators are intended to perform more like the traditional rod-style actuators found in most industrial applications, while still having the benefits of a configurable stepper motor and lead screw-based unit. At its core, the telescoping actuator is a rotating screw configuration with extra housing components that “capture” the lead nut within a spline and use an internal bushing to provide some side and moment load support. Because these configurations



Figure 1 The three types of SMLAs (left to right: rotating screw, rotating nut and telescoping) feature unique mechanics that make them ideal for varying applications (all images courtesy of Thomson Industries).

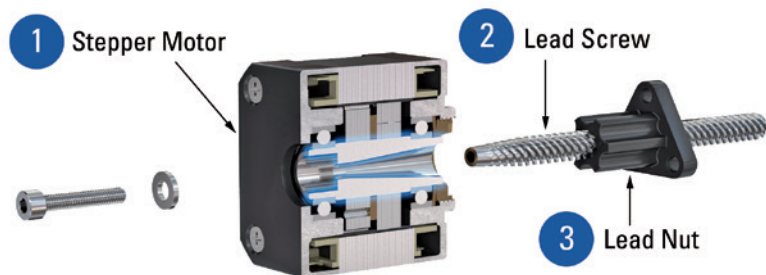

Figure 2 Cutaway view of a rotating screw configuration.

incorporate guidance and support directly into their design, in many cases, they won't need the external components that might otherwise be required. Other names for this style of actuator are motorized lead screw actuator, captive, electric rod and electric cylinder.

The mechanics of a telescoping SMLA are similar to those of a rotating screw configuration. The key difference is that its configuration integrates guidance and support components in the form of a splined cover tube and extension tube with a support bushing, which allows motion without the need for external components.

Installation

All three SMLA configurations have a similar installation process, which consists mainly of mounting the motor, supporting the lead screw if needed and attaching the load. The key differences lie in where the load attaches and how it is supported. (Figure 5)

For rotating screw configurations, the load attaches to the lead nut, and the end of the lead screw will need to be supported with a bearing or bushing for longer lengths. For rotating nut configurations, the load is attached to the lead screw. And for the telescoping configuration, the load will be attached to the end-mounting on the extension tube.

Both rotating screw and nut configurations are meant to withstand axial loads only, so guidance and support in the form of linear bearings and guide rails will be required for proper function. Since guidance and support are typically integrated into telescoping actuators, the need for linear bearings and guide rails can be eliminated in many scenarios.

Sizing for Applications

The SMLA's high levels of customization and configurability lend it to countless application possibilities. Figure 6 shows a few common examples of SMLA applications.

Sizing an SMLA for a specific application then, mainly involves understanding the motor, lead screw and lead nut limitations. Each of these core components must be sized appropriately to ensure proper functionality and optimal life. Luckily, most manufacturers provide theoretical performance plots that consider these components, making it much easier to size an actuator quickly. These plots will usually take the form of a speed vs. load curve, and highlight the optimal performance range of the motor, screw and nut combination.

Comparing SMLAs

SMLAs enable a modular motion system design approach that allows engineers to achieve a so-

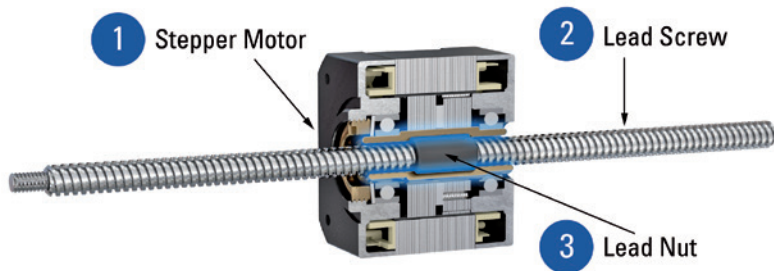

Figure 3: Cutaway view of a rotating nut configuration.

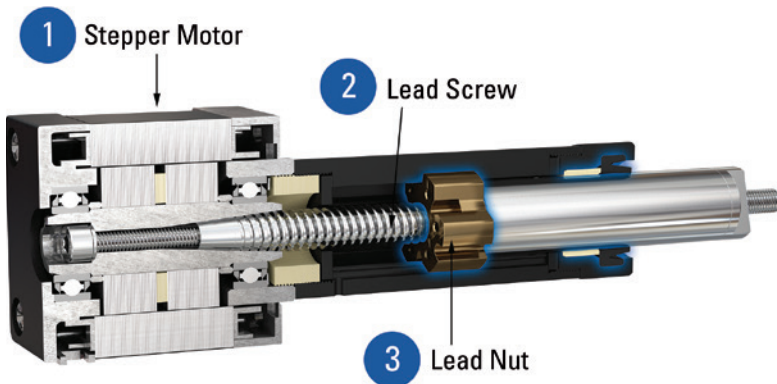

Figure 4 Cutaway view of a telescoping style configuration.

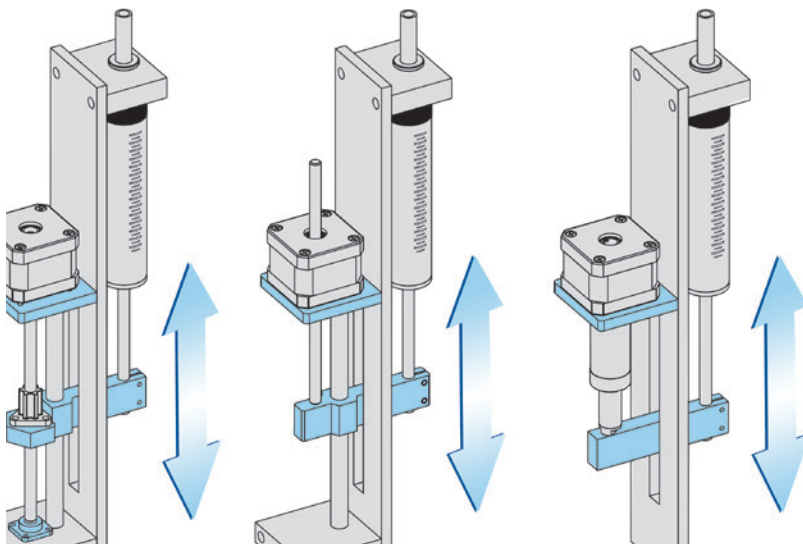

Figure 5 This fluid pump application example illustrates the typical mounting configurations for all three SMLAs (left to right: rotating screw, rotating nut, telescoping).

lution that is highly tailored to their specific application requirements. Determining which of the three SMLAs is best depends on many application-driven factors.

Those seeking maximum customization or a truly unique combination of components should consider rotating screw actuators. Rotating screw designs are the most commonly deployed type of SMLA, so many engineers will already be quite familiar with them.

Applications that would benefit from a more compact, simpler actuator and that do not require an anti-backlash nut or many encoder options might be better served by rotating nut designs.

Engineers who prefer to drop in a more traditional, rod-style actuator design and whose applications would benefit from integrated guidance, support and built-in anti-rotation should consider the telescoping design. This configuration is also worth considering if reducing the overall component count is important because the integrated guidance/support components eliminate the need to purchase external ones. Table 1 summarizes the most

common strengths and weaknesses of each SMLA configuration, as well as a few common application examples.

To help designers and integrators wade through the many options, SMLA manufacturers are increasingly offering online tools to help them quickly and easily configure solutions for their applications. For example, there are online selector tools that allow users to identify the right SMLA for their application in a matter of minutes, while immediately accessing performance characteristics, 3D models, pricing and lead time.

Applying automated selection tools in the context of an understanding of the design, mechanics, installation and sizing of the three main SMLA types can help guide motion designers and integrators to the optimal choice for their applications. **PTE**

For more information:

Visit MotionIndustries.com/PTE or find your linear solution here (tinyurl.com/y3gq7o6m).

Julian Anton, design engineer at Thomson Industries, Inc., is responsible for new product design and development for lead screws and stepper motor linear actuators. He earned his Bachelor of Science in Mechanical Engineering from San José State University. Julian has been with Thomson for 7 years.

Dave Buckley is an industrial automation manager at Motion Industries, with a focus on automation and linear. He has 55 years of experience in industrial design, specializing in fluid power before moving onto automation design in 1985. Initially spending 17 years in design engineering in the steel industry at Dofasco and Stelco (later US Steel), Buckley then moved to technical sales and became the Canadian Director of Marketing and Sales for the Bosch organization (then called Basic Technologies). He later moved on to be the Canadian Manager for THK America before landing at Motion Industries.

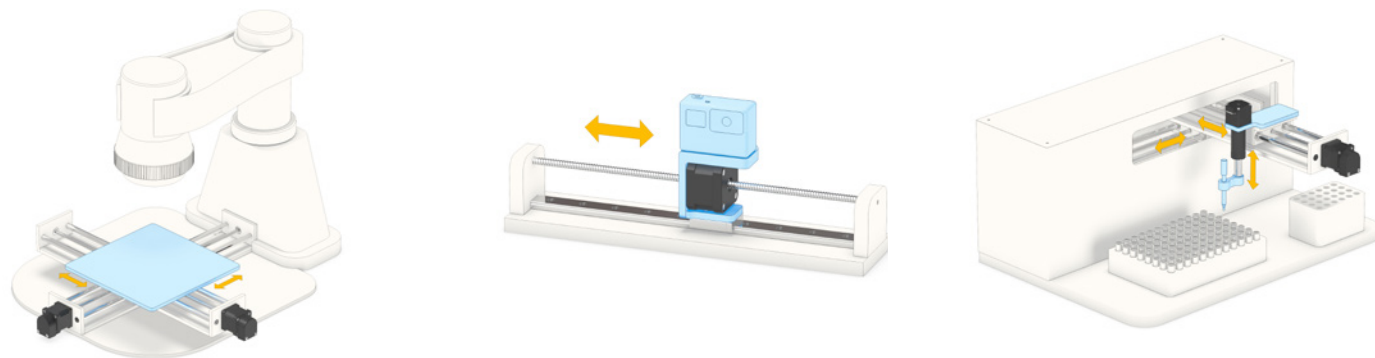

Figure 6 By reducing the total number of components needed, SMLAs are ideal for a wide variety of space-conscious applications, including (left to right): XY stage (rotating screws), horizontal positioning (rotating nut), and fluid pipetting (telescoping and rotating screw).

Table 1 SMLA configuration comparison.

Configuration	Strengths	Weaknesses	Application Examples
Rotating screw	<ul style="list-style-type: none"> Highly configurable Anti-backlash nuts available Easy-to-install encoders on the back of the motor Polytetrafluoroethylene (PTFE) coating of lead screw available Easy to maintain 	<ul style="list-style-type: none"> Lead nut more exposed to the elements Slightly more involved assembly process due to more mounting components The lead screw needs to be supported for longer lengths 	<ul style="list-style-type: none"> Pipetting Fluid Pumps XY Stages 3D Printing Life Sciences Rubber and Plastics
Rotating nut	<ul style="list-style-type: none"> Simple, compact design Simple mechanics Shortest overall length No visible rotation of components 	<ul style="list-style-type: none"> Rear protruding lead screw Less encoder options If available, less robust anti-backlash designs 	<ul style="list-style-type: none"> Fluid Pumps Horizontal Positioning Robotic Gripper Aerospace
Telescoping	<ul style="list-style-type: none"> Integrated guidance and support Built-in anti-rotation Easy-to-install encoders on the back of the motor Usually has some level of environmental protection Simple mechanics No visible rotation of components 	<ul style="list-style-type: none"> Higher cost Stroke limitations Fewer customization options Longer collapsed length vs. the other configurations 	<ul style="list-style-type: none"> Pipetting Plate Vertical Positioning Monitor Tilting

Quality Bearings & Components (QBC)

Quality, Performance, and Value

Quality Bearings & Components (QBC) specializes in bearings and bearing related products and services.

With quick global sourcing, comprehensive bearing services, customization, and competitive pricing we surpass customer expectations for quality and service.

As an authorized stocking distributor for many of the world's most recognized bearings and linear motion products manufacturers we have access to a wide variety of components, including Thomson's Super Smart Ball Bushing™ Bearings & Pillow Blocks, ball bearings, pressbearings, sleeve bearings, thrust bearings, spherical bearings, rod ends, and much more. Technical information and product specifications are easily found at: www.qbcbearings.com.

QBC not only supplies bearings, but also the tools to ensure years of service and peak performance. For more than 10 years we have



been a BEGA Special Tools distributor. BEGA manufactures a wide range of specialized, high-quality tools for safe and economical solutions for mounting and dismounting of bearings and transmission parts. Select from Fitting Tools, Induction Heaters, Mechanical and Hydraulic Pullers, and Condition and Monitoring Tools.

When it comes to bearings, QBC has the products, expert knowledge and specialized services to provide you the best possible solution for your applications. We look forward to working with you!



FOR MORE INFORMATION

250 Duffy Avenue, Hicksville, New York 11801

Phone: 516-616-0436

Toll Free: 888-276-4787

Fax: 516-616-0443

Email: qbcsupport@qbcbearings.com

www.qbcbearings.com

Power Transmission Engineering

Free Knowledge Served Daily

For even more great information on linear motion, including technical articles, features and insight from the leading manufacturers, case studies and application examples, visit the *Power Transmission Engineering* archive.

www.powertransmission.com/subjects/linear_motion/

But don't stop there! Just type what you're looking for into our search box at the top-right of any page, and you'll find just as much great information from our archives on virtually any topic related to mechanical power transmission and motion control, whether it's gears, bearings, motors, clutches, chain, gearboxes and more.

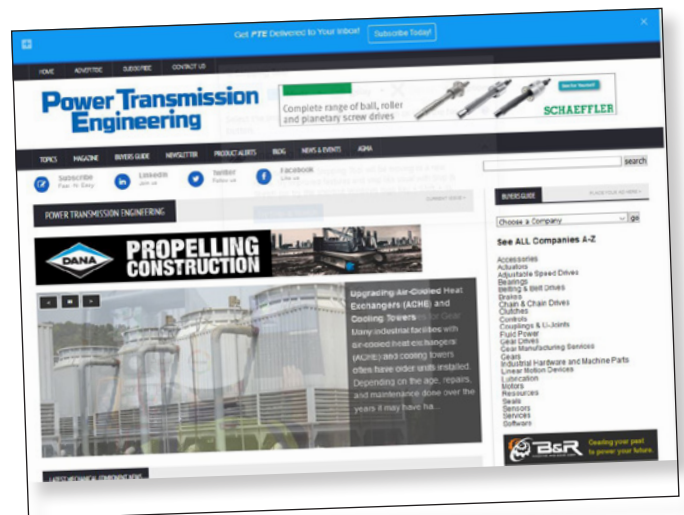

Power Transmission Engineering

FOR MORE INFORMATION

1840 Jarvis Avenue, Elk Grove Village, IL 60007

Phone: 847-437-6604

Fax: 847-437-6618

Email: publisher@powertransmission.com

www.powertransmission.com

An Aerospace Action Plan

Three Trends to Consider Heading into 2021

Matthew Jaster, Senior Editor

For many trade publication editors, October and November 2020 shall forever be known as the “Virtual Conference Months” as companies provided a slew of informative and educational virtual presentations in order to make-up for the lack of a trade show schedule.

Aerospace was a hot topic in many of the presentations, a market that in some areas suffered greatly due to the pandemic (I’m looking at you international and domestic commercial airlines), but managed to stay the course in other areas (military applications, drones and space exploration).

Three of the trends we’re seeing in aerospace/defense applications include the need for more complex and compact components, the ability of software tools to reduce aircraft assembly costs, and the not quite as negative drone and UAV market forecasts — with caveats. Here’s what we’ve learned from multiple sources in the aerospace community:

1. Component Complexity

In one presentation from Teal Group examining the aerospace/defense outlook moving forward it became obvious the need for more compact/complex components in aerospace applications. When Maxon Motors, for example, sends its products into orbit via a Mars rovers or a SpaceX cargo capsule, this technology becomes so much more valuable for similar high quality aerospace projects back on Earth. A motor that can handle the environments on Mars can be equally valuable in a commercial airliner flying at 35,000 feet.

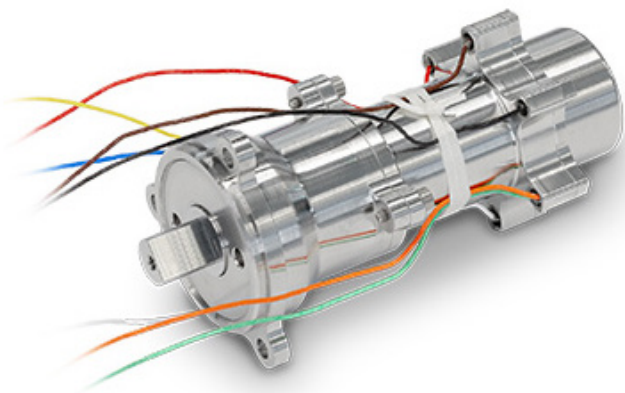

The Maxon EC20 flat combined with a GP 22 HD planetary gearhead is being utilized for mission-critical tasks on the Mars 2020 rover, Perseverance.

Maxon offers compact design, wide temperature range, capabilities, long service life, flexible configurations as well as high quality in its motors, gearheads, sensors, encoders, and controllers used in aerospace applications.

Maxon’s drives are used in complex flight systems, like autopilot systems that control flight altitude using mechanical control surfaces. They are also used in auto-throttle systems



Maxon EC32 motors have been equipped with low-temperature Hall sensors in aerospace applications.

and force feedback joystick or fly-by-wire flight control systems. In meeting the strict requirements of the aviation industry, Maxon motor developed a production method that electronically records the data of each product automatically during the manufacturing process. This ensures even the highest requirements can be met.

Maxon motors have also found use in passenger planes, where a single aircraft can require up to several hundred small drives. Many of these drives are used in the cabin itself, where they ensure comfort for passengers and crew members. DC motors and gearheads can be found in the in-flight entertainment systems (IFE), environmental control systems (ECS), and window shades. They also allow for seat positioning at the press of a button, as well as adjusting cushion hardness. An ECS system requires 48 Maxon DC motors for cabin ventilation, cooling the electronics, and closing and opening the air inlet on the outside of the aircraft.

Reliable components are critical to unmanned vehicles, whether aerial or ground. These components and vehicles often face harsh conditions and must withstand shocks and vibrations without issue. The drives must also be energy-efficient in order to allow for long periods of operation. Maxon DC motors meet all of these requirements and automated production lines help maintain the high-quality standards that these applications demand.

www.powertransmission.com/articles/0918/Motor_Insight:_Anatomy_of_a_Drone/

In 2012, SpaceX launched the first private cargo capsule to the international space station. On board were ten Maxon motor brushless DC motors to fulfill mission critical

functions. EC 40 drives kept the two solar panels facing the sun at all times, ensuring adequate power supply. By 2015, more than 60 Maxon brushless DC motors had participated in many SpaceX Dragon flights without a single failure.

www.powertransmission.com/issues/0920/Motors-in-Space.pdf

Within NASA's Mars rover, Opportunity, you will find more than 30 Maxon DC motors, specifically optimized for use in the 8 mbar of CO₂ Martian atmosphere. More than 11 years and 42 kilometers later, the drives are still performing as intended. The knowledge Maxon Motor gains from these missions furthers the benefits they can provide customers on Earth.

www.maxon.com

Meggitt Enhances Aerospace Portfolio

Electric motor design for aerospace applications includes considerations such as speed, torque, duty cycle, weight, volume, lifespan, thermal, efficiency, control, power source and more. Brushless DC motors are often used in these applications due to their high torque, high efficiency, low heat dissipation and extended life capabilities. However, AC induction, BDC, and stepper motors are also suitable for aerospace applications.

Meggitt PLC, headquartered in the U.K., produces a high-power density using high performance materials and the latest design and construction. This allows the company's



Meggitt has upgraded its service and support capabilities in China.

brushless motors to provide low wear and low maintenance. Since 1948, Meggitt has specialized in motors, power electronics and sensors for extreme environments. They offer an extensive range of electric motors intended to fit on-board aerospace, defense, and other extreme applications.

Meggitt PLC recently secured a three-year contract with leading China-based operator Shandong Airlines for the supply of maintenance and repair services of the Boeing 737NG. The SMARTSupport contract will be supplied out of Meggitt's Services and Support regional center of excellence in Singapore. This is the first SMARTSupport LTA Meggitt has completed in China

"We believe this order for our SMARTSupport flexible



DISCOVER MORE



A New Way to Buy Gearboxes, Bonfiglioli e-commerce



Follow Us on Social Media to Learn More:



aftermarket care package will be the first of many with our Chinese customers. Asia Pacific is a very important region for us, this contract will be supplied from our Singapore facility while we establish our base in China,” said Adrian Bunn, senior vice president, general manager for Meggitt’s service and support division.

At 42,000 square feet, the facility has doubled in size to incorporate fire detectors, cable assemblies, actuators, sensors, valves, and heat exchangers, adding several new capabilities to the current portfolio.

Meggitt’s Services & Support division established its site at Seletar Aerospace Park, Singapore, in 2012, and this latest expansion was driven by the significant growth in content Meggitt has secured on next generation aircraft platforms including the A350XWB, A320neo, Boeing 737MAX and both

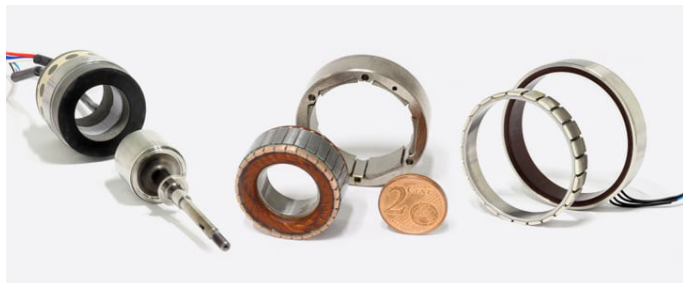

Electric motor design for aerospace applications includes considerations such as speed, torque, duty cycle, weight, volume, lifespan, thermal, efficiency, control, power source and more.

GTF and Leap engines.

“Our Singapore team has continued to work hard throughout the coronavirus pandemic to ensure we reach this important milestone. In spite of the recent crisis, long-term growth prospects in the Asian region remain strong. With our enhanced portfolio we are better equipped than ever to support our regional customers once the green shoots of recovery emerge,” said Bunn

www.meggitt.com

2. Software Tool Advancements Critical to Long-Term Success

Cloud computing. It’s everywhere in automotive, aerospace, trucking, rail, shipping and public transportation systems. Improving safety, security and the overall design of transportation components/systems is essential to long-term success—with or without a pandemic to challenge daily routines and disrupt business plans. Companies are paying much more attention to simulation software in order to push technology farther and faster in the extremely competitive aerospace market.

According to Siemens, getting an aircraft certified, whether new or modified, is a long, expensive, and bureaucratic process, albeit one that has led to the safest mode of transportation. From the largest aircraft in history to small two-seaters made of steel and fabric, every plane needs to prove airworthiness and compliance and be certified by regulatory

helical speed reducers 🔍

Did you mean: **DieQua Corporation?**

The search is over!

DieQua’s Inline Helical Speed Reducers offer an extremely compact design providing highly reliable space-saving performance for the most demanding applications. Look no further than DieQua.

- 14 sizes, 1-75 HP
- Multi-stage Ratios
- NEMA, IEC, or Servo Motor Adapters
- High Efficiency & Low Backlash
- Multiple Mounting Configurations

To finally find what you’re looking for, check us out on the web, or give us a call.



diequa.com/pte 800-280-5402

DIEQUA
Corporation



TLG Aerospace has helped numerous customers receive FAA certification in the U.S. at a low cost and in a short time, something they have achieved with impressive efficiency.

authorities before operation.

In 2019, TLG Aerospace, Seattle, Washington, used a Siemens Digital Industries Software solution for faster, cost-effective certification by analysis.

“What has changed is the balance between how much analysis you can do and how much you can use in the certification process,” said Robert Lind, director of engineering, FAA flight analyst designated engineering representative (DER), FAA flutter DER, TLG Aerospace. “This is a really exciting development in my 30 years in the industry. As CFD codes and computers have become more capable, we can certify faster and cheaper.”

Most of Lind’s work involves getting customers to type

certification with analysis. As one of TLG Aerospace’s four resident DERs, he can sign for certain certification functions on behalf of the FAA. TLG Aerospace uses *Simcenter STAR-CCM+* software from Siemens Digital Industries Software for CFD analysis and *MSC Nastran* software for FEA to develop full-vehicle certification models for loads, flutter and handling qualities, modeled appropriately for the entire flight envelope.

“We utilize *Simcenter STAR-CCM+* in a certification environment which is different from design. There is a great role for CFD in the certification process. We don’t use CFD to get an answer that the FAA signs off on. We use CFD to build a full-scale aero/structure/controls model so we can simulate vehicle response and produce loading and handling information,” said Andrew McComas, engineering manager and aerodynamicist, TLG Aerospace.

To certify a new aircraft, an aerodynamic database is required. To build the entire analysis database would require data for hundreds of thousands of conditions to be available in a short amount of time. The aerodynamic properties of the vehicle are calculated at design and at flight envelope extremes using CFD. The CFD results are mapped to a reduced-order aerodynamic model within the aeroelastic process. TLG Aerospace calibrates the aeroelastic model to develop full-vehicle aeroelastic solutions that are underpinned by the rigid CFD. The final aeroelastic model will reproduce full-vehicle integrated and distributed aerodynamics in rigid mode and yield a converged aeroelastic solution in seconds.



We answer EVERY CALL, EVERY TIME, within TWO RINGS.

It’s at the core of who we are.



REVISION	REV NAME	DATE
A	AK	09/12/2019

NES Bearing Company has been providing American-made custom bearing products and services to customers in diverse industries for over 22 years.

- ✓ NADCAP CHEMICAL PROCESSING
- ✓ AS9100 CERTIFIED
- ✓ ISO9001 CERTIFIED

NES Bearing Co., Inc.

nesbearings.com sales@nesbearings.com 877-870-3200

- Corrosion resistance
- Temperature extremes
- High fatigue life

- Short lead times
- Unique Materials
- Custom or Made to Print



The predictions are now in place to show regulations are met at certain conditions. Flight testing then validates the analysis models. This validation may be limited to something less than the full flight envelope to reduce risk for in-flight testing. Once validated, it can be used to show compliance at other flight conditions. Having a high-fidelity pre-flight test model significantly reduces the amount of required post-flight test model adjustments and calibrations.

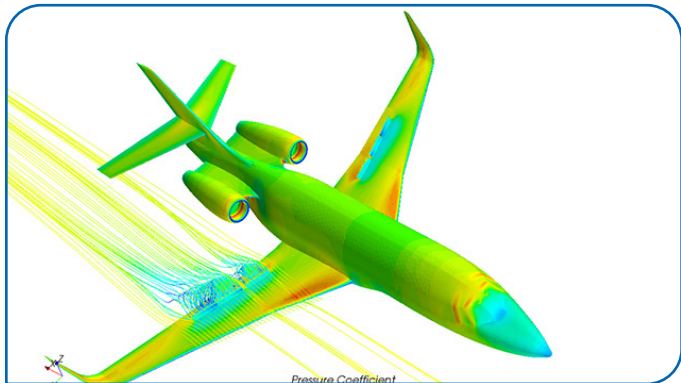

Having a high-fidelity pre-flight test model significantly reduces the amount of required post-flight test model adjustments and calibrations.

“Simcenter STAR-CCM+ runs robustly, accurately and repeatedly with simple processes and best practices,” says McComas. “That has given companies confidence that the code can be used as a source for aero database generation. Elastic computing from AWS, with Siemens’ power-on-demand licensing, helps run multiple simulations on multiple compute clusters simultaneously on the cloud in a secure way. If we did not have the POD licensing model, we wouldn’t have the capability to take full advantage of elastic computing resources and would incur the large cost of annual licenses.”

In short, the entire aero database is built in a shorter time with cost-effective licensing. Simcenter STAR-CCM+ is built from the ground up to enable innovation. In a recent blog, Siemens Digital discussed the need for engineers to have access to unlimited compute capacity, on-demand, in order to maximize their use of simulation data. If high performance computing resources won’t work, cloud computing is a viable alternative:

blogs.sw.siemens.com/simcenter/five-compelling-reasons-to-run-cfd-simulations-on-the-cloud/

TLG Aerospace has helped numerous customers receive FAA certification in the U.S. at a low cost and in a short time, something they have achieved with impressive efficiency. TLG Aerospace credits *Simcenter STAR-CCM+* combined with cloud computing for a significant reduction in certification costs.

Whoever said the future of engineering lies in computational fluid dynamic simulations in the cloud was clairvoyant — and apparently knew they’d be handling the workload from their home office in 2020.

www.sw.siemens.com

3. Drone Production Set to Triple in Next Decade

Drones were sort-of built for 2020. From Amazon dropping packages in suburbia to inspection drones monitoring an oil and gas facility, the unmanned aerial vehicle has plenty to offer in a world where people are being asked to stay away from others. Teal Group’s recent presentation on aerospace forecasts touched on some of these developments.

Civil Unmanned Aerial Systems (UAS) will be the most dynamic growth sector of the world aerospace industry this decade as commercial applications take off and civil governments adopt systems for new roles in border security and public safety.

“The pandemic is reshaping growth in the industry, boosting support for delivery drones while hurting investment in some longer-term applications,” said Philip Finnegan, Teal Group’s director of corporate analysis and author of the study. “On balance, the negatives appear to *slightly outweigh* the positives.”

The goodwill created by delivery of medical items by drone will help speed regulatory approval for wider deployment of drones and has encouraged companies to adopt UAS to do distance inspections of facilities. Yet the pandemic has sharply cut venture capital financing of drone companies, major aerospace companies are cutting investment in next generation systems, and the oil and gas sector is slashing capital spending.

Teal Group’s 2020/2021 World Civil UAS Market Profile and Forecast suggests that non-military UAS production will total \$108 billion in the next decade, soaring from \$5 billion worldwide in 2020 to \$18.4 billion in 2029, a 15.6% compound annual growth rate in constant dollars. The study includes annual forecasts of commercial, consumer and civil government systems and the individual submarkets. Teal Group, an independent aerospace and defense research and analysis company, has provided support for the FAA in the preparation of past annual commercial UAS forecasts.

Commercial use will drive the market as consumer drone



Drone: Civil Unmanned Aerial Systems (UAS) will be the most dynamic growth sector of the world aerospace industry this decade.

purchases slow and government purchases remain a small but growing portion of the market.

“A growing number of corporate clients are now moving from proof of concept work to deployment of fleets, helping to drive the commercial market,” said Finnegan. That is driving more than a 21% compound annual growth rate for commercial UAS production over the ten-year forecast. “The growing promise of the civil market is attracting the world’s leading technology companies, driving ever faster development of systems and business applications,” said Finnegan.

Delivery as a premium service promises to lead market growth in the United States, with the segment emerging as the leader by the end of the forecast period. Agriculture will be the leading sector overseas by 2029 thanks to heavy Chinese investment in subsidizing agricultural drone spraying.

Industrial inspection will emerge as a major commercial drone market over the next decade. Construction will be the largest segment of industrial inspection over the next decade, according to the Teal study. All 10 of the largest worldwide construction firms are deploying or experimenting with systems and will be able to quickly deploy fleets worldwide. Industrial inspection also includes other major segments such as energy, mining, and railroads, ranked in order of size over the next decade.

Other important commercial segments, ranked in order by ten-year size, include general photography, communications, insurance, and entertainment.

Civil governments are deploying an increasing number of unmanned systems. The United States and European governments have new pilot programs to deploy systems to protect land and sea borders. The United Nations and other peacekeepers are deploying systems to provide protection. Use by law enforcement, particularly in the United States, is soaring.

Firms in traditional aerospace, data analysis, semiconductors, telecommunications are all driving aggressively into serving this diverse civil market. Technology companies like Intel, Qualcomm, Microsoft, Apple as well as venture capitalists have poured more than \$2.8 billion into drone startups from 2012 to 2019, according to the Teal Group study.

US start-ups have received 65% of the funding over the period, enabling them to take the lead in development of drone analytics. Chinese firms, which have received 16% of the investment, are focusing on continuing their lead in hardware, moving from consumer to commercial systems. Europe is lagging at 9%.

It’s an industry worth keeping a close eye on post-pandemic. **PTE**

www.tealgroup.com



ustsubaki.com

YOUR **⚡** SIDEKICK FOR ROLLER CHAIN SOLUTIONS THAT OPTIMIZE OPERATIONS.

No matter how tough the challenge, our complete range of innovative roller chain products can help you keep your business running smoothly. That's what you can expect from your trusted, reliable sidekick.

A PERFECT USE FOR THE NEW...

SUPER STAINLESS™ CHAIN

- › Stainless steel chain with carbon steel strength
- › Up to 6x stronger than ordinary stainless chains





Want us to optimize your operations? That's what we do. Call us today to schedule an on-site visit 800-323-7790



LEADING THE MOVEMENT

©2019 U.S. Tsubaki Power Transmission, LLC. All Rights Reserved.

WE'RE

ALL IN

MOVING THE FUTURE.

3M Science.
Applied to Life.™

**ASH GEAR
AND SUPPLY**
INDUSTRIAL GEAR AND TOOL DISTRIBUTION

Best Gear (Media) Pvt. Ltd.

Blaser.
SWISSLUBE

BK BOURN
& KOCH

**BRELIE
GEAR**

CAPSTAN
ATLANTIC

CHAO CHIA GEAR
— 1983 —

Circle  Gear

CK POWER

Columbia Gear
Corporation
A SUBSIDIARY OF INDUSTRIAL MANUFACTURING COMPANY

Dontyne
Systems

DOPPLER
GEAR COMPANY

CDVS
TECHNOLOGY
AMERICA

EMAG

**ENGINEERED
ABRASIVES***

euro • tech

FOREST CITY GEAR

GEAR MOTIONS
Precision in Motion

GEARSolutions

Gleason

GREAT TAIWAN GEAR

GWJ
TECHNOLOGY

HELIOS
gear products

HOFFMANN
Hoffmann Filter Corporation • Your Partner in Filtration

IPM
Precision Machining
& Gear Cutting

KLINGELNBERG

LIEBHERR

LOUIS BELET
Swiss Cutting tools

MTB Machine Tool Builders
TOOLING • REPAIRS • SERVICE



MOTION+POWER TECHNOLOGY EXPO

SEPTEMBER 14-16, 2021

AMERICA'S CENTER CONVENTION COMPLEX
ST. LOUIS, MO



American
Gear Manufacturers
Association

gear
TECHNOLOGY

**Power Transmission
Engineering**

AGMA and its members are leading the power transmission industry into a stronger 2021. Join AGMA, the exhibitors you see listed here — industry leaders and experts in all sectors of manufacturing — in our commitment to MPT Expo and the global supply chain.

IF WE ARE ALL IN, WE ALL WIN.



»»» **LEARN MORE AT MotionPowerExpo.com**

2020 PTE Buyers Guide

About This Directory

The 2020 *Power Transmission Engineering Buyers Guide* was compiled to provide you with a handy resource containing the contact information for significant suppliers of power transmission components.

ACCESSORIES	34
ACTUATORS	37
ADJUSTABLE SPEED DRIVES	39
BEARINGS	41
BELTING & BELT DRIVES	43
BRAKES	45
CHAIN & CHAIN DRIVES	46
CLUTCHES	47
CONTROLS	48
COUPLINGS & U-JOINTS	50
FLUID POWER	52
GEAR DRIVES	52
GEAR MANUFACTURING SERVICES	55
GEARS	57
INDUSTRIAL HARDWARE AND MACHINE PARTS	60
LINEAR MOTION DEVICES	61
LUBRICATION	62
MOTORS	63
RESOURCES	64
SEALS	65
SENSORS	65
SOFTWARE	66

Bold Listings throughout the Buyers Guide indicate that a company has an advertisement in this issue of *Power Transmission Engineering*.

How to Get Listed in the Buyers Guide

Although every effort has been made to ensure that this Buyers Guide is as comprehensive, complete and accurate as possible, some companies may have been inadvertently omitted. If you'd like to add your company to the directory, we welcome you. Please visit www.powertransmission.com/getlisted.php to fill out a short form with your company information and Buyers Guide categories. These listings will appear online at www.powertransmission.com, and those listed online will automatically appear in next year's printed Buyers Guide.

Handy Online Resources

The *Power Transmission Engineering Buyers Guide* – The listings printed here are just the basics. Visit our online buyers guide for the most comprehensive directory of suppliers of gears, bearings, motors, clutches, couplings, gear drives and other mechanical power transmission components, broken down into sub-category by type of product manufactured: www.powertransmission.com/directory/



The **Gear Industry Buyers Guide** – If you manufacture gears or need information on suppliers of machine tools, tooling and services for gear manufacturers, please visit the buyers guide on *Gear Technology's* website:

www.geartechology.com/dir/

ACCESSORIES

ABB Motors and Mechanical Inc.
www.baldor.com

ABL Products Incorporated
www.ablproducts.com

Accent Bearings Co. Inc.
www.accentbearing.com

Ace World Companies
www.aceworldcompanies.com

Acorn Industrial Services Ltd.
www.acorn-ind.co.uk

Advanced Technology Services, Inc.
www.advancedtech.com

Advanced Test & Automation Inc.
www.advancedta.com

Aerotech Inc.
www.aerotech.com

Affiliated Distributors
www.adhq.com

AGI Automation Components
www.agi-automation.com

AIMS Industrial Supplies
www.aimsindustrial.com.au

AISCO Industrial Couplings
www.aiscoinc.com

Akron Gear and Engineering
www.akrongear.com

Allied International
www.alliedinter.com

Amacoil, Inc.
www.amacoil.com

American Collars & Couplings Inc.
www.americancollars.com

Ametric / American Metric Corporation
www.ametric.com

AmTech International
www.amtechinternational.com

Andec Mfg. Ltd.
www.andec.ca

Applied Dynamics
www.applied-dynamics.com

Area Distributors Inc.
www.aredist.com

Artec Machine Systems
www.artec-machine.com

Ascent Precision Gear Corporation
www.ascentgear.com

Ashutosh Power TransBelts Limited
www.aptbelts.com

ASI Technologies Inc.
www.asidrives.com

AST Bearings
www.astbearings.com

Atlanta Drive Systems Inc.
www.atlantadrives.com

ATO Inc
www.ato.com

Avalon International Corp.
www.avalongateway.com

AV Industrial Products Ltd
www.avindustrialproducts.co.uk

Axu s.r.l.
www.axu.it

B&B Manufacturing, Inc.
www.bbman.com

Baart Industrial Group
www.baartgroup.com

Bartlett Bearing Company, Inc.
www.bartlettbearing.com

BDI - Bearing Distributors Inc.
www.bdiexpress.com

Bearing Boys Ltd
www.bearingboys.co.uk

Bearing Engineering Company
bearingengineering.com

Bearing Headquarters
www.bearingheadquarters.com

Bearings and Industrial Supply Company, Inc.
www.bearingsnow.com

Bearing Service Company
www.bearing-service.com

Bearings Limited
www.bearingslimited.com

BellowTech, LLC
www.bellowstech.com

Bevel Gears India Pvt. Ltd.
bevelgearsindia.com

Bishop-Wisecarver Corp.
www.bwc.com

BK Power Systems - An Integrated Corrosion Co.
www.bkpowersystems.com

BRECOflex CO., L.L.C.
www.brecoflex.com

Brewer Machine & Gear Co.
www.brewertensioner.com

BSF, Inc.
www.bsfinc.net

C-Flex Bearing Co., Inc.
www.c-flex.com

Canto Engineering Company
www.cantoengineering.com

CCTY Bearing
www.CCTYBearing.com

CENTA Power Transmission
www.centa.info

Challenge Power Transmission (Aust) Pty Ltd
www.challengept.com

Challenge Power Transmission PLC
www.challengept.com

Checkfluid
www.checkfluid.com

Cleveland Gear Co.
www.clevelandgear.com

CMS Vibration Solutions Ltd.
www.cmsantivibration.co.uk

Collars and Couplings Inc.
www.collarsandcouplings.com

ComInTec
www.comintec.com

Comtec Mfg., Inc.
www.comtecmfg.com

Cross + Morse
www.crossmorse.com

C R Products Ltd.
www.c-rproducts.com

Currie Enterprises
www.currieenterprises.com

Custom Machine & Tool Co. Inc.
www.cmtco.com

Cyclo-Index
www.cycloindex.com

Daemar Inc.
www.daemar.com

Daido Corporation of America
www.daidocorp.com

Dalton Bearing Service, Inc.
www.daltonbearing.com

Darbar Belting
www.darbarbelting.co.in

Datasyst Engineering & Testing Services, Inc.
www.datasystest.com

Daubert Cromwell LLC
www.daubertcromwell.com

Davall Gears Ltd.
www.davall.com

David Brown Santasalo Canada Service Inc.
www.dbsantasalo.com

Del-Tron Precision Inc.
www.deltron.com

Distag QCS
www.distag.com

Dover Motion
www.dovermotion.com

Drive Components LLC
www.drivecomponentsllc.com

Drive Systems Technology Inc.
www.gear-doc.com

Dynatect Manufacturing Inc. (fka A & A Mfg.)
www.dynatect.com

Eagle PLC
www.eagleplc.com

Electro Steel Engineering Company
www.fenner.in

Elkem Silicones
www.silicones.elkem.com

Emerson Industrial Automation - Drives & Motor
www.emerson.com/en-us/automation-solutions

Ensinger Precision Components
www.plastockonline.com

EquipNet
www.equipnet.com

Filter Pumper / Hydraulic Problems, Inc.
www.filterpumper.com

Fixtureworks
www.fixtureworks.net

Flux Drive Inc.
www.fluxdrive.com

Force Control

3660 DIXIE HIGHWAY
FAIRFIELD, OH 45014
Phone: (513) 868-0900
Fax: (513) 868-2105
info@forcecontrol.com
www.forcecontrol.com

SEE OUR AD
P17

Forgital Group
www.forgital.com

Framo Morat Inc.
www.framo-morat.com

Friel Metal Resurfacing
www.frielmetalresurfacing.com

Functional Oil Seal Industrial Co., Ltd. - FOS
www.fos.com.tw

G.L. Huyett
www.huyett.com

Gallagher Fluid Seals, Inc.
www.gallagherseals.com

Gates Corporation
www.gates.com

Gayatri Gear Industries
www.gayatrigear.com

Gear Master Inc.
www.gearmaster.us

GearTec
www.geartec.com

Gibbs Gears Precision Engineers
www.gibbsgears.com

Gleason Plastic Gears
www.gleasonplasticgears.com

Hangzhou Ocean Industry Co., Ltd.
www.hzoic.com

Hangzhou Shengda Bearing Co
www.china-sda.com/product/draglink/

Hangzhou Xingda Machinery Co. Ltd.
www.xdmade.com

Hayes Manufacturing Inc.
hayescouplings.com

HBM
www.hbm.com

Heidenhain Corporation
www.heidenhain.com

Hi-Grade Inc.
www.higradeinc.com

Huzhou Fuda Electrical Technology Co.,Ltd
www.fd-enameledwire.com

HVH Industrial Solutions
hvhindustrial.com

IBT Industrial Solutions
www.ibtinc.com

IDA Motion Inc.
www.idamotion.com

IKO International Inc.
www.ikont.com

IMS LLC
www.intermotionsupply.com

Industrial Automation Co.
www.industrialautomation.co

Industrial Pulley & Machine Co, Inc.
www.industrialpulley.com

Industrial Spares Manufacturing Co.
www.industrialsparesfromindia.com

Intech Corporation
www.intechpower.com

Integrated Components Inc.
www.integratedcomponentsinc.com

Intellidrives, Inc
www.intellidrives.com

Inolute Powergear Pvt. Ltd.
www.inolutetools.com

ISC Companies
isccompanies.com

J.W. Winco Inc.
www.jwwinco.com

YOUR BEST SOURCE FOR METRIC

MOTORS, GEARBOXES & COOLANT PUMPS

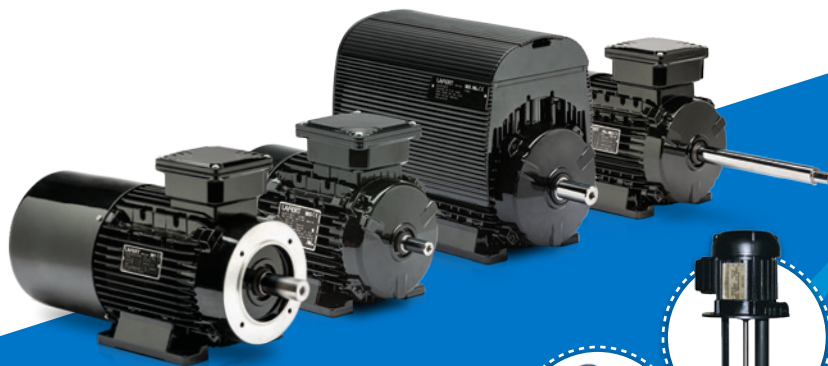

Toll Free: 1.800.661.6413 Fax: 1.905.629.2852
www.lafertna.com Sales1@lafertna.com

Copyright Lafert North America 2017. All rights reserved.



Jason Industrial Inc.
www.jasonindustrial.com

jbj Techniques Limited
www.jbj.co.uk

Juncera Automations
junceraautomations.com

JVL Industri Elektronik A/S
www.jvl.dk

K+S Services
www.k-and-s.com

Kamar Industries
www.kamarindustries.com

KBK Antriebstechnik GmbH
www.kbk-antriebstechnik.de

KEB America, Inc.
keblog.com

Kiesler Machine Inc.
www.kieslermachine.com

Kinematics Manufacturing, Inc.
www.kinematicsmfg.com

Kluber Lubrication North America L.P.
www.kluber.com

Kollmorgen
www.kollmorgen.com

KTR Corporation
www.ktr.com/us

Lafert North America

5620 KENNEDY ROAD
MISSISSAUGA ON L4Z 2A9
CANADA

Phone: (905) 629-1939 or toll free (800) 661-6413

Fax: (905) 629-2852

sales@lafertna.com

www.lafertna.com

LM76 Linear Motion Bearings
www.LM76.com

Lovejoy, Inc. (A Timken Brand)
www.lovejoy-inc.com

Machine Guard & Cover Co.
machineguard.com

Machinists Inc.
machinistsinc.com

Magnum Manufacturing
magnum-mfg.com

Magtrol, Inc.
www.magtrol.com

Maguire Technologies
www.maguiretech.com

Malloy Electric
www.MalloyWind.com

Martin Sprocket & Gear
www.martinsprocket.com

MasterDrive, Inc.
www.masterdrives.com

Maurey Manufacturing Corporation
www.maurey.biz

Maxcess
www.maxcessintl.com

Maxon Precision Motors
www.maxonmotorusa.com

Metric & Multistandard Components Corp
www.metricmcc.com

MFG Components Oy
www.mfg.fi

Micronor Inc.
www.micronor.com

Miki Pulley

13200 6TH AVENUE NORTH
PLYMOUTH, MN 55441

Phone: (800) 533-1731

Fax: (763) 546-8260

sales@mikipulley-us.com

www.mikipulley-us.com

Ming Chang Traffic Parts Mfg.
www.mcchain.com.tw

Minh Anh Technology Solution Company Limited
www.masco.vn

Mini-Broach Machine Company
minibroach.com

Minsk Gear Works
www.mgw.by

Mitsubishi Belting LTD/MBL (USA) Corp
www.mblusa.com

MMB Bearing Co. Inc.
www.mmbbearings.net

MMR Precision Gears
www.mastermachinerepair.com

Motion Industries
www.motionindustries.com

Moventas Ltd.
www.moventas.com

MPT Drives, Inc.
www.mptdrives.com

MRO Electric and Supply
www.mroelectric.com

MROSupply
www.mrosupply.com

MT Tool & Manufacturing
www.mttoolinc.com

Muratech Engineering Company
www.muracopower.co.in

NDE Power Transmissions
www.ndepower.com

Netshape Technologies, Inc.
www.netshapetech.com

New England Belting Company
www.newenglandbelting.com

Nichiei Company, Ltd.

54 TOMAHAWK TRAIL
SPARTA, NEW JERSEY 07871

Phone: 973-729-2355

lizgershon@att.net

www.nichiei-ind.com/english/index.html

Nordex, Inc.

426 FEDERAL ROAD
BROOKFIELD, CT 06804

Phone: 203-775-4877

Fax: 203-775-6552

sales@nordex.com

www.nordex.com

Northwest Electric Motor Company
northwestmotor.com

Novotec Argentina SRL
www.novotecargentina.com

NSK Corporation
www.nskamericas.com/en/industries/industrial/power-transmission.html

Ondrives US Corp.
www.ondrivesus.com

Onvio LLC
www.onviollc.com

Orttech
www.orttech.com

P.T. International Corp. (PTI)
www.ptintl.com

PI (Physik Instrumente) L.P. Piezo Actuator Nano
www.pi-usa.us

PIC Design
www.pic-design.com

Pinpoint Laser Systems
pinpointlaser.com

Pioneer Motor Bearing Co.
www.pioneer1.com

Pix Transmissions Limited
www.pixtrans.com

Plastock - Putnam Precision Molding, Inc.
www.plastockonline.com

Potomac Electric
www.potomacelectric.com

PowerDrive LLC
www.powerdrive.com

SEE OUR AD
P35

SEE OUR AD
P38

SEE OUR AD
P59

SEE OUR AD
P69

60 Years Trusted



ROBOTICS • AEROSPACE • DEFENSE • TRANSPORTATION • MEDICAL

Our gears are trusted by some of the most advanced agencies in the world.

Does your application require greater torque in less space? Spiroid's skew-axis, high torque gears enable world-class power density in a small footprint. **Consult our engineers today!**

(320) 762-7133

info@SpiroidGearing.com



Visit online to learn more. SpiroidGearing.com

Precipart
www.precipart.com

Productivity Inc.
www.productivity.com

Pulley Manufacturers International Inc.
www.pulleys.com

QA1
www.qa1.net/industrial

Quality Bearings & Components

250 DUFFY AVENUE
HICKSVILLE, NY 11801
Phone: (516) 616-0436
Fax: (516) 616-0443
qbcsupport@qbcbearings.com
www.qbcbearings.com

SEE OUR AD
P25,43

Regal

200 STATE STREET
BELOIT WI 53511
Phone: 800-626-2120
Fax: (800) 262-3292
lan.Rubin@regalbeloit.com
www.regalbeloit.com

SEE OUR AD
P13

René Baer AG
www.renebaerag.ch

Renishaw Inc
www.renishaw.com

Resistoflex Private Limited
www.resistoflex.in

Rexnord
www.rexnord.com

RGW Sales Canada
www.rgwsalescanada.com

Ringball Corporation
www.ringball.com

Ringfeder Power Transmission USA Corp.
www.ringfeder.com

Ringspann Corporation
www.ringspanncorp.com

Ritbearing Corp.
www.ritbearing.com

Rockwell Automation
www.rockwellautomation.com

Romax Technology Limited
www.romaxtech.com

Rotor Clip Company, Inc.
www.rotorclip.com

Rubena a.s.
www.rubena.cz

Ruland Manufacturing Co., Inc.
www.ruland.com

Schenck USA
www.schenck-usa.com

Servometer
www.servometer.com

SEW-Eurodrive

1295 OLD SPARTANBURG HWY.
P.O. BOX 518
LYMAN, SC 29635
Phone: (864) 439-7537
Fax: (864) 439-7830
www.seweurodrive.com

SEE OUR AD
IBC

Shanghai Shine Transmission Machinery Co. Ltd.
www.syptworld.com

Shijiazhuang CAPT Power Transmission Co., Ltd
www.chssb.com

Sichuan Mighty Machinery Co. Ltd.
www.sc-mighty.com

Simatec Inc.
www.simatec.com

SIPCO

12610 GALVESTON ROAD
WEBSTER TX 77598
Phone: 2814808711
www.sipco-mls.com

SEE OUR AD
P69

SKF USA Inc.
www.skf.com

SMT - Smart Manufacturing Technology

CHARTWELL HOUSE
67-69 HOUNDS GATE
NOTTINGHAM NG1 6BB
UK
Phone: +44 (0)115 941 9839
Fax: +44 (0)115 958 1583
info@smartmt.com
www.smartmt.com

SEE OUR AD
P15

Special Ingranaggi
www.specialingranaggi.com/en/

Spiroid Gearing

1601 36TH AVENUE
ALEXANDRIA, MN 56308
Phone: (320) 762-7132
www.spiroidgearing.com

SEE OUR AD
P36

SPN Schwaben Praezision
www.spn-hopf.de

Sprockets Australia Pty. Ltd.
sprocketsoz.com.au

SPX Cooling Technologies, Inc.
www.spxcooling.com

SSP Manufacturing, Inc
www.sspseals.com

Stearns
www.stearnsbrakes.com

The Steel Plate & Component Factory
www.steelplates.in

Steinmeyer Inc.
www.steinmeyer.com

Stock Drive Products/Sterling Instrument (SDP/SI)

250 DUFFY AVENUE
HICKSVILLE, NY 11801
Phone: (516) 328-3300
Fax: (516) 326-8827
sdp-sisupport@sdp-si.com
www.sdp-si.com

SEE OUR AD
P19

Stoffel Polygon Systems, Inc.
www.stoffelpolygon.com

Tampa Armature Works- TAW
www.tawinc.com

Tapeswitch Corporation
www.tapeswitch.com

Team Industries
www.team-ind.com

Technico
www.technico.com

Therm-X
www.therm-x.com

Thomson Industries Inc.
www.thomsonlinear.com

Torque Transmission
www.torquetrans.com

Transmission Machinery Co., Ltd
www.transcyko-transstec.com

Transply Inc.
www.transply.com

Trojon Gear Inc.
www.trojon-gear.com

TSS Rotterdam B.V.
www.tssr.nl

Tsubaki of Canada Limited
www.tsubaki.ca

Turbo Couplings Co. Ltd.
www.turbokaplin.com.tr

TVT America, Inc.
www.tvtamerica.com

Twin Spring Coupling LLC

226 BLAUVELT ROAD
PEARL RIVER, NY 10965
Phone: 7189381950
Fax: 8459201258
darrenf@twinspringcoupling.com
www.twinspringcoupling.com

SEE OUR AD
P52

U.S. Tsubaki

301 E. MARQUARDT DR.
WHEELING, IL 60090
Phone: (847) 459-9500
Fax: (847) 459-9515
sales@ustsubaki.com
www.ustsubaki.com

SEE OUR AD
P31

United Gear Works
unitedgearworks.com

USA Borescopes
www.USABorescopes.com

VCST LP
www.vcst.be

Vision Quality Components, Inc
www.visionqci.com

VL Motion Systems Inc.
www.vlmotion.com

Voith Turbo Inc
voith.com/usa/en/index.html

W.M. Berg
www.wmberg.com

Wajax
www.wajax.com

Warner Linear
www.warnerlinear.com

WD Bearing America
www.wd-bearings.com

Whitmore
whitmores.com

Whittet-Higgins Company
whittet-higgins.com

WJB Group
www.wjbgroupp.com

WMH Transmissions Ltd
www.wmh-trans.co.uk

WorldWide Electric Corporation

3540 WINTON PLACE
ROCHESTER NY 14623
Phone: 800-808-2131
Fax: 800-711-1616
customerservice@worldwideelectric.net
www.worldwideelectric.net

SEE OUR AD
P12

York Industries
www.york-ind.com

Zerelli Technologies Inc
www.zerelli.com

ACTUATORS

Acme Gear Co.
www.acmegear.com

Acorn Industrial Services Ltd.
www.acorn-ind.co.uk

Aerotech Inc.
www.aerotech.com

Affiliated Distributors
www.adhq.com

AGI Automation Components
www.agi-automation.com

Agnee Transmissions (I) Pvt Ltd
www.agneetransmissions.com

Agro Engineers
www.agroengineers.com

AIMS Industrial Supplies
www.aimsindustrial.com.au

Akgears, LLC
www.ahgears.com

Allied Motion
www.alliedmotion.com

Amacoil, Inc.
www.amacoil.com

Ametric / American Metric Corporation
www.ametric.com

Anaheim Automation, Inc.
www.anaheimautomation.com

Arnold Magnetic Technologies
www.arnoldmagnetics.com



THIN ENOUGH?

BXR Brakes

- Up to 480 in-lbs static
- Up to a 1.125" bore
- 19 watts or less
- Produced for over 10 years

Our Innovative design features a very thin profile, reducing weight and saving space.

For more information:
Call: 800.533.1731
www.mikipulley-us.com



Atlanta Drive Systems Inc.
www.atlantadrives.com

ATO Inc
www.ato.com

Avion Technologies Inc.
www.avion-tech.com

BDI - Bearing Distributors Inc.
www.bdiexpress.com

Bearing Engineering Company
bearingengineering.com

Bearing Headquarters
www.bearingheadquarters.com

Beaver Aerospace and Defense Inc.
www.beaver-online.com

Befared
www.befared.com.pl

BellowsTech, LLC
www.bellowstech.com

Bevel Gears India Pvt. Ltd.
bevelgearsindia.com

Bharat Gears Ltd.
www.bharatgears.com

Bishop-Wisecarver Corp.
www.bwc.com

BK Power Systems - An Integrated Corrosion Co.
www.bkpowersystems.com

Bosch Rexroth
www.boschrexroth-us.com

Buehler Motor, Inc.
www.buehlermotor.com

Central Gear & Machine
www.cgmatlanta.com

Control Switches International Inc
www.controlswitches.com

Curtis Machine Co. Inc.
curtismachine.com

Dalton Bearing Service, Inc.
www.daltonbearing.com

Del-Tron Precision Inc.
www.deltron.com

Discovery Technology International, Inc.
www.dtimotors.com

Dongyang Anuze Motor Smartech Co. Ltd.
www.microgearmotor.com

Dover Motion
www.dovermotion.com

Drive Lines Technologies Ltd
www.drivelines.co.uk

Duff-Norton
www.duffnorton.com

Duff Norton Australia
www.duffnorton.com.au

Dunkermotoren USA Inc.
www.dunkermotoren.com

Dynamic Structures and Materials, LLC
www.dynamic-structures.com

Dynatect Manufacturing Inc. (fka A & A Mfg.)
www.dynatect.com

Emerson Industrial Automation - Drives & Motor
www.emerson.com/en-us/automation-solutions

Exlar Actuation Solutions
www.exlar.com

Festo Corporation
www.festo.com/usa

FMC Engineering
www.fmcengineering.com

Framo Morat Inc.
www.framo-morat.com

GearTec
www.geartec.com

Gibbs Gears Precision Engineers
www.gibbsgears.com

Gil Equipamentos Industriais Ltda.
www.gil.com.br

Gleason Plastic Gears
www.gleasonplasticgears.com

H2W Technologies
www.h2wtech.com

Hallmark Industries Inc.
www.hallmarkind.com

Hangzhou Shengda Bearing Co
www.china-sda.com/product/draglink

Hidrax
www.hidrax.eu/en/

Houston Pump and Gear
www.houstonpumpandgear.com

HVH Industrial Solutions
hvhindustrial.com

IAI America, Inc.
www.intelligentactuator.com

IBT Industrial Solutions
www.ibtinc.com

IKO International Inc.
www.ikont.com

IMS LLC
www.intermotionsupply.com

Integrated Components Inc.
www.integratedcomponentsinc.com

Intellidrives, Inc
www.intellidrives.com

ISC Companies
isccompanies.com

JoVal Machine Company
www.jovalmachine.com

Juncera Automations
junceraautomations.com

K+S Services
www.k-and-s.com

Kamar Industries
www.kamarindustries.com

KEB America, Inc.
keblog.com

Kinematics Manufacturing, Inc.
www.kinematicsmfg.com

Kollmorgen
www.kollmorgen.com

LYC North America Inc
lycbearings.com

Machinists Inc.
machinistsinc.com

Malloy Electric
www.MalloyWind.com

Mavilor Motors, S.a.
www.mavilor.es

Maxcess
www.maxcessintl.com

Midwest Motion Products
www.midwestmotion.com

Motion Industries
www.motionindustries.com

MPT Drives, Inc.
www.mptdrives.com

MROSupply
www.mrosupply.com

NGT Specialty Valves
www.ngtvalves.com

Niebuhr Gears
www.niebuhr.dk

Ningbo Zhongyi Hydraulic Motor Co. Ltd.
www.zihyd.com

Nordex, Inc.
426 FEDERAL ROAD
BROOKFIELD, CT 06804
Phone: 203-775-4877
Fax: 203-775-6552
sales@nordex.com
www.nordex.com

Northwest Electric Motor Company
northwestmotor.com

Novotec Argentina SRL
www.novotecargentina.com

SEE OUR AD
P69

NSK Corporation
www.nskamericas.com/en/industries/industrial/power-transmission.html

Orbitless Drives, Inc
www.orbitless.com

Parker Hannifin SSD Drives Div.
www.parker.com/ssdusa

Performance Gear Systems, Inc.
www.performance-gear.com

PI (Physik Instrumente) L.P. Piezo Actuator Nano
www.pi-usa.us

Portescap
www.portescap.com

Potomac Electric
www.potomacelectric.com

Power Electric
www.powerelectric.com

Power Jack Motion
www.powerjackmotion.com

Precipart
www.precipart.com

Precision Pump and Gear Works
www.ppg-works.com

PST Group (Precision Screw Thread)
www.thepstgroup.com

Rex Engineering Corp.
www.rex-engineering.com

RGW Sales Canada
www.rgwsalescanada.com

Riley Gear Corporation
www.rileygear.com

Ringball Corporation
www.ringball.com

Rockwell Automation
www.rockwellautomation.com

Rolling Motion Industries
www.rmldrive.com

S.M. Shah & Company
hydraulicvanepump.com

Schaeffler Group USA Inc.
308 SPRINGHILL FARM ROAD
FORT MILL, SC 29715
Phone: (803) 548-8500
Fax: (803) 548-8599
info.us@schaeffler.com
www.schaeffler.us

SEE OUR AD
BOC

Schneider Electric Motion USA
motion.schneider-electric.com

Sensata Technologies
www.sensata.com

SEPAAC Inc
www.sepac.com

Serapid Inc.
www.serapid.us

Servometer
www.servometer.com

Sesame Motor Corp.
www.sesamemotor.com.tw

SEW-Eurodrive
1295 OLD SPARTANBURG HWY.
P.O. BOX 518
LYMAN, SC 29635
Phone: (864) 439-7537
Fax: (864) 439-7830
www.seweurodrive.com

SEE OUR AD
IBC

Shijiazhuang CAPT Power Transmission Co., Ltd
www.chssb.com

SIPCO
12610 GALVESTON ROAD
WEBSTER TX 77598
Phone: 2814808711
www.sipco-mls.com

SEE OUR AD
P69

SKF USA Inc.
www.skf.com

Southern Gear & Machine
www.southerngear.net

Spiroid Gearing
1601 36TH AVENUE
ALEXANDRIA, MN 56308
Phone: (320) 762-7132
www.spiroidgearing.com

SEE OUR AD
P36

SPN Schwaben Praezision
www.spn-hopf.de

Steinmeyer Inc.
www.steinmeyer.com

Stock Drive Products/Sterling Instrument (SDP/SI)
250 DUFFY AVENUE
HICKSVILLE, NY 11801
Phone: (516) 328-3300
Fax: (516) 326-8827
sdp-sisupport@sdp-si.com
www.sdp-si.com

SEE OUR AD
P19

Stoffel Polygon Systems, Inc.
www.stoffelpolygon.com

Technico
www.technico.com

Thomson Industries Inc.
www.thomsonlinear.com

Tolomatic, Inc.
www.tolomatic.com

TVT America, Inc.
www.tvtamerica.com

Varitron Engineering (Taiwan) Co., Ltd
www.c-var.com

Venture Mfg. Co.
www.venturemfgco.com

VL Motion Systems Inc.
www.vlmotion.com

Voith Turbo Inc
voith.com/usa/en/index.html

Wajax
www.wajax.com

Warner Linear
www.warnerlinear.com

WEG
www.weg.net

Wittenstein
www.wittenstein-us.com

Yantai Bonway Manufacturer Co. Ltd.
www.bonwaygroup.com

ADJUSTABLE SPEED DRIVES

ABB Motors and Mechanical Inc.
www.baldor.com

ABM DRIVES INC.
abm-drives.us

Ace World Companies
www.aceworldcompanies.com

Acme Gear Co.
www.acmegear.com

Acorn Industrial Services Ltd.
www.acorn-ind.co.uk

Aerotech Inc.
www.aerotech.com

Affiliated Distributors
www.adhq.com

Agro Engineers
www.agroengineers.com

AIMS Industrial Supplies
www.aimsindustrial.com.au

AISCO Industrial Couplings
www.aiscoinc.com

Akgears, LLC
www.ahkgears.com

Allied Motion
www.alliedmotion.com

Amacoil, Inc.
www.amacoil.com

Ametric / American Metric Corporation
www.ametric.com

Andantex USA Inc.
1705 VALLEY ROAD
WANAMASSA, NJ 07712
Phone: (732) 493-2812
Fax: (732) 493-2949
info@andantex.com
www.andantex.com

SEE OUR AD
P11

Applied Dynamics
www.applied-dynamics.com

Area Distributors Inc.
areadist.com

ASI Technologies Inc.
www.asidrives.com

ATO Inc
www.ato.com

Automation Direct
www.automationdirect.com

Axu s.r.l.
www.axu.it

B&B Manufacturing, Inc.
www.bbman.com

BDI - Bearing Distributors Inc.
www.bdiexpress.com

Bearing Engineering Company
bearingengineering.com

Bearing Headquarters
www.bearingheadquarters.com

Bearing Service Company
www.bearing-service.com

Beaver Aerospace and Defense Inc.
www.beaver-online.com

Bevel Gears India Pvt. Ltd.
bevelgearsindia.com

Bison Gear and Engineering Corp.
www.bisongear.com

BK Power Systems - An Integrated Corrosion Co.
www.bkpowersystems.com

Bonfiglioli Riduttori S.p.A.
www.bonfiglioli.com

Bonfiglioli USA, Inc.
3541 HARGRAVE DRIVE
HEBRON KY 41048
Phone: (859) 334-3333
Fax: (859) 334-8888
mbx-industrialsalesusa@bonfiglioli.com
www.Bonfiglioli.com

SEE OUR AD
P27,53

Bosch Rexroth
www.boschrexroth-us.com

Boston Gear
www.bostongear.com

Brewer Machine & Gear Co.
www.brewertensioner.com

Buehler Motor, Inc.
www.buehlermotor.com

Carlisle Belts (A Timken Brand)
www.carlislebelts.com

Central Gear & Machine
www.cgmatlanta.com

Challenge Power Transmission PLC
www.challengept.com

Cleveland Gear Co.
www.clevelandgear.com

CNC Center
www.cnccenter.com

C R Products Ltd.
www.c-rproducts.com

Custom Motors Inc.
www.custommotorsmn.com

Cutes Corporation
www.cutes.com.tw

Dalton Bearing Service, Inc.
www.daltonbearing.com

Dana Brevini USA
www.brevini.us

Davall Gears Ltd.
www.davall.com

Dongyang Anuze Motor Smartech Co. Ltd.
www.microgearmotor.com

Dover Motion
www.dovermotion.com

Duff Norton Australia
www.duffnorton.com.au

Dunkermotoren USA Inc.
www.dunkermotoren.com

Dynex/Rivett Inc.
www.dynexhydraulics.com

Eagle PLC
www.eagleplc.com

Electronic Machine Parts
www.empregister.com

Emerson Industrial Automation - Drives & Motor
www.emerson.com/en-us/automation-solutions

Engifield Engineering
engifield.com

Essential Power Transmission Pvt. Ltd.
www.esenpro.com

Fairchild Industrial Products Co.
www.fairchildproducts.com

Festo Corporation
www.festo.comusa

Flux Drive Inc.
www.fluxdrive.com

FMC Engineering
www.fmcengineering.com

Framo Morat Inc.
www.framo-morat.com

Gayatri Gear Industries
www.gayatrigear.com

Gibbs Gears Precision Engineers
www.gibbsgears.com

Gil Equipamentos Industriais Ltda.
www.gil.com.br

Gleason Plastic Gears
www.gleasonplasticgears.com

GoHz Power Supply Inc
www.gohz.com

Hangzhou Shengda Bearing Co
www.china-sda.com/product/draglink/

Hoffmann Technics AG
www.hoffmann-tech.ch

Houston Pump and Gear
www.houstonpumpandgear.com

HPB Motion Control Co. Ltd.
www.hpb-industry.com

I-MAK Reduktor

SANAYI CAD. NO:1 / SEYHLI - PENDIK
ISTANBUL 34000
TURKEY

Phone: +90 2163780326
Fax: +902163780686
export@imakreduktor.com
www.imakreduktor.com

SEE OUR AD
P69

IBT Industrial Solutions
www.ibtinc.com

Industrial Automation Co.
www.industrialautomation.co

Intellidrives Inc
www.intellidrives.com

ISC Companies
isccompanies.com

JIE Drives

493 MISSION STREET
CAROL STREAM, IL 60188
Phone: (630) 580-9986
info@jie-drives.com
jie-drives.com

SEE OUR AD
P67

K+S Services
www.k-and-s.com

KB Controls
www.kb-controls.com

Kinematics Manufacturing, Inc.
www.kinematicsmfg.com

Kraft Power Corporation
www.kraftpower.com

Lafert North America

5620 KENNEDY ROAD
MISSISSAUGA ON L4Z 2A9
CANADA

Phone: (905) 629-1939 or toll free (800) 661-6413
Fax: (905) 629-2852
sales@lafertna.com
www.lafertna.com

SEE OUR AD
P35

Leeson Electric
www.leeson.com

Lenze Americas
www.lenze.com

Lovejoy, Inc. (A Timken Brand)
www.lovejoy-inc.com

Malloy Electric
www.MalloyWind.com

Marshall Wolf Automation Inc.
www.wolfautomation.com

Maurey Manufacturing Corporation
www.maurey.biz

Mavilor Motors, S.a.
www.mavilor.es

Maxon Precision Motors
www.maxonmotorusa.com

Miki Pulley

13200 6TH AVENUE NORTH
PLYMOUTH, MN 55441

Phone: (800) 533-1731
Fax: (763) 546-8260
sales@mikipulley-us.com
www.mikipulley-us.com

SEE OUR AD
P38

Mitsubishi Electric Automation, Inc.
us.mitsubishielectric.com/fa/en

Modicon PLC
www.modiconplc.com

Molon Motor and Coil

300 NORTH RIDGE AVE.
ARLINGTON HEIGHTS, IL 60005

Phone: (847) 253-6000
Fax: (847) 259-0299
www.molon.com

SEE OUR AD
P41

MOONS' Industries
www.moonsindustries.com

Motion Industries
www.motionindustries.com

New Power Electric (USA) LLC
www.usa-newpower.com

Nordex, Inc.

426 FEDERAL ROAD
BROOKFIELD, CT 06804

Phone: 203-775-4877
Fax: 203-775-6552
sales@nordex.com
www.nordex.com

SEE OUR AD
P69

Northwest Electric Motor Company
northwestmotor.com

Novotec Argentina SRL
www.novotecargentina.com

Orbitless Drives, Inc
www.orbitless.com

Performance Gear Systems, Inc.
www.performance-gear.com

Phytron, Inc.
www.phytron.com

PI (Physik Instrumente) L.P. Piezo Actuator Nano
www.pi-usa.us

Potomac Electric
www.potomacelectric.com

Power Electric
www.powerelectric.com

Power inverter Inc.
www.powerinverter.org

Precipart
www.precipart.com

Precision Pump and Gear Works
www.ppg-works.com

René Baer AG
www.renebaerag.ch

Renold
www.renold.com

Riley Gear Corporation
www.rileygear.com

Rockwell Automation
www.rockwellautomation.com

Rolling Motion Industries
www.rmidrive.com

S.M. Shah & Company
hydraulicvanepump.com

Schneider Electric Motion USA
motion.schneider-electric.com

Serapid Inc.
www.serapid.us

SEW-Eurodrive

1295 OLD SPARTANBURG HWY.
P.O. BOX 518

LYMAN, SC 29635
Phone: (864) 439-7537
Fax: (864) 439-7830
www.seweurodrive.com

SEE OUR AD
IBC

Siemens Industry, Inc.
www.usa.siemens.com/industry/us/en

SIPCO

12610 GALVESTON ROAD
WEBSTER TX 77598

Phone: 2814808711
www.sipco-mls.com

SEE OUR AD
P69

Siti Spa Riduttori
www.sitiriduttori.it

Sprockets Australia Pty. Ltd.
sprocketsoz.com.au

SPX Cooling Technologies, Inc.
www.spxcooling.com

STM Riduttori SpA
www.stmspa.com

Stober Drives, Inc.
www.stober.com

Stock Drive Products/Sterling Instrument (SDP/SI)

250 DUFFY AVENUE
HICKSVILLE, NY 11801

Phone: (516) 328-3300
Fax: (516) 326-8827
sdp-sisupport@sdp-si.com
www.sdp-si.com

SEE OUR AD
P19

Stoffel Polygon Systems, Inc.
www.stoffelpolygon.com

Suzhou Asia Pacific Metal Co., Ltd.
www.szapmc.com

Tampa Armature Works- TAW
www.tawinc.com

TB Wood's
www.tbwoods.com

Team Industries
www.team-ind.com

Teco Westinghouse
www.tecowestinghouse.com

Thomson Industries Inc.
www.thomsonlinear.com

Tolomatic, Inc.
www.tolomatic.com

Transply Inc.
www.transply.com

Turner Uni-Drive
www.turnerunidrive.com

TVT America, Inc.
www.tvtamerica.com

Var-Spe Variatori Oleodinamici
www.varspe.com

Vision International
www.engimech.com

VL Motion Systems Inc.
www.vlmotion.com

Voith Turbo Inc
voith.com/usa/en/index.html

Wajax
www.wajax.com

WEG
www.weg.net

WorldWide Electric Corporation

3540 WINTON PLACE
ROCHESTER NY 14623
Phone: 800-808-2131
Fax: 800-711-1616
customerservice@worldwideelectric.net
www.worldwideelectric.net

SEE OUR AD
P12

Zero-Max

13200 SIXTH AVENUE NORTH
MINNEAPOLIS, MN 55441
Phone: (763) 546-4300
Fax: (763) 546-8260
sales@zero-max.com
www.zero-max.com

SEE OUR AD
P89

BEARINGS

A&P Bearings, Inc.
www.apbearingsinc.com

ABB Motors and Mechanical Inc.
www.baldor.com

ABT Bearing
www.abtbearing.com

Accent Bearings Co. Inc.
www.accentbearing.com

Acorn Industrial Services Ltd.
www.acorn-ind.co.uk

Affiliated Distributors
www.adhq.com

AIMS Industrial Supplies
www.aimsindustrial.com.au

Allied International
www.alliedinter.com

American Swiss Products
www.americanswiss.com

Ametric / American Metric Corporation
www.ametric.com

Applied Dynamics
www.applied-dynamics.com

Area Distributors Inc.
areadist.com

Arnold Magnetic Technologies
www.arnoldmagnetics.com

ASCO Sintering Co.
www.ascosintering.com

AST Bearings
www.astbearings.com

Auburn Bearing & Manufacturing
www.auburnbearing.com

B&B Manufacturing, Inc.
www.bbman.com

Baart Industrial Group
www.baartgroup.com

Baker Bearing Company
www.bakerbearing.com

Barrel Service Company
www.barrelservice.com

Bartlett Bearing Company, Inc.
www.bartlettbearing.com

BDI - Bearing Distributors Inc.
www.bdiexpress.com

Bearing Boys Ltd
www.bearingboys.co.uk

Bearing Engineering Company
bearingengineering.com

Bearing Headquarters
www.bearingheadquarters.com

Bearings and Industrial Supply Company, Inc.
www.bearingsnow.com

Bearing Service Company
www.bearing-service.com

Bearings Limited
www.bearingslimited.com

Bishop-Wisecarver Corp.
www.bwcc.com

Bison Gear and Engineering Corp.
www.bisongear.com

BK Power Systems - An Integrated Corrosion Co.
www.bkpowersystems.com

Boca Bearing Company
www.bocabearings.com

Boston Gear
www.bostongear.com

Brewer Machine & Gear Co.
www.brewertensioner.com

C&U Americas, LLC
www.cubearing.com

C-Flex Bearing Co., Inc.
www.c-flex.com

Carlisle Belts (A Timken Brand)
www.carlislebelts.com

CCTY Bearing
www.CCTYBearing.com

Central Gear & Machine
www.cgmatlanta.com

Challenge Power Transmission (Aust) Pty Ltd
www.challengept.com

Challenge Power Transmission PLC
www.challengept.com

Craft Bearing Company, Inc.
www.craftbearing.com

Cross + Morse
www.crossmorse.com

Daemar Inc.
www.daemar.com

Dalton Bearing Service, Inc.
www.daltonbearing.com

David Brown Santasalo Canada Service Inc.
www.dbsantasalo.com

Del-Tron Precision Inc.
www.deltron.com

Discovery Technology International, Inc.
www.dtimotors.com

Dorris Gear Drives
DorrisCo.com

Drive Components LLC
www.drivecomponentsllc.com

Drive Lines Technologies Ltd
www.drivelines.co.uk

EDT Corp
www.edtcorp.com

Electro Static Technology
www.est-aegis.com

F.K. Bearings
www.fkrodends.com

FMC Engineering
www.fmcengineering.com

Forgital Group
www.forgital.com

Formsprag Clutch
www.formsprag.com

Frantz Mfg. Co.
www.frantz-mfg.com

Fusion Babbiting Co, Inc
www.fusionbabbiting.com

G.L. Huyett
www.huyett.com

GearTec
www.geartec.com

GGB Bearing Technology
www.ggbearings.com

Gil Equipamentos Industriais Ltda.
www.gil.com.br

GMN Bearing USA, Ltd.
www.gmnbt.com

MOLON
MOTOR & COIL CORPORATION

**Motor Solutions
Through
American Innovation**

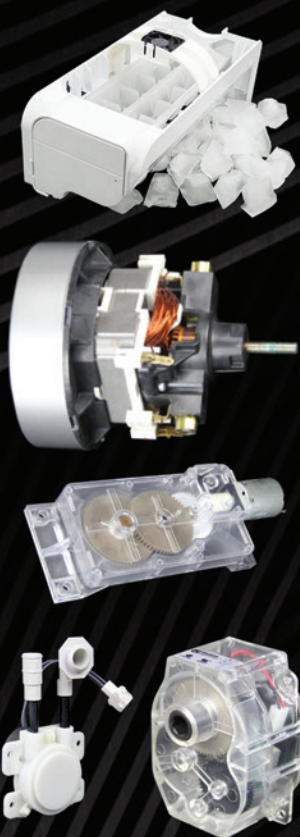

**AMERICAN
MANUFACTURER
EST. 1954**

VISIT OUR WEBSITE:



www.Molon.com



CERTIFIED
ISO 9001: 2015
CERTIFICATE NO:
10001749 QM15



CERTIFIED
ISO 13485:2016
CERTIFICATE NO:
10001749 MP2106

Hangzhou Xingda Machinery Co. Ltd.
www.xdmade.com

Houston Pump and Gear
www.houstonpumpandgear.com

HVH Industrial Solutions
hvhindustrial.com

IBT Industrial Solutions
www.ibtinc.com

IDA Motion Inc.
www.idamotion.com

IKO International Inc.
www.ikont.com

IMO USA Corp.
www.imo.us

Industrial Friction Materials Ltd.
www.industrialfriction.com

Intellidrives, Inc
www.intellidrives.com

ISC Companies
isccompanies.com

Kaydon Corporation Bearings (A SKF Brand)
www.kaydonbearings.com

Kilian Manufacturing Corp.
www.kilianbearings.com

Kinematics Manufacturing, Inc.
www.kinematicsmfg.com

LM76 Linear Motion Bearings
www.LM76.com

LYC North America Inc
lycbearings.com

Machine Guard & Cover Co.
machineguard.com

Machinists Inc.
machinistsinc.com

Maguire Technologies
www.maguiretech.com

Malloy Electric
www.MalloyWind.com

Martin Sprocket & Gear
www.martinsprocket.com

Metric & Multistandard Components Corp
www.metricmcc.com

Micronor Inc.
www.micronor.com

Mineral Circles Bearings
www.mcb.ae

MMB Bearing Co. Inc.
www.mmbbearings.net

Modern Linear Inc.
www.modernlinear.com

Motion Industries
www.motionindustries.com

Moventas Ltd.
www.moventas.com

MPT Drives, Inc.
www.mptdrives.com

MT Tool & Manufacturing
www.mttoolinc.com

Nachi America Inc.
www.nachiamerica.com



Napoleon Engineering Services

1601 JOHNSON STREET
OLEAN, NY 14760
Phone: 716-372-6532
Fax: 716-372-1448
sales@nesbearings.com
www.nesbearings.com

SEE OUR AD
P29,42

National Bearings Company
www.nationalbearings.com

NES Bearing Co., Inc.

1601 JOHNSON STREET
OLEAN, NY 14760
Phone: 716-372-6532
Fax: 716-372-1448
sales@nesbearings.com
www.nesbearings.com

SEE OUR AD
P29,42

Netshape Technologies, Inc.
www.netshapetech.com

Nichiei Company, Ltd.

54 TOMAHAWK TRAIL
SPARTA, NEW JERSEY 07871
Phone: 973-729-2355
lizgershon@att.net
www.nichiei-ind.com/english/index.html

SEE OUR AD
P59

Ningbo Hardchn Bearing Co., Ltd.
www.cnzxc.com

Nordex, Inc.

426 FEDERAL ROAD
BROOKFIELD, CT 06804
Phone: 203-775-4877
Fax: 203-775-6552
sales@nordex.com
www.nordex.com

SEE OUR AD
P69

Northwest Electric Motor Company
northwestmotor.com

Novotec Argentina SRL
www.novotecargentina.com

NSK Corporation
www.nskamericas.com/en/industries/industrial/power-transmission.html

Ondrives US Corp.
www.ondrivesus.com

Onvio LLC
www.onvio.com

P.T. International Corp. (PTI)
www.ptintl.com

Pacamor Kubar Bearings (pkb)
www.pacamor.com

Pacific Industries
www.pacificindustries.com

PEER Bearing Company
peerbearing.com

PIC Design
www.pic-design.com

Pinpoint Laser Systems
pinpointlaser.com

Pioneer Motor Bearing Co.
www.pioneer1.com

PowerDrive LLC
www.powerdrive.com

Pulley Manufacturers International Inc.
www.pulleys.com

QA1
www.qa1.net/industrial

Quality Bearings & Components

250 DUFFY AVENUE
HICKSVILLE, NY 11801
Phone: (516) 616-0436
Fax: (516) 616-0443
qbcsupport@qbcbearings.com
www.qbcbearings.com

SEE OUR AD
P25,43

RBI Bearing Inc.

101 S. GARY AVE., STE. B
ROSELLE IL 60172
Phone: 800-708-2128
Fax: (630) 295-5490
info@rbibearing.com
www.rbibearing.com

SEE OUR AD
P5

Regal

200 STATE STREET
BELOIT WI 53511
Phone: 800-626-2120
Fax: (800) 262-3292
lan.Rubin@regalbeloit.com
www.regalbeloit.com

SEE OUR AD
P13

René Baer AG
www.renebaer.ag

Renishaw Inc
www.renishaw.com

Rexnord
www.rexnord.com

RGW Sales Canada
www.rgwsalescanada.com

Ringball Corporation
www.ringball.com

Ritbearing Corp.
www.ritbearing.com

Rockwell Automation
www.rockwellautomation.com

Rubena a.s.
www.rubena.cz

Schaeffler Group USA Inc.

308 SPRINGHILL FARM ROAD
FORT MILL, SC 29715
Phone: (803) 548-8500
Fax: (803) 548-8599
info.us@schaeffler.com
www.schaeffler.us

SEE OUR AD
BOC

Shaoxing Hengyue Bearing Co., Ltd
www.nmrbearing.com

Shijiazhuang CAPT Power Transmission Co., Ltd
www.chssb.com

Sichuan Mighty Machinery Co. Ltd.
www.sc-mighty.com

SixthElementAustralia P/L
sixthelementaustralia.com

SKF USA Inc.
www.skf.com

Specialty Ring Products
www.specialtyring.com

Sprockets Australia Pty. Ltd.
sprocketsoz.com.au

SPX Cooling Technologies, Inc.
www.spxcooling.com

Stock Drive Products/Sterling Instrument (SDP/SI)

250 DUFFY AVENUE
HICKSVILLE, NY 11801
Phone: (516) 328-3300
Fax: (516) 326-8827
sdp-sisupport@sdp-si.com
www.sdp-si.com

SEE OUR AD
P19

Supreme Gear Co.
www.supremegear.com

TB Wood's
www.tbwoods.com

Thomson Industries Inc.
www.thomsonlinear.com

Thyssenkrupp Rothe Erde USA Inc.
www.thyssenkrupp-rotheerde.com

Top Machinery & Equipment (Zhengzhou) Ltd
www.top-rol.com

Torque Transmission
www.torquetrans.com

Transmission Machinery Co., Ltd
www.transcyko-transtec.com

Transply Inc.
www.transply.com

Trojan Gear Inc.
www.trojan-gear.com

TSS Rotterdam B.V.
www.tssr.nl

Tsubaki of Canada Limited
www.tsubaki.ca

United Gear Works
unitedgearworks.com

Vision Quality Components, Inc
www.visionqci.com

VL Motion Systems Inc.
www.vlmotion.com

W.M. Berg
www.wmberg.com

Wajax
www.wajax.com

WD Bearing America
www.wd-bearings.com

WJB Group
www.wjbgroup.com

WMH Transmissions Ltd
www.wmh-trans.co.uk

Xuzhou Wanda Slewing Bearing Co., Ltd.
www.slew-bearing.com

Yogi Bearings
www.yogibearings.com

York Industries
www.york-ind.com

BELTING & BELT DRIVES

ABB Motors and Mechanical Inc.
www.baldor.com

ABL Products Incorporated
www.ablproducts.com

ABM DRIVES INC.
abm-drives.us

ABT Bearing
www.abtbearing.com

Accent Bearings Co. Inc.
www.accentbearing.com

Ace World Companies
www.aceworldcompanies.com

Acorn Industrial Services Ltd.
www.acorn-ind.co.uk

Affiliated Distributors
www.adhq.com

Agro Engineers
www.agroengineers.com

AIMS Industrial Supplies
www.aimsindustrial.com.au

Akron Gear and Engineering
www.akrongear.com

Amacoil, Inc.
www.amacoil.com

American Gear & Engineering
www.americangear.net

American Gear, Inc.
www.americangearinc.com

Ametric / American Metric Corporation
www.ametric.com

Applied Dynamics
www.applied-dynamics.com

Area Distributors Inc.
areadist.com

Asahi Intecc USA, Inc.
www.asahi-inteccusa.com

Ascent Precision Gear Corporation
www.ascentgear.com

Ashutosh Power TransBelts Limited
www.aptblts.com

ATO Inc
www.ato.com

Avion Technologies Inc.
www.avion-tech.com

B&B Manufacturing, Inc.
www.bbman.com

Baart Industrial Group
www.baartgroup.com

Bartlett Bearing Company, Inc.
www.bartlettbearing.com

BDH Inc.

6975A RIVER ROAD
CONESTOGA, PA 17516
Phone: 717 871 0994
Fax: 717 871 0995
Sales@bdhbelts.com
www.bdhbelts.com

BDI - Bearing Distributors Inc.
www.bdiexpress.com

Bearing Engineering Company
bearingengineering.com

Bearing Headquarters
www.bearingheadquarters.com

Bearings and Industrial Supply Company, Inc.
www.bearingsnow.com

Bearing Service Company
www.bearing-service.com

Bervina Ltd.
www.bervina.com

Bishop-Wisecarver Corp.
www.bwc.com

BK Power Systems - An Integrated Corrosion Co.
www.bkpowersystems.com

SEE OUR AD
P68



BEARINGS

LINEAR MOTION PRODUCTS

Bearing MONITORING & MAINTENANCE TOOLS

ONE LOGICAL LOCATION

www.qbcbearings.com

Our products are high quality, efficient, competitively priced and are sourced from the most recognized names in the bearing industry.

For more information and to speak to a product specialist, call **1-888-276-4787**

Quality Bearings & Components

250 Duffy Ave.

Hicksville, NY 11801



Boca Bearing Company
www.bocabearings.com

Bonfiglioli USA, Inc.

3541 HARGRAVE DRIVE
HEBRON KY 41048
Phone: (859) 334-3333
Fax: (859) 334-8888
mbx-industrialsalesusa@bonfiglioli.com
www.Bonfiglioli.com

SEE OUR AD
P27,53

Bowman Hollis Mfg
www.bowmanhollis.com

BRECOflex CO., L.L.C.
www.brecoflex.com

Brewer Machine & Gear Co.
www.brewertensioner.com

Butler Gear
www.butlergear.com

Canto Engineering Company
www.cantoengineering.com

Capstan Atlantic
www.capstanatlantic.com

Carlisle Belts (A Timken Brand)
www.carlislebelts.com

Carnes-Miller Gear Co., Inc.
www.cmgear.com

Challenge Power Transmission (Aust) Pty Ltd
www.challengept.com

Challenge Power Transmission PLC
www.challengept.com

Chemi-Flex LLC
www.chemiflex.com

Cincinnati Gearing Systems

5757 MARIEMONT AVE.
CINCINNATI, OH 45227
Phone: (513) 527-8600
Fax: (513) 527-8635
gearsales@cst-c.com
www.cincinnati gearsystems.com

SEE OUR AD
P16

Clarke Engineering Inc. (Clarke Gear Co.)
clarkegear.com

ComInTec
www.comintec.com

Commercial Gear & Sprocket Co. Inc.
www.commercialgear.com

Comtec Mfg., Inc.
www.comtecmfg.com

Cone Drive
www.conedrive.com

ContiTech North America
www.contitech.us

Cross + Morse
www.crossmorse.com

C R Products Ltd.
www.c-rproducts.com

Custom Machine & Tool Co. Inc.
www.cmtco.com

Dalton Bearing Service, Inc.
www.daltonbearing.com

Darbar Belting
www.darbarbelting.co.in

Davall Gears Ltd.
www.davall.com

Dee Bee Enterprise
www.deebie-enterprise.com

Del-Tron Precision Inc.
www.deltron.com

Delta Gear Corp.
www.delta-gear.com

Desch Canada Ltd.
www.desch.de

Dimatic Die & Tool Co.
www.dimatic.com

Distag QCS
www.distag.com

Dorris Gear Drives
DorrisCo.com

Drive Components LLC
www.drivecomponentsllc.com

Dura-Belt
www.durabelt.com

Dymco, Co
www.steelbelt.jp/index.php

Electro Steel Engineering Company
www.fenner.in

Elliott Manufacturing
www.elliottmfg.com

Ensinger Precision Components
www.plastockonline.com

Excel Gear, Inc.
www.excelgear.com

First Gear Engineering & Technology
www.first-gear.com

Flux Drive Inc.
www.fluxdrive.com

Forest City Gear Co.

11715 MAIN STREET
ROSCOE, IL 61073
Phone: (815) 623-2168
Fax: (815) 623-6620
www.forestcitygear.com

SEE OUR AD
P3

Framo Morat Inc.
www.framo-morat.com

Gates Corporation
www.gates.com

Gayatri Gear Industries
www.gayatrigeear.com

Gear Design & Service Pty. Ltd.
www.geardesign.com.au

Gear Motions, Inc.
www.gearmotions.com

George Lane & Sons Ltd
www.georgelane.co.uk

Gibbs Gears Precision Engineers
www.gibbsgears.com

Gil Equipamentos Industriais Ltda.
www.gil.com.br

Gleason Plastic Gears
www.gleasonplasticgears.com

GoHz Power Supply Inc
www.gohz.com

Hangzhou Ocean Industry Co., Ltd.
www.hzoic.com

Hangzhou Xingda Machinery Co. Ltd.
www.xdmade.com

Hayes Manufacturing Inc.
hayescouplings.com

HVH Industrial Solutions
hvhindustrial.com

I-MAK Reduktor

SANAYI CAD. NO:1 / SEYHLI - PENDIK
ISTANBUL 34000
TURKEY
Phone: +90 2163780326
Fax: +902163780686
export@imakreduktor.com
www.imakreduktor.com

SEE OUR AD
P69

IBT Industrial Solutions
www.ibtinc.com

Industrial Pulley & Machine Co, Inc.
www.industrialpulley.com

Intech Corporation
www.intechpower.com

Involute Powergear Pvt. Ltd.
www.involutetools.com

ISC Companies
isccompanies.com

Jason Industrial Inc.
www.jasonindustrial.com

Kamar Industries
www.kamarindustries.com

Kapsyn Manufacturing Company
www.kapsyn.com

Kinematics Manufacturing, Inc.
www.kinematicsmfg.com

Leeson Electric
www.leeson.com

Lovejoy, Inc. (A Timken Brand)
www.lovejoy-inc.com

Machine Guard & Cover Co.
machineguard.com

Machinists Inc.
machinistsinc.com

Malloy Electric
www.MalloyWind.com

Martin Sprocket & Gear
www.martinsprocket.com

MasterDrive, Inc.
www.masterdrives.com

Maurey Manufacturing Corporation
www.maurey.biz

MES INC
www.mesinc.net

MFG Components Oy
www.mfg.fi

Midwest Brake
www.midwestbrake.com

Miki Pulley

13200 6TH AVENUE NORTH
PLYMOUTH, MN 55441
Phone: (800) 533-1731
Fax: (763) 546-8260
sales@mikipulley-us.com
www.mikipulley-us.com

SEE OUR AD
P38

Ming Chang Traffic Parts Mfg.
www.mccchain.com.tw

Mitsubishi Belting LTD/MBL (USA) Corp
www.mblusa.com

Motion Industries
www.motionindustries.com

MPT Drives, Inc.
www.mptdrives.com

MT Tool & Manufacturing
www.mttoolinc.com

Muratech Engineering Company
www.muracopower.co.in

Nav Auxichem Pvt. Ltd
www.perfectbelting.com

Neelkanth Beltings
www.neelkanthbeltings.com

Netshape Technologies, Inc.
www.netshapetech.com

New England Belting Company
www.newenglandbelting.com

Nichiei Company, Ltd.

54 TOMAHAWK TRAIL
SPARTA, NEW JERSEY 07871
Phone: 973-729-2355
lizgershon@att.net
www.nichiei-ind.com/english/index.html

SEE OUR AD
P59

Ningbo Fulong Synchronous Belt Co. Ltd.
www.cnfulo.com

Nordex, Inc.

426 FEDERAL ROAD
BROOKFIELD, CT 06804
Phone: 203-775-4877
Fax: 203-775-6552
sales@nordex.com
www.nordex.com

SEE OUR AD
P69

Northwest Electric Motor Company
northwestmotor.com

Novotec Argentina SRL
www.novotecargentina.com

Ondrives US Corp.
www.ondrivesus.com

Ontario Gear and Spline
www.ontariogearandspline.com

Onvio LLC
www.onviollc.com

P.T. International Corp. (PTI)
www.ptintl.com

Perry Technology Corporation
www.perrygear.com

PIC Design
www.pic-design.com

Pix Transmissions Limited
www.pixtrans.com

Plastock - Putnam Precision Molding, Inc.
www.plastockonline.com

PowerDrive LLC
www.powerdrive.com

Premier Udyog
www.premierudyog.org

Pulley Manufacturers International Inc.
www.pulleys.com

Regal
200 STATE STREET
BELOIT WI 53511
Phone: 800-626-2120
Fax: (800) 262-3292
lan.Rubin@regalbeloit.com
www.regalbeloit.com

SEE OUR AD
P13

René Baer AG
www.renebaerag.ch

Rexnord
www.rexnord.com

RGW Sales Canada
www.rgwsalescanada.com

Ringball Corporation
www.ringball.com

Rockwell Automation
www.rockwellautomation.com

Rubena a.s.
www.rubena.cz

Rush Gears Inc.
www.rushgears.com

Schafer Industries
www.schafergear.com

Shanghai Shine Transmission Machinery Co. Ltd.
www.syptworld.com

Shijiazhuang CAPT Power Transmission Co., Ltd
www.chssb.com

Sichuan Mighty Machinery Co. Ltd.
www.sc-mighty.com

SKF USA Inc.
www.skf.com

Southern Gear & Machine
www.southerngear.net

Special Ingranaggi
www.specialingranaggi.com/en/

Sprockets Australia Pty. Ltd.
sprocketsoz.com.au

SPX Cooling Technologies, Inc.
www.spxcooling.com

Stock Drive Products/Sterling Instrument (SDP/SI)

250 DUFFY AVENUE
HICKSVILLE, NY 11801
Phone: (516) 328-3300
Fax: (516) 326-8827
sdp-sisupport@sdp-si.com
www.sdp-si.com

SEE OUR AD
P19

Supreme Gear Co.
www.supremegear.com

Tampa Armature Works- TAW
www.tawinc.com

TB Woods
www.tbwoods.com

Team Industries
www.team-ind.com

Thermoid
www.thermoid.com

Tolomatic, Inc.
www.tolomatic.com

Top Machinery & Equipment (Zhengzhou) Ltd
www.top-rol.com

Torque Transmission
www.torqueustrans.com

Transply Inc.
www.transply.com

Trojon Gear Inc.
www.trojon-gear.com

TSS Rotterdam B.V.
www.tssr.nl

Tsubaki of Canada Limited
www.tsubaki.ca

TVT America, Inc.
www.tvtamerica.com

U.S. Tsubaki
301 E. MARQUARDT DR.
WHEELING, IL 60090
Phone: (847) 459-9500
Fax: (847) 459-9515
sales@ustsubaki.com
www.ustsubaki.com

SEE OUR AD
P31

Vision International
www.engimech.com

Vision Quality Components, Inc
www.visionqci.com

VL Motion Systems Inc.
www.vlmotion.com

Voith Turbo Inc
voith.com/usa/en/index.html

Volta Belting
voltabelting.com

W.M. Berg
www.wmberg.com

Wajax
www.wajax.com

WJB Group
www.wjbgroup.com

WMH Transmissions Ltd
www.wmh-trans.co.uk

Yogi Bearings
www.yogibearings.com

York Industries
www.york-ind.com

Zeon Belts Pvt. Ltd.
www.zeonbelts.com

BRAKES

Affiliated Distributors
www.adhq.com

AIMS Industrial Supplies
www.aimsindustrial.com.au

Andantex USA Inc.
1705 VALLEY ROAD
WANAMASSA, NJ 07712
Phone: (732) 493-2812
Fax: (732) 493-2949
info@andantex.com
www.andantex.com

SEE OUR AD
P11

Applied Dynamics
www.applied-dynamics.com

Applied Power Solutions
apscorp.com

Area Distributors Inc.
aredist.com

BDI - Bearing Distributors Inc.
www.bdiexpress.com

Bearing Engineering Company
bearingengineering.com

Bearing Headquarters
www.bearingheadquarters.com

Beaver Aerospace and Defense Inc.
www.beaver-online.com

Bison Gear and Engineering Corp.
www.bisongear.com

ComInTec
www.comintec.com

Cryotron Magnadrives
www.cmdindia.com

Currie Enterprises
www.currieenterprises.com

Dalton Bearing Service, Inc.
www.daltonbearing.com

Dellner Brakes AB
www.dellner-brakes.com

Desch Canada Ltd.
www.desch.de

Dings Company
www.dingsbrakes.com

Drive Lines Technologies Ltd
www.drivelines.co.uk

Dunkermotoren USA Inc.
www.dunkermotoren.com

EIDE Industrial Clutches and Brakes
www.eide.net

Emco Dynatorq Pvt. Ltd.
www.emco-dynatorq.in

Engifield Engineering
engifield.com

Force Control

3660 DIXIE HIGHWAY
FAIRFIELD, OH 45014
Phone: (513) 868-0900
Fax: (513) 868-2105
info@forcecontrol.com
www.forcecontrol.com

SEE OUR AD
P17

Hoffmann Technics AG
www.hoffmann-tech.ch

I-MAK Reduktor

SANAYI CAD. NO:1 / SEYHLI - PENDIK
ISTANBUL 34000
TURKEY
Phone: +90 2163780326
Fax: +902163780686
export@imakreduktor.com
www.imakreduktor.com

SEE OUR AD
P69

IBT Industrial Solutions
www.ibtinc.com

IMS LLC
www.intermotionsupply.com

Industrial Friction Materials Ltd.
www.industrialfriction.com

Inertia Dynamics, Inc.
www.idicb.com

ISC Companies
isccompanies.com

Johnson Industries Ltd.
www.brakes.ca

JVL Industri Elektronik A/S
www.jvl.dk

KEB America, Inc.
keblog.com

Klam America
www.electricbrakesystems.com

Kraft Power Corporation
www.kraftpower.com

KTR Corporation
www.ktr.com/us

Lafert North America

5620 KENNEDY ROAD
MISSISSAUGA ON L4Z 2A9
CANADA
Phone: (905) 629-1939 or toll free (800) 661-6413
Fax: (905) 629-2852
sales@lafertna.com
www.lafertna.com

SEE OUR AD
P35

Logan Clutch Corp
www.loganclutch.com

Mach III Clutch Inc.
www.machiii.com

Magnetic Technologies Ltd
www.magnetictech.com

Magtrol, Inc.
www.magtrol.com

Marshall Wolf Automation Inc.
www.wolfautomation.com

Matrix International
www.matrix-international.com

Mayr Corporation
www.mayr.com

MES INC
www.mesinc.net

MICO, Incorporated
www.mico.com

Midwest Brake
www.midwestbrake.com

Midwest Motion Products
www.midwestmotion.com

Miki Pulley

13200 6TH AVENUE NORTH
PLYMOUTH, MN 55441
Phone: (800) 533-1731
Fax: (763) 546-8260
sales@mikipulley-us.com
www.mikipulley-us.com

SEE OUR AD
P38

Motion Industries
www.motionindustries.com

MPT Drives, Inc.
www.mptdrives.com

New Torque, Inc.
newtorque.com

Ningbo Zhongyi Hydraulic Motor Co. Ltd.
www.zihyd.com

Nordex, Inc.

426 FEDERAL ROAD
BROOKFIELD, CT 06804
Phone: 203-775-4877
Fax: 203-775-6552
sales@nordex.com
www.nordex.com

SEE OUR AD
P69

Northwest Electric Motor Company
northwestmotor.com

Novotec Argentina SRL
www.novotecargentina.com

Onvio LLC
www.onviollc.com

Orttech
www.orttech.com

Pethe Engineering Private Limited
www.pethe.in

PIC Design
www.pic-design.com

Precipart
www.precipart.com

Rexnord
www.rexnord.com

Ringspann Corporation
www.ringspanncorp.com

Rockwell Automation
www.rockwellautomation.com

SEPAC Inc
www.sepac.com

SIPCO

12610 GALVESTON ROAD
WEBSTER TX 77598
Phone: 2814808711
www.sipco-mls.com

SEE OUR AD
P69

Sprockets Australia Pty. Ltd.
sprocketsoz.com.au

SPX Cooling Technologies, Inc.
www.spxcooling.com

Stearns
www.stearnsbrakes.com

Stephenson Gobin Transmissions
www.sgtransmission.com

Stock Drive Products/Sterling Instrument (SDP/SI)

250 DUFFY AVENUE
HICKSVILLE, NY 11801
Phone: (516) 328-3300
Fax: (516) 326-8827
sdp-sisupport@sdp-si.com
www.sdp-si.com

SEE OUR AD
P19

Stoffel Polygon Systems, Inc.
www.stoffelpolygon.com

TB Wood's
www.tbwoods.com

Team Industries
www.team-ind.com

Thomson Industries Inc.
www.thomsonlinear.com

Tolomatic, Inc.
www.tolomatic.com

Transmission Machinery Co., Ltd
www.transcyko-transtec.com

Transply Inc.
www.transply.com

Turbo Couplings Co. Ltd.
www.turbokaplin.com.tr

TVT America, Inc.
www.tvtamerica.com

Twiflex Limited
www.twiflex.com

VL Motion Systems Inc.
www.vlmotion.com

Vortex Engineering Works
www.vortex-clutch.com

W.M. Berg
www.wmberg.com

Wajax
www.wajax.com

WPT Power Corporation
www.wptpower.com

CHAIN & CHAIN DRIVES

ABL Products Incorporated
www.ablproducts.com

ABM DRIVES INC.
abm-drives.us

ABT Bearing
www.abtbearing.com

Accent Bearings Co. Inc.
www.accentbearing.com

Accurate Gear and Machine, Inc.
accurategear.com

Acorn Industrial Services Ltd.
www.acorn-ind.co.uk

Affiliated Distributors
www.adhq.com

Agro Engineers
www.agroengineers.com

AIMS Industrial Supplies
www.aimsindustrial.com.au

Akron Gear and Engineering
www.akrongear.com

Ametric / American Metric Corporation
www.ametric.com

Area Distributors Inc.
areadist.com

Ascent Precision Gear Corporation
www.ascentgear.com

B&B Manufacturing, Inc.
www.bbman.com

B & R Machine and Gear Corp.

4809 U.S. HWY. 45
SHARON, TN 38255
Phone: (731) 456-2636 or (800) 238-0651
Fax: (731) 456-3073
inquiry@brgear.com
www.brgear.com

SEE OUR AD
P68

Baart Industrial Group
www.baartgroup.com

Bartlett Bearing Company, Inc.
www.bartlettbearing.com

BDI - Bearing Distributors Inc.
www.bdiexpress.com

Bearing Engineering Company
bearingengineering.com

Bearing Headquarters
www.bearingheadquarters.com

Bearings and Industrial Supply Company, Inc.
www.bearingsnow.com

Bearing Service Company
www.bearing-service.com

Bearings Limited
www.bearingslimited.com

Bishop-Wisecarver Corp.
www.bwc.com

BK Power Systems - An Integrated Corrosion Co.
www.bkpowersystems.com

Bonfiglioli USA, Inc.

3541 HARGRAVE DRIVE
HEBRON KY 41048
Phone: (859) 334-3333
Fax: (859) 334-8888
mbx-industrialsalesusa@bonfiglioli.com
www.Bonfiglioli.com

SEE OUR AD
P27,53

Bowman Hollis Mfg
www.bowmanhollis.com

Brewer Machine & Gear Co.
www.brewertensioner.com

C-B Gear & Machine, Inc.
www.cbgear.com

Central Gear & Machine
www.cgmatlanta.com

Challenge Power Transmission (Aust) Pty Ltd
www.challengept.com

Challenge Power Transmission PLC
www.challengept.com

Cloyes Gear & Products Inc.
www.cloyes.com

Cogmatic
www.cogmatic.com

Commercial Gear & Sprocket Co. Inc.
www.commercialgear.com

Cross + Morse
www.crossmorse.com

Daido Corporation of America
www.daidocorp.com

Dalton Bearing Service, Inc.
www.daltonbearing.com

Darbar Belting
www.darbarbelting.co.in

Davall Gears Ltd.
www.davall.com

Desch Canada Ltd.
www.desch.de

Diamond Chain Company
www.diamondchain.com

Distag QCS
www.distag.com

Electro Steel Engineering Company
www.fenner.in

Elliott Manufacturing
www.elliottmfg.com

Engifield Engineering
engifield.com

Ensinger Precision Components
www.plastockonline.com

First Gear Engineering & Technology
www.first-gear.com

Framo Morat Inc.
www.framo-morat.com

Gates Corporation
www.gates.com

Gayatri Gear Industries
www.gayatrigear.com

Gear Master Inc.
www.gearmaster.us

Gibbs Gears Precision Engineers
www.gibbsgears.com
Hangzhou Ocean Industry Co., Ltd.
www.hzoic.com
Hangzhou Xingda Machinery Co. Ltd.
www.xdmade.com

HVH Industrial Solutions
hvhindustrial.com

IBT Industrial Solutions
www.ibtinc.com

ISC Companies
isccompanies.com

Kamar Industries
www.kamarindustries.com

Kinematics Manufacturing, Inc.
www.kinematicsmtg.com

Lovejoy, Inc. (A Timken Brand)
www.lovejoy-inc.com

Machine Guard & Cover Co.
machineguard.com

Machinists Inc.
machinistsinc.com

Maguire Technologies
www.maguiretech.com

Malloy Electric
www.MalloyWind.com

Martin Sprocket & Gear
www.martinsprocket.com

Melfast
www.melfast.com

Metric & Multistandard Components Corp
www.metricmcc.com

MFG Components Oy
www.mfg.fi

Ming Chang Traffic Parts Mfg.
www.mccchain.com.tw

Motion Industries
www.motionindustries.com

Moventas Ltd.
www.moventas.com

MPT Drives, Inc.
www.mptdrives.com

MT Tool & Manufacturing
www.mttoolinc.com

Muratech Engineering Company
www.muracopower.co.in

Nordex, Inc.
426 FEDERAL ROAD
BROOKFIELD, CT 06804
Phone: 203-775-4877
Fax: 203-775-6552
sales@nordex.com
www.nordex.com

SEE OUR AD
P69

Nu-Teck Couplings Pvt. Ltd
www.nuteckcouplings.com

Orbitless Drives, Inc
www.orbitless.com

P.T. International Corp. (PTI)
www.ptintl.com

Pacific Industries
www.pacificindustries.com

PEER Chain
www.peerchain.com

Performance Gear Systems, Inc.
www.performance-gear.com

PIC Design
www.pic-design.com

Pix Transmissions Limited
www.pixtrans.com

Plastock - Putnam Precision Molding, Inc.
www.plastockonline.com

PowerDrive LLC
www.powerdrive.com

Pulley Manufacturers International Inc.
www.pulleys.com

RBI Bearing Inc.
101 S. GARY AVE., STE. B
ROSELLE IL 60172
Phone: 800-708-2128
Fax: (630) 295-5490
info@rbibearing.com
www.rbibearing.com

SEE OUR AD
P5

Regal
200 STATE STREET
BELOIT WI 53511
Phone: 800-626-2120
Fax: (800) 262-3292
Ian.Rubin@regalbeloit.com
www.regalbeloit.com

SEE OUR AD
P13

René Baer AG
www.renebaerag.ch

Renold Jeffrey
www.renoldjeffrey.com

Rexnord
www.rexnord.com

Ringball Corporation
www.ringball.com

Rockwell Automation
www.rockwellautomation.com

Serapid Inc.
www.serapid.us

Shijiazhuang CAPT Power Transmission Co., Ltd
www.chssb.com

Sichuan Mighty Machinery Co. Ltd.
www.sc-mighty.com

Silcoms Ltd
www.silcoms.com/conveyor-chain-division/

SKF USA Inc.
www.skf.com

Snow Nabstedt Power Transmissions Inc
www.snpt.biz

Special Ingranaggi
www.specialingranaggi.com/en/

Sprockets Australia Pty. Ltd.
sprocketsoz.com.au

ST Gear & Machine LLC
www.stgearandmachine.com

Stock Drive Products/Sterling Instrument (SDP/SI)
250 DUFFY AVENUE
HICKSVILLE, NY 11801
Phone: (516) 328-3300
Fax: (516) 326-8827
sdp-sisupport@sdp-si.com
www.sdp-si.com

SEE OUR AD
P19

Team Industries
www.team-ind.com

Torque Transmission
www.torquetrans.com

Transply Inc.
www.transply.com

Trojon Gear Inc.
www.trojon-gear.com

Tsubaki of Canada Limited
www.tsubaki.ca

TVT America, Inc.
www.tvtamerica.com

U.S. Tsubaki
301 E. MARQUARDT DR.
WHEELING, IL 60090
Phone: (847) 459-9500
Fax: (847) 459-9515
sales@ustsubaki.com
www.ustsubaki.com

SEE OUR AD
P31

VL Motion Systems Inc.
www.vlmotion.com

Wajax
www.wajax.com

WJB Group
www.wjbgroup.com

WMH Transmissions Ltd
www.wmh-trans.co.uk

Yogi Bearings
www.yogibeatings.com

York Industries
www.york-ind.com

CLUTCHES

Accent Bearings Co. Inc.
www.accentbearing.com

Affiliated Distributors
www.adhq.com

AISCO Industrial Couplings
www.aiscoinc.com

Andantex USA Inc.
1705 VALLEY ROAD
WANAMASSA, NJ 07712
Phone: (732) 493-2812
Fax: (732) 493-2949
info@andantex.com
www.andantex.com

SEE OUR AD
P11

Applied Power Solutions
apscorp.com

Area Distributors Inc.
areadist.com

Ascent Precision Gear Corporation
www.ascentgear.com

ATO Inc
www.ato.com

Bearing Boys Ltd
www.bearingboys.co.uk

Bearing Engineering Company
bearingengineering.com

Bearing Headquarters
www.bearingheadquarters.com

Bearing Service Company
www.bearing-service.com

Bibby Turboflex
www.bibbyturboflex.com

BK Power Systems - An Integrated Corrosion Co.
www.bkpowersystems.com

Boston Gear
www.bostongear.com

Cabat Inc.
www.cabatinc.com

CENTA Power Transmission
www.centa.info

ComInTec
www.comintec.com

Commercial Gear & Sprocket Co. Inc.
www.commercialgear.com

Cross + Morse
www.crossmorse.com

Cryotron Magnadrives
www.cmdindia.com

Dalton Bearing Service, Inc.
www.daltonbearing.com

Davall Gears Ltd.
www.davall.com

Dendoff Springs
www.Dendoff.com

Desch Canada Ltd.
www.desch.de

DieQua Corp.
180 COVINGTON DRIVE
BLOOMINGDALE, IL 60108
Phone: (630) 980-1133
Fax: (630) 980-1232
info@diequa.com
www.diequa.com

SEE OUR AD
P28,69

Drive Lines Technologies Ltd
www.drivelines.co.uk

Dynatet Manufacturing Inc. (fka A & A Mfg.)
www.dynatet.com

EIDE Industrial Clutches and Brakes
www.eide.net

Emco Dynatorq Pvt. Ltd.
www.emco-dynatorq.in

Engfield Engineering
engfield.com

Flux Drive Inc.
www.fluxdrive.com

Force Control

3660 DIXIE HIGHWAY
FAIRFIELD, OH 45014
Phone: (513) 868-0900
Fax: (513) 868-2105
info@forcecontrol.com
www.forcecontrol.com

SEE OUR AD
P17

Formsprag Clutch
www.formsprag.com

Ghatge Patil Industries
www.gpi.co.in

GMN Bearing USA, Ltd.
www.gmnbearing.com

Howdon Power Transmission Limited
www.howdon.com

Huco Dynatork
www.huco.com

IBT Industrial Solutions
www.ibtinc.com

Industrial Friction Materials Ltd.
www.industrialfriction.com

Inertia Dynamics, Inc.
www.idicb.com

ISC Companies
isccompanies.com

J.W. Winco Inc.
www.jwwinco.com

jbj Techniques Limited
www.jbj.co.uk

KBK Antriebstechnik GmbH
www.kbk-antriebstechnik.de

KEB America, Inc.
kebblog.com

Kraft Power Corporation
www.kraftpower.com

KTR Corporation
www.ktr.com/us

Logan Clutch Corp
www.loganclutch.com

Mach III Clutch Inc.
www.machiii.com

Machinists Inc.
machinistsinc.com

Magnetic Technologies Ltd
www.magnetictech.com

Magtrol, Inc.
www.magtrol.com

Malloy Electric
www.MalloyWind.com

Marine Specialties, Inc.
www.marinespecialties-inc.com

Marshall Wolf Automation Inc.
www.wolfautomation.com

Matrix International
www.matrix-international.com

Mayr Corporation
www.mayr.com

Means Industries, Inc.
www.meansindustries.com

MES INC
www.mesinc.net

Midwest Brake
www.midwestbrake.com

Miki Pulley

13200 6TH AVENUE NORTH
PLYMOUTH, MN 55441
Phone: (800) 533-1731
Fax: (763) 546-8260
sales@mikipulley-us.com
www.mikipulley-us.com

SEE OUR AD
P38

Motion Industries
www.motionindustries.com

Moventas Ltd.
www.moventas.com

MPT Drives, Inc.
www.mptdrives.com

Mubea
www.mubea-discsprings.com

New Torque, Inc.
newtorque.com

Nordex, Inc.

426 FEDERAL ROAD
BROOKFIELD, CT 06804
Phone: 203-775-4877
Fax: 203-775-6552
sales@nordex.com
www.nordex.com

SEE OUR AD
P69

North American Clutch & Driveline
www.naclutch.com

Novotec Argentina SRL
www.novotecargentina.com

Ondrives US Corp.
www.ondrivesus.com

Orttech
www.orttech.com

Pethe Engineering Private Limited
www.pethe.in

PIC Design
www.pic-design.com

Precipart
www.precipart.com

R+W America

254 TUBEWAY DRIVE
CAROL STREAM, IL 60188
Phone: (630) 521-9911
Fax: (630) 521-0366
info@rw-america.com
www.rw-america.com

SEE OUR AD
P7

Regal

200 STATE STREET
BELOIT WI 53511
Phone: 800-626-2120
Fax: (800) 262-3292
Ian.Rubin@regalbeloit.com
www.regalbeloit.com

SEE OUR AD
P13

René Baer AG
www.renebaerag.ch

Renold
www.renold.com

Rexnord
www.rexnord.com

Ringfeder Power Transmission USA Corp.
www.ringfeder.com

Ringspann Corporation
www.ringspanncorp.com

Rockwell Automation
www.rockwellautomation.com

Rolling Motion Industries
www.rmidrive.com

SBT Gearing Solutions
sbt-gears.co.uk

SEPAC Inc
www.sepac.com

Snow Nabstedt Power Transmissions Inc
www.snpt.biz

Sprockets Australia Pty. Ltd.
sprocketsoz.com.au

SPX Cooling Technologies, Inc.
www.spxcooling.com

SSS Clutch Company
www.sssclutch.com

Stearns
www.stearnsbrakes.com

The Steel Plate & Component Factory
www.steelplates.in

Stephenson Gobin Transmissions
www.sgttransmission.com

Stieber Clutch
www.stieberclutch.com

Stock Drive Products/Sterling Instrument (SDP/SI)

250 DUFFY AVENUE
HICKSVILLE, NY 11801
Phone: (516) 328-3300
Fax: (516) 326-8827
sdp-sisupport@sdp-si.com
www.sdp-si.com

SEE OUR AD
P19

Supreme Gear Co.
www.supremegear.com

TB Wood's
www.tbwoods.com

Team Industries
www.team-ind.com

Thomson Industries Inc.
www.thomsonlinear.com

Tolomatic, Inc.
www.tolomatic.com

Transply Inc.
www.transply.com

TVT America, Inc.
www.tvtamerica.com

Twiflex Limited
www.twiflex.com

VL Motion Systems Inc.
www.vlmotion.com

Vortex Engineering Works
www.vortex-clutch.com

W.M. Berg
www.wmberg.com

Wajax
www.wajax.com

WPT Power Corporation
www.wptpower.com

CONTROLS

ABB Motors and Mechanical Inc.
www.baldor.com

ABM DRIVES INC.
abm-drives.us

Ace World Companies
www.aceworldcompanies.com

ACS Motion Control
www.acsmotioncontrol.com

Advanced Control Systems Corporation
www.acsmotion.com

Aerotech Inc.
www.aerotech.com

Affiliated Distributors
www.adhq.com

Allied International
www.alliedinter.com

Allied Motion
www.alliedmotion.com

American Rotary Phase Converters
www.americanrotary.com

Anaheim Automation, Inc.
www.anaheimautomation.com

Applied Dynamics
www.applied-dynamics.com

Applied Power Solutions
apscorp.com

Area Distributors Inc.
areadist.com

ATO Inc
www.ato.com

Automation Direct
www.automationdirect.com

Axu s.r.l.
www.axu.it

BDI - Bearing Distributors Inc.
www.bdiexpress.com

Bearing Engineering Company
bearingengineering.com

Bearing Headquarters
www.bearingheadquarters.com

Bearing Service Company
www.bearing-service.com

Binsfeld Engineering Inc.
www.binsfeld.com

BK Power Systems - An Integrated Corrosion Co.
www.bkpowersystems.com

Bodine Electric Company
www.bodine-electric.com

Bonfiglioli Riduttori S.p.A.
www.bonfiglioli.com

Bonfiglioli USA, Inc.

3541 HARGRAVE DRIVE
HEBRON KY 41048
Phone: (859) 334-3333
Fax: (859) 334-8888
mbx-industrialsalesusa@bonfiglioli.com
www.Bonfiglioli.com

SEE OUR AD
P27,53

Bosch Rexroth
www.boschrexroth-us.com

Boston Gear
www.bostongear.com

CNC Center
www.cnccenter.com

Control Switches International Inc
www.controlswitches.com

Cutes Corporation
www.cutes.com.tw

Dalton Bearing Service, Inc.
www.daltonbearing.com

Dellner Brakes AB
www.dellner-brakes.com

DieQua Corp.
180 COVINGTON DRIVE
BLOOMINGDALE, IL 60108
Phone: (630) 980-1133
Fax: (630) 980-1232
info@diequa.com
www.diequa.com

SEE OUR AD
P28,69

Dongyang Anuze Motor Smartech Co. Ltd.
www.microgearmotor.com

Dover Motion
www.dovermotion.com

Drive Lines Technologies Ltd
www.drivelines.co.uk

Duff-Norton
www.duffnorton.com

Dunkermotoren USA Inc.
www.dunkermotoren.com

Dynamic Structures and Materials, LLC
www.dynamic-structures.com

Eagle PLC
www.eagleplc.com

Electronic Machine Parts
www.empregister.com

Emerson Industrial Automation - Drives & Motor
www.emerson.com/en-us/automation-solutions

Engifield Engineering
engifield.com

EquipNet
www.equipnet.com

Festo Corporation
www.festo.com/usa

Flux Drive Inc.
www.fluxdrive.com

Force Control

3660 DIXIE HIGHWAY
FAIRFIELD, OH 45014
Phone: (513) 868-0900
Fax: (513) 868-2105
info@forcecontrol.com
www.forcecontrol.com

SEE OUR AD
P17

FSI Technologies Inc.
www.fsinet.com

GoHz Power Supply Inc
www.gohz.com

Hallmark Industries Inc.
www.hallmarkind.com

Hansen Corporation
www.hansen-motor.com

Heidenhain Corporation
www.heidenhain.com

Hoffmann Technics AG
www.hoffmann-tech.ch

HPB Motion Control Co. Ltd.
www.hpb-industry.com

I-MAK Reduktor

SANAYI CAD. NO:1 / SEYHLI - PENDIK
ISTANBUL 34000
TURKEY
Phone: +90 2163780326
Fax: +902163780686
export@imakreduktor.com
www.imakreduktor.com

SEE OUR AD
P69

IBT Industrial Solutions
www.ibtinc.com

Industrial Automation Co.
www.industrialautomation.co

Inertia Dynamics, Inc.
www.idicb.com

Intellidrives, Inc
www.intellidrives.com

ISC Companies
isccompanies.com

JIE Drives

493 MISSION STREET
CAROL STREAM, IL 60188
Phone: (630) 580-9986
info@jie-drives.com
jie-drives.com

SEE OUR AD
P67

Johnson Industries Ltd.
www.brakes.ca

JVL Industri Elektronik A/S
www.jvl.dk

K+S Services
www.k-and-s.com

KB Controls
www.kb-controls.com

KEB America, Inc.
keblog.com

Kinematics Manufacturing, Inc.
www.kinematicsmfg.com

Kollmorgen
www.kollmorgen.com

Leeson Electric
www.leeson.com

Lenze Americas
www.lenze.com

Logan Clutch Corp
www.loganclutch.com

Magtrol, Inc.
www.magtrol.com

Malloy Electric
www.MalloyWind.com

Marshall Wolf Automation Inc.
www.wolfautomation.com

Mavilor Motors, S.a.
www.mavilor.es

Maxcess
www.maxcessintl.com

Maxon Precision Motors
www.maxonmotorusa.com

MICO, Incorporated
www.mico.com

Micronor Inc.
www.micronor.com

Midwest Motion Products
www.midwestmotion.com

Mitsubishi Electric Automation, Inc.
us.mitsubishielectric.com/fa/en

Modicon PLC
www.modiconplc.com

Molon Motor and Coil
300 NORTH RIDGE AVE.
ARLINGTON HEIGHTS, IL 60005
Phone: (847) 253-6000
Fax: (847) 259-0299
www.molon.com

SEE OUR AD
P41

MOONS' Industries
www.moonsindustries.com

Motion Industries
www.motionindustries.com

MPT Drives, Inc.
www.mptdrives.com

MRO Electric and Supply
www.mroelectric.com

MROS Supply
www.mrosupply.com

New Power Electric (USA) LLC
www.usa-newpower.com

New Torque, Inc.
newtorque.com

Nichiei Company, Ltd.

54 TOMAHAWK TRAIL
SPARTA, NEW JERSEY 07871
Phone: 973-729-2355
lizgershon@att.net
www.nichiei-ind.com/english/index.html

SEE OUR AD
P59

Northwest Electric Motor Company
northwestmotor.com

Novotec Argentina SRL
www.novotecargentina.com

Onvio LLC
www.onviollc.com

Ormec
www.ormec.com

Parker Hannifin SSD Drives Div.
www.parker.com/ssdusa

Phytron, Inc.
www.phytron.com

PI (Physik Instrumente) L.P. Piezo Actuator Nano
www.pi-usa.us

Potomac Electric
www.potomacelectric.com

Power Electric
www.powerelectric.com

Power Inverter Inc.
www.powerinverter.org

Power Jack Motion
www.powerjackmotion.com

Precipart
www.precipart.com

Rae DC Products Group
www.raemotors.com

Regent Controls, Inc
www.regentcontrols.com

Rockwell Automation
www.rockwellautomation.com

Rocky Mountain Technologies
www.rockymountaintechnologies.com

Sensata Technologies
www.sensata.com

Sesame Motor Corp.
www.sesamemotor.com.tw

SEW-Eurodrive

1295 OLD SPARTANBURG HWY.
P.O. BOX 518
LYMAN, SC 29635
Phone: (864) 439-7537
Fax: (864) 439-7830
www.seweurodrive.com

SEE OUR AD
IBC

Siemens Industry, Inc.
www.usa.siemens.com/industry/us/en

SIPCO

12610 GALVESTON ROAD
WEBSTER TX 77598
Phone: 2814808711
www.sipco-mls.com

Siti Spa Riduttori
www.sitiriduttori.it

SKF USA Inc.
www.skf.com

Source Engineering Inc.
www.sei-automation.com

SPX Cooling Technologies, Inc.
www.spxcooling.com

Stearns
www.stearnsbrakes.com

STM Riduttori SpA
www.stmspa.com

Tampa Armature Works- TAW
www.tawinc.com

Tapeswitch Corporation
www.tapeswitch.com

Team Industries
www.team-ind.com

Teco Westinghouse
www.tecowestinghouse.com

TelcoMotion
www.telcointercon.com

Thomson Industries Inc.
www.thomsonlinear.com

Tolomatic, Inc.
www.tolomatic.com

Transmission Machinery Co., Ltd
www.transcyko-transtec.com

Transply Inc.
www.transply.com

TVT America, Inc.
www.tvtamerica.com

Twiflex Limited
www.twiflex.com

U.S. Tsubaki

301 E. MARQUARDT DR.
WHEELING, IL 60090
Phone: (847) 459-9500
Fax: (847) 459-9515
sales@ustsubaki.com
www.ustsubaki.com

Varitron Engineering (Taiwan) Co., Ltd
www.c-var.com

VL Motion Systems Inc.
www.vlmotion.com

Voltage Converter Company
www.voltconverter.com

W.M. Berg
www.wmberg.com

Wajax
www.wajax.com

WEG
www.weg.net

WorldWide Electric Corporation

3540 WINTON PLACE
ROCHESTER NY 14623
Phone: 800-808-2131
Fax: 800-711-1616
customerservice@worldwideelectric.net
www.worldwideelectric.net

Yaskawa America, Inc.
www.yaskawa.com

COUPLINGS & U-JOINTS

Accent Bearings Co. Inc.
www.accentbearing.com

Accurate Gear and Machine, Inc.
accurategear.com

Acorn Industrial Services Ltd.
www.acorn-ind.co.uk

SEE OUR AD
P69

Affiliated Distributors
www.adhq.com

AGI Automation Components
www.agi-automation.com

Agro Engineers
www.agroengineers.com

AIMS Industrial Supplies
www.aimsindustrial.com.au

AISCO Industrial Couplings
www.aiscoinc.com

Ameridrives
www.ameridrives.com

Ametric / American Metric Corporation
www.ametric.com

AmTech International
www.amtechinternational.com

Applied Dynamics
www.applied-dynamics.com

Applied Power Solutions
apscorp.com

Area Distributors Inc.
areadist.com

Artec Machine Systems
www.artec-machine.com

Ascent Precision Gear Corporation
www.ascentgear.com

Atlanta Gear Works
www.atlantagear.com

Axu s.r.l.
www.axu.it

B & R Machine and Gear Corp.

4809 U.S. HWY. 45
SHARON, TN 38255
Phone: (731) 456-2636 or (800) 238-0651
Fax: (731) 456-3073
inquiry@brgear.com
www.brgear.com

SEE OUR AD
P68

Baart Industrial Group
www.baartgroup.com

Baker Bearing Company
www.bakerbearing.com

Bartlett Bearing Company, Inc.
www.bartlettbearing.com

BDI - Bearing Distributors Inc.
www.bdiexpress.com

Bearing Engineering Company
bearingengineering.com

Bearing Headquarters
www.bearingheadquarters.com

Bearings and Industrial Supply Company, Inc.
www.bearingsnow.com

Bearing Service Company
www.bearing-service.com

Belden Universal
www.beldenuiversal.com

BellowsTech, LLC
www.bellowstech.com

Bervina Ltd.
www.bervina.com

Bevel Gears India Pvt. Ltd.
bevelgearsindia.com

Bibby Turboflex
www.bibbyturboflex.com

BK Power Systems - An Integrated Corrosion Co.
www.bkpowersystems.com

Boneng Transmission USA LLC
www.boneng.com/English

Boston Gear
www.bostongear.com

BRECOflex CO., L.L.C.
www.brecoflex.com

BSF, Inc.
www.bsfinc.net

C-B Gear & Machine, Inc.
www.cbgear.com

C-Flex Bearing Co., Inc.
www.c-flex.com

Cabat Inc.
www.cabatinc.com

Canto Engineering Company
www.cantoengineering.com

CCTY Bearing
www.CCTYBearing.com

CENTA Power Transmission
www.centa.info

Cestari Industrial e Comercial S.A.
www.cestari.com.br

Challenge Power Transmission (Aust) Pty Ltd
www.challengept.com

Challenge Power Transmission PLC
www.challengept.com

Chengdu Talent Industrial Co., Ltd.
www.tlindustrial.com

ComInTec
www.comintec.com

Commercial Gear & Sprocket Co. Inc.
www.commercialgear.com

Cross + Morse
www.crossmorse.com

C R Products Ltd.
www.c-rproducts.com

Custom Machine & Tool Co. Inc.
www.cmtco.com

Dalton Bearing Service, Inc.
www.daltonbearing.com

Davall Gears Ltd.
www.davall.com

David Brown Santasalo
www.dbsantasalo.com

David Brown Santasalo Canada Service Inc.
www.dbsantasalo.com

DePe Gear Company Ltd
www.depe.co.uk

Desch Canada Ltd.
www.desch.de

Diaphragm Direct
www.diaphragmdirect.com

DieQua Corp.

180 COVINGTON DRIVE
BLOOMINGDALE, IL 60108
Phone: (630) 980-1133
Fax: (630) 980-1232
info@diequa.com
www.diequa.com

SEE OUR AD
P28,69

Distag QCS
www.distag.com

Dorris Gear Drives
DorrisCo.com

Drive Lines Technologies Ltd
www.drivelines.co.uk

Duff Norton Australia
www.duffnorton.com.au

EIDE Industrial Clutches and Brakes
www.eide.net

Electro Steel Engineering Company
www.fenner.in

Elkem Silicones
www.silicones.elkem.com

Elliott Manufacturing
www.elliottmfg.com

Flexcon Engineers Private Limited
www.flexconindia.com

Flux Drive Inc.
www.fluxdrive.com

Formsprag Clutch
www.formsprag.com

G.L. Huyett
www.huyett.com

GAM Enterprises
www.gamweb.com

Gayatri Gear Industries
www.gayatrigeart.com

Gear Master Inc.
www.gearmaster.us

Ghatge Patil Industries
www.gpi.co.in

Gibbs Gears Precision Engineers
www.gibbsgears.com

Gleason Plastic Gears
www.gleasonplasticgears.com

Hangzhou Ocean Industry Co., Ltd.
www.hzoic.com

Hangzhou Xingda Machinery Co. Ltd.
www.xdmade.com

Hayes Manufacturing Inc.
hayescouplings.com

Hi-Grade Inc.
www.higradeinc.com

Houston Pump and Gear
www.houstonpumpandgear.com

Huco Dynatork
www.huco.com

HVH Industrial Solutions
hvhindustrial.com

IBT Industrial Solutions
www.ibtinc.com

Industrial Spares Manufacturing Co.
www.industrialsparesfromindia.com

Inertia Dynamics, Inc.
www.idicb.com

Involute Powergear Pvt. Ltd.
www.involutetools.com

ISC Companies
isccompanies.com

jbj Techniques Limited
www.jbj.co.uk

KBK Antriebstechnik GmbH
www.kbk-antriebstechnik.de

Kinematics Manufacturing, Inc.
www.kinematicsmfg.com

Kraft Power Corporation
www.kraftpower.com

KTR Corporation
www.ktr.com/us

Logan Clutch Corp
www.loganclutch.com

Lovejoy, Inc. (A Timken Brand)
www.lovejoy-inc.com

Mach III Clutch Inc.
www.machiii.com

Machinists Inc.
machinistsinc.com

Magnetic Technologies Ltd
www.magnetictech.com

Malloy Electric
www.MalloyWind.com

Marine Specialties, Inc.
www.marinespecialties-inc.com

Martin Sprocket & Gear
www.martinsprocket.com

Master Bond, Inc.
www.masterbond.com

MasterDrive, Inc.
www.masterdrives.com

Matrix International
www.matrix-international.com

Maurey Manufacturing Corporation
www.maurey.biz

MAV S.p.A.
www.mav.it

Mayr Corporation
www.mayr.com

MES INC
www.mesinc.net

MFG Components Oy
www.mfg.fi

Miki Pulley
13200 6TH AVENUE NORTH
PLYMOUTH, MN 55441
Phone: (800) 533-1731
Fax: (763) 546-8260
sales@mikipulley-us.com
www.mikipulley-us.com

SEE OUR AD
P38

Minsk Gear Works
www.mgw.by

Mitsuboshi Belting LTD/MBL (USA) Corp
www.mblusa.com

Motion Industries
www.motionindustries.com

Moventas Ltd.
www.moventas.com

MPT Drives, Inc.
www.mptdrives.com

Muratech Engineering Company
www.muracopower.co.in

NDE Power Transmissions
www.ndepower.com

Netshape Technologies, Inc.
www.netshapetech.com

New Power Electric (USA) LLC
www.usa-newpower.com

Nordex, Inc.
426 FEDERAL ROAD
BROOKFIELD, CT 06804
Phone: 203-775-4877
Fax: 203-775-6552
sales@nordex.com
www.nordex.com

SEE OUR AD
P69

Novotec Argentina SRL
www.novotecargentina.com

Nu-Teck Couplings Pvt. Ltd
www.nuteckcouplings.com

OEP Couplings, a Division of Oren Elliott Products
www.oepcouplings.com

Ondrives US Corp.
www.ondrivesus.com

Orttech
www.orttech.com

P.T. International Corp. (PTI)
www.ptintl.com

Pacific Industries
www.pacificindustries.com

PIC Design
www.pic-design.com

Pinpoint Laser Systems
pinpointlaser.com

Pix Transmissions Limited
www.pixtrans.com

PowerDrive LLC
www.powerdrive.com

R+W America
254 TUBEWAY DRIVE
CAROL STREAM, IL 60188
Phone: (630) 521-9911
Fax: (630) 521-0366
info@rw-america.com
www.rw-america.com

SEE OUR AD
P7

Regal
200 STATE STREET
BELOIT WI 53511
Phone: 800-626-2120
Fax: (800) 262-3292
lan.Rubin@regalbeloit.com
www.regalbeloit.com

SEE OUR AD
P13

René Baer AG
www.renebaerag.ch

Renold
www.renold.com

Rexnord
www.rexnord.com

RGW Sales Canada
www.rgwsalescanada.com

Ringball Corporation
www.ringball.com

Ringfeder Power Transmission USA Corp.
www.ringfeder.com

Ringspann Corporation
www.ringspanncorp.com

Rubena a.s.
www.rubena.cz

Ruland Manufacturing Co., Inc.
www.ruland.com

SEPAC Inc
www.sepac.com

Servometer
www.servometer.com

Shanghai Shine Transmission Machinery Co. Ltd.
www.syptworld.com

Shijiazhuang CAPT Power Transmission Co., Ltd
www.chssb.com

Shreecon Gear
shreecongear.com

Sichuan Mighty Machinery Co. Ltd.
www.sc-mighty.com

Siemens Industry, Inc.
www.usa.siemens.com/industry/us/en

SIPCO
12610 GALVESTON ROAD
WEBSTER TX 77598
Phone: 2814808711
www.sipco-mls.com

SEE OUR AD
P69

SKF USA Inc.
www.skf.com

Southern Gear & Machine
www.southerngear.net

Sprockets Australia Pty. Ltd.
sprocketsoz.com.au

SPX Cooling Technologies, Inc.
www.spxcooling.com

Stock Drive Products/Sterling Instrument (SDP/SI)
250 DUFFY AVENUE
HICKSVILLE, NY 11801
Phone: (516) 328-3300
Fax: (516) 326-8827
sdp-sisupport@sdp-si.com
www.sdp-si.com

SEE OUR AD
P19

Stoffel Polygon Systems, Inc.
www.stoffelpolygon.com

Supreme Gear Co.
www.supremegear.com

TB Wood's
www.tbwoods.com

Team Industries
www.team-ind.com

Tien Yi Gear Works Co., Ltd
www.tienyigear.com.tw

Timothy Holding Co., Ltd.
www.timothyholding.com

Transmission Machinery Co., Ltd
www.transcyko-transtec.com

Transply Inc.
www.transply.com

TSS Rotterdam B.V.
www.tssr.nl

Tsubaki of Canada Limited
www.tsubaki.ca

Turbo Couplings Co. Ltd.
www.turbokaplin.com.tr

TVT America, Inc.
www.tvtamerica.com

Twiflex Limited
www.twiflex.com

**Twin Spring Coupling LLC**

226 BLAUVELT ROAD
PEARL RIVER, NY 10965
Phone: 7189381950
Fax: 8459201258
darrenf@twinspringcoupling.com
www.twinspringcoupling.com

SEE OUR AD
P52**U.S. Tsubaki**

301 E. MARQUARDT DR.
WHEELING, IL 60090
Phone: (847) 459-9500
Fax: (847) 459-9515
sales@ustsubaki.com
www.ustsubaki.com

SEE OUR AD
P31

Venture Mfg. Co.
www.venturemfgco.com

Vision International
www.engimech.com

Vision Quality Components, Inc
www.visionqci.com

VL Motion Systems Inc.
www.vlmotion.com

Voith Turbo Inc
voith.com/usa/en/index.html

W.M. Berg
www.wmberg.com

Wajax
www.wajax.com

Wellman Wacoma Limited
www.wellmanwacoma.com

Wittenstein
www.wittenstein-us.com

WMH Transmissions Ltd
www.wmh-trans.co.uk

Xtek, Inc.
www.xtek.com

Yogi Bearings
www.yogibearings.com

York Industries
www.york-ind.com

Zero-Max

13200 SIXTH AVENUE NORTH
MINNEAPOLIS, MN 55441
Phone: (763) 546-4300
Fax: (763) 546-8260
sales@zero-max.com
www.zero-max.com

SEE OUR AD
P89

ZRIME
www.zrime.com.cn

FLUID POWER

Acorn Industrial Services Ltd.
www.acorn-ind.co.uk

Affiliated Distributors
www.adhq.com

AIMS Industrial Supplies
www.aimsindustrial.com.au

AmTech International
www.amtechinternational.com

Andec Mfg. Ltd.
www.andec.ca

Applied Dynamics
www.applied-dynamics.com

ATO Inc
www.ato.com

BDI - Bearing Distributors Inc.
www.bdiexpress.com

Bearing Engineering Company
bearingengineering.com

Bearing Headquarters
www.bearingheadquarters.com

Bearings and Industrial Supply Company, Inc.
www.bearingsnow.com

BK Power Systems - An Integrated Corrosion Co.
www.bkpowersystems.com

Bonfiglioli USA, Inc.

3541 HARGRAVE DRIVE
HEBRON KY 41048
Phone: (859) 334-3333
Fax: (859) 334-8888
mbx-industrialsalesusa@bonfiglioli.com
www.Bonfiglioli.com

SEE OUR AD
P27,53

Bosch Rexroth
www.boschrexroth-us.com

CENTA Power Transmission
www.centa.info

Cone Drive
www.conedrive.com

Cotta Transmission Co. LLC
cotta.com

Dalton Bearing Service, Inc.
www.daltonbearing.com

Dongyang Anuze Motor Smartech Co. Ltd.
www.microgearmotor.com

Dynex/Rivett Inc.
www.dynexhydraulics.com

Elkem Silicones
www.silicones.elkem.com

Filter Pumper / Hydraulic Problems, Inc.
www.filterpumper.com

Friel Metal Resurfacing
www.frielmetalresurfacing.com

G.L. Huyett
www.huyett.com

GoHz Power Supply Inc
www.gohz.com

Hayes Manufacturing Inc.
hayescouplings.com

Hidrax
www.hidrax.eu/en/

Houston Pump and Gear
www.houstonpumpandgear.com

IBT Industrial Solutions
www.ibtinc.com

ISC Companies
isccompanies.com

jbj Techniques Limited
www.jbj.co.uk

K+S Services
www.k-and-s.com

KTR Corporation
www.ktr.com/us

Logan Clutch Corp
www.loganclutch.com

Lovejoy, Inc. (A Timken Brand)
www.lovejoy-inc.com

MICO, Incorporated
www.mico.com

Motion Industries
www.motionindustries.com

Netshape Technologies, Inc.
www.netshapetech.com

NGT Specialty Valves
www.ngtvalves.com

Ningbo Zhongyi Hydraulic Motor Co. Ltd.
www.zihyd.com

OEM International Inc.
www.oeminternational.com

Orttech
www.orttech.com

Precision Pump and Gear Works
www.ppg-works.com

Regal

200 STATE STREET
BELOIT WI 53511
Phone: 800-626-2120
Fax: (800) 262-3292
Ian.Rubin@regalbeloit.com
www.regalbeloit.com

SEE OUR AD
P13

RGW Sales Canada
www.rgwsalescanada.com

Rubena a.s.
www.rubena.cz

S.M. Shah & Company
hydraulicvanepump.com

Shijiazhuang CAPT Power Transmission Co., Ltd
www.chssb.com

Souz Vacuum
www.souzvac.com

Techtop Industries, Inc.
www.techttopind.com

Tef Cap Industries Inc.
www.tefcap.com

TSS Rotterdam B.V.
www.tssr.nl

Turbo Couplings Co. Ltd.
www.turbokaplin.com.tr

TVT America, Inc.
www.tvtamerica.com

Var-Spe Variatori Oleodinamici
www.varspe.com

Voith Turbo Inc
voith.com/usa/en/index.html

Wajax
www.wajax.com

WorldWide Electric Corporation

3540 WINTON PLACE
ROCHESTER NY 14623
Phone: 800-808-2131
Fax: 800-711-1616
customerservice@worldwideelectric.net
www.worldwideelectric.net

SEE OUR AD
P12**Zero-Max**

13200 SIXTH AVENUE NORTH
MINNEAPOLIS, MN 55441
Phone: (763) 546-4300
Fax: (763) 546-8260
sales@zero-max.com
www.zero-max.com

SEE OUR AD
P89**GEAR DRIVES**

ABB Motors and Mechanical Inc.
www.baldor.com

ABM DRIVES INC.
abm-drives.us

Accent Bearings Co. Inc.
www.accentbearing.com

Accurate Gear and Machine, Inc.
accurategear.com

Ace World Companies
www.aceworldcompanies.com

Acme Gear Co.
www.acmegear.com

Acorn Industrial Services Ltd.
www.acorn-ind.co.uk

Aero Gear Inc.
aerogear.com

Affiliated Distributors
www.adhq.com

Agnee Transmissions (I) Pvt Ltd
www.agneetransmissions.com

Agro Engineers
www.agroengineers.com

Akgears, LLC
www.akgears.com

Akron Gear and Engineering
www.akrongear.com

Allied Motion
www.alliedmotion.com

American Gear & Engineering
www.americangear.net

Ametric / American Metric Corporation
www.ametric.com

AmTech International
www.amtechinternational.com

Ancon Gear & Instrument Corp.
www.ancongear.com

Andantex USA Inc.
1705 VALLEY ROAD
WANAMASSA, NJ 07712
Phone: (732) 493-2812
Fax: (732) 493-2949
info@andantex.com
www.andantex.com

SEE OUR AD
P11

Applied Dynamics
www.applied-dynamics.com

Area Distributors Inc.
areadist.com

Arnold Magnetic Technologies
www.arnoldmagnetics.com

Arrow Gear Co.
www.arrowgear.com

Artec Machine Systems
www.artec-machine.com

Asahi Intecc USA, Inc.
www.asahi-inteccusa.com

ASI Technologies Inc.
www.asidrives.com

Assun Motor Pte Ltd
www.assunmotor.com

Atlanta Drive Systems Inc.
www.atlantadrives.com

Atlanta Gear Works
www.atlantagear.com

ATO Inc
www.ato.com

Avion Technologies Inc.
www.avion-tech.com

B&B Manufacturing, Inc.
www.bbman.com

B & R Machine and Gear Corp.
4809 U.S. HWY. 45
SHARON, TN 38255
Phone: (731) 456-2636 or (800) 238-0651
Fax: (731) 456-3073
inquiry@brgear.com
www.brgear.com

SEE OUR AD
P68

Baart Industrial Group
www.baartgroup.com

Baker Hughes Div. of GE
www.bhge.com/midstream/lng/gearboxes

Bauer Gear Motor
www.bauergears.com

BDI - Bearing Distributors Inc.
www.bdiexpress.com

Bearing Engineering Company
bearingengineering.com

Bearing Headquarters
www.bearingheadquarters.com

Bearings and Industrial Supply Company, Inc.
www.bearingsnow.com

Bearing Service Company
www.bearing-service.com

Bevel Gears India Pvt. Ltd.
bevelgearsindia.com

Bierens Machinefabrieken B.V.
www.bierens.com

Bison Gear and Engineering Corp.
www.bisongear.com

BK Power Systems - An Integrated Corrosion Co.
www.bkpowersystems.com

Blaz-Man Gear, Inc.
www.blazmangear.com

Bodine Electric Company
www.bodine-electric.com

Boneng Transmission USA LLC
www.boneng.com/English

Bonfiglioli Riduttori S.p.A.
www.bonfiglioli.com



Bonfiglioli USA, Inc.
3541 HARGRAVE DRIVE
HEBRON KY 41048
Phone: (859) 334-3333
Fax: (859) 334-8888
mbx-industrialsalesusa@bonfiglioli.com
www.Bonfiglioli.com

SEE OUR AD
P27,53

Bosch Rexroth
www.boschrexroth-us.com

Boston Gear
www.bostongear.com

Brad Foote Gear Works, Inc
www.bradfoote.com

Broadway Gear
www.broadwaygear.com

Brother Gearmotors
200 CROSSING BLVD.
BRIDGEWATER, NJ 08807
Phone: (866) 523-6283
Fax: (908) 575-3743
garmotors@brother.com
www.brother-usa.com/Garmotors

SEE OUR AD
IFC

Buehler Motor, Inc.
www.buehlermotor.com

C-B Gear & Machine, Inc.
www.cbgear.com

Cattini North America Corp.
www.cattinina.com

Central Gear & Machine
www.cgmatlanta.com

Cestari Industrial e Comercial S.A.
www.cestari.com.br

Challenge Power Transmission (Aust) Pty Ltd
www.challengept.com

Chenta Gear USA
www.chenta.com

Cincinnati Gearing Systems
5757 MARIEMONT AVE.
CINCINNATI, OH 45227
Phone: (513) 527-8600
Fax: (513) 527-8635
gearsales@cst-c.com
www.cincinnati-gearingsystems.com

SEE OUR AD
P16

Cleveland Gear Co.
www.clevelandgear.com

Cogmatic
www.cogmatic.com

Columbia Gear Corp.
www.columbiagear.com

Comtec Mfg., Inc.
www.comtecmfg.com

Cone Drive
www.conedrive.com

Cotta Transmission Co. LLC
cotta.com

Currie Enterprises
www.currieenterprises.com

Curtis Machine Co. Inc.
curtismachine.com

Dalton Bearing Service, Inc.
www.daltonbearing.com

Davall Gears Ltd.
www.davall.com

David Brown Santasalo
www.dbsantasalo.com

David Brown Santasalo Canada Service Inc.
www.dbsantasalo.com

Delroyd Worm Gear
www.delroyd.com

Desch Canada Ltd.
www.desch.de

DieQua Corp.
180 COVINGTON DRIVE
BLOOMINGDALE, IL 60108
Phone: (630) 980-1133
Fax: (630) 980-1232
info@diequa.com
www.diequa.com

SEE OUR AD
P28,69

Dongyang Anzu Motor Smartech Co. Ltd.
www.microgearmotor.com

Dorris Gear Drives
DorrisCo.com

Drive Lines Technologies Ltd
www.drivelines.co.uk

Duff Norton Australia
www.duffnorton.com.au

Dunkermotoren USA Inc.
www.dunkermotoren.com

Electronic Machine Parts
www.empregister.com

Elliott Manufacturing
www.elliottmfg.com

Emerson Industrial Automation - Drives & Motor
www.emerson.com/en-us/automation-solutions

Ensinger Precision Components
www.plastockonline.com

Essential Power Transmission Pvt. Ltd.
www.esenpro.com

Excel Gear, Inc.
www.excelgear.com

Exlar Actuation Solutions
www.exlar.com

Fairchild Industrial Products Co.
www.fairchildproducts.com

FMC Engineering
www.fmcengineering.com

Forgital Group
www.forgital.com

Framo Morat Inc.
www.framo-morat.com

GAM Enterprises
www.gamweb.com

Gayatri Gear Industries
www.gayatrigear.com

GearTec
www.geartec.com

Ghatge Patil Industries
www.gpi.co.in

Gibbs Gears Precision Engineers
www.gibbsgears.com

GKN Automotive
www.gknautomotive.com

Gleason Plastic Gears
www.gleasonplasticgears.com

Groschopp Inc.
www.groschopp.com

Hallmark Industries Inc.
www.hallmarkind.com

Hangzhou Ocean Industry Co., Ltd.
www.hzoic.com

Hangzhou Xingda Machinery Co. Ltd.
www.xdmade.com

Harmonic Drive LLC
www.harmonicdrive.net

Haumea Srl
www.haumea.com

Hoffmann Technics AG
www.hoffmann-tech.ch

Houston Pump and Gear
www.houstonpumpandgear.com

HPB Motion Control Co. Ltd.
www.hpb-industry.com

HVH Industrial Solutions
hvhindustrial.com

I-MAK Reduktor

SANAYI CAD. NO:1 / SEYHLI - PENDIK
ISTANBUL 34000
TURKEY
Phone: +90 2163780326
Fax: +902163780686
export@imakreduktor.com
www.imakreduktor.com

SEE OUR AD
P69

IBT Industrial Solutions
www.ibtinc.com

IMO USA Corp.
www.imo.us

IMS LLC
www.intermotionsupply.com

Industrial Automation Co.
www.industrialautomation.co

Innovative Rack & Gear
www.gearacks.com

Integrated Components Inc.
www.integratedcomponentsinc.com

Involute Powergear Pvt. Ltd.
www.involutetools.com

ISC Companies
isccompanies.com

jbj Techniques Limited
www.jbj.ca.uk

JIE Drives

493 MISSION STREET
CAROL STREAM, IL 60188
Phone: (630) 580-9986
info@jie-drives.com
jie-drives.com

SEE OUR AD
P67

Juncera Automations
junceraautomations.com

JVL Industri Elektronik A/S
www.jvl.dk

K+S Services
www.k-and-s.com

Kachelmann Getriebe GmbH
www.kachelmann.de

Kamar Industries
www.kamarindustries.com

KEB America, Inc.
kebblog.com

Kinematics Manufacturing, Inc.
www.kinematicsmfg.com

Kisco Gears
www.kiscogears.com

Kollmorgen
www.kollmorgen.com

Koro Industries, Inc.
www.koroind.com

Kraft Power Corporation
www.kraftpower.com

Lafert North America

5620 KENNEDY ROAD
MISSISSAUGA ON L4Z 2A9
CANADA
Phone: (905) 629-1939 or toll free (800) 661-6413
Fax: (905) 629-2852
sales@lafertna.com
www.lafertna.com

SEE OUR AD
P35

Leeson Electric
www.leeson.com

Lenze Americas
www.lenze.com

Li Gear
www.ligear.com

Logan Clutch Corp
www.logandutch.com

Machinists Inc.
machinistsinc.com

Malloy Electric
www.MalloyWind.com

Marshall Engineering Works
www.marshallgears.com

Maxon Precision Motors
www.maxonmotorusa.com

Midwest Gear & Tool, Inc.
www.powertransmission.com/copage/956_Midwest-Gear/

Midwest Motion Products
www.midwestmotion.com

MIJNO-USA
mijno.com

Miki Pulley

13200 6TH AVENUE NORTH
PLYMOUTH, MN 55441
Phone: (800) 533-1731
Fax: (763) 546-8260
sales@mikipulley-us.com
www.mikipulley-us.com

SEE OUR AD
P38

Minsk Gear Works
www.mgw.by

Mitsubishi Electric Automation, Inc.
us.mitsubishielectric.com/fa/en

MMR Precision Gears
www.mastermachinerepair.com

Molon Motor and Coil

300 NORTH RIDGE AVE.
ARLINGTON HEIGHTS, IL 60005
Phone: (847) 253-6000
Fax: (847) 259-0299
www.molon.com

SEE OUR AD
P41

Motion Industries
www.motionindustries.com

Moventas Ltd.
www.moventas.com

MPT Drives, Inc.
www.mptdrives.com

Muratech Engineering Company
www.muracopower.co.in

Nabtesco Motion Control, Inc.
www.nabtescomotioncontrol.com

Neugart USA Corp
www.neugart.com/en-us/

New Power Electric (USA) LLC
www.usa-newpower.com

NGC Transmission Europe GmbH
www.NGCtransmission.com

Niebuhr Gears
www.niebuhr.dk

Ningbo Zhongda Leader Intelligent Transmission Co.
www.zddriver.com

Ningbo Zhongyi Hydraulic Motor Co. Ltd.
www.zihyd.com

NORD DRIVESYSTEMS
www.nord.com

Nordex, Inc.

426 FEDERAL ROAD
BROOKFIELD, CT 06804
Phone: 203-775-4877
Fax: 203-775-6552
sales@nordex.com
www.nordex.com

SEE OUR AD
P69

Northwest Electric Motor Company
northwestmotor.com

Nuttall Gear
www.nuttallgear.com

Oerlikon Fairfield
www.oerlikon.com/fairfield

Ondrives US Corp.
www.ondrivesus.com

Onvio LLC
www.onviollc.com

Orbitless Drives, Inc
www.orbitless.com

Ormec
www.ormec.com

P. G. DRIVE
www.pgdrive.com

Parker Hannifin SSD Drives Div.
www.parker.com/ssdusa

Performance Gear Systems, Inc.
www.performance-gear.com

Philadelphia Gear (A Timken Brand)

901 EAST 8TH AVENUE, SUITE 100
KING OF PRUSSIA PA 19406
Phone: (800) 766-5120
Fax: (610) 337-5637
www.philagear.com

SEE OUR AD
P9

Phytron, Inc.
www.phytron.com

PIC Design
www.pic-design.com

Pinpoint Laser Systems
pinpointlaser.com

Plastock - Putnam Precision Molding, Inc.
www.plastockonline.com

Portescap
www.portescap.com

Power Electric
www.powerelectric.com

Power Engineering and Manufacturing
www.pemltd.com

Power Jack Motion
www.powerjackmotion.com

Precipart
www.precipart.com

Precision Microdrives Limited
www.precisionmicrodrives.com

Precision Pump and Gear Works
www.ppg-works.com

Pulsgetriebe GmbH & Co. KG
www.pulsgetriebe.com

QTC Metric Gears
www.qtcgears.com

Quality Reducer Service
www.qualityreducer.com

Rae DC Products Group
www.raemotors.com

Regal

200 STATE STREET
BELOIT WI 53511
Phone: 800-626-2120
Fax: (800) 262-3292
lan.Rubin@regalbeloit.com
www.regalbeloit.com

SEE OUR AD
P13

Renk Test Systems
www.renkstest.com

Renold
www.renold.com

Rex Engineering Corp.
www.rex-engineering.com

Rexnord
www.rexnord.com

RGW Sales Canada
www.rgwsalescanada.com

Riley Gear Corporation
www.rileygear.com

Ringball Corporation
www.ringball.com

Rj Link International, Inc.
www.rjlink.com

Rockwell Automation
www.rockwellautomation.com

Rolling Motion Industries
www.rmidrive.com

Sensata Technologies
www.sensata.com

Sesame Motor Corp.
www.sesamemotor.com.tw

Setco Precision Spindles, Slides & Service
www.setco.com

SEW-Eurodrive
1295 OLD SPARTANBURG HWY.
P.O. BOX 518
LYMAN, SC 29635
Phone: (864) 439-7537
Fax: (864) 439-7830
www.seweurodrive.com

SEE OUR AD
IBC

Shijiazhuang CAPT Power Transmission Co., Ltd
www.chssb.com

Shreecon Gear
shreecongear.com

Siemens Industry, Inc.
www.usa.siemens.com/industry/us/en

Sinotech
www.sinotech.com

SIPCO
12610 GALVESTON ROAD
WEBSTER TX 77598
Phone: 2814808711
www.sipco-mls.com

SEE OUR AD
P69

Siti Spa Riduttori
www.sitiriduttori.it

Six Star
www.sixstar.com.tw

Snow Nabstedt Power Transmissions Inc
www.snpt.biz

Sokhi Heli-Wom Gears Pvt. Ltd.
www.gearboxindia.com

Source Engineering Inc.
www.sei-automation.com

Southern Gear & Machine
www.southerngear.net

Spencer Pettus
www.spgear.com

Spiroid Gearing
1601 36TH AVENUE
ALEXANDRIA, MN 56308
Phone: (320) 762-7132
www.spiroidgearing.com

SEE OUR AD
P36

SPN Schwaben Praezision
www.spn-hopf.de

SPX Cooling Technologies, Inc.
www.spxcooling.com

Star Gears
www.stargears.in

ST Gear & Machine LLC
www.stgearandmachine.com

STM Riduttori Spa
www.stmspa.com

Stober Drives, Inc.
www.stober.com

Stock Drive Products/Sterling Instrument (SDP/SI)
250 DUFFY AVENUE
HICKSVILLE, NY 11801
Phone: (516) 328-3300
Fax: (516) 326-8827
sdp-sisupport@sdp-si.com
www.sdp-si.com

SEE OUR AD
P19

Stoffel Polygon Systems, Inc.
www.stoffelpolygon.com

Sumitomo Drive Technologies
www.sumitomodrive.com

Supreme Gear Co.
www.supremegear.com

Systrand Manufacturing Corporation
www.systrand.com

Tampa Armature Works- TAW
www.tawinc.com

Team Industries
www.team-ind.com

TelcoMotion
www.telcointercon.com

Thomson Industries Inc.
www.thomsonlinear.com

Tien Yi Gear Works Co., Ltd
www.tienyigear.com.tw

Toledo Gearmotor
www.toledogear.com

Tolomatic, Inc.
www.tolomatic.com

Torque Transmission
www.torquetrans.com

Transmission Machinery Co., Ltd
www.transcyko-transtec.com

Transply Inc.
www.transply.com

Triumph Gear Systems - Acr Industries
www.triumphgroup.com

Trojon Gear Inc.
www.trojon-gear.com

Turner Uni-Drive
www.turnerunidrive.com

TVT America, Inc.
www.tvtamerica.com

U.S. Tsubaki
301 E. MARQUARDT DR.
WHEELING, IL 60090
Phone: (847) 459-9500
Fax: (847) 459-9515
sales@ustsubaki.com
www.ustsubaki.com

SEE OUR AD
P31

United Gear Works
unitedgearworks.com

Var-Spe Variatori Oleodinamici
www.varspe.com

Varitron Engineering (Taiwan) Co., Ltd
www.c-var.com

Venture Mfg. Co.
www.venturemfgco.com

VL Motion Systems Inc.
www.vlmotion.com

Voith Turbo Inc
voith.com/usa/en/index.html

W.M. Berg
www.wmberg.com

Wajax
www.wajax.com

WEG
www.weg.net

Wittenstein
www.wittenstein-us.com

WMH Transmissions Ltd
www.wmh-trans.co.uk

WorldWide Electric Corporation
3540 WINTON PLACE
ROCHESTER NY 14623
Phone: 800-808-2131
Fax: 800-711-1616
customerservice@worldwideelectric.net
www.worldwideelectric.net

SEE OUR AD
P12

WPT Power Corporation
www.wptpower.com

Xtek, Inc.
www.xtek.com

Yantai Bonway Manufacturer Co. Ltd.
www.bonwaygroup.com

Yilmaz Reduktor Sanayi ve Tic A.S.
www.yr.com.tr

York Industries
www.york-ind.com

Zero-Max
13200 SIXTH AVENUE NORTH
MINNEAPOLIS, MN 55441
Phone: (763) 546-4300
Fax: (763) 546-8260
sales@zero-max.com
www.zero-max.com

SEE OUR AD
P89

Zhengzhou AOKMAN Machinery Co. Ltd.
www.aokman-gearbox.com

ZRIME
www.zrime.com.cn

ZZN Transmission Plant
www.zzn-transmissions.com

GEAR MANUFACTURING SERVICES

A&A Coatings
www.thermalspray.com

ABL Products Incorporated
www.ablproducts.com

Accent Bearings Co. Inc.
www.accentbearing.com

Accurate Gear and Machine, Inc.
accurategear.com

Ace World Companies
www.aceworldcompanies.com

Acme Gear Co.
www.acmegear.com

Affiliated Distributors
www.adhq.com

Agnee Transmissions (I) Pvt Ltd
www.agneetransmissions.com

Agro Engineers
www.agroengineers.com

Allied Gear Co.
www.thealliedgearco.com

Allied Specialty Precision Inc.
www.aspi-nc.com

American Gear & Engineering
www.americangear.net

American Gear, Inc.
www.americangearinc.com

American Swiss Products
www.americanswiss.com

Ametric / American Metric Corporation
www.ametric.com

AmTech International
www.amtechinternational.com

Ancon Gear & Instrument Corp.
www.ancongear.com

Andec Mfg. Ltd.
www.andec.ca

Artec Machine Systems
www.artec-machine.com

Ascent Precision Gear Corporation
www.ascentgear.com

ASI Technologies Inc.
www.asidrives.com

ATA Gears Ltd.
www.atagears.fi

Atlanta Gear Works
www.atlantagear.com

Avion Technologies Inc.
www.avion-tech.com

B&B Manufacturing, Inc.
www.bbman.com

B & R Machine and Gear Corp.
4809 U.S. HWY. 45
SHARON, TN 38255
Phone: (731) 456-2636 or (800) 238-0651
Fax: (731) 456-3073
inquiry@brgear.com
www.brgear.com

SEE OUR AD
P68

Baart Industrial Group
www.baartgroup.com

Baker Hughes Div. of GE
www.bhge.com/midstream/lng/gearboxes

Bearing Engineering Company
bearingengineering.com

Bearing Headquarters
www.bearingheadquarters.com

Bearing Service Company
www.bearing-service.com

Beaver Aerospace and Defense Inc.
www.beaver-online.com

Beyta Gear Service
www.beytagear.com

Bharat Gears Ltd.
www.bharatgears.com

Bierens Machinefabrieken B.V.
www.bierens.com

Blaz-Man Gear, Inc.
www.blazmangear.com

Brelie Gear Company, Inc
www.breliegear.com

Broadway Gear
www.broadwaygear.com

Buffalo Gear, Inc.
www.buffalogear.com

Butler Gear
www.butlertgear.com

C-B Gear & Machine, Inc.
www.cbgear.com

Carnes-Miller Gear Co., Inc.
www.cmgear.com

Cattini & Figlio s.r.l.
www.cattini.com

Cattini North America Corp.
www.cattinina.com

Central Gear & Machine
www.cgmatlanta.com

Chenta Gear USA
www.chenta.com

Cincinnati Gearing Systems

5757 MARIEMONT AVE.
CINCINNATI, OH 45227
Phone: (513) 527-8600
Fax: (513) 527-8635
gearsales@cst-c.com
www.cincinnati-gearing-systems.com

SEE OUR AD
P16

Circle Gear & Machine Co.

1501 S. 55TH COURT
CICERO, IL 60804
Phone: (708) 652-1000
Fax: (708) 652-1100
sales@circlegear.com
www.circlegear.com

SEE OUR AD
P14

Clarke Engineering Inc. (Clarke Gear Co.)
clarkegear.com

Cleveland Gear Co.
www.clevelandgear.com

Cloyes Gear & Products Inc.
www.cloyes.com

Cogmatic
www.cogmatic.com

Columbia Gear Corp.
www.columbiagear.com

Commercial Gear & Sprocket Co. Inc.
www.commercialgear.com

Comtec Mfg., Inc.
www.comtecmfg.com

Cone Drive
www.conedrive.com

Cross + Morse
www.crossmorse.com

Curtis Machine Co. Inc.
curtismachine.com

Custom Machine & Tool Co. Inc.
www.cmtco.com

Dalton Bearing Service, Inc.
www.daltonbearing.com

Davall Gears Ltd.
www.davall.com

David Brown Santasalo
www.dbsantasalo.com

David Brown Santasalo Canada Service Inc.
www.dbsantasalo.com

Delta Gear Corp.
www.delta-gear.com

Dorris Gear Drives
DorrisCo.com

Drive Lines Technologies Ltd
www.drivelines.co.uk

Electronic Machine Parts
www.empregister.com

Ellwood City Forge Group
www.ellwoodcityforge.com

Ensinger Precision Components
www.plastockonline.com

EquipNet
www.equipnet.com

Excel Gear, Inc.
www.excelgear.com

FMC Engineering
www.fmcengineering.com

Forest City Gear Co.
11715 MAIN STREET
ROSCOE, IL 61073
Phone: (815) 623-2168
Fax: (815) 623-6620
www.forestcitygear.com

SEE OUR AD
P3

Forgital Group
www.forgital.com

Framo Morat Inc.
www.framo-morat.com

Friel Metal Resurfacing
www.frielmetalsurfacing.com

Gayatri Gear Industries
www.gayatrige.com

Gear Design & Service Pty. Ltd.
www.geardesign.com.au

Gearench
www.gearench.com/products/gears-pinions.asp

Gear Master Inc.
www.gearmaster.us

Gear Motions, Inc.
www.gearmotions.com

GearTec
www.geartec.com

Gibbs Gears Precision Engineers
www.gibbsgears.com

GKN Automotive
www.gknautomotive.com

Gleason Plastic Gears
www.gleasonplasticgears.com

Global DriveTrain, Inc.
www.globaldrivetraininc.com

Hangzhou Ocean Industry Co., Ltd.
www.hzoic.com

Havlik Gear
www.havlikgear.com

Hayes Manufacturing Inc.
hayescouplings.com

Hoffmann Technics AG
www.hoffmann-tech.ch

Houston Pump and Gear
www.houstonpumpandgear.com

I-MAK Reduktor
SANAYI CAD. NO:1 / SEYHLI - PENDIK
ISTANBUL 34000
TURKEY
Phone: +90 2163780326
Fax: +902163780686
export@imakreduktor.com
www.imakreduktor.com

SEE OUR AD
P69

IBT Industrial Solutions
www.ibtinc.com

Innovative Rack & Gear
www.gearacks.com

Integrated Components Inc.
www.integratedcomponentsinc.com

ISC Companies
isccompanies.com

JIE Drives
493 MISSION STREET
CAROL STREAM, IL 60188
Phone: (630) 580-9986
info@jie-drives.com
jie-drives.com

SEE OUR AD
P67

Kachelmann Getriebe GmbH
www.kachelmann.de

Kamar Industries
www.kamarindustries.com

Kean Transmission Machinery Co.
www.keancn.com

Kisco Gears
www.kiscogears.com

Koro Industries, Inc.
www.koroinc.com

Li Gear
www.ligear.com

Machinists Inc.
machinistsinc.com

Magnum Manufacturing
magnum-mfg.com

Marshall Engineering Works
www.marshallgears.com

Martin Sprocket & Gear
www.martinsprocket.com

MIJNO-USA
mijno.com

Mini-Broach Machine Company
minibroach.com

Minsk Gear Works
www.mgw.by

MMR Precision Gears
www.mastermachinerepair.com

Motor & Gear Engineering Inc.
www.motorgearengineer.com

Moventas Ltd.
www.moventas.com

MPT Drives, Inc.
www.mptdrives.com

MT Tool & Manufacturing
www.mttoolinc.com

Muratech Engineering Company
www.muracopower.co.in

Nabtesco Motion Control, Inc.
www.nabtescomotioncontrol.com

Neugart USA Corp
www.neugart.com/en-us/

New Allenberry Works (Deepak Industries Ltd.)
www.allenberrygears.com

Nichiei Company, Ltd.
54 TOMAHAWK TRAIL
SPARTA, NEW JERSEY 07871
Phone: 973-729-2355
lizgershon@att.net
www.nichiei-ind.com/english/index.html

SEE OUR AD
P59

Niebuhr Gears
www.niebuhr.dk

Nordex, Inc.
426 FEDERAL ROAD
BROOKFIELD, CT 06804
Phone: 203-775-4877
Fax: 203-775-6552
sales@nordex.com
www.nordex.com

SEE OUR AD
P69

Northwest Electric Motor Company
northwestmotor.com

Nuttall Gear
www.nuttallgear.com

Oerlikon Fairfield
www.oerlikon.com/fairfield

Ondrives US Corp.
www.ondrivesus.com

Ontario Gear and Spline
www.ontariogearandspline.com

Orbitless Drives, Inc.
www.orbitless.com

P. G. DRIVE
www.pgdrive.com

Performance Gear Systems, Inc.
www.performance-gear.com

Perry Technology Corporation
www.perrygear.com

Philadelphia Gear (A Timken Brand)

901 EAST 8TH AVENUE, SUITE 100
KING OF PRUSSIA PA 19406
Phone: (800) 766-5120
Fax: (610) 337-5637
www.philagear.com

SEE OUR AD
P9

Phoenix Tool & Thread Grinding
phoenixthreadgrinding.com

PIC Design
www.pic-design.com

Power Electric
www.powerelectric.com

Power Engineering and Manufacturing
www.pemltd.com

Pragati Transmission Pvt Ltd
www.pragatigears.com

Precipart
www.precipart.com

Precision Pump and Gear Works
www.ppg-works.com

Precision Technologies Group (PTG) Ltd.
www.ptgltd.com

PST Group (Precision Screw Thread)
www.thepstgroup.com

Pulley Manufacturers International Inc.
www.pulleys.com

Pulsgetriebe GmbH & Co. KG
www.pulsgetriebe.com

QTC Metric Gears
www.qtcgears.com

Quality Reducer Service
www.qualityreducer.com

Rave Gears LLC
www.ravegears.com

Regal

200 STATE STREET
BELOIT WI 53511
Phone: 800-626-2120
Fax: (800) 262-3292
lan.Rubin@regalbeloit.com
www.regalbeloit.com

SEE OUR AD
P13

Reliance Gear Corporation
www.reliancegear.com

Renishaw Inc
www.renishaw.com

Renk Test Systems
www.renkstest.com

Renold
www.renold.com

Rexnord
www.rexnord.com

Riley Gear Corporation
www.rileygear.com

Riverside Spline and Gear
www.splineandgear.com

Rj Link International, Inc.
www.rjlink.com

Ronson Gears Pty. Ltd.
www.ronsongears.com.au

Rotek
www.rotek-inc.com

Rush Gears Inc.
www.rushgears.com

SBT Gearing Solutions
sbt-gears.co.uk

Schafer Industries
www.schafergear.com

Shivam Autotech Ltd.
www.shivamautotech.com

Shreecon Gear
shreecongear.com

Sichuan Mighty Machinery Co. Ltd.
www.sc-mighty.com

SIPCO

12610 GALVESTON ROAD
WEBSTER TX 77598
Phone: 2814808711
www.sipco-mls.com

SEE OUR AD
P69

Six Star
www.sixstar.com.tw

Sokhi Heli-Wom Gears Pvt. Ltd.
www.gearboxindia.com

Southern Gear & Machine
www.southerngear.net

Spencer Pettus
www.spgear.com

Spiroid Gearing
1601 36TH AVENUE
ALEXANDRIA, MN 56308
Phone: (320) 762-7132
www.spiroidgearing.com

SEE OUR AD
P36

SPN Schwaben Praezision
www.spn-hopf.de

Sprockets Australia Pty. Ltd.
sprocketsoz.com.au

ST Gear & Machine LLC
www.stgearandmachine.com

Stock Drive Products/Sterling Instrument (SDP/SI)

250 DUFFY AVENUE
HICKSVILLE, NY 11801
Phone: (516) 328-3300
Fax: (516) 326-8827
sdp-sisupport@sdp-si.com
www.sdp-si.com

SEE OUR AD
P19

Stoffel Polygon Systems, Inc.
www.stoffelpolygon.com

Suhner Manufacturing Inc.
www.suhner.com

Supreme Gear Co.
www.supremegear.com

Suzhou Asia Pacific Metal Co., Ltd.
www.szapmc.com

Team Industries
www.team-ind.com

Thermal Spray Coatings - A&A Coatings
www.thermalspray.com

Tien Yi Gear Works Co., Ltd
www.tienyigear.com.tw

Toledo Gearmotor
www.toledogear.com

Transmission Machinery Co., Ltd
www.transcyko-transtec.com

Trojon Gear Inc.
www.trojon-gear.com

Turner Uni-Drive
www.turnerunidrive.com

United Gear Works
unitedgearworks.com

USA Borescopes
www.USABorescopes.com

VCST LP
www.vcst.be

Venture Mfg. Co.
www.venturemfgco.com

Victrex Gear Solutions
www.victrex.com/en/gears/

Viking Forge, LLC
www.viking-forge.com

Vision Quality Components, Inc
www.visionqci.com

VW Vwbroaching Service Inc.
www.vwbroaching.com

Wajax
www.wajax.com

WEG
www.weg.net

WMH Transmissions Ltd
www.wmh-trans.co.uk

York Industries
www.york-ind.com

ZRIME
www.zrime.com.cn

ZZN Transmission Plant
www.zzn-transmissions.com

GEARS

ABB Motors and Mechanical Inc.
www.abb.com

ABL Products Incorporated
www.ablproducts.com

Accent Bearings Co. Inc.
www.accentbearing.com

Accurate Gear and Machine, Inc.
accurategear.com

Acme Gear Co.
www.acmegear.com

Aero Gear Inc.
aerogear.com

Affiliated Distributors
www.adhq.com

Agnee Transmissions (I) Pvt Ltd
www.agneetransmissions.com

Agro Engineers
www.agroengineers.com

Akgears, LLC
www.akgears.com

Akron Gear and Engineering
www.akrongear.com

Allied Gear Co.
www.thealliedgearco.com

Allied Specialty Precision Inc.
www.aspi-nc.com

American Gear & Engineering
www.americangear.net

American Gear, Inc.
www.americangearinc.com

American Swiss Products
www.americanswiss.com

Ametric / American Metric Corporation
www.ametric.com

AmTech International
www.amtechinternational.com

Ancon Gear & Instrument Corp.
www.ancongear.com

Andantex USA Inc.

1705 VALLEY ROAD
WANAMASSA, NJ 07712
Phone: (732) 493-2812
Fax: (732) 493-2949
info@andantex.com
www.andantex.com

SEE OUR AD
P11

Area Distributors Inc.
areadist.com

Arnold Magnetic Technologies
www.arnoldmagnetics.com

Arrow Gear Co.
www.arrowgear.com

Artec Machine Systems
www.artec-machine.com

Asahi Intecc USA, Inc.
www.asahi-inteccusa.com

Ascent Precision Gear Corporation
www.ascentgear.com

ASCO Sintering Co.
www.ascosintering.com

ASI Technologies Inc.
www.asidrives.com

AST Bearings
www.astbearings.com

ATA Gears Ltd.
www.atagears.fi

Atlanta Drive Systems Inc.
www.atlantadrives.com

Atlanta Gear Works
www.atlantagear.com

Avion Technologies Inc.
www.avion-tech.com

B&B Manufacturing, Inc.
www.bbman.com

B & R Machine and Gear Corp.

4809 U.S. HWY. 45
SHARON, TN 38255
Phone: (731) 456-2636 or (800) 238-0651
Fax: (731) 456-3073
inquiry@brgear.com
www.brgear.com

SEE OUR AD
P68

Baart Industrial Group
www.baartgroup.com

Baker Hughes Div. of GE
www.bhge.com/midstream/lng/gearboxes

Bartlett Bearing Company, Inc.
www.bartlettbearing.com

BDI - Bearing Distributors Inc.
www.bdiexpress.com

Bearing Engineering Company
bearingengineering.com

Bearing Headquarters
www.bearingheadquarters.com

Bearings and Industrial Supply Company, Inc.
www.bearingsnow.com

Bearings Limited
www.bearingslimited.com

Beaver Aerospace and Defense Inc.
www.beaver-online.com

Befared
www.befared.com/pl

Bevel Gears India Pvt. Ltd.
bevelgearsindia.com

Bharat Gears Ltd.
www.bharatgears.com

Bierens Machinefabrieken B.V.
www.bierens.com

Bison Gear and Engineering Corp.
www.bisongear.com

BK Power Systems - An Integrated Corrosion Co.
www.bkpowersystems.com

Blaz-Man Gear, Inc.
www.blazmangear.com

Bonfiglioli Riduttori S.p.A.
www.bonfiglioli.com

Bosch Rexroth
www.boschrexroth-us.com

Boston Gear
www.bostongear.com

Brad Foote Gear Works, Inc
www.bradfoote.com

Brelie Gear Company, Inc
www.breliegear.com

Brewer Machine & Gear Co.
www.brewertensioner.com

Broadway Gear
www.broadwaygear.com

Brother Gearmotors

200 CROSSING BLVD.
BRIDGEWATER, NJ 08807
Phone: (866) 523-6283
Fax: (908) 575-3743
garmotors@brother.com
www.brother-usa.com/Garmotors

SEE OUR AD
IFC

Buffalo Gear, Inc.
www.buffalogear.com

Butler Gear
www.butlergear.com

C&U Americas, LLC
www.cubearing.com

C-B Gear & Machine, Inc.
www.cbgear.com

Capstan Atlantic
www.capstanatlantic.com

Carnes-Miller Gear Co., Inc.
www.cmgear.com

Cattini & Figlio s.r.l.
www.cattini.com

Cattini North America Corp.
www.cattinina.com

CCTY Bearing
www.CCTYBearing.com

Central Gear & Machine
www.cgmatlanta.com

Chenta Gear USA
www.chenta.com

CIMA S.p.A.
www.cimaingranaggi.it

Cincinnati Gearing Systems

5757 MARIEMONT AVE.
CINCINNATI, OH 45227
Phone: (513) 527-8600
Fax: (513) 527-8635
gearsales@cst-c.com
www.cincinnati-gearingsystems.com

SEE OUR AD
P16

Circle Gear & Machine Co.

1501 S. 55TH COURT
CICERO, IL 60804
Phone: (708) 652-1000
Fax: (708) 652-1100
sales@circlegear.com
www.circlegear.com

SEE OUR AD
P14

Clarke Engineering Inc. (Clarke Gear Co.)
clarkegear.com

Cleveland Gear Co.
www.clevelandgear.com

Cloyes Gear & Products Inc.
www.cloyes.com

Cogmatic
www.cogmatic.com

Columbia Gear Corp.
www.columbiagear.com

Commercial Gear & Sprocket Co. Inc.
www.commercialgear.com

Comtec Mfg., Inc.
www.comtecmmfg.com

Cone Drive
www.conedrive.com

Cross + Morse
www.crossmorse.com

Curtis Machine Co. Inc.
curtismachine.com

Custom Machine & Tool Co. Inc.
www.cmtco.com

Dalton Bearing Service, Inc.
www.daltonbearing.com

Dana Brevini USA
www.brevini.us

Davall Gears Ltd.
www.davall.com

David Brown Santasalo
www.dbsantasalo.com

David Brown Santasalo Canada Service Inc.
www.dbsantasalo.com

Delroyd Worm Gear
www.delroyd.com

Delta Gear Corp.
www.delta-gear.com

Delta Research Corp.
www.deltaresearch.com

DePe Gear Company Ltd
www.depe.co.uk

Desch Canada Ltd.
www.desch.de

Dorris Gear Drives
DorrisCo.com

Drive Lines Technologies Ltd
www.drivelines.co.uk

Dunkermotoren USA Inc.
www.dunkermotoren.com

Electronic Machine Parts
www.empregister.com

Elliott Manufacturing
www.elliottmfg.com

Ellwood City Forge Group
www.ellwoodcityforge.com

Ensinger Precision Components
www.plastockonline.com

Essential Power Transmission Pvt. Ltd.
www.esenpro.com

Excel Gear, Inc.
www.excelgear.com

First Gear Engineering & Technology
www.first-gear.com

FMC Engineering
www.fmcengineering.com

Forest City Gear Co.

11715 MAIN STREET
ROSCOE, IL 61073
Phone: (815) 623-2168
Fax: (815) 623-6620
www.forestcitygear.com

SEE OUR AD
P3

Forgital Group
www.forgital.com

Framo Morat Inc.
www.framo-morat.com

Gayatri Gear Industries
www.gayatrigear.com

Gear Design & Service Pty. Ltd.
www.geardesign.com.au

Gearench
www.gearench.com/products/gears-pinions.asp

Gear Manufacturing Inc.
www.gearmfg.com

Gear Master Inc.
www.gearmaster.us

Gear Motions, Inc.
www.gearmotions.com

GearTec
www.geartec.com

Gibbs Gears Precision Engineers
www.gibbsgears.com

GKN Automotive
www.gknautomotive.com

Gleason Plastic Gears
www.gleasonplasticgears.com

Global DriveTrain, Inc.
www.globaldrivetraininc.com

GMN Bearing USA, Ltd.
www.gmnbt.com

GNA Gears
www.gnagears.com

Groschopp Inc.
www.groschopp.com

Hangzhou Ocean Industry Co., Ltd.
www.hzoic.com

Hangzhou Xingda Machinery Co. Ltd.
www.xdmade.com

Havlik Gear
www.havlikgear.com

Hayes Manufacturing Inc.
hayescouplings.com

Hoffmann Technics AG
www.hoffmann-tech.ch

Houston Pump and Gear
www.houstonpumpandgear.com

I-MAK Reduktor

SANAYI CAD. NO:1 / SEYHLI - PENDIK
ISTANBUL 34000
TURKEY
Phone: +90 2163780326
Fax: +902163780686
export@imakreduktor.com
www.imakreduktor.com

SEE OUR AD
P69

IBT Industrial Solutions
www.ibtinc.com

IG Watteew USA
www.igwpower.com

IMO USA Corp.
www.imo.us

Industrial Pulley & Machine Co, Inc.
www.industrialpulley.com

Industrial Spares Manufacturing Co.
www.industrialsparesfromindia.com

Innovative Rack & Gear
www.gearacks.com

Intech Corporation
www.intechpower.com

Involute Powergear Pvt. Ltd.
www.involutetools.com

Involute Simulation Software Inc.
www.hygears.com

ISC Companies
isccompanies.com

JIE Drives

493 MISSION STREET
CAROL STREAM, IL 60188
Phone: (630) 580-9986
info@jie-drives.com
jie-drives.com

SEE OUR AD
P67

JVL Industri Elektronik A/S
www.jvl.dk

Kamar Industries
www.kamarindustries.com

Kaydon Corporation Bearings (A SKF Brand)
www.kaydonbearings.com

Kean Transmission Machinery Co.
www.keancn.com

KHK USA Inc
www.khkgears.us

Kiesler Machine Inc.
www.kieslermachine.com

Kinematics Manufacturing, Inc.
www.kinematicsmfg.com

Kisco Gears
www.kiscogears.com

Koro Industries, Inc.
www.koroind.com

Li Gear
www.ligear.com

LYC North America Inc
lycbearings.com

Machinists Inc.
machinistsinc.com

Magnum Manufacturing
magnum-mfg.com

Maguire Technologies
www.maguiretech.com

Malloy Electric
www.MalloyWind.com

Marshall Engineering Works
www.marshallgears.com

Martin Sprocket & Gear
www.martinsprocket.com

Maxon Precision Motors
www.maxonmotorusa.com

McInnes Rolled Rings

1533 EAST 12TH STREET
ERIE, PA 16511
Phone: (814) 459-4495
Fax: (814) 459-8443
sales@mcrings.com
www.mcinnserolledrings.com

SEE OUR AD
P18

Midwest Gear & Tool, Inc.
www.powertransmission.com/copage/956_Midwest-Gear/

Midwest Motion Products
www.midwestmotion.com

MIJNO-USA
mijno.com

Mini-Broach Machine Company
minibroach.com

Mini Gears (Stockport) Ltd.
www.minigears.co.uk

Minsk Gear Works
www.mgw.by

MMR Precision Gears
www.mastermachinerepair.com

Motion Industries
www.motionindustries.com

Moventas Ltd.
www.moventas.com

MPT Drives, Inc.
www.mptdrives.com

MT Tool & Manufacturing
www.mttoolinc.com

Muratech Engineering Company
www.muracopower.co.in

Netshape Technologies, Inc.
www.netshapetech.com

Neugart USA Corp
www.neugart.com/en-us/

New Allenberry Works (Deepak Industries Ltd.)
www.allenberrygears.com

PLASTIC GEARS OPTIMIZE PRICE/PERFORMANCE

Expert Japanese Injection
Molder Focused on
Precision Gears

Discover what makes
Nichiei better.

Liz Gershon
lizgershon@att.net
973.729.2355

Nichiei
www.nichiei-ind.com/english/

Nichiei Company, Ltd.

54 TOMAHAWK TRAIL
SPARTA, NEW JERSEY 07871
Phone: 973-729-2355
lizgershon@att.net
www.nichiei-ind.com/english/index.html

SEE OUR AD
P59

Niebuhr Gears
www.niebuhr.dk

Nordex, Inc.

426 FEDERAL ROAD
BROOKFIELD, CT 06804
Phone: 203-775-4877
Fax: 203-775-6552
sales@nordex.com
www.nordex.com

SEE OUR AD
P69

Northwest Electric Motor Company
northwestmotor.com

Nu-Teck Couplings Pvt. Ltd
www.nuteckcouplings.com

Nuttall Gear
www.nuttallgear.com

Oerlikon Fairfield
www.oerlikon.com/fairfield

Ondrives US Corp.
www.ondrivesus.com

Ontario Gear and Spline
www.ontariogearandspline.com

Orbitless Drives, Inc
www.orbitless.com

P. G. DRIVE
www.pgdrive.com

P.T. International Corp. (PTI)
www.ptintl.com

Performance Gear Systems, Inc.
www.performance-gear.com

Perry Technology Corporation
www.perrygear.com

PIC Design
www.pic-design.com

Plastock - Putnam Precision Molding, Inc.
www.plastockonline.com

Portescap
www.portescap.com

Power Electric
www.powerelectric.com

Pragati Transmission Pvt Ltd
www.pragatigears.com

Precipart
www.precipart.com

Precision Pump and Gear Works
www.ppg-works.com

Precision Technologies Group (PTG) Ltd.
www.ptgltd.com

PST Group (Precision Screw Thread)
www.thepstgroup.com

Pulley Manufacturers International Inc.
www.pulleys.com

Pulsgetriebe GmbH & Co. KG
www.pulsgetriebe.com

QTC Metric Gears
www.qtcgears.com

Quality Bearings & Components

250 DUFFY AVENUE
HICKSVILLE, NY 11801
Phone: (516) 616-0436
Fax: (516) 616-0443
qbcsupport@qbcbearings.com
www.qbcbearings.com

SEE OUR AD
P25,43

Rave Gears LLC
www.ravegears.com

RBI Bearing Inc.

101 S. GARY AVE., STE. B
ROSELLE IL 60172
Phone: 800-708-2128
Fax: (630) 295-5490
info@rbibearing.com
www.rbibearing.com

SEE OUR AD
P5**Regal**

200 STATE STREET
BELOIT WI 53511
Phone: 800-626-2120
Fax: (800) 262-3292
lan.Rubin@regalbeloit.com
www.regalbeloit.com

SEE OUR AD
P13

Reliance Gear Corporation
www.reliancegear.com

Renold
www.renold.com

Riley Gear Corporation
www.rileygear.com

Ringball Corporation
www.ringball.com

Ritbearing Corp.
www.ritbearing.com

Riverside Spline and Gear
www.splineandgear.com

Rj Link International, Inc.
www.rjlink.com

Ronson Gears Pty. Ltd.
www.ronsongears.com.au

Rotek
www.rottek-inc.com

Rush Gears Inc.
www.rushgears.com

SBT Gearing Solutions
sbt-gears.co.uk

Schaeffler Group USA Inc.
308 SPRINGHILL FARM ROAD
FORT MILL, SC 29715
Phone: (803) 548-8500
Fax: (803) 548-8599
info.us@schaeffler.com
www.schaeffler.us

SEE OUR AD
BOC

Schafer Industries
www.schafergear.com

Shanghai Shine Transmission Machinery Co. Ltd.
www.syptworld.com

Shijiazhuang CAPT Power Transmission Co., Ltd
www.chssb.com

Shivam Autotech Ltd.
www.shivamautotech.com

Shreecon Gear
shreecongear.com

Sichuan Mighty Machinery Co. Ltd.
www.sc-mighty.com

Sinotech
www.sinotech.com

SIPCO
12610 GALVESTON ROAD
WEBSTER TX 77598
Phone: 2814808711
www.sipco-mls.com

SEE OUR AD
P69

Siti Spa Riduttori
www.sitiriduttori.it

Six Star
www.sixstar.com.tw

SKF USA Inc.
www.skf.com

Snow Nabstedt Power Transmissions Inc
www.snpt.biz

Sokhi Heli-Wom Gears Pvt. Ltd.
www.gearboxindia.com

Source Engineering Inc.
www.sei-automation.com

Southern Gear & Machine
www.southerngear.net

Special Ingranaggi
www.specialingranaggi.com/en/

Spencer Pettus
www.spgear.com

Spiroid Gearing
1601 36TH AVENUE
ALEXANDRIA, MN 56308
Phone: (320) 762-7132
www.spiroidgearing.com

SEE OUR AD
P36

SPN Schwaben Praezision
www.spn-hopf.de

Sprockets Australia Pty. Ltd.
sprocketoz.com.au

The Steel Plate & Component Factory
www.steelplates.in

ST Gear & Machine LLC
www.stgearandmachine.com

STM Riduttori Spa
www.stmspa.com

Stock Drive Products/Sterling Instrument (SDP/SI)
250 DUFFY AVENUE
HICKSVILLE, NY 11801
Phone: (516) 328-3300
Fax: (516) 326-8827
sdp-sisupport@sdp-si.com
www.sdp-si.com

SEE OUR AD
P19

Suhner Manufacturing Inc.
www.suhner.com

Sumitomo Drive Technologies
www.sumitomodrive.com

Supreme Gear Co.
www.supremegear.com

Suzhou Asia Pacific Metal Co., Ltd.
www.szapmc.com

Systrand Manufacturing Corporation
www.systrand.com

Team Industries
www.team-ind.com

Thyssenkrupp Rothe Erde USA Inc.
www.thyssenkrupp-rotheerde.com

Tien Yi Gear Works Co., Ltd
www.tienyigear.com.tw

Toledo Gearmotor
www.toledogear.com

Torque Transmission
www.torque-trans.com

Transmission Machinery Co., Ltd
www.transcyko-transstec.com

Transply Inc.
www.transply.com

Triumph Gear Systems - Acr Industries
www.triumphgroup.com

Trojon Gear Inc.
www.trojon-gear.com

Tsubaki of Canada Limited
www.tsubaki.ca

Turner Uni-Drive
www.turnerunidrive.com

United Gear Works
unitedgearworks.com

VCST LP
www.vcst.be

Venture Products International
www.ventureproducts.com

Victrex Gear Solutions
www.victrex.com/en/gears/

Vision Quality Components, Inc
www.visionqci.com

Voith Turbo Inc
voith.com/usa/en/index.html

VW Broaching Service Inc.
www.vwbroaching.com

W.M. Berg
www.wmberg.com

Wajax
www.wajax.com

WD Bearing America
www.wd-bearings.com

WJB Group
www.wjbgroup.com

WMH Transmissions Ltd
www.wmh-trans.co.uk

Xtek, Inc.
www.xtek.com

Yieh Chen Machinery (Six Star Group)
www.yiehchen.com

York Industries
www.york-ind.com

Zero-Max
13200 SIXTH AVENUE NORTH
MINNEAPOLIS, MN 55441
Phone: (763) 546-4300
Fax: (763) 546-8260
sales@zero-max.com
www.zero-max.com

SEE OUR AD
P89

ZRIME
www.zrime.com.cn

ZZN Transmission Plant
www.zzn-transmissions.com

INDUSTRIAL HARDWARE AND MACHINE PARTS

Affiliated Distributors
www.adhq.com

AGA Parts
www.aga-parts.com

Bartlett Bearing Company, Inc.
www.bartlettbearing.com

Bearing Engineering Company
bearingengineering.com

Bearing Headquarters
www.bearingheadquarters.com

BK Power Systems - An Integrated Corrosion Co.
www.bkpowersystems.com

C-Flex Bearing Co., Inc.
www.c-flex.com

Comtec Mfg., Inc.
www.comtecmfg.com

Conveyor Accessories Inc.
www.conveyoraccessories.com

Daemar Inc.
www.daemar.com

Dendoff Springs
www.Dendoff.com

Fixtureworks
www.fixtureworks.net

G.L. Huyett
www.huyett.com

Gear Master Inc.
www.gearmaster.us

Hi-Grade Inc.
www.higradeinc.com

Houston Pump and Gear
www.houstonpumpandgear.com

HVH Industrial Solutions
hvhindustrial.com

ISC Companies
isccompanies.com

J.W. Winco Inc.
www.jwwinco.com

John Evans' Sons
www.springcompany.com

Kiesler Machine Inc.
www.kieslermachine.com

Koro Industries, Inc.
www.koroind.com

Machinists Inc.
machinistsinc.com

Martin Sprocket & Gear
www.martinsprocket.com

Melfast
www.melfast.com

Metric & Multistandard Components Corp
www.metricmcc.com

Motion Industries
www.motionindustries.com

Mubea
www.mubea-discsprings.com

National Bearings Company
www.nationalbearings.com

Netshape Technologies, Inc.
www.netshapetech.com

Nichiei Company, Ltd.
54 TOMAHAWK TRAIL
SPARTA, NEW JERSEY 07871
Phone: 973-729-2355
lizgershon@att.net
www.nichiei-ind.com/english/index.html

SEE OUR AD
P59

Nordex, Inc.
426 FEDERAL ROAD
BROOKFIELD, CT 06804
Phone: 203-775-4877
Fax: 203-775-6552
sales@nordex.com
www.nordex.com

SEE OUR AD
P69

Ondrives US Corp.
www.ondrivesus.com

Premier Udyog
www.premierudyog.org

Rexnord
www.rexnord.com

SIPCO
12610 GALVESTON ROAD
WEBSTER TX 77598
Phone: 2814808711
www.sipco-mls.com

SEE OUR AD
P69

Smalley Steel Ring Company
www.smalley.com

The Steel Plate & Component Factory
www.steelplates.in

Stock Drive Products/Sterling Instrument (SDP/SI)
250 DUFFY AVENUE
HICKSVILLE, NY 11801
Phone: (516) 328-3300
Fax: (516) 326-8827
sdp-sisupport@sdp-si.com
www.sdp-si.com

SEE OUR AD
P19

W.M. Berg
www.wmberg.com

Wajax
www.wajax.com

York Industries
www.york-ind.com

LINEAR MOTION DEVICES

ABB Motors and Mechanical Inc.
www.baldor.com

Accent Bearings Co. Inc.
www.accentbearing.com

Acorn Industrial Services Ltd.
www.acorn-ind.co.uk

Advanced Control Systems Corporation
www.acsmotion.com

Aerotech Inc.
www.aerotech.com

Affiliated Distributors
www.adhq.com

AGI Automation Components
www.agi-automation.com

AISCO Industrial Couplings
www.aiscoinc.com

Allied International
www.alliedinter.com

Amacoil, Inc.
www.amacoil.com

Ametric / American Metric Corporation
www.ametric.com

Andantex USA Inc.
1705 VALLEY ROAD
WANAMASSA, NJ 07712
Phone: (732) 493-2812
Fax: (732) 493-2949
info@andantex.com
www.andantex.com

SEE OUR AD
P11

Area Distributors Inc.
areadist.com

Arnold Magnetic Technologies
www.arnoldmagnetics.com

AST Bearings
www.astbearings.com

Atlanta Drive Systems Inc.
www.atlantadrives.com

BDI - Bearing Distributors Inc.
www.bdiexpress.com

Bearing Engineering Company
bearingengineering.com

Bearing Headquarters
www.bearingheadquarters.com

Bearings and Industrial Supply Company, Inc.
www.bearingsnow.com

Beaver Aerospace and Defense Inc.
www.beaver-online.com

Bishop-Wisecarver Corp.
www.bwc.com

BK Power Systems - An Integrated Corrosion Co.
www.bkpowersystems.com

Bosch Rexroth
www.boschrexroth-us.com

Clarke Engineering Inc. (Clarke Gear Co.)
clarkegear.com

CUI Inc
www.cui.com

Dalton Bearing Service, Inc.
www.daltonbearing.com

Davall Gears Ltd.
www.davall.com

David Brown Santasalo
www.dbsantasalo.com

Del-Tron Precision Inc.
www.deltron.com

DieQua Corp.
180 COVINGTON DRIVE
BLOOMINGDALE, IL 60108
Phone: (630) 980-1133
Fax: (630) 980-1232
info@diequa.com
www.diequa.com

SEE OUR AD
P28,69

Discovery Technology International, Inc.
www.dtimotors.com

Dongyang Anuze Motor Smartech Co. Ltd.
www.microgearmotor.com

Dover Motion
www.dovermotion.com

Drive Lines Technologies Ltd
www.drivelines.co.uk

Duff-Norton
www.duffnorton.com

Duff Norton Australia
www.duffnorton.com.au

Dunkermotoren USA Inc.
www.dunkermotoren.com

Durabond Slide
www.durabondslide.com

Dynamic Structures and Materials, Llc
www.dynamic-structures.com

Dynatect Manufacturing Inc. (fka A & A Mfg.)
www.dynatect.com

Dynex/Rivett Inc.
www.dynexhydraulics.com

Elliott Manufacturing
www.elliottmfg.com

Emerson Industrial Automation - Drives & Motor
www.emerson.com/en-us/automation-solutions

Exlar Actuation Solutions
www.exlar.com

Festo Corporation
www.festo.com/usa

FMC Engineering
www.fmcengineering.com

Framo Morat Inc.
www.framo-morat.com

H2W Technologies
www.h2wtech.com

Hallmark Industries Inc.
www.hallmarkind.com

Houston Pump and Gear
www.houstonpumpandgear.com

HPB Motion Control Co. Ltd.
www.hpb-industry.com

HVH Industrial Solutions
hvhindustrial.com

IAI America, Inc.
www.intelligentactuators.com

IBT Industrial Solutions
www.ibtinc.com

IDA Motion Inc.
www.idamotion.com

IKO International Inc.
www.ikont.com

IMS LLC
www.intermotionsupply.com

Intellidrives, Inc
www.intellidrives.com

ISC Companies
isccompanies.com

K+S Services
www.k-and-s.com

Kollmorgen
www.kollmorgen.com

Leeson Electric
www.leeson.com

Machinists Inc.
machinistsinc.com

Mavilor Motors, S.a.
www.mavilor.es

Melfast
www.melfast.com

Midwest Motion Products
www.midwestmotion.com

Mitsubishi Electric Automation, Inc.
us.mitsubishielectric.com/fa/en

Modern Linear Inc.
www.modernlinear.com

Molon Motor and Coil
300 NORTH RIDGE AVE.
ARLINGTON HEIGHTS, IL 60005
Phone: (847) 253-6000
Fax: (847) 259-0299
www.molon.com

SEE OUR AD
P38

MOONS' Industries
www.moonsindustries.com

Motion Industries
www.motionindustries.com

Nichiei Company, Ltd.
54 TOMAHAWK TRAIL
SPARTA, NEW JERSEY 07871
Phone: 973-729-2355
lizgershon@att.net
www.nichiei-ind.com/english/index.html

SEE OUR AD
P59

Nordex, Inc.
426 FEDERAL ROAD
BROOKFIELD, CT 06804
Phone: 203-775-4877
Fax: 203-775-6552
sales@nordex.com
www.nordex.com

SEE OUR AD
P69

Northwest Electric Motor Company
northwestmotor.com

Novotec Argentina SRL
www.novotecargentina.com

NSK Corporation
www.nskamericas.com/en/industries/industrial/power-transmission.html

Ormec
www.ormec.com

Orttech
www.orttech.com

Parker Hannifin SSD Drives Div.
www.parker.com/ssdusa

Performance Gear Systems, Inc.
www.performance-gear.com

Phytron, Inc.
www.phytron.com

PI (Physik Instrumente) L.P. Piezo Actuator Nano
www.pi-usa.us

PIC Design
www.pic-design.com

Portescap
www.portescap.com

Power Electric
www.powerelectric.com

Precipart
www.precipart.com

Precision Technologies Group (PTG) Ltd.
www.ptgltd.com

PST Group (Precision Screw Thread)
www.thepstgroup.com

Rex Engineering Corp.
www.rex-engineering.com

RGW Sales Canada
www.rgwsalescanada.com

Ringball Corporation
www.ringball.com

Rockwell Automation
www.rockwellautomation.com

Roton Products
www.rotom.com

Schaeffler Group USA Inc.

308 SPRINGHILL FARM ROAD
FORT MILL, SC 29715
Phone: (803) 548-8500
Fax: (803) 548-8599
info.us@schaeffler.com
www.schaeffler.us

SEE OUR AD
BOC

Sensata Technologies
www.sensata.com

Serapid Inc.
www.serapid.us

Servometer
www.servometer.com

Sesame Motor Corp.
www.sesamemotor.com.tw

SEW-Eurodrive

1295 OLD SPARTANBURG HWY.
P.O. BOX 518
LYMAN, SC 29635
Phone: (864) 439-7537
Fax: (864) 439-7830
www.seweurodrive.com

SEE OUR AD
IBC

Siemens Industry, Inc.
www.usa.siemens.com/industry/us/en

SKF USA Inc.
www.skf.com

SPN Schwaben Praezision
www.spn-hopf.de

The Steel Plate & Component Factory
www.steelplates.in

Steinmeyer Inc.
www.steinmeyer.com

Stock Drive Products/Sterling Instrument (SDP/SI)

250 DUFFY AVENUE
HICKSVILLE, NY 11801
Phone: (516) 328-3300
Fax: (516) 326-8827
sdp-sisupport@sdp-si.com
www.sdp-si.com

SEE OUR AD
P19

Stoffel Polygon Systems, Inc.
www.stoffelpolygon.com

Tampa Armature Works- TAW
www.tawinc.com

TDK InvenSense
www.invensense.com

Technico
www.technico.com

Tecnotion BV
www.tecnotion.com

TelcoMotion
www.telcointercon.com

Therm-X
www.therm-x.com

Thomson Industries Inc.
www.thomsonlinear.com

Tolomatic, Inc.
www.tolomatic.com

TVT America, Inc.
www.tvtamerica.com

Venture Mfg. Co.
www.venturemfgco.com

VL Motion Systems Inc.
www.vlmotion.com

W.M. Berg
www.wmberg.com

Wajax
www.wajax.com

Warner Linear
www.warnerlinear.com

WEG
www.weg.net

Whittet-Higgins Company
whittet-higgins.com

Wittenstein
www.wittenstein-us.com

WMH Transmissions Ltd
www.wmh-trans.co.uk

Yaskawa America, Inc.
www.yaskawa.com

LUBRICATION

Acorn Industrial Services Ltd.
www.acorn-ind.co.uk

Affiliated Distributors
www.adhq.com

AIMS Industrial Supplies
www.aimsindustrial.com.au

American Chemical Technologies, Inc.
www.americanchemtech.com

Atlanta Drive Systems Inc.
www.atlantadrives.com

Avalon International Corp.
www.avalongateway.com

BDI - Bearing Distributors Inc.
www.bdiexpress.com

Bearing Boys Ltd
www.bearingboys.co.uk

Bearing Engineering Company
bearingengineering.com

Bearing Headquarters
www.bearingheadquarters.com

Bearings and Industrial Supply Company, Inc.
www.bearingsnow.com

Bearing Service Company
www.bearing-service.com

Bibby Turboflex
www.bibbyturboflex.com

BK Power Systems - An Integrated Corrosion Co.
www.bkpowersystems.com

Checkfluid
www.checkfluid.com

Chesterton
chestertonlubricants.chesterton.com/en-us

Cortec Corporation
www.cortecvci.com

Dalton Bearing Service, Inc.
www.daltonbearing.com

Daubert Cromwell LLC
www.daubertcromwell.com

Elkem Silicones
www.silicones.elkem.com

Extreme Industrial Lubricants
www.extremelubricants.com

Filter Pumper / Hydraulic Problems, Inc.
www.filterpumper.com

G.L. Huyett
www.huyett.com

GearTec
www.geartec.com

Gleason Plastic Gears
www.gleasonplasticgears.com

Houghton International Inc.
www.houghtonintl.com

HVH Industrial Solutions
hvhindustrial.com

IBT Industrial Solutions
www.ibtinc.com

Integrated Components Inc.
www.integratedcomponentsinc.com

ISC Companies
isccompanies.com

Isel Inc.
iselinc.com

Klüber Lubrication North America L.P.
www.kluber.com

Kyodo Yushi USA Inc.
www.kyodoyushiusa.com

Lovejoy, Inc. (A Timken Brand)
www.lovejoy-inc.com

The Lubricant Store
thelubricantstore.com

Lubriplate Lubricants Co.
www.lubriplate.com

Malloy Electric
www.MalloyWind.com

Microsurface Corporation
www.ws2coating.com

Motion Industries
www.motionindustries.com

MROSupply
www.mrosupply.com

oelheld U.S., Inc.
www.oelheld.com

Quality Bearings & Components

250 DUFFY AVENUE
HICKSVILLE, NY 11801
Phone: (516) 616-0436
Fax: (516) 616-0443
qbcsupport@qbcbearings.com
www.qbcbearings.com

SEE OUR AD
P25,43

Regal

200 STATE STREET
BELOIT WI 53511
Phone: 800-626-2120
Fax: (800) 262-3292
lan.Rubin@regalbeloit.com
www.regalbeloit.com

SEE OUR AD
P13

Rexnord
www.rexnord.com

Schaeffler Group USA Inc.

308 SPRINGHILL FARM ROAD
FORT MILL, SC 29715
Phone: (803) 548-8500
Fax: (803) 548-8599
info.us@schaeffler.com
www.schaeffler.us

SEE OUR AD
BOC

Simatec Inc.
www.simatec.com

SKF USA Inc.
www.skf.com

SPX Cooling Technologies, Inc.
www.spxcooling.com

Stock Drive Products/Sterling Instrument (SDP/SI)

250 DUFFY AVENUE
HICKSVILLE, NY 11801
Phone: (516) 328-3300
Fax: (516) 326-8827
sdp-sisupport@sdp-si.com
www.sdp-si.com

SEE OUR AD
P19

Sumitomo Drive Technologies
www.sumitomodrive.com

Tien Yi Gear Works Co., Ltd
www.tienyigear.com.tw

Transmission Machinery Co., Ltd
www.transcyko-transtec.com

Transply Inc.
www.transply.com

United Gear Works
unitedgearworks.com

Wajax
www.wajax.com

WD Bearing America
www.wd-bearings.com

Whitmore
whitmores.com

MOTORS

ABB Motors and Mechanical Inc.
www.baldor.com

ABM DRIVES INC.
abm-drives.us

Accent Bearings Co. Inc.
www.accentbearing.com

Acorn Industrial Services Ltd.
www.acorn-ind.co.uk

Advanced Control Systems Corporation
www.acsmotion.com

Aerotech Inc.
www.aerotech.com

Affiliated Distributors
www.adhq.com

Allied Motion
www.alliedmotion.com

Ametric / American Metric Corporation
www.ametric.com

Applied Dynamics
www.applied-dynamics.com

Arc Systems, Inc
www.arcsystemsinc.com

Area Distributors Inc.
areadist.com

Arnold Magnetic Technologies
www.arnoldmagnetics.com

ASI Technologies Inc.
www.asidrives.com

Assun Motor Pte Ltd
www.assunmotor.com

ATO Inc
www.ato.com

Automation Direct
www.automationdirect.com

BDI - Bearing Distributors Inc.
www.bdiexpress.com

Bearing Engineering Company
bearingengineering.com

Bearing Headquarters
www.bearingheadquarters.com

Bearings and Industrial Supply Company, Inc.
www.bearingsnow.com

Bison Gear and Engineering Corp.
www.bisongear.com

BK Power Systems - An Integrated Corrosion Co.
www.bkpowersystems.com

Bodine Electric Company
www.bodine-electric.com

Bonfiglioli Riduttori S.p.A.
www.bonfiglioli.com

Bonfiglioli USA, Inc.

3541 HARGRAVE DRIVE
HEBRON KY 41048

Phone: (859) 334-3333

Fax: (859) 334-8888

mbx-industrialsalesusa@bonfiglioli.com

www.Bonfiglioli.com

Bosch Rexroth
www.boschrexroth-us.com

Boston Gear
www.bostongear.com

Brother Gearmotors

200 CROSSING BLVD.
BRIDGEWATER, NJ 08807

Phone: (866) 523-6283

Fax: (908) 575-3743

gearmotors@brother.com

www.brother-usa.com/Gearmotors

BSF, Inc.
www.bsfinc.net

Buehler Motor, Inc.
www.buehlermotor.com

CNC Center
www.cnccenter.com

Cone Drive
www.conedrive.com

Custom Motors Inc.
www.custommotorsmn.com

Cutes Corporation
www.cutes.com.tw

Dalton Bearing Service, Inc.
www.daltonbearing.com

Davall Gears Ltd.
www.davall.com

David Brown Santasalo
www.dbsantasalo.com

DieQua Corp.

180 COVINGTON DRIVE
BLOOMINGDALE, IL 60108

Phone: (630) 980-1133

Fax: (630) 980-1232

info@diequa.com

www.diequa.com

Discovery Technology International, Inc.
www.dtimotors.com

Dongyang Anuze Motor Smartech Co. Ltd.
www.microgearmotor.com

Dover Motion
www.dovermotion.com

Drive Lines Technologies Ltd
www.drivelines.co.uk

Duff Norton Australia
www.duffnorton.com.au

Dunkermotoren USA Inc.
www.dunkermotoren.com

Dynex/Rivett Inc.
www.dynexhydraulics.com

Eagle PLC
www.eagleplc.com

Electronic Machine Parts
www.empregister.com

Electro Static Technology
www.est-aegis.com

Elektrim Motors
www.elektrimmotors.com

Emerson Industrial Automation - Drives & Motor
www.emerson.com/en-us/automation-solutions

Engifield Engineering
engifield.com

EquipNet
www.equipnet.com

Exlar Actuation Solutions
www.exlar.com

Festo Corporation
www.festo.comusa

Framo Morat Inc.
www.framo-morat.com

GearTec
www.geartec.com

GoHz Power Supply Inc
www.gohz.com

Groschopp Inc.
www.groschopp.com

H2W Technologies
www.h2wtech.com

Hallmark Industries Inc.
www.hallmarkind.com

Hansen Corporation
www.hansen-motor.com

Hoffmann Technics AG
www.hoffmann-tech.ch

HPB Motion Control Co. Ltd.
www.hpb-industry.com

HVH Industrial Solutions
hvhindustrial.com

I-MAK Reduktor

SANAYI CAD. NO:1 / SEYHLI - PENDIK
ISTANBUL 34000

TURKEY

Phone: +90 2163780326

Fax: +902163780686

export@imakreduktor.com

www.imakreduktor.com

IBT Industrial Solutions
www.ibtinc.com

IMS LLC
www.intermotionsupply.com

Industrial Automation Co.
www.industrialautomation.co

Integrated Components Inc.
www.integratedcomponentsinc.com

Intellidrives, Inc
www.intellidrives.com

ISC Companies
isccompanies.com

JIE Drives

493 MISSION STREET
CAROL STREAM, IL 60188

Phone: (630) 580-9986

info@jie-drives.com

jie-drives.com

JVL Industri Elektronik A/S
www.jvl.dk

K+S Services
www.k-and-s.com

KEB America, Inc.
keblog.com

Kollmorgen
www.kollmorgen.com

Kraft Power Corporation
www.kraftpower.com

Lafert North America

5620 KENNEDY ROAD
MISSISSAUGA ON L4Z 2A9
CANADA

Phone: (905) 629-1939 or toll free (800) 661-6413

Fax: (905) 629-2852

sales@lafertna.com

www.lafertna.com

Leeson Electric
www.leeson.com

Lenze Americas
www.lenze.com

Malloy Electric
www.MalloyWind.com

Mark Elektriks
www.markelektriks.com

Mavilor Motors, S.a.
www.mavilores.com

Maxon Precision Motors
www.maxonmotorusa.com

Midwest Motion Products
www.midwestmotion.com

Mitsubishi Electric Automation, Inc.
us.mitsubishielectric.com/fa/en

Modicon PLC
www.modiconplc.com

Molon Motor and Coil

300 NORTH RIDGE AVE.
ARLINGTON HEIGHTS, IL 60005

Phone: (847) 253-6000

Fax: (847) 259-0299

www.molon.com

MOONS' Industries
www.moonsindustries.com

Motion Industries
www.motionindustries.com

MPT Drives, Inc.
www.mptdrives.com

MRO Electric and Supply
www.mroelectric.com

SEE OUR AD
P28,69

SEE OUR AD
P27,53

SEE OUR AD
IFC

SEE OUR AD
P69

SEE OUR AD
P67

SEE OUR AD
P35

SEE OUR AD
P38

MT Tool & Manufacturing
www.mttoolinc.com

Navyug Electric Motors & Pumps Ltd
www.navyugelectricmotors.com

New Power Electric (USA) LLC
www.usa-newpower.com

Ningbo Zhongyi Hydraulic Motor Co. Ltd.
www.zhyd.com

Northwest Electric Motor Company
northwestmotor.com

Novotec Argentina SRL
www.novotecargentina.com

NSK Corporation
www.nskamericas.com/en/industries/industrial/power-transmission.html

Oerlikon Fairfield
www.oerlikon.com/fairfield

Onvio LLC
www.onviollc.com

Orbitless Drives. Inc
www.orbitless.com

Ormec
www.ormec.com

Parker Hannifin SSD Drives Div.
www.parker.com/ssdusa

Performance Gear Systems, Inc.
www.performance-gear.com

Phytron, Inc.
www.phytron.com

PI (Physik Instrumente) L.P. Piezo Actuator Nano
www.pi-usa.us

Portescap
www.portescap.com

Power Electric
www.powerelectric.com

Precipart
www.precipart.com

Precision Microdrives Limited
www.precisionmicrodrives.com

Precision Pump and Gear Works
www.ppg-works.com

Rae DC Products Group
www.raemotors.com

Regal

200 STATE STREET
BELOIT WI 53511
Phone: 800-626-2120
Fax: (800) 262-3292
lan.Rubin@regalbeloit.com
www.regalbeloit.com

SEE OUR AD
P13

Rex Engineering Corp.
www.rex-engineering.com

Riley Gear Corporation
www.rileygear.com

Rockwell Automation
www.rockwellautomation.com

Rocky Mountain Technologies
www.rockymountaintechnologies.com

Schaeffler Group USA Inc.

308 SPRINGHILL FARM ROAD
FORT MILL, SC 29715
Phone: (803) 548-8500
Fax: (803) 548-8599
info.us@schaeffler.com
www.schaeffler.us

SEE OUR AD
BOC

Schneider Electric Motion USA
motion.schneider-electric.com

Sensata Technologies
www.sensata.com

Sesame Motor Corp.
www.sesamemotor.com.tw

SEW-Eurodrive

1295 OLD SPARTANBURG HWY.
P.O. BOX 518
LYMAN, SC 29635
Phone: (864) 439-7537
Fax: (864) 439-7830
www.seweurodrive.com

SEE OUR AD
IBC

Shanghai Shine Transmission Machinery Co. Ltd.
www.syptworld.com

Shengzhou Tianyi Electric Appliance Co., Ltd
www.zjszsty.com

Siemens Industry, Inc.
www.usa.siemens.com/industry/us/en

Sinotech
www.sinotech.com

SIPCO

12610 GALVESTON ROAD
WEBSTER TX 77598
Phone: 2814808711
www.sipco-mls.com

SEE OUR AD
P69

Siti Spa Riduttori
www.sitiriduttori.it

SKF USA Inc.
www.skf.com

Source Engineering Inc.
www.sei-automation.com

SPX Cooling Technologies, Inc.
www.spxcooling.com

Star Gears
www.stargears.in

STM Riduttori SpA
www.stmspa.com

Stock Drive Products/Sterling Instrument (SDP/SI)

250 DUFFY AVENUE
HICKSVILLE, NY 11801
Phone: (516) 328-3300
Fax: (516) 326-8827
sdp-sisupport@sdp-si.com
www.sdp-si.com

SEE OUR AD
P19

Sumitomo Drive Technologies
www.sumitomodrive.com

Tampa Armature Works- TAW
www.tawinc.com

Techtop Industries, Inc.
www.techttopind.com

Tecnotion BV
www.tecnotion.com

Teco Westinghouse
www.tecowestinghouse.com

TelcoMotion
www.telcointercon.com

Thomson Industries Inc.
www.thomsonlinear.com

Tien Yi Gear Works Co., Ltd
www.tienyigear.com.tw

Tolomatic, Inc.
www.tolomatic.com

Transmission Machinery Co., Ltd
www.transcyko-transtec.com

Transply Inc.
www.transply.com

TSS Rotterdam B.V.
www.tssr.nl

TVT America, Inc.
www.tvtamerica.com

Varitron Engineering (Taiwan) Co., Ltd
www.c-var.com

Venture Mfg. Co.
www.venturemfgco.com

VL Motion Systems Inc.
www.vlmotion.com

W.M. Berg
www.wmberg.com

Wajax
www.wajax.com

WEG
www.weg.net

Wittenstein
www.wittenstein-us.com

WorldWide Electric Corporation

3540 WINTON PLACE
ROCHESTER NY 14623
Phone: 800-808-2131
Fax: 800-711-1616
customerservice@worldwideelectric.net
www.worldwideelectric.net

SEE OUR AD
P12

Yaskawa America, Inc.
www.yaskawa.com

Yilmaz Reduktor Sanayi ve Tic A.S.
www.yr.com.tr

Zhengzhou AOKMAN Machinery Co. Ltd.
www.aokman-gearbox.com

RESOURCES

Affiliated Distributors
www.adhq.com

AGMA

1001 N. FAIRFAX STREET, SUITE 500
ALEXANDRIA, VA 22314-1587
Phone: (703) 684-0211
Fax: (703) 684-0242
webmaster@agma.org
www.agma.org

SEE OUR AD
P32-33

AGMA Media
www.powertransmission.com

Bartlett Bearing Company, Inc.
www.bartlettbearing.com

Beyta Gear Service
www.beytagear.com

BK Power Systems - An Integrated Corrosion Co.
www.bkpowersystems.com

Bosch Rexroth
www.boschrexroth-us.com

Comtec Mfg., Inc.
www.comtecmfg.com

David Brown Santasalo Canada Service Inc.
www.dbsantasalo.com

Deutsche Messe AG
www.messe.de

Dorris Gear Drives
DorrisCo.com

Industrial Careers Pathway (ICP)
www.ptda.org

Lafert North America

5620 KENNEDY ROAD
MISSISSAUGA ON L4Z 2A9
CANADA
Phone: (905) 629-1939 or toll free (800) 661-6413
Fax: (905) 629-2852
sales@lafertna.com
www.lafertna.com

SEE OUR AD
P35

Machine Guard & Cover Co.
machineguard.com

MCMA - Motion Control & Motor Association
www.motioncontrolonline.org

NSK Corporation
www.nskamericas.com/en/industries/industrial/power-transmission.html

Ondrives US Corp.
www.ondrivesus.com

Pioneer Motor Bearing Co.
www.pioneer1.com

PTDA
www.ptda.org

Regal

200 STATE STREET
BELOIT WI 53511
Phone: 800-626-2120
Fax: (800) 262-3292
lan.Rubin@regalbeloit.com
www.regalbeloit.com

SEE OUR AD
P13

Rocky Mountain Technologies
www.rockymountaintechnologies.com

Transmission Machinery Co., Ltd
www.transcyko-transtec.com

SEALS

Accent Bearings Co. Inc.
www.accentbearing.com

Acorn Industrial Services Ltd.
www.acorn-ind.co.uk

Affiliated Distributors
www.adhq.com

AIMS Industrial Supplies
www.aimsindustrial.com.au

Ametric / American Metric Corporation
www.ametric.com

Applied Dynamics
www.applied-dynamics.com

Area Distributors Inc.
areadist.com

Baart Industrial Group
www.baartgroup.com

Bartlett Bearing Company, Inc.
www.bartlettbearing.com

BDI - Bearing Distributors Inc.
www.bdiexpress.com

Bearing Engineering Company
bearingengineering.com

Bearing Headquarters
www.bearingheadquarters.com

Bearings and Industrial Supply Company, Inc.
www.bearingsnow.com

Bearing Service Company
www.bearing-service.com

BK Power Systems - An Integrated Corrosion Co.
www.bkpowersystems.com

Centritec Seals, LLC
www.centritecseals.com

Daemar Inc.
www.daemar.com

Dalton Bearing Service, Inc.
www.daltonbearing.com

Darbar Belting
www.darbarbelting.co.in

David Brown Santasalo Canada Service Inc.
www.dbsantasalo.com

EquipNet
www.equipnet.com

Functional Oil Seal Industrial Co., Ltd. - FOS
www.fos.com.tw

G.L. Huyett
www.huyett.com

Gallagher Fluid Seals, Inc.
www.gallagherseals.com

GearTec
www.geartec.com

GMN Bearing USA, Ltd.
www.gmnbt.com

Houston Pump and Gear
www.houstonpumpandgear.com

HVH Industrial Solutions
hvhindustrial.com

IBT Industrial Solutions
www.ibtinc.com

ISC Companies
isccompanies.com

J.W. Winco Inc.
www.jwwinco.com

jbj Techniques Limited
www.jbj.co.uk

Koro Industries, Inc.
www.koroind.com

Kyodo Yushi USA Inc.
www.kyodoyushiusa.com

Machinists Inc.
machinistsinc.com

Malloy Electric
www.MalloyWind.com

Metric & Multistandard Components Corp
www.metricmcc.com

Motion Industries
www.motionindustries.com

Moventas Ltd.
www.moventas.com

MROSupply
www.mrosupply.com

Nichiei Company, Ltd.
54 TOMAHAWK TRAIL
SPARTA, NEW JERSEY 07871
Phone: 973-729-2355
lizgershon@att.net
www.nichiei-ind.com/english/index.html

SEE OUR AD
P59

Northwest Electric Motor Company
northwestmotor.com

Pioneer Motor Bearing Co.
www.pioneer1.com

RGW Sales Canada
www.rgwsalescanada.com

Rubena a.s.
www.rubena.cz

SKF USA Inc.
www.skf.com

Smalley Steel Ring Company
www.smalley.com

SPX Cooling Technologies, Inc.
www.spxcooling.com

SSP Manufacturing, Inc
www.sspseals.com

Stock Drive Products/Sterling Instrument (SDP/SI)
250 DUFFY AVENUE
HICKSVILLE, NY 11801
Phone: (516) 328-3300
Fax: (516) 326-8827
sdp-sisupport@sdp-si.com
www.sdp-si.com

SEE OUR AD
P19

Transmission Machinery Co., Ltd
www.transcyko-transtec.com

Wajax
www.wajax.com

WJB Group
www.wjbgroup.com

Zerelli Technologies Inc
www.zerelli.com

SENSORS

Acorn Industrial Services Ltd.
www.acorn-ind.co.uk

Affiliated Distributors
www.adhq.com

Akron Gear and Engineering
www.akrongear.com

Allied Motion
www.alliedmotion.com

Andec Mfg. Ltd.
www.andec.ca

Applied Dynamics
www.applied-dynamics.com

Area Distributors Inc.
areadist.com

Arnold Magnetic Technologies
www.arnoldmagnetics.com

Assun Motor Pte Ltd
www.assunmotor.com

ATO Inc
www.ato.com

Automation Direct
www.automationdirect.com

Axu s.r.l.
www.axu.it

BDI - Bearing Distributors Inc.
www.bdiexpress.com

Bearing Engineering Company
bearingengineering.com

Bearing Headquarters
www.bearingheadquarters.com

BEI Sensors
www.beisensors.com

Binsfeld Engineering Inc.
www.binsfeld.com

Bison Gear and Engineering Corp.
www.bisongear.com

BK Power Systems - An Integrated Corrosion Co.
www.bkpowersystems.com

Bosch Rexroth
www.boschrexroth-us.com

Checkfluid
www.checkfluid.com

Comtel Corporation
www.comtel.com

CUI Inc
www.cui.com

Dalton Bearing Service, Inc.
www.daltonbearing.com

Datum Electronics Ltd
datum-electronics.co.uk

Drive Lines Technologies Ltd
www.drivelines.co.uk

Duff Norton Australia
www.duffnorton.com.au

Dunkermotoren USA Inc.
www.dunkermotoren.com

Electronic Machine Parts
www.empregister.com

EquipNet
www.equipnet.com

Fagor Automation
www.fagor-automation.com

Festo Corporation
www.festo.com/usa

The Fredericks Company
www.frederickscompany.com

FSI Technologies Inc.
www.fsinet.com

GP:50 Corporation
www.GP50.com

HBM
www.hbm.com

Heidenhain Corporation
www.heidenhain.com

Hitec Sensor Developments
www.hitecsensors.com

HPB Motion Control Co. Ltd.
www.hpb-industry.com

IBT Industrial Solutions
www.ibtinc.com

Intellidives, Inc
www.intellidives.com

ISC Companies
isccompanies.com

JIE Drives
493 MISSION STREET
CAROL STREAM, IL 60188
Phone: (630) 580-9986
info@jie-drives.com
jie-drives.com

SEE OUR AD
P67

JVL Industri Elektronik A/S
www.jvl.dk

K+S Services
www.k-and-s.com

Kavlico Corporation (A Sensata Technologies Brand)
www.kavlico.com

KEB America, Inc.
keblog.com

Magtrol, Inc.
www.magtrol.com

Mantracourt Electronics
www.mantracourt.com

Marshall Wolf Automation Inc.
www.wolfautomation.com

MATSolutions
www.matsolutions.com/Power-Meters-Sensors

Maxcess
www.maxcessintl.com

Maxon Precision Motors
www.maxonmotorusa.com

Mayr Corporation
www.mayr.com

Micronor Inc.
www.micronor.com

Midwest Motion Products
www.midwestmotion.com

Minh Anh Technology Solution Company Limited
www.masco.vn

Motion Industries
www.motionindustries.com

MTS Sensors
www.mtssensors.com

Novotec Argentina SRL
www.novotecargentina.com

PI (Physik Instrumente) L.P. Piezo Actuator Nano
www.pi-usa.us

Portescap
www.portescap.com

Potomac Electric
www.potomacelectric.com

Precipart
www.precipart.com

Quality Bearings & Components

250 DUFFY AVENUE
HICKSVILLE, NY 11801
Phone: (516) 616-0436
Fax: (516) 616-0443
qbcsupport@qbcbearings.com
www.qbcbearings.com

SEE OUR AD
P25,43

RDF Corporation
www.rdfcorp.com

Regal

200 STATE STREET
BELOIT WI 53511
Phone: 800-626-2120
Fax: (800) 262-3292
lan.Rubin@regalbeloit.com
www.regalbeloit.com

SEE OUR AD
P13

Renishaw Inc
www.renishaw.com

Rockwell Automation
www.rockwellautomation.com

Schenck USA
www.schenck-usa.com

Sensata Technologies
www.sensata.com

Sensor Products Inc.
www.sensorprod.com

Sensor Technology Ltd
www.sensors.co.uk

Sinotech
www.sinotech.com

SKF USA Inc.
www.skf.com

Source Engineering Inc.
www.sei-automation.com

Stellar Technology - Lord Corp.
www.stellartech.com

TDK InvenSense
www.invensense.com

Tef Cap Industries Inc.
www.tefcap.com

Tek-Trol LLC
www.tek-trol.com

Therm-X
www.therm-x.com

Transmission Machinery Co., Ltd
www.transcyko-transtec.com

Transply Inc.
www.transply.com

Variohm EuroSensor
www.variohm.com

Voith Turbo Inc
voith.com/usa/en/index.html

Wajax
www.wajax.com

Xtek, Inc.
www.xtek.com

SOFTWARE

1Factory
www.1factory.com

Affiliated Distributors
www.adhq.com

Bosch Rexroth
www.boschrexroth-us.com

Comtec Mfg., Inc.
www.comtecmsg.com

Engifield Engineering
engifield.com

Excel Gear, Inc.
www.excelgear.com

Hangzhou Shengda Bearing Co
www.china-sda.com/product/draglink/

Involute Simulation Software Inc.
www.hygears.com

KISSsoft AG (A Gleason Company)
www.kisssoft.ag

Lenze Americas
www.lenze.com

Mark Elektriks
www.markelektriks.com

MESYS AG
www.mesys.ag

MIJNO-USA
mijno.com

Shijiazhuang CAPT Power Transmission Co., Ltd
www.chssb.com

SMT - Smart Manufacturing Technology

CHARTWELL HOUSE
67-69 HOUNDS GATE
NOTTINGHAM NG1 6BB
UK

Phone: +44 (0)115 941 9839
Fax: +44 (0)115 958 1583
info@smartmt.com
www.smartmt.com

SEE OUR AD
P15

Therm-X
www.therm-x.com

Wajax
www.wajax.com

ZRIME
www.zrime.com.cn

Power Transmission Engineering online!

IT'S LIKE YOUR OWN **PROFESSIONAL SUPERPOWER.**

Stronger, faster and smarter than your average website, www.powertransmission.com offers everything you need to supercharge your engineering-oriented organization.

- Complete archive of articles on engineered components
- Directory of suppliers of gears, bearings, motors and other mechanical power transmission components
- Product and Industry News updated daily
- Exclusive online content in our e-mail newsletters
- The Bearings Blog
- Calendar of upcoming events
- Comprehensive search feature helps you find what you're looking for — *faster than a speeding bullet!*

www.powertransmission.com



JIE
JDRIVE



IP69K

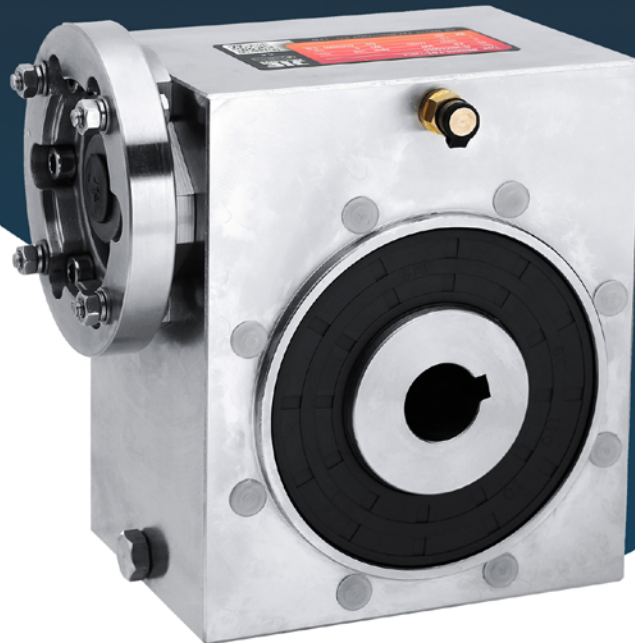

JRESND Stainless Steel Worm Gear Unit

- Ratio 7.5 - 100
- Size 40 / 50 / 63
- Viton & NBR Seal
- Laser Nameplate
- Material Stainless Steel 304
- NEMA Inputs 48 / 56 / 140 TC
- Food Grade Lubrication Option
- Hollow / Single / Double Output Shaft & Torque Arm

2 Day Delivery

- Assembled in USA

www.jie-drives.com Info@jie-drives.com +1 630 580 9986



We Can Handle It!

The only totally U.S. owned manufacturer of Link-V-Belting

DuroDrive

LINK V-BELT

BDH BELTS

Ph 717-871-0994
www.bdhbelts.com

Fax 717-871-0995
sales@bdhbelts.com

Engineering sMart is your resource for the latest in great ideas from our advertisers. Check this section every issue for sMart Engineering ideas and technology.

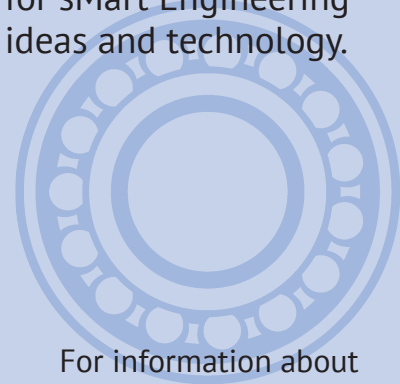

For information about advertising, contact Dave Friedman

at Dave Friedman

at

(847) 437-6604

or

dave@powertransmission.com



B&R

MACHINE AND GEAR CORP

BRGEAR.COM

High Performance Bevel Gearboxes

The Tandler Spiral Bevel gearbox is both precise and ideal for demanding applications where robustness and high torque density are required.



- 9 sizes
- 15 ratios
- Low backlash
- Customizable

DIEQUA
Corporation

diequa.com/pte 800-430-1439

Aluminum Worm Speed Reducers

Our aluminum worm speed reducers provide improved performance, high reliability and easy maintenance.



- 7 sizes, 28-110 mm CD
- 12 ratios from 5:1 to 100:1
- Flexible coupling input
- Aluminum housings
- NEMA, IEC, or Servo Motor Adapters

DIEQUA
Corporation

diequa.com/pte 800-276-1294

GEARMOTORS DESIGN, BUILT & ENGINEERED FOR RELIABILITY & DURABILITY BUILT IN THE USA!

Right Angle

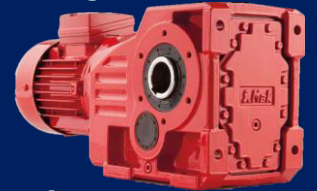

Helical Worm



Helical Inline



Shaft Mount



Worm Gearmotor



SIPCO i.Mak[®]
Gearboxes and Drives

281.480.8711

sales@sipco-imak.com

Precision Mechanical Components & Assemblies

Standard Industrial Components | Made To Print Parts



Gears, Pulleys, Shafts, Bearings, Couplings, Fasteners, Custom Gear Boxes
Value Added Features and Services

Engineering, Refurbishing & Design
Custom Made To Print Parts
Modified Standard Parts
Assemblies & Sub-Assemblies
Custom Mounts For Shafts
Build Sub-Assemblies And Complete Assemblies
Prototype Work

- ▶ Press bearings into pulleys
- ▶ Assemble bearings to shafts
- ▶ Set backlash on gears
- ▶ Assemble drive boxes
- ▶ Straightening
- ▶ Welding
- ▶ Kitting
- ▶ Plating / Custom Coating
- ▶ Heat treat

ADD

- Grooves • Flats • Keyways • Pins
- Threads • Staking • Pressing
- Testing

Nordex[®]
INCORPORATED

Nordex.com Sales@nordex.com Eng@nordex.com
Phone: (800) 243-0986 or Call: (203) 775-4877

Efficiency and Heat Balance Calculation of Worm Gears

Constantin Paschold, Martin Sedlmair,
Thomas Lohner and Karsten Stahl

Abbreviations

a [mm]; Center distance
 A [mm²]; Surface
 b [mm] | [J/(K · m² · √s²)]; Tooth width | Thermal effusivity
 c [J/K · kg]; Specific thermal capacity
 C_m [-]; Factor
 d_m [mm]; Mean diameter
 Fr [-]; Froude number
 g [m/s²]; Gravity
 h^* [-]; Relative lubrication gap height
 h_{ID} [mm]; Immersion depth
 $h_{min,m}$ [μm]; Minimal mean lubrication gap thickness
 I [A]; Current
 l [m]; Characteristic length
 L [W/K]; Thermal conductance
 n [min⁻¹]; Rotational speed
 P_a [W]; Output power
 P_A [W]; Input power
 P_V [W]; Total power losses
 P_{VD} [W]; Sealing losses
 P_{VLO} [W]; No-load bearing losses
 P_{VLP} [W]; Load-dependent bearing losses
 P_{VX} [W]; Other losses
 P_{VZO} [W]; No-load gear losses
 P_{VZP} [W]; Load-dependent gear losses
 Pr [-]; Prandtl number
 \dot{Q} [W]; Rate of heat flow
 R_{ohm} [Ω]; Resistance
 R_{th} [K/W]; Thermal resistance
 Re [-]; Reynolds number
 Rq [-]; Quadratic mean roughness
 T [Nm] | [°C]; Torque | Temperature
 u [-]; Gear ratio
 U [V]; Voltage
 v_{gm} [m/s]; Mean sliding velocity
 v_t [m/s]; Tangential velocity
 V [m³]; Volume
 Y_G [-]; Geometry reference factor
 Y_R [-]; Roughness reference factor
 Y_S [-]; Size reference factor
 Y_W [-]; Material reference factor
 z [-]; Number of teeth
 α [W/(m² · K)]; Heat transfer coefficient
 γ_m [°]; Pitch angle
 η [%] | [kg/m · s]; Efficiency | Dynamic viscosity
 η_z [%]; Gearing efficiency (worm shaft driving)
 η'_z [%]; Gearing efficiency (worm wheel driving)
 λ [-]; Relative lubricant film thickness
 μ_{0T} [-]; Base coefficient of friction
 μ_{Fl} [-]; Mean coefficient of fluid friction
 μ_{Gr} [-]; Mean coefficient of boundary friction

μ_{mz} [-]; Mean coefficient of friction
 ν [m²/s]; Kinematic viscosity
 ρ_{oil} [kg/m³]; Oil density
 σ_{lim} [N/mm²]; Mean flank pressure
 τ [s]; Time for a given tooth to leave the oil sump and start to mesh
 τ_{Fl} [N/mm²]; Shear stress
 τ_{lim} [N/mm²]; Limiting shear stress
 ω [rad⁻¹]; Angular velocity
 ψ [-]; Solid load portion

Introduction

If torque conversion with high gear ratio, compact installation space and 90-degree axis-crossing angle is needed, often worm gears are used. Due to their high power density and sliding speeds within the tooth contact, frictional heat and thermal stresses are higher compared to helical, bevel and hypoid gears, and thus the thermal load capacity of worm gears is lower (Ref. 24). Therefore, the prediction of the heat balance and component temperatures of gearboxes containing one or more worm gear stages is very important, especially during the design phase.

The simulation program *WTplus* (Ref. 16) has been developed to investigate the efficiency and heat balance of gearbox systems. The efficiency is based on the power loss calculation of gears, bearings, seals and other rotating elements. The subsequent calculation of the heat balance of the gearbox is based on the so-called “Thermal Network Method” (TNM) (Refs. 11, 15), which is a mathematical method for determining the heat transfer between single components, as well as the heat dissipation to the environment. A suitable abstraction of the gearbox system by nodal points forms the basis for an efficient and accurate calculation of local component temperatures. The current version of *WTplus* can analyze gearbox systems containing cylindrical and bevel gears.

In this study, an automatic simulation method for analyzing the efficiency and heat balance of various designs of worm gears is developed and integrated in *WTplus*. First, suitable methods and calculations regarding the efficiency and heat balance calculation of worm gears are shown. Its integration into the simulation program *WTplus* is described afterwards. Finally, simulated efficiency and heat balance results of various worm gearboxes are compared to measurements from research and industry.

This paper was first published on 27.01.2020 in Forschung im Ingenieurwesen (<https://doi.org/10.1007/s10010-019-00390-1>) as Open Access and licensed under a Creative Commons Attribution 4.0 International License (<http://creativecommons.org/licenses/by/4.0/>). It is republished here without changes.

State of the Art

Niemann (Ref. 23) and Weber (Ref. 40) mathematically modeled the tooth contact of worm gears. Wilkesmann (Ref. 41) performed elastohydrodynamic lubrication (EHL) calculations for different worm tooth geometries. Predki (Ref. 29) carried out parameter studies and developed relative key figures, which form the basis of DIN 3996:2019-09 (Ref. 9). Bouché (Ref. 3) formulated a physics-based model for the calculation of the coefficient of friction under mixed friction for worm gears. Magyar (Ref. 20) investigated the dynamics of worm gears and derived a tribological calculation model for the calculation of the coefficient of friction, which is the basis for a new standardizable approach for the calculation of worm gear efficiency (Ref. 25).

Monz (Ref. 22) and Mautner et al. (Ref. 21) investigated the load capacity and efficiency of worm gears lubricated by consistent grease. They used a specific TNM for heat balance calculations, which correspond closely to the measurements. Further approaches to using TNMs for heat balance and temperature calculations with regard to gearboxes can be found in (Ref. 26) for worm gears, (Ref. 14) for hypoid gears, (Refs. 4, 11, 19) for spur gears, (Refs. 6, 42) for planetary gears and (Ref. 38) for helical gears.

Although there are several approaches for the efficiency and heat balance calculation of worm gears, none of them uses an automatic approach to building the TNM. They either abstract their investigated gearbox as an isothermal system for which no temperature distribution can be calculated, or they build the TNM statically and specifically for an experimentally considered worm gearbox.

This is where the method shown in this paper excels; it describes a method for an automatic efficiency and heat balance calculation for various designs of worm gears.

Efficiency Calculation

The calculation of the efficiency of a system requires the knowledge of either the power input P_A and power loss P_V , or the power input P_A and power output P_a :

$$\eta = \frac{P_A - P_V}{P_A} = \frac{P_a}{P_a + P_V} = \frac{P_a}{P_A} \quad (1)$$

With regard to gearboxes, the overall power loss P_V can be described as the sum of partial power losses of the gearbox components as shown in Eq. (2). They are usually caused significantly by the gears (Z) and bearings (L), and by contacting seals (D). Depending on the gearbox, other losses (X) from auxiliary units, for example, may also occur. Gear losses and bearing losses can be subdivided into no-load (0) and load-dependent (P) losses (Ref. 13).

$$P_V = \underbrace{P_{VZ0} + P_{VZP}}_{\text{Gear Losses}} + \underbrace{P_{VL0} + P_{VLP}}_{\text{Bearing Losses}} + \underbrace{P_{VD}}_{\text{Sealing Losses}} + \underbrace{P_{VX}}_{\text{Other Losses}} \quad (2)$$

Figure 1 shows a Sankey diagram outlining the correlation of power input, power output and power losses, which are ultimately converted to heat.

Gear losses. Gear losses generally cause a significant proportion of the overall power loss. Friction within the contact

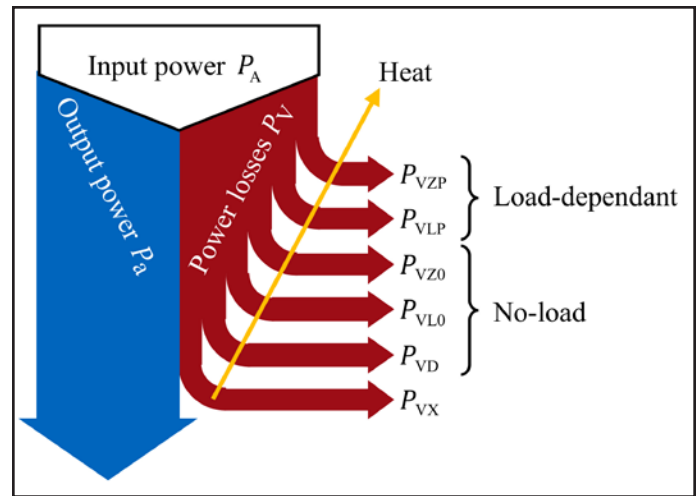

Figure 1 General gearbox power flow in form of a Sankey diagram based on Eq. (2).

of two tooth flanks relates to the applied load of the tooth system and results in load-dependent gear losses (P_{VZP}). Churning losses, squeezing losses, impulse losses and ventilation losses are related to the oil flow in the gearbox (Ref. 18). They are referred to as no-load gear losses (P_{VZ0}) as they are almost independent from the applied load.

In terms of an efficiency calculation, values for every single one of the named forms of power loss are needed in as much detail as possible. Thus, a lot of research focuses on the formulation of calculation models to quantify load-dependent and no-load losses. The following two subsections present common and recent calculation models for predicting load-dependent and no-load gear losses of worm gears.

Load-dependent gear losses. The load-dependent gear losses P_{VZP} correlate to the friction between meshing tooth flanks. According to DIN 3996:2019-09 (Ref. 9), it can be described as (DIN 3996:2019-09 (Ref. 9) simplifies $\frac{2\pi}{60}$ by 0.1):

$$P_{VZP} = \underbrace{\frac{2 \cdot \pi}{60}}_{\approx 0.1} \cdot \frac{T_2 \cdot n_1}{u} \cdot \left(\frac{1}{\eta_z} - 1 \right) \quad (3)$$

Since worm gears show different gear losses, depending on the direction of the power flow, the calculation of the meshing efficiency η_z must be considered separately. When the worm shaft is driving, according to DIN 3996:2019-09 (Ref. 9), Eq. (4) is used:

$$\eta_z = \frac{\tan(\gamma_m)}{\tan(\gamma_m + \arctan(\mu_{mz}))} \quad (4)$$

When the worm wheel is driving, the efficiency is generally lower. Furthermore, a self-locking effect can occur in this operation mode if the meshing efficiency η_z is less than 0.5. According to DIN 3996:2019-09 (Ref. 9), Eq. (5) is applied:

$$\eta_z' = \frac{\tan(\gamma_m - \arctan(\mu_{mz}))}{\tan(\gamma_m)} \quad (5)$$

With regard to Eqs. (3-5), beside geometrical and operational data as gear ratio u , worm wheel torque T_2 , worm shaft drive speed n_1 and pitch angle of the worm γ_m , the calculation of the load-dependent gear losses comes down to the mean

coefficient of friction μ_{mz} .

The mean coefficient of friction μ_{mz} represents the complex friction characteristic of meshing tooth flanks by one single mean value. In terms of worm gears, there are currently two different approaches and calculation models available. DIN 3996:2012-09 (Ref. 8) describes a simpler, empirical model, while Oehler et al. (Ref. 27) present a more detailed, semi-analytical one. The latter was standardized in DIN 3996:2019-09 (Ref. 9), replacing the simpler approach in DIN 3996:2012-09 (Ref. 8) very recently.

The empirical model in line with DIN 3996:2012-09 (Ref. 8) depends on a base coefficient of friction μ_{0T} multiplied by the size factor Y_s , geometry factor Y_G , material factor Y_W and roughness factor Y_R . Based on a reference gearbox, these factors take the deviation of the actual gearbox into account:

$$\mu_{mz} = \underbrace{\mu_{0T}}_{f(a)} \cdot \underbrace{Y_s}_{f(h^*)} \cdot \underbrace{Y_G}_{f(\text{material})} \cdot \underbrace{Y_W}_{f(Ra)} \cdot \underbrace{Y_R}_{f(Ra)} \quad (6)$$

The base coefficient of friction μ_{0T} is another empirical value that depends on the sliding velocity v_{gm} , the oil type and the material of the worm wheel:

$$\mu_{0T} = f(v_{gm}, \text{oil type, material}) \quad (7)$$

The semi-analytical model by Oehler et al. (Refs. 9, 27) considers notable more calculation parameters, and is overall a more precise model from a physical perspective. The mean coefficient of friction μ_{mz} is based on the concept of load sharing dividing into a boundary coefficient of friction μ_{Gr} and fluid coefficient of friction μ_{Fl} .

$$\mu_{mz} = \psi \cdot \mu_{Gr} + (1 - \psi) \cdot \mu_{Fl} \quad (8)$$

The solid load portion ψ depends on the relative lubricant film thickness λ , which can be calculated by dividing the minimal mean lubrication gap thickness $h_{min,m}$ according to DIN 3996:2019-09 (Ref. 9) and the quadratic mean roughness $Rq_{1,2}$ of the contacting meshing partner.

$$\psi = f(\lambda) \text{ with } \lambda = f(h_{min,m}, Rq_{1,2}) \quad (9)$$

The boundary coefficient of friction μ_{Gr} relates to solid asperity contacts of the gear flanks. Oehler et al. (Ref. 27) investigated the behavior of boundary friction experimentally and derived oil type-specific, simplified formulae, which describe the boundary coefficient of friction μ_{Gr} as function of the mean flank pressure σ_{Hm} according to DIN 3996:2019-09 (Ref. 9):

$$\mu_{Gr} = f(\sigma_{Hm}) \quad (10)$$

The fluid coefficient of friction μ_{Fl} relates to shearing of the fluid. The influence parameters are the shear stress of the fluid τ_{Fl} , the mean flank pressure σ_{Hm} as well as the solid load portion. To calculate the fluid shear stress, Oehler et al. (Ref. 25) use a limiting shear stress flow model of Bair and Winer model according to (Ref. 1).

$$\mu_{Fl} = f(\tau_{Fl}(\tau_{lim}, \eta_m, v_{gm}, h_{min,m}) \sigma_{Hm}, \psi) \quad (11)$$

No-load gear losses. Currently, no specific, validated calculation model is available for the no-load gear losses P_{VZ0} of worm gears. Even though DIN 3996:2012-09 (Ref. 8) offers an

equation for calculating the overall no-load loss of gearboxes with worm gears, it does not differentiate between the different power loss portions, as there are the gears, bearings and seals. Therefore, from a more gear component-specific perspective, this does not meet the requirements of a detailed analysis of the efficiency and heat balance of gearboxes with worm gears. This is in accordance with DIN 3996:2019-09 (Ref. 9), where this approach was removed.

Calculating the no-load bearing losses, as well as the seal losses, and subtracting them from calculated overall no-load loss according to DIN 3996:2012-09 (Ref. 8) does, theoretically, lead to the no-load gear loss of worm gears, but in practice, this is not useful. Also, calculations show that depending on the operating point, this may result in a negative no-load gear loss due to high calculated no-load bearing losses, which does not make sense.

Oehler et al. (Ref. 27) used a calculation model for churning losses of spur gears and transferred it to worm gears as shown in Eqs. (12–13). They used the model developed by Changenet et al. (Ref. 5), which can, theoretically, be applied to other types of gears:

$$P_{VZ0} = \left(\frac{1}{2} \cdot \rho_{oil} \cdot \left(\frac{\pi \cdot n_i}{30} \right)^2 \cdot A \cdot \left(\frac{d_m}{2} \right)^3 \cdot C_m \right) \omega_i \quad (12)$$

$$C_m = \left(\frac{2 \cdot h_D}{d_m} \right)^{0.45} \cdot \left(\frac{V_0}{d_m} \right)^{0.1} \cdot \left(\frac{\omega_i^2 \cdot d_m}{2 \cdot g} \right)^{-0.6} \cdot \left(\frac{\omega_i \cdot d_m^2}{4 \cdot v} \right)^{-0.21} \cdot \left(\frac{Fr}{Re} \right) \quad (13)$$

Oehler et al. (Ref. 27) points out that using this model may lead to uncertainties and minor miscalculations. For lack of a better solution, this may currently be the most precise calculation model for no-load gear losses of worm gears.

Bearing losses. Relative movement between the inner and outer bearing ring as well as the cage and rolling elements causes power losses within bearings. Schleich (Ref. 33) divides bearing losses into four main causes: rolling friction, sliding friction, inner friction of the lubricant and ventilation losses, which can be determined by several existing calculation models.

For example, the bearing manufacturers SKF (Ref. 36) (Eq. (14)) and Schaeffler/INA/FAG (Ref. 32) (Eq. (15)) provide simple empirical calculation models specifically for their bearing designs. Both models are based on the addition of no-load and load-dependent bearing losses.

$$P_{VL,SKF} = \left(\underbrace{T_r + T_{sl}}_{T_{VLP}} + \underbrace{T_{seal} + T_{drag}}_{T_{VLO}} \right) \cdot 2 \cdot \pi \cdot n \quad (14)$$

$$P_{VL,INA} = (T_{VLO} + T_{VLP}) \cdot 2 \cdot \pi \cdot n \quad (15)$$

More comprehensive approaches that take into account the stiffness and local friction calculation can be found in the method of Wang (Ref. 39), implemented in the simulation program *LAGER2* (Ref. 17), and the local friction model developed by Schleich (Ref. 33), which is based on the addition of the torque losses of the individual rolling elements. Since the calculation is local in nature, many input parameters are needed.

A powerful and complex commercial program is *Bearinx* by Schaeffler (Ref. 31).

Seal losses. Seal losses can be calculated according to ISO/TR 14179-2:2001-08 (Ref. 13), in which losses are dependent on the shaft diameter d_{sh} as well as the shaft rotation speed n :

$$P_{VD} = 7.69 \cdot 10^{-6} \cdot d_{sh}^2 \cdot n \quad (16)$$

Eq. (16) only covers radial shaft seals, which means that mechanical seals cannot be calculated, for instance. According to ISO/TR 14179-2:2001-08 (Ref. 13), non-contacting seals result in almost no power loss.

Temperature Calculation

Since temperature influences oil viscosity, which greatly affects the power loss of a gearbox, a temperature calculation model is required for an automatic and precise efficiency calculation. Since a gearbox shows local differences in temperature, it is reasonable to not only calculate a mean temperature for the whole gearbox but also specific local temperatures of the single components. This local heat balance analysis not only provides an opportunity to predict the thermal load capacity, but also to detect hot spots inside a gearbox. Using a TNM makes it possible to determine component temperatures in gearbox systems.

When the TNM is used, a system is divided into isothermal parts represented by nodal points. Depending on the structure of the system, those nodal points are linked where needed, considering a thermal resistance between them. Finally, a network comparable to an electrical circuit builds up what makes the transfer of the well-known mathematical laws of Ohm possible:

$$U = R_{ohm} \cdot I \rightarrow \Delta T = R_{th} \cdot \dot{Q} \quad (17)$$

Rearranging Eq. (17) and replacing the thermal resistance R_{th} with the thermal conductance L forms the base equation for the thermal calculation:

$$\dot{Q} = \Delta T \cdot L \text{ with } R_{th} = \frac{1}{L} \quad (18)$$

Eq. (18) applies to every linked pair of nodes, meaning that whenever a difference in temperature ΔT exists between those nodes, the rate of heat flow \dot{Q} depends on the thermal conductance L .

Similarly to electrical circuits, another principle of thermal networks is heat and power balance for every node. This means that the sum of all heat flow \dot{Q} and power P flowing towards a node i must run off again for a stationary state:

$$\sum \dot{Q}_{in,i} + P_i = \sum \dot{Q}_{out,i} \quad (19)$$

Rearranging and using Eq. (19) with Eq. (18) and putting it into the context of a thermal network with n nodes, an expression for the temperature calculation of each node can be formulated:

$$P_i - \sum_{j,j \neq i}^n (T_i - T_j) \cdot L_{ij} = 0 \quad (20)$$

When expressed as a matrix, Eq. (20) contains $n - 1$ linearly independent equations and a single boundary condition,

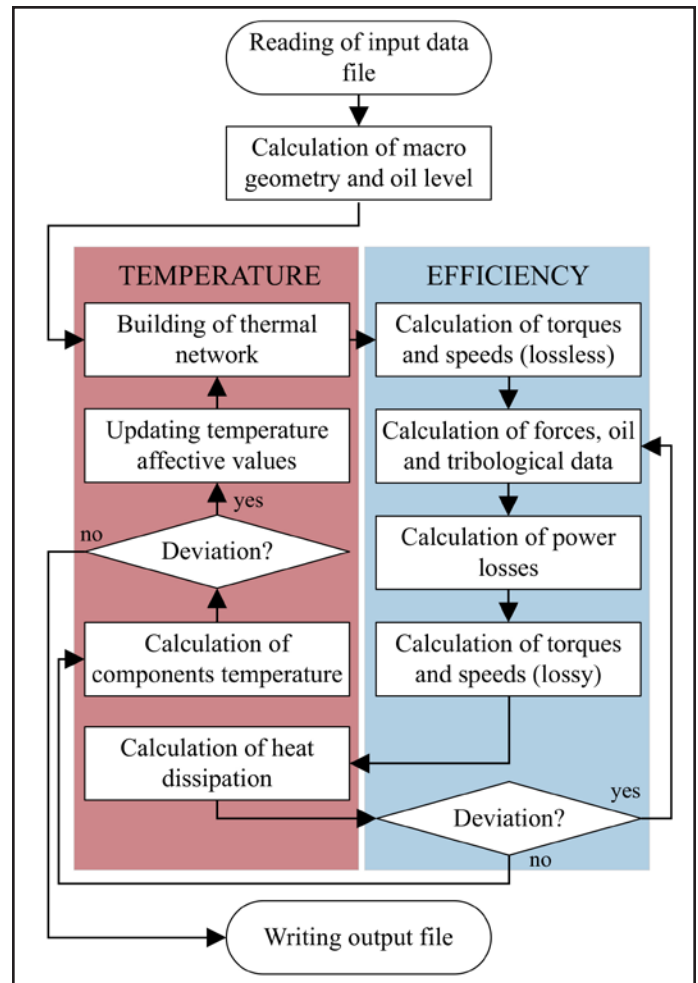

Figure 2 Flowchart of efficiency and heat balance simulation.

making it suitable for numerical solution. This formulation of an efficient, suitable thermal network is needed when it comes to an automatic and precise calculation of the efficiency and heat balance of gearboxes.

Implementation in Simulation Program

The efficiency and temperature calculation described in Sects. 3 and 4 appropriate to gearboxes with worm gears is customized and implemented in the simulation program *WTplus* (Ref. 16), which is currently applicable to gearbox systems containing cylindrical and bevel gears. *WTplus* uses routines for the calculation of the efficiency and heat balance (Fig. 2). Initially, a routine reads the input data followed by the macro geometry and parameter calculation according to (Refs. 7–8). Where necessary, data is automatically complemented. *WTplus* then calculates the efficiency (blue) and heat balance (red) iteratively. If the calculation results in enough exactitude, an output file containing all relevant data is generated. The efficiency and temperature calculation, as well as the required extensions for gearboxes with worm gears, are described in the following Sections.

Efficiency calculation. The simulation program calculates all torques and speeds, including a power flow analysis, according to Stangl (Ref. 37). Initially, these torques and speeds are not affected by any losses (*loss-less*) but are only

dependent on the kinematics of the gearing system.

Next, with the torques and speeds known, forces caused by the tooth system of worm gears can be calculated according to DIN 3996:2019-09 (Ref. 9). Subsequently, the tooth system forces are put into shaft-bearing context and thus the simulation program determines the reactive bearing forces. Then, oil data as viscosity and density is calculated to determine the tribological factors (see previous sections). Considering these values, the specific power loss portions of gears, bearings and seals are computed (see previous sections).

Lastly, the simulation program calculates all torques and speeds again, but this time it takes into consideration power losses that reduce the torques (*lossy*). Since these reduced torques change the tooth system forces, this leads to different bearing forces and thus changed power losses. Therefore, an iterative solution must be considered, comparing the output torques of two subsequent iterations. If the deviation between those results is below a given limit, efficiency is considered solved and the temperature calculation begins.

Local temperature calculation. The simulation program is not only able to solve the oil temperature, but can also solve local temperatures of single components fully automatically, based on the TNM explained previously.

It is notable that the thermal network is built up fully automatically, abstracting the gearbox by suitable nodalization, linking those nodes and calculating necessary thermal conductance. The following explains the process of the abstraction for worm gears and shows solutions for the calculation of thermal conductance.

Nodalization. The gearbox with its gears, shafts, bearings, housing and oil is considered a system, which is nodalized. The housing is considered an isothermal body, and thus abstracted by a single node. It is linked to the environment, oil and bearings. The environment acts as a boundary condition in the form of a heat sink with a specified temperature. The oil sump is assumed to be isothermal and thus is abstracted by a single node — like the housing. Hence, the effect of temperature differences due to oil flow is neglected. Funck (Ref. 10) investigated the heat balance of gearboxes and derived formulae to describe the thermal behavior of the gearbox housing and oil sump.

Schleich (Ref. 33) investigated the thermal behavior of bearings using a thermal network. Due to uncertainties and several assumptions, he concludes that dividing bearings into their components represented by a thermal network is challenging. Therefore, bearings are simplified and a single node assuming a mean temperature of the bearing is used.

Regarding shafts, Geiger (Ref. 11) shows the need to divide long narrow bodies suitably into several isothermal sections in order to minimize calculation errors and preserve compact network size. In terms of axial distance, the width of an isothermal section is set accordingly, as less than or equal to its shaft diameter. Furthermore, the simulation program generates a new isothermal section wherever a component (bearing or gear) or a diameter change of the shaft is located (Fig. 3).

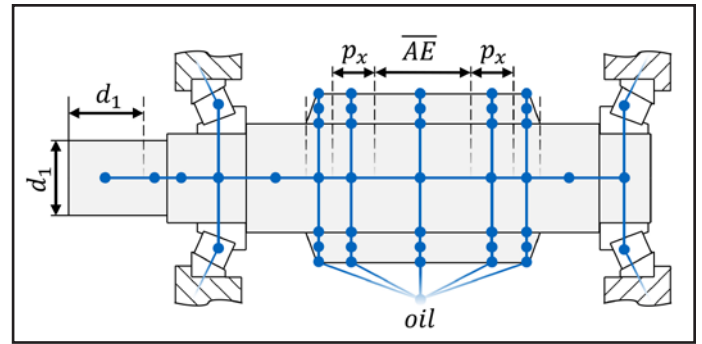

Figure 3 Distribution of nodes for a worm shaft (schematically).

Regarding the gears, it is reasonable to subdivide them into the gear body, teeth and tooth flanks. Two-piece worm wheels, as are often used, can be considered by abstracting the wheel hub and sprocket by discrete nodes. Overall, the refinement of the gears allows a more detailed resolution of the temperature.

Since the tooth system of a worm gear is extended in an axial direction, it is divided into sections similarly to the shafts. The determining parameters are the contact length \overline{AE} and axial pitch p_x according to DIN 3975-1:2017-09 (Ref. 7). It is assumed, that the section determined by the contact length \overline{AE} lies in the middle of the tooth system representing the area of tooth contact. It can be calculated by an empirical model (Ref. 35). Since the tooth system of worm gears is usually longer than the contact, the remaining area is divided equally into a section of a maximal length of the axial pitch p_x (Fig. 3). This subdivision allows a more refined resolution of the heat distribution within the tooth system, compared to the use of a single node.

Calculation of thermal conductance. Besides building the structure of the thermal network by a suitable abstraction of the components and reasonable linking, the determination of the thermal conductance L between nodes is essential (Eq. (18)). Driven by a difference in temperature ΔT , the heat transfer between linked nodes is based on the physical mechanisms conduction, convection and radiation. Depending on the mechanism and the boundary conditions, a heat transfer coefficient α is established. Multiplied by the interacting surface A , the thermal conductance L can be calculated:

$$L = \alpha \cdot A \tag{21}$$

In order to describe the conditions between nodes (e.g. — shaft↔shaft, shaft↔bearing, shaft↔gear body, etc.), simple analogue models such as *heat transfer through a plain wall* or *heat transfer through a cylinder* are used in line with Greiner (Ref. 12) wherever possible. If not applicable, substitute models are taken.

In the following, the distribution of the load-dependent gear loss to the contacting meshing partners and the calculation of thermal conductance between tooth flank↔oil and tooth flank↔tooth body are explained in more detail.

Distribution of Load-Dependent Gear Loss between Gears

Apparent power loss is fully converged to heat. Thus, the load-dependent gear loss is modelled as a heat source located between the tooth flanks of the contacting meshing partners. According to the model based on (Refs. 2, 30), the heat is distributed proportionally to the tangential velocities $v_{1,2}$ and material parameters $b_{1,2}$ of the contact partners:

$$\frac{\dot{Q}_1}{\dot{Q}_2} = \sqrt{\frac{v_{11} \cdot b_1}{v_{12} \cdot b_2}} \text{ where } \dot{Q}_1 + \dot{Q}_2 = P_{VZP} \quad (22)$$

$$\text{with } b_{1,2} = \sqrt{\lambda_{1,2} \cdot \rho_{1,2} \cdot c_{1,2}} \quad (23)$$

Due to the high sliding speeds and thus high tangential velocities in worm gears, a typical heat distribution is about $\dot{Q}_1/\dot{Q}_2 \approx 0.8/0.2$, whereas for spur gears the heat distribution is about up to $\dot{Q}_1/\dot{Q}_2 \approx 0.6/0.4$.

Since the contact line of the meshing gears is diametrically changing as it travels from the tooth root to the tooth tip, and thus the sliding velocity is changing, 100 different meshing positions are calculated as per Eq. (22), and subsequently averaged. This allows the specific changing sliding velocity to be considered.

Thermal conductance tooth flank ↔ oil. When the gearbox is dip-lubricated, a model is needed to calculate thermal conductance between the tooth flank and oil. Since the worm shaft and worm wheel have fundamentally different geometries, distinct models are used depending on the gear in question.

With regard to the worm shaft, a Nusselt correlation of a rotating cylinder according to Changenet et al. (Ref. 4) is used in order to determine the heat transfer coefficient α :

$$\alpha = \frac{Nu \cdot \lambda}{l} \quad (24)$$

$$\text{with } Nu = 0.133 \cdot Re^{2/3} \cdot Pr^{1/3} \quad (25)$$

$$\text{with } Re = \frac{l \cdot d_m}{\nu} \quad (26)$$

$$\text{with } Pr = \frac{v \cdot \rho \cdot c}{\lambda} \quad (27)$$

The interacting surface A is assumed by a simplified surface of the worm shaft consisting of the teeth tip surface (a), teeth flank surface (b) and teeth root surface (c) (Fig. 4). Since the rotation of a simplified cylinder surface will cause less turbulence in the oil than the actual geometry of the worm shaft, an

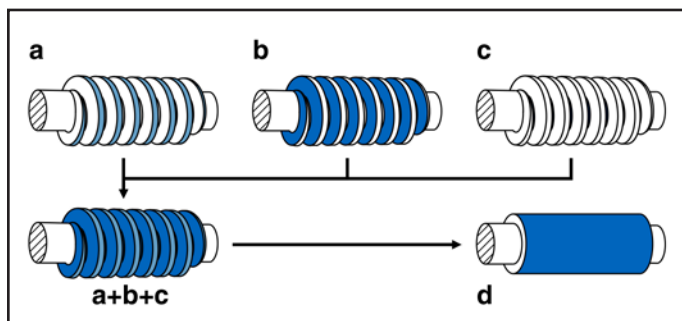

Figure 4 Simplified surface of the worm shaft (d) consisting of teeth tip surface (a), teeth flank surface (b) and teeth root surface (c).

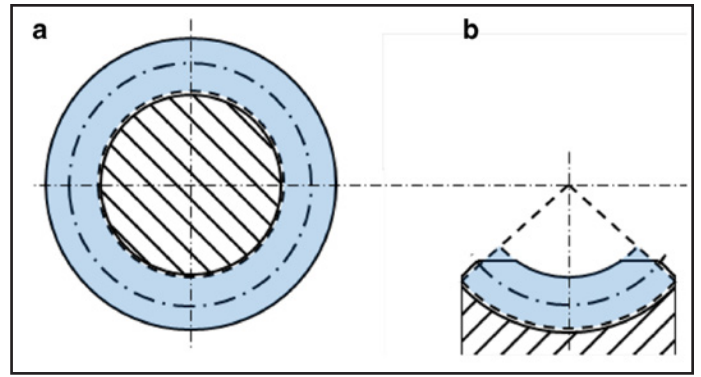

Figure 5 Assumed active tooth surface of the worm shaft (a) and the worm wheel (b).

underestimation of the heat transfer coefficient is expected.

According to Changenet et al. (Ref. 4), the thermal conductance between the worm wheel tooth flank and the oil is approached by Blok's centrifugal flying-off theory:

$$L = \frac{2 \cdot \pi \cdot \sqrt{b}}{F \cdot l \cdot 2 \cdot z \cdot h_{ID} \cdot \lambda \cdot \omega \cdot \sqrt{\tau}} \quad (28)$$

$$\text{with } F = \begin{cases} 1.14 & \psi < 0.68 \\ (1.55 - 0.6 \cdot \psi) & 0.68 < \psi < 1.5 \end{cases} \quad (29)$$

$$\text{with } \psi = \left(d_w \cdot b \cdot \frac{(\omega \cdot \tau)^2}{2 \cdot h \cdot v} \right)^{1/4} \quad (30)$$

Thermal conductance tooth flank ↔ tooth. The thermal conductance between the tooth flank and the tooth body can be described using the analogue model of *heat transfer through a plain wall*. The interacting surface is represented by the effective tooth surface A_{eff} . It is calculated by the active tooth surface A_{act} multiplied by a factor depending on the gear ratio.

Depending on the gear in question, the active tooth surface is the assumed cumulated tooth contact surface during meshing of either the worm shaft or wheel (cf. Fig. 5).

Since the worm shaft and the worm wheel have a different number of teeth, a single tooth passes the contact more or less frequently, depending on the gear under consideration. Using the worm shaft as a reference, the teeth of the worm wheel pass the contact less frequently. This means that the time for heat dissipation is greater, which can equally be seen as the transferred heat being distributed over a larger surface. Seitzinger (Ref. 34) investigates the heating of spur gears and develops a simple empirical model that considers this particular issue, using a single factor depending on the gear ratio u . In the simulation program, Eq. (31) is used:

$$A_{2,eff} = \frac{A_{2,act}}{1 + 0.11 \cdot (u - 1)^2} \quad (31)$$

A more detailed explanation of the build of a worm gear's thermal network is found in (Ref. 28).

Results

The efficiency and heat balance model developed was validated by numerous measurements of different worm gearboxes with different center distances a from 40 to 200mm and gear ratios u from 5 to 63.

Heat balance calculations were performed using the TNM, taking into account the nodalization and determination of thermal conductances, as shown previously.

With regard to efficiency, both the empirical and semi-analytic model described earlier are compared with measurements. Figure 6 shows that the simulation and measurement results are very close to each other. Eighty-two percent of the simulation results lie within a deviation of less than ten percent, which is illustrated by the dashed line.

Figure 7 displays simulated and measured component temperatures of five different gearboxes. Some environmental

influences including ambient temperature, temperature and speed of cooling airflow, as well as gearbox foundation are estimated due to lack of detailed input data. Nevertheless, calculation results correspond closely to the measurements.

Summary

In this study, a simulation method was developed to determine the efficiency and heat balance of gearboxes with worm gears, and integrated into the simulation program *WTplus*. First, the general context of power loss and heat balance calculation of gearboxes was shown. Then, calculation models for the component-specific determination of power losses in worm gearbox were shown as well as the use of an automatically building thermal network for heat balance calculation. The application of the thermal network to a worm gearbox was presented afterwards, including the nodalization and calculation of important thermal conductance. Simulation results of the efficiency calculation and heat balance calculation showed very good correlation with measurements. **PTE**

This paper was first published on 27.01.2020 in Forschung im Ingenieurwesen (<https://doi.org/10.1007/s10010-019-00390-1>) as Open Access and licensed under a Creative Commons Attribution 4.0 International License (<http://creativecommons.org/licenses/by/4.0/>). It is republished here without changes.

For more information.

Questions or comments regarding this paper? Contact Constantin Paschold at paschold@fzg.mw.tum.de.

References

1. Bartel, D. (2010) "Simulation von Tribosystemen – Grundlagen und Anwendungen," Vieweg+Teubner Verlag / GWV Fachverlage GmbH Wiesbaden, Wiesbaden.
2. Blok, H. (1969) "The Present Status of the Theory of Gear Lubrication," Vorlesungsskript, Delft
3. Bouché, B. (1991) "Reibungszahlen von Schneckengetriebeverzahnungen im Mischreibungsgebiet," Dissertation, Ruhr Universität Bochum, Bochum.
4. Changenet C., X. Oviedo-Marlot and P. Velex. (2006) "Power Loss Predictions in Geared Transmissions Using Thermal Networks-Applications to a Six-Speed Manual Gearbox," *Tribol Trans* 128(3):618.
5. Changenet C. and M. Pasquier. (2002) "Power Losses and Heat Exchange in Reduction Gears: Numerical and Experimental Results," *International Conference on Gears*, International conference March, Düsseldorf, vol 2002, pp 13–15.
6. Chen L.F., X.L. Wu, D.T. Qin and Z.J. Wen. (2011) "Thermal Network Model for Temperature Prediction in Planetary Gear Trains," *Appl Mech Mater* 86:415–418.
7. DIN 3975-1:2017-09. Begriffe und Bestimmungsgrößen für Zylinder-Schneckengetriebe mit sich rechtwinklig kreuzenden Achsen – Teil 1: Schnecke und Schneckenrad (2017).
8. DIN 3996:2012-09. Tragfähigkeitsberechnung von Zylinder-Schneckengetrieben mit sich rechtwinklig kreuzenden Achsen (2012).
9. DIN 3996:2019-09. Tragfähigkeitsberechnung von Zylinder-Schneckengetrieben mit sich rechtwinklig kreuzenden Achsen (2019).
10. Funck, G. (1985) "Wärmeabführung bei Getrieben unter quasistationären Betriebsbedingungen," Dissertation, Technische Universität München, München.
11. Geiger, J. (2015) "Wirkungsgrad und Wärmehaushalt von Zahnradgetrieben bei instationären Betriebszuständen," Dissertation, Technische Universität München, Garching.
12. Greiner, J. (1990) "Untersuchungen zur Schmierung und Kühlung einspritzgeschmierter Stirnradgetriebe," Dissertation, Universität Stuttgart, Stuttgart.
13. ISO/TR 14179-2:2001-08. Zahnradgetriebe – Wärmehaushalt (2001).
14. Kakavas, I. and A. V. Olver. d. Dini: Hypoid gear vehicle axle efficiency, *Tribology International* 101, S. 314–323 (2016).

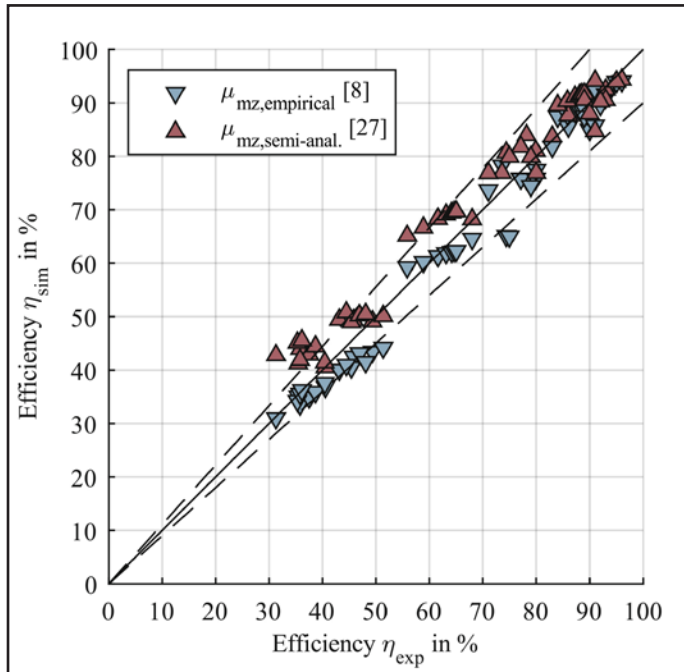

Figure 6 Comparison of experimental and simulated efficiency data of different worm gearboxes and operating points.

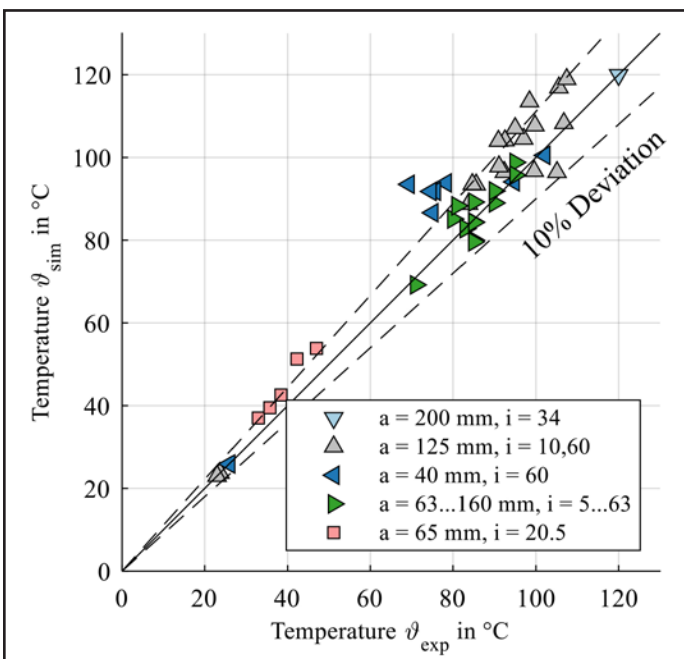

Figure 7 Comparison of measured and simulated component temperatures of different worm gearboxes.

15. Kipp, B. (2008) "Analytische Berechnung thermischer Vorgänge in permanentmagnetregten Synchronmaschinen," Dissertation, Helmut-Schmidt-Universität, Hamburg.
16. Kurth, F., J. Geiger, M. Sedlmair and M. Stangl. (2016) FVA-EDV Programm *WTplus* – Benutzeranleitung, Forschungsvereinigung Antriebstechnik (FVA) e.V., Frankfurt am Main.
17. Leonhardt, C., M. Otto and K. Stahl. (2016) FVA 364V – Lebensdauer-Industriegetriebe-Wälzlager – Erweiterung von LAGER2 zur Dimensionierung von Wälzlagern in Industriegetrieben: Mechanische Kontaktgrößen und Tragfähigkeitskennwerte, Abschlussbericht, Frankfurt am Main.
18. Liu, H., T. Jurkschat, T. Lohner and K. Stahl. (2018) "Detailed Investigations on the Oil Flow in Dip-Lubricated Gearboxes by the Finite Volume CFD Method," *Lubricants* 6(47), <https://doi.org/10.3390/lubricants6020047>.
19. Liu, Y., J. Peng, B. Wang, D. Qin and M. Ye. (2018) "Bulk temperature prediction of a two-speed automatic transmission for electric vehicles using thermal network method and experimental validation," *Proc Inst Mech Eng Part D: J Automob Eng* 101(3):2585–2598.
20. Magyar, B. (2012) "Tribo-dynamische Untersuchungen von Zylinderschneckengetrieben," Dissertation, Technische Universität Kaiserslautern, Kaiserslautern.
21. Mautner, E. M., W. Sigmund, J.P. Stemplinger and K. Stahl. (2016) "Efficiency of worm gearboxes," *Proc Inst Mech Eng Part C: J Mech Eng Sci* 230(16):2952–2956.
22. Monz, A. (2012) "Tragfähigkeit und Wirkungsgrad von Schneckengetrieben bei Schmierung mit konsistenten Getriebefetten," Dissertation, Technische Universität München, Garching.
23. Niemann, G. (1942) "Schneckenriebe mit flüssiger Reibung – Abhängigkeit der übertragbaren Leistung und des Reibwertes von Zahnform, Abmessung, Drehzahl und Schmierfähigkeit," *VDI-Verlag*, Berlin.
24. Niemann, G. and H. Winter. (1983) *Schraubrad-, Kegelrad-, Schnecken-Ketten-, Riemen-, Reibradgetriebe, Kupplungen, Bremsen, Freiläufe*, 2nd edn. *Maschinenelemente*, vol 3. Springer, Berlin, Heidelberg.
25. Oehler, M., B. Magyar and B. Sauer. (2017) "Ein neuer, normungsfähiger Berechnungsansatz für den Wirkungsgrad von Schneckengetrieben."
26. Oehler, M., B. Magyar and B. Sauer. (2018) "Gekoppelte thermische und tribologische Analyse von Schneckengetrieben Tribol Schmierungstechnik" 65(1):54–60.
27. Oehler, M, B. Magyar and B. Sauer. (2016) IGF-Nr. 18275N, FVANr. 729 I, Schneckengetriebewirkungsgrade – Schneckengetriebewirkungsgrade, Abschlussbericht, Frankfurt am Main.
28. Paschold, C. (2018) FVA-Nr. Thermische Betrachtung von Schneckengetrieben in *WTplus*, Abschlussbericht, Frankfurt am Main (69 VII).
29. Predki, W. (1982) "Hertzische Drücke, Schmierstauhöhen und Wirkungsgrade von Schneckengetrieben," Dissertation, Ruhr Universität Bochum, Bochum.
30. Reißmann, J. and H. Plote. (1996) "Blitztemperatur – Thermodynamik der Wälz-Gleit-Paarungen," Abschlussbericht, Frankfurt am Main.
31. Schaeffler Technologies AG & Co. KG: BEARINX-online Wellenberechnung. URL: https://www.schaeffler.de/content.schaeffler.de/de/produkte-und-loesungen/industrie/berechnung-und-beratung/berechnung/bearinx_online_shaft_calculation/index.jsp, Accessed: 9 May 2019.
32. Schaeffler Technologies AG & Co. KG (2015) *Wälzlagerpraxis – Handbuch zur Gestaltung und Berechnung von Wälzlagerungen*. Vereinigte Fachverlage, Mainz.
33. Schleich, T.J. (2013) "Temperatur- und Verlustleistungsverhalten von Wälzlagern in Getrieben," Dissertation, Technische Universität München, München.
34. Seitzinger, K. (1971) "Die Erwärmung einsatzgehärteter Zahnräder als Kennwert für ihre Freitragfähigkeit," Dissertation, Technische Universität München, Garching.
35. Sirtsyn, A.I. and G.V. Minervin. (1981) "Determination of the engagement factor of a worm gear," *Vestnik Mashinostroeniya* 61(10):23–26.
36. SKF. The SKF model for calculating the frictional moment. https://www.skf.com/binary/21-299767/TheOSKF0modelofor0calculating0the0frictional0movement_tcm_12-299767.pdf, Zugriffen: 04.09.2019.
37. Stangl, M. (2007) "Methodik zur kinematischen und kinetischen Berechnung mehrwelliger Planeten-Koppelgetriebe," Dissertation, Technische Universität München, Garching.
38. Sucker, J. (2013) "Entwicklung eines Tragfähigkeitsberechnungsverfahrens für Schraubradgetriebe mit einer Schnecke aus Stahl und Forsch Ingenieurwes," (2020) 84:115–125 125 einem Rad aus Kunststoff, Dissertation, Ruhr Universität Bochum, Bochum.
39. Wang, D. and G. Poll. (2012) FVV-Nr. 609812, "Low Friction Powertrain – G2.1 Wirkungsgradoptimiertes Getriebe," Abschlussbericht, Forschungsvereinigung Verbrennungskraftmaschinen (FVV) e.V., Frankfurt am Main.
40. Weber, C., W. Maushake and G. Niemann. (1956) Untersuchung von Zylinderschneckengetrieben mit rechtwinklig sich kreuzenden Achsen – "Bericht 125 der Forschungsstelle für Zahnräder und Getriebebau Technische Hochschule München," *Vieweg+Teubner Verlag*, Wiesbaden.
41. Wilkesmann, H. (1974) "Berechnung von Schneckengetrieben mit unterschiedlichen Zahnprofilformen – Tragfähigkeit und Verlustleistung für Hohlkreis-, Evolventen- und Geradenlinienprofil," Dissertation, Technische Universität München, München.
42. Xiao, H, D. Tang, Z. Deng, C. Li, F. Kong and S. Jiang. (2017) "Thermal analysis and experimental verification of the transmission in a lunar drilling system," *Appl Therm Eng* 113:765–773.

For Related Articles Search

worm gears

at www.powertransmission.com

Constantin Paschold studied Automotive and Combustion Engine Technology at the Technical University of Munich (TUM). During his Master's program he did research in the area of the calculation of efficiency and heat balance of worm gears. After he had finished his Master's degree in 2017, he joined the Gear Research Centre (FZG) as a research associate. Paschold is focusing on the calculation of efficiency and heat balance of gearboxes and software development.



Martin Sedlmair finished his Master's program in Mechanical Engineering and Management at the Technical University of Munich (TUM) in 2014. Afterwards, he joined the Gear Research Centre (FZG) as a research associate. Since March 2018, Sedlmair is team leader in the field of Gearbox Efficiency and Oilflow in the department for EHL-Tribological-Contact and Efficiency.



Thomas Lohner studied Mechanical Engineering and joined the Gear Research Centre (FZG) at the Technical University of Munich (TUM) as a research associate in 2012. Since finishing his Dr.-Ing. degree in 2016, he has worked as post-doctoral fellow and is head of the department EHL-Tribological-Contact and Efficiency at FZG. Lohner's research interests include machine elements, gears and power transmission systems, as well as tribology, elastohydrodynamic lubrication, efficiency and heat management.



Prof. Dr.-Ing. Karsten Stahl has since 2011 been Full Professor, Institute for Machine Elements, Technical University of Munich, and the Director Gear Research Centre (FZG). He studied at the Technical University of Munich (TUM) beginning in 1989, with a focus on design and development, receiving his Final Mechanical Engineering Degree (Dr.-Ing) there in 1994. In 2001, he received his Doctorate TUM with the topic: Pitting Resistance of Carburized Spur and Helical Gears. Among his responsibilities during his Professorship: 2009–2010 — Head of Advanced Engineering and Innovation Management, Powertrain and Driving Dynamic Systems, BMW Group, Munich; 2007–2009 — Head of Validation Driving Dynamics and Powertrain, BMW Group, Oxford, UK; 2006–2007 — Head of Quality and QMT MINI Transmission, MINI Plant, BMW Group, Oxford, UK; 2003–2006 — Head of Prototyping, Gear Technology and Methods, BMW Group, Dingolfing; 2001–2003 — Development Engineer in Gear Production, BMW Group, Dingolfing; and 1994–2000 — Scientific Research Assistant (Ph.D. candidate) at Gear Research Centre (FZG), TUM. Prominent among his Professional Activities: Since 2020 DFG: Member of Review Board 402-01; 2016–2018 AiF: Member of Review Board 4. His many honors and awards include (2019) VDMA Faculty Teaching Concept Award, "Bestes Maschinenhaus"; (2019) VDMA Faculty Teaching Concept Award; and (2019) Student Award "Goldene Lehre Stahl's Editorial and many other activities include: Springer-Nature: Forschung im Ingenieurwesen, journal, Editor in Chief ASME: Journal of Vibration and Acoustics (JVA).



Rolling Bearing Performance Rating Parameters Review and Engineering Assessment

Guillermo E. Morales-Espejel and Antonio Gabelli

Nomenclature

A Constant, [-]
 A_1 Constant, [-]
 B , Constant, [-]
 a Hertzian semi-width, rolling direction, [mm]
 a_{ISO} , a_{SLF} Life modification factors, [-]
 b Hertzian semi-width, axial direction, [mm]
 b_m Rating factor for contemporary, commonly used high quality hardened bearing steel in accordance to good manufacturing practices, the value of which varies with the bearing type and design, [-]
 c Stress-life exponent, [-]
 C Dynamic load rating of a bearing, [N]
 C_0 Static load rating of a bearing, [N]
 d_m Mean diameter of the bearing, pitch diameter of rolling elements set, [mm]
 D_w Rolling element diameter in a bearing, [mm]
 e Weibull slope, [-]
 E' Combined elastic modulus in a EHL contact, [MPa]
 E Complete elliptical integral of the second kind, [-]
 F_r Radial load in the bearing, [N]
 g Gap function, [mm]
 h Exponent, [-]
 i Number of rows in the bearing, [-] / index in the FFT contact algorithm, [-]
 K Complete elliptical integral of the first kind, [-]
 k Modulus of the elliptical integrals, [-]
 l_a Effective length of the roller, [mm]
 L Bearing life in millions of revolutions, [Mrevs]
 L_x Domain length in the rolling direction for the FFT algorithm, [mm]
 L_y Domain length in the axial direction for the FFT algorithm, [mm]
 N Life in number of load cycles, [-]
 n_x Number of points along the rolling direction, [-]
 n_y Number of points along the axial direction, [-]
 p Pressure, [MPa] / exponent in the life equation, [-]
 P Equivalent load in the bearing, [N]
 p_0 Maximum Hertzian pressure in the contact, [MPa]
 P_u Fatigue load limit, [N]
 Q Contact load, [N]
 r Groove radius, [mm]
 R Radius, [mm]
 u Surface displacements in z direction, [mm] / constant to convert cycles to revolutions
 S Area in the contact algorithm, [mm²]
 w Exponent
 x Rolling direction coordinate, [mm]

y Axial direction coordinate, [mm]
 z Depth direction coordinate, [mm]
 Z Number of rolling elements in a bearing row, [-]
 α Contact angle, [deg]
 ρ Curvature, [1/mm]
 ε Eccentricity, [-]
 κ Viscosity ratio, [-]
 τ_{xz} Orthogonal shear stress in the plane x, z , [MPa]
 σ_{Hu} Fatigue limit expressed as maximum Hertzian pressure in contact, [MPa]

Subscripts

i Inner ring
 e Outer ring
 1 Surface 1, rotating
 2 Surface 2, stationary
 u Related to fatigue limit

Introduction

The main function of rolling bearings is to support load and transmit rotational movement with minimum energy loss. In order to achieve this, bearings are manufactured with particularly good quality fatigue resistance materials, proper design and tight manufacturing tolerances. Particular emphasis is put in both the macro, and micro geometry of the working shapes and surfaces of the raceways. Rolling bearings come in many types and sizes as ball and roller bearings for radial and thrust loads. For many years, the selection of the proper bearing for an application has relied on the matching of two main aspects:

1. An adequate definition of the performance rating parameters related to the actual manufacturing process and quality of the bearing, usually performed by the bearing manufacturer.
2. An adequate definition of the operating conditions and of the safety factors of the particular application, usually performed by the application engineer.

The first aspect requires: i) a quality control and assurance system during manufacturing process, and ii) a methodology for the assessment and validation of the performance parameters that are applied to bearing products. Usually this is done using load rating models that are validated by dedicated tests of the product.

The second aspect requires measurements, experimentation and good engineering knowledge of the specific application. This includes: i) dynamic load variations and transient conditions, and ii) the effect of the environment that may influence the performance of the bearing in use.

The current paper focuses on the first aspect of the

engineering selection process, critically reviewing the methodologies that are applied in bearing performance rating and their relation to bearing manufacturing quality and experimental validation.

International standards are very important here. A frequently employed standard is the ISO 281 (Ref. 1) which establishes the definitions of the dynamic load ratings of rolling bearings. This standard provides the methodology for the simple calculation of dynamic load capacity of rolling bearings based on the main geometrical parameters of the bearing and standard high quality material.

However, the standard has important limitations that users often overlook. The standard applies only to good quality bearings. In other words, bearings that represent the “status of the art” of rolling bearing manufacturing technology. In practice, this means, by quoting the standard: “*rolling bearings manufactured from contemporary, commonly used, high quality hardened bearing steel, in accordance with good manufacturing practices.*” Unfortunately, no quantitative measure of this definition of bearing quality is given in ISO 281. This, in turn, let the undifferentiated application of ISO performance parameters and dynamic load ratings to the large variety of rolling bearings that are produced today.

Verification of the ISO 281 dynamic load ratings would require the use of proper, statistically meaningful, endurance testing of rolling bearings population samples to determine the life L_{10} . However, standards of bearing endurance testing for the verification of dynamic load ratings of rolling bearings are not part of ISO or any other standard. This leads to the present situation in which bearing manufacturers typically apply ISO ratings to describe the performance of their products. However, only very few, generally well-established companies with a long tradition in quality and testing, actually verify the performance parameters of their products by means of dedicated endurance testing (Ref. 2).

Today mechanical engineers have to decide choosing a bearing among different manufacturers. In some cases, significantly different load ratings for seemingly similar bearings type and size are given without a clear explanation of the reasons behind the applied load ratings or whether or not these values are routinely supported with a quality control system and endurance testing practices. This situation is further complicated by the fact that, given the very high costs involved in bearing fatigue life testing, the results of endurance testing are usually proprietary information of the bearing manufacturer that is not released into the public domain.

This paper addresses these issues by reviewing the calculation methodologies of the most relevant load rating parameters of rolling bearings. Their definition, origin and significance in terms of fatigue life of the bearing are clarified. Verification methods of these performance parameters are also discussed. This includes the required endurance testing and the basic statistics that are used in this field.

Objective of this Paper

The intent is to critically review the most important rating parameters used in the prediction of rolling bearing performance. To discuss their origin, definitions and significance in

terms of fatigue life of the bearing. To clarify their limitations and applicability in bearing selection and machine design.

Bearing life rating parameters. Life in rolling bearings depends on many parameters and application influence, like lubrication conditions, sealing effects, solid and liquid contamination, variable loading and speed conditions, etc. However, to select the size of a bearing, rating life calculations are used. The standard ISO 281 (Ref. 1) describes the modified bearing rating life with 90% survival probability as:

$$L_{10} = a_{ISO} \left(\frac{C}{P} \right)^p \quad (1)$$

Where L_{10} is the bearing rating life for 90% survival probability, C is the dynamic load rating, P is the equivalent load in the bearing and p is a constant exponent that depends on the bearing type (3 for ball bearings and 10/3 for roller bearings). The life factor a_{ISO} is given in (Ref. 1) in dedicated charts and equations for the different lubrication and contamination conditions of the bearing. However, the basic theory comes from Ioannides et al. (Ref. 3) where a more detailed description of this life factor is given. Therefore, herewith it will not be denoted as a_{ISO} but (as in (Ref. 3) as a_{SLF} to avoid confusion with the standard:

$$a_{SLF} = \frac{A}{\left\langle 1 - \left(\eta \frac{P_u}{P} \right)^w \right\rangle^{c/e}} \quad (2)$$

With, A being a scaling constant, P_u is the fatigue limit load (C_u in ISO 281 nomenclature), is a stress penalty factor (environmental factor) described in (Ref. 2) as $\eta = \eta_a \cdot \eta_b \cdot \eta_c$. In which: η_a is a macro-scale “parasitic” stress aggravation affecting the bearing. This may be originated by: i) bearing mounting, ii) hoop tension or, iii) residual stresses from heat treatment and manufacturing processes. The factor η_b is the lubrication factor that depends on the lubrication quality κ , as defined in the ISO 281. Finally, the contamination η_c (in ISO 281 nomenclature e_c) is the stress penalty for stress concentrations developed on the bearing raceways due to solid particles contamination denting. The remaining constants of Equation (2) are the w exponent (related to the bearing type), the fatigue exponent c of the stress-life equation, and e that is the Weibull exponent.

From these two equations, the main bearing life rating parameters that depend (or may be affected) by the bearing geometry, material properties, manufacturing process and quality are C , P_u and η_a . Another important parameter, related to the maximum load safety of the bearing and its performance under low cycle fatigue, is the static load rating C_0 which will be discussed in detail later in this paper.

Dynamic Load Rating

This parameter (C) was originally invented by Lundberg and Palmgren (Refs. 4–5) when they introduced the equation of the basic rating life of rolling bearings:

$$L_{10} = \left(\frac{C}{P} \right)^p \quad (3)$$

Lundberg and Palmgren, in their work, refer to (C) as the

basic dynamic capacity of the bearing. It was defined at that time (Ref. 4) as: “the radial load (or thrust load) which 90% of the bearings can endure for one million revolutions under certain specified conditions of operation.”

ISO 281 (Ref. 1) re-writes this definition, depending on whether the bearing is radial or thrust, using the following terminology: *Basic dynamic radial/axial load rating*: “Constant stationary radial/concentric-axial load which a rolling bearing can theoretically endure for a basic rating life of one million revolutions.”

ISO 281 (Ref. 1) gives also specific equations to calculate (C_0) for each bearing type (radial or thrust, ball or roller) which are obtained from the general methodology originally developed by Lundberg and Palmgren (Refs. 4–5).

General methodology for the calculation of (C). Hereafter the study follows the same methodology of the original work of Lundberg and Palmgren (Ref. 4); this is done to arrive at an estimation of (C) before any approximations or simplifications are introduced into the equations. From the original work of Lundberg and Palmgren (Ref. 4), the dynamic load rating (C) of a rolling bearing can be calculated directly following the analytical method described in the following equations. The analysis can start by considering Equations (47) and (48) from (Ref. 4). Using the same basic nomenclature as in (Ref. 4) these equations are hereafter re-written as Equations (4) and (5).

For point contact (ball bearings).

$$\frac{Q}{D_w^2 L} \frac{3e}{c-h+2} = A_1 \varphi D_w \frac{-3(3-h)}{c-h+2} \tag{4}$$

For line contact (roller bearings).

$$\frac{Q}{D_w^2 L} \frac{2e}{c-h+1} = B_1 \psi D_w \frac{-(c-3h+5)}{c-h+1} l_a \frac{c-h-1}{c-h+1} \tag{5}$$

Furthermore, with the basic notation as from (Ref. 4), $T = \tau_0/p_0$, $\varepsilon = z_0/a$, $p_0 =$ maximum Hertzian pressure. $T_0, \varepsilon_0, T_1, \varepsilon_1$ are functions of T and ε for $a/b=0$ and $a/b=1$, respectively (a along the rolling direction, minor semi-width).

$$\varphi = \left[\left(\frac{T}{T_1} \right)^c \left(\frac{\varepsilon_1}{\varepsilon} \right)^{h-1} \frac{(D_w \Sigma \rho)^3}{\mu^{c-1} \nu^{c+h-1}} \frac{D_n u^e}{D_w} \right] \frac{-3}{c-h+2} \tag{6a}$$

$$\psi = \left[(D_w \Sigma \rho)^{\frac{c+h-1}{2}} \frac{D_n u^e}{D_w} \right] \frac{2}{c-h+1} \tag{6b}$$

$$B_1 = \left(\frac{3}{4} \right)^{\frac{c-h-1}{c-h+1}} \left(\frac{\pi}{2} \right)^{\frac{-(c-h-1)}{c-h+1}} \left(\frac{T_1}{T_0} \right)^{\frac{2c}{c-h+1}} \left(\frac{\varepsilon_0}{\varepsilon_1} \right)^{\frac{2(h-1)}{c-h+1}} \left(\frac{E'}{3} \right)^{\frac{c-h-1}{3(c-h+1)}} A_1 \frac{2(c-h+2)}{3(c-h+1)} \tag{7}$$

With $N = uL$, $\Sigma \rho =$ curvature summation used in contact theory, ν, μ Hertzian functions related to the elliptical integrals. A_1 is a proportionality constant determined experimentally from endurance testing of representative populations of rolling bearing samples. A_1 is given in the original work (Ref. 4), with bearing loads expressed in (kg) units. For bearing loads given in (N) and bearing dimensions in (mm), consistently with Equation (7) of (Ref. 6) (pages 8 and 11), one gets $A_1 = 1101.87$ and $B_1 = 1141.096$.

Notice that A_1 and B_1 need to be further updated to account for the factor b_m that was introduced in ISO in 1990, and is used in the current version of ISO 281 (Ref. 1). This will be further discussed in the next section. Detailed parameter description of Equations (6) and (7) are included in Appendix A.

It follows that if Q_c is the rolling contact load for the calculation of the dynamic load rating, from the load rating definition, the life is $L = 1$ million revolutions, then Equations (4) and (5) yield:

For point contact (ball bearings).

$$Q_c = A_1 \varphi D_w \frac{2c+h-5}{c-h+2} \tag{8}$$

For line contact (roller bearings).

$$Q_c = B_1 \psi D_w \frac{c+h-3}{c-h+1} l_a \frac{c-h-1}{c-h+1} \tag{9}$$

Based on equations (89) and (95) (Ref. 4), for the inner and outer bearing ring (inner - i , outer - e) the bearing external load P can be related to the maximum contact load Q_c as,

$$C_i = Q_c Z \cos \alpha \frac{J_i}{J_1} \tag{10a}$$

$$C_e = Q_c Z \cos \alpha \frac{J_e}{J_2} \tag{10b}$$

Where J , is the Sjövall’s radial load distribution integral.

Calculated values of this integral are given in Table 3 of (Ref. 4) depending on the bearing clearance parameter ε . Assuming a bearing with zero clearance, thus ($\varepsilon = 0.5$) one has the following values: $J_i = 0.2288$ for a single-row radial ball bearing and $J_r = 0.2453$ for a single-row radial roller bearing. The parameters J_1 and J_2 are load distribution factors that account for the load variation in the rings due to bearing rotation. For instance, refers to the rotating ring and to the stationary one. Reference 4 in Table 10 gives values for these factors as a function of the bearing clearance; for zero clearance ($\varepsilon = 0.5$) and single-row ball bearings $J_1 = 0.5625$, $J_2 = 0.5275$, and for single-row roller bearings $J_1 = 0.5965$, $J_2 = 0.6814$.

Finally, from Equation (87) (Ref. 4),

$$C = \left[1 + \left(\frac{C_i}{C_e} \right)^w \right] \frac{1}{w} C_i \tag{11}$$

Equation (11) represents the most general way of calculating the dynamic load rating of a bearing without using further simplifications, as they have been used (Ref. 4), or the additional modifications formalized in the ISO 281 (Ref. 1) standard.

All the equations discussed above were programmed in a computer code. Calculations were performed to directly determine the value of (C) for radial ball and radial roller bearings of different size and type.

ISO methodology for the calculation of (C). The ISO 281 (Ref. 1) methodology for the calculation of the dynamic load rating (C) also introduced further simplifications of the original Lundberg and Palmgren (Refs. 4–5) method, as described above; this is the most widely used methodology in industry. The main simplifications introduced by ISO are related to the calculation of the radial and axial Sjövall’s load distribution integrals J , and J_a . Some numerical values to the exponents c ,

h, w, e were also re-defined. Finally, the values of some complex type of functions are given in the form of tabulated values, or as simple heuristic functions to achieve standard ISO equations that can be quickly calculated.

In addition to this, the b_m multiplication factor was introduced in ISO in 1990. Therefore, in order to reflect the original model results, as given in (Refs. 4–5), the multiplication b_m should be set as equal to one. This factor is defined by ISO 281:2007 (Ref. 1) as: “rating factor for contemporary, commonly used, high-quality hardened bearing steel in accordance with good manufacturing practices, the value of which varies with the bearing type and design.” This factor has been used in the past to increase the dynamic load rating in order to reflect technological improvements of all kinds (Ref. 2) (material, design and manufacturing)—as shown first in the implementation of ISO 281—1977. A summary of the ISO equations for individual radial bearings is provided below. From now on, the focus of this paper will be on *radial bearings* only.

Radial ball bearings.

$$C = b_{mf} f_c (i \cos \alpha)^{0.7} Z^{2/3} D_w^{1.8}, \forall D_w \leq 25.4 \text{ mm} \quad (12a)$$

$$C = 3.647 b_{mf} f_c (i \cos \alpha)^{0.7} Z^{2/3} D_w^{1.4}, \forall D_w > 25.4 \text{ mm} \quad (12b)$$

Where $f_c = f\left(\frac{D_w \cos \alpha}{d_m}\right)$ is given in Table 2 of (Ref. 1), while Table 1 of (Ref. 1) gives b_m as 1.1 and 1.3.

Radial roller bearings.

$$C = b_{mf} f_c (i l_a \cos \alpha)^{7/9} Z^{3/4} D_w^{29/27} \quad (13)$$

Where $f_c = f\left(\frac{D_w \cos \alpha}{d_m}\right)$ is given in Table 7 of (Ref. 1), while Table 1 (Ref. 1) gives as 1.1 and 1.15.

As discussed (Ref. 7) using the above equations and a simple Vernier caliper, it is possible to quickly verify the dynamic load rating of any bearing that can be disassembled and measured. Notice that Equations (12) and (13) require all distance in [mm] with the resulting load C in N .

Calculation examples of dynamic load rating. In order to show the results from Equation (11) and to compare it with the ISO methodology, a few simple bearing cases are selected for calculation purposes. A summary of the cases and main geometrical parameters are summarized in Table 1.

The cases of Table 1 have been calculated using Equation (11) and also Equations (12) and (13). The results are

compared with the catalogue values of three well-established bearing companies; Table 2 shows this comparison. The reader should also be aware that the values quoted by the bearing manufacturers normally are rounded off using Renard series, which may introduce variability of up to $\pm 4\%$ from the exact calculated value.

Table 2 shows that, in general, calculated values with the equations from the ISO standard, Equations (12–13) are slightly higher values than Equation (11)—except for case 3, where the opposite occurs. This generally matches well the increase in the factor by ISO over the years. For instance, at the present time the standard (Ref. 1) gives $b_m = 1.3$ for cases 1 and 2 and $b_m = 1.1$ for case 3. Multiplying the values given in Equation (11) by these factors produces very similar values as the ones given by Equations (12–13). For the case of the roller bearing (case 3), there is a clear deviation (higher value) when the result of Equation (11) is compared with the results of Equations (12–13), the source of this difference is unknown, but it is suspected that it might come from the simplifications introduced by the approximated equations. However, the general methodology for the calculation of C remains valid in the present time when corrected with the b_m factor. When it comes to the values given by the different companies, bearings of similar performance class and similar dimensions and static load rating were chosen when possible. It can be seen that there are some significant differences among them, and also, in some cases, with respect to the ISO values. Inspecting the values of the dynamic load ratings of Table 2, Company 2 seems to have applied larger technology factor b_m than the ISO standard for all three cases that are examined.

For practicing engineers, the comparison shown in Table 2 is both self-explanatory and revealing. As discussed (Ref. 2), some bearing companies seem to deviate from ISO when it comes to such performance parameters as the dynamic load rating. In those cases, engineers are entitled to ask for explanations regarding the motivations that led to those deviations; as, for instance, different design, tolerances, material, and heat treatment and related confirmation of tests validating the change in load ratings. Even more important for engineers is to question the dynamic load ratings applied by recently established bearing companies which do not have endurance testing capabilities or facilities, yet quote in their catalogues the same (or higher) performance rating values as the ISO 281 standard.

Case	Designation	d_m [mm]	D_w [mm]	l_a [mm]	Z [-]	i [-]	α [deg]
1	6205	39	7.9	N.A.	9	1	0
2	7308	65	15.9	N.A.	12	1	40
3	NU 408	75	17.0	15.68	10	1	0
6205 – deep groove ball bearing			NU 408 – cylindrical roller bearing				
7308 – angular contact ball bearing							

Case	Bearing Designation	C [kN] Numerical Eq. (11)	C [kN] ISO Eqs. (12, 13)	C [kN] Company 1	C [kN] Company 2	C [kN] Company 3
1	6205	10.13	14.0	14.0	14.9	14.8
2	7308	32.35	49.3	49.0	53.0	50
3	NU 408	101.03	96.8	95.5	119.0	96.8

Fatigue Load Limit

Another important rating parameter for bearing life is the fatigue load limit, P_u (or C_u in the ISO nomenclature). This parameter was formalized and introduced for practical bearing life rating in Ioannides et al. (Ref. 3). This development followed the initial consideration of the need of a fatigue limit (stress) for bearing life calculations presented in Ioannides and Harris (Ref. 8).

The standard ISO 281 (Ref. 1) defines the fatigue load limit P_u for a complete bearing as: “The bearing load under which the fatigue stress limit, σ_w is just reached in the most heavily loaded raceway contact.” ISO 281 further specifies this limiting condition of the rolling contact as: “For rolling bearings of commonly used, high-quality material and good manufacturing quality, the fatigue stress limit is reached at a contact stress of approximately 1,500 MPa.”

For ball bearings, the contact stress can be accounted for by using Hertzian contact stress theory; thus the standard includes an analytical model for the calculation of the fatigue load limit of the bearing. In case of roller bearings, the presence of the roller profile requires the application of numerical schemes for the assessment of the maximum contact stress of the bearing; in general, a 3-D elastic contact solver is used. Given the fact that fatigue limit of the bearing material is standardized to a maximum contact pressure of 1,500 MPa (Ref. 1) for small bearings, it follows that the fatigue limit load of the bearing P_u is only a function of bearing internal geometry. Bearings from different manufacturers using similar, internal geometry and similar bearing steel material should have similar P_u .

The ISO standard (Ref. 1) adopts a definition for the fatigue limit stress of the bearing material that is expressed in term of maximum Hertzian pressure (1,500 MPa) of the rolling contacts of the bearing. The origins and validation of this value and possible variability are discussed in Gabelli et al. (Ref. 9). In addition to this basic fixed value, the standard (Appendix B) recognizes the need of a reduction of the fatigue load limit of the bearing according to increasing size. Starting with bearings that have mean diameter of 100 mm, for which the value of 1,500 MPa applies up to a penalization that varies with the rolling bearing diameter, following $(100/d_m)^{0.5}$ and $(100/d_m)^{0.3}$ for ball and roller bearings, respectively. This penalization of the fatigue load limit is introduced because bearings of large size may suffer from less manufacturing accuracy and less effective kneading of the ingots during the rolling and forging operations (Ref. 10). Reference 10 shows the details of this penalization in charts 28 and 29, where an asymptotic reduction of the fatigue limit load is indicated for a bearing mean diameter larger than 100 mm. In practice, some industries also apply specific fatigue limit reductions to increase safety, e.g. — aerospace.

General Methodology for the Calculation of P_u .

As mentioned earlier, a completely general methodology for the calculation of the fatigue load limit is pursued in this paper. In this way the calculation can be applied to ball and roller bearings alike — starting from the original basic definition of fatigue limit, as discussed in the previous section.

The methodology has two main steps. The (i) pressure in the heaviest loaded contact is calculated and set to be equal to the fatigue limit of the standard, thus the general elastic contact problem needs to be solved to find which contact load gives the specified contact stress. And (ii), knowing the load of the heaviest-loaded contact, the corresponding bearing radial load giving rise to that contact load is calculated providing the fatigue load limit — P_u of the bearing.

General elastic contact solver. There are many numerical schemes to solve the general (3-D) elastic dry contact problem, but here the FFT methodology described in (Ref. 11) is used. Since this methodology is described in detail elsewhere, only a summary is included hereafter.

Following the description (Ref. 11) for a given pressure distribution on a half-space $p(x,y)$, the surface elastic displacements $u(x,y)$ can be calculated using Fast Fourier Transform (FFT) by applying the following equation.

$$u = IFFT[w \cdot FFT(p)] \tag{14}$$

where w is a matrix containing numerical factors and is known as the frequency response function. For the elastic homogeneous problem, this matrix is calculated as follows:

$$\begin{aligned} w(1,1) &= 0 \\ w(i,j) &= \frac{1}{\sqrt{(i-1)^2 + [(j-1)l]^2}}, \forall i = 1, \dots, \frac{n_x}{2} \text{ and } j = 1, \dots, \frac{n_y}{2} \\ w(i,j) &= \frac{1}{\sqrt{(i-1)^2 + [(n_y - j + 1)l]^2}}, \forall i = 1, \dots, \frac{n_x}{2} \text{ and } j = 1, \dots, \frac{n_y}{2}, \dots, n_y \\ w(i,j) &= \frac{1}{\sqrt{(n_x - i + 1)^2 + [(n_y - j + 1)l]^2}}, \forall i = \frac{n_x}{2} + 1, \dots, n_x \text{ and } j = \frac{n_y}{2} + 1, \dots, n_y \\ w(i,j) &= \frac{1}{\sqrt{(n_x - i + 1)^2 + [(j-1)l]^2}}, \forall i = \frac{n_x}{2} + 1, \dots, n_x \text{ and } j = 1, \dots, \frac{n_y}{2} \end{aligned} \tag{15}$$

with $l = L_x/L_y$

The contact problem is solved by finding the pressures that minimize the equivalent variational statement,

$$\min(f) = \frac{1}{2} \int_S pu \, dS + \int_S pg \, dS \tag{16}$$

and

$$\frac{1}{S} \int_S p \, dS = p_{target}, p \geq 0 \tag{17}$$

Where f is the total complementary energy, g is the gap between the rigid plane, and the undeformed elastic surface.

Algorithm. The numerical algorithm employed to find the pressures from Equation (17) is also described in (Ref. 11). Beginning with a guess for the matrix that meets the equality and inequality constraints (a uniform pressure p_{target} is usually chosen as start value of the iteration process), then —

1. Calculate a candidate pressure matrix $p' = p - \text{grad}[f(p)]$. In general, p' will violate the constraints $\text{grad}[f(p)] = u(p) + g$ for f quadratic.
2. Shift p' uniformly up or down so that the sum of the positive pressures equals the target load.
3. Truncate all $p' < 0$ thus, p' meets all constraints.
4. Set $p = p'$, and repeat until convergence.

Table 3 Comparisons of fatigue load limit calculations and catalogue values of three bearing companies							
Case	Bearing Designation	Critical ring	P_u [kN] Numerical, Eq. (19)	P_u [kN] ISO Eq. (20–24)	P_u [kN] Comp. 1 (*)	P_u [kN] Company 2	P_u [kN] Company 3
1	6205	Outer	0.383	0.358	-	0.41	0.335
2	7308	Inner	1.38	1.36	-	2.39	1.37
3	NU 408	Inner	11.40	11.48	-	12.7	11.6

(*) in case of Company 1 the values of fatigue load limit were not found in the company bearing catalogue.

Relationship bearing load—contact load. The relationship between the bearing load (radial) E_r and the heaviest-loaded contact load is already given (Ref. 4); a consequence of this is Equations (10). Now, for most of the radial bearings the heaviest-loaded contact is often in the inner ring, but a check is always convenient to do. Therefore, from Equation (127) (Ref. 4):

$$F_r = J_r Q_{max} Z \cos \alpha \quad (18)$$

As described above, $J_r = 0.2288$ for a single-row ball bearing and $J_r = 0.2453$ for a single-row roller bearing, thus yields — For ball bearings.

$$F_r = 0.2288 Q_{max} Z_i \cos \alpha \quad (19a)$$

For roller bearings.

$$F_r = 0.2453 Q_{max} Z_i \cos \alpha \quad (19b)$$

ISO methodology for the calculation of P_u .

The ISO standard (Ref. 1) includes the complete equations for the calculation of P_u for ball bearings that are based on Equation (19a),

$$P_u = 0.2288 Q_u Z_i \cos \alpha \quad (20)$$

Where

$$Q_u = \min(Q_{uv}, Q_{ue}) \quad (21)$$

Ball bearings. Notice that the inner ring and Q_{ui} outer ring Q_{ue} contact loads for a maximum pressure of σ_{Htu} in the heaviest-loaded rolling element; they can also be calculated from Equations (8) and (9). However, here the equations given in (Ref. 1) are used.

$$Q_{ui} = \left(\frac{2\pi\sigma_{Htu}}{3} \right)^3 \frac{1}{M_i} \left(\frac{6}{\pi E'} \right)^2 \left(\frac{E(k_i)}{\Sigma\rho_i} \right)^2 \quad (22a)$$

$$Q_{ue} = \left(\frac{2\pi\sigma_{Htu}}{3} \right)^3 \frac{1}{M_e} \left(\frac{6}{\pi E'} \right)^2 \left(\frac{E(k_e)}{\Sigma\rho_e} \right)^2 \quad (22b)$$

Where $\Sigma\rho$ is the sum of curvatures (reciprocal or radii); E is the complete elliptical integral of the second kind, $k = \sqrt{1-M^2}$ is the elliptical integral modulus; and M is the complementary modulus, $M = a/b$. Notice that Equations (22) require all the stress values ($\sigma_{Htu} E'$) in N/mm^2 and all distance values in mm .

Roller bearings. For roller bearings, ISO recommends using a full numerical contact solver and does not provide an equation. However, based on Hertzian theory for line contact, an approximation can be derived for Q_{ui} and Q_{ue}

$$Q_{ui} = \frac{2\pi l_a (\sigma_{Htu})^2}{E' \Sigma\rho_i} \quad (23a)$$

$$Q_{ue} = \frac{2\pi l_a (\sigma_{Htu})^2}{E' \Sigma\rho_e} \quad (23b)$$

Finally,

$$P_u = 0.2453 Q_u Z_i \cos \alpha \quad (24)$$

Where Q_u is calculated with the use of Equations (21), (23a) and (23b). Notice that Equation (23) requires all the stress values ($\sigma_{Htu} E'$) in N/mm^2 and all distance values in mm .

Calculation examples of fatigue load limit. The same bearing examples given in Table 1 are used for the fatigue load limit calculation. Also, the catalogue values published by the same three different bearing manufacturers will be investigated. The methodology described in the previous sections is applied and the results are summarized in Table 3.

In the calculation for cases 1 and 2, the radii of the inner ring grooves are also required. This information is not available for the three selected bearing manufacturers, but based

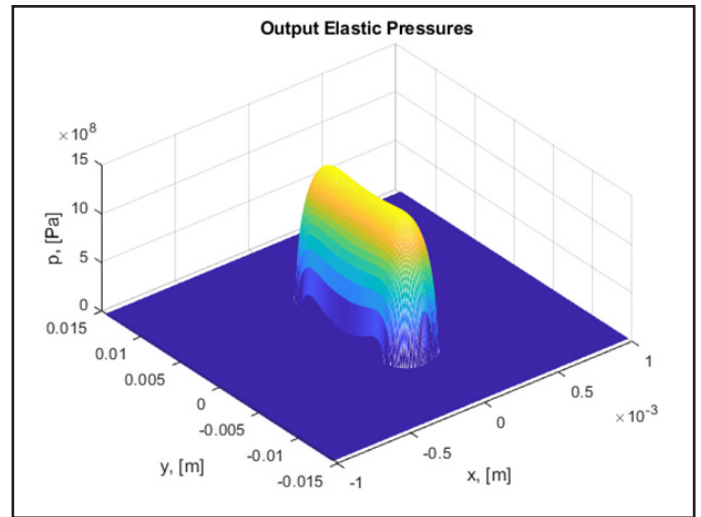

(a). Heaviest rolling element contact pressure

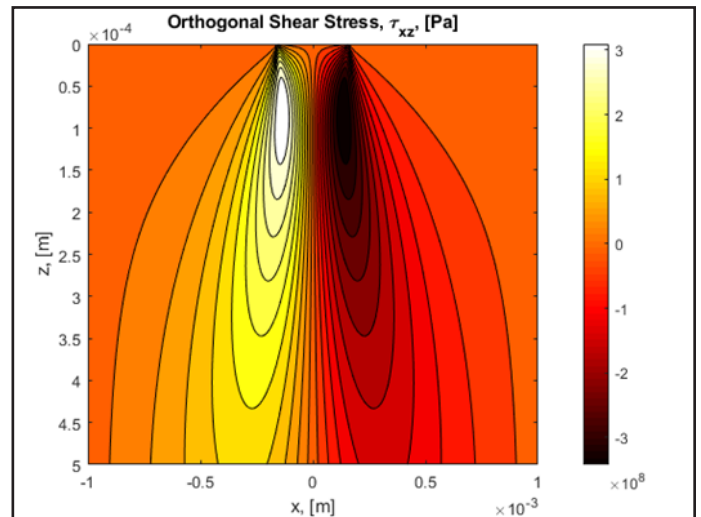

(b). Orthogonal shear stresses

Figure 1 Contact pressure and orthogonal shear stress τ_{xz} for the heaviest loaded contact in the inner ring for the case 3 of Table 3.

Table 4 Comparisons of static load rating calculations and catalogue values of three bearing companies

Case	Bearing Designation	C ₀ [kN] Numerical, Eq. (19)	C ₀ [kN] ISO Eq. (20, 23)	C ₀ [kN] Company 1	C ₀ [kN] Company 2	C ₀ [kN] Company 3
1	6205	8.74	7.80	7.85	7.8	7.8
2	7308	32.36	33.18	33.0	34.5	32.5
3	NU 408	90.02	90.5	89.0	95.0	90.0

on ISO geometry values (Ref. 1), approximations can be used. Thus, for cases 1 and 2, $r_i \approx 0.52D_w$ and $r_e \approx 0.53D_w$.

For case 3, a straight roller profile with rounded chamfers is used in the calculation. For illustration purposes, the calculated results of case 3 (NU 408) are depicted (Fig. 1), where the contact pressure and sub-surface orthogonal shear stress τ_{xz} are shown.

Notice that, for all the cases of Table 3, a somehow smaller limiting stress than the one given in ISO has been applied. The reason is that this stress has variability—as explained (Ref. 9). Initially, it is based on a value, $\max(\tau_{xz}) = 360 \pm 4\% \text{ MPa}$, that corresponds to a maximum contact pressure of $1500 \pm 4\% \text{ MPa}$ thus in order to be conservative in the calculation a minimum value of $\max(\tau_{xz}) = 346 \text{ MPa}$ was selected, which corresponds to a maximum contact pressure of $1,442 \text{ MPa}$. The maximum stress in Fig. 1(b) is $\max(\tau_{xz}) = 349 \pm 4\% \text{ MPa}$, very close to 346 MPa .

Another observation from the results of Table 3 is that only open information for 2 of the 3 companies was found for P_u . It can be seen that Company 3 agrees somewhat well with the numerical and ISO methodologies, while Company 2 has substantially higher values. It is true that some companies have “higher-performance” bearings (reduced manufacturing tolerances, higher geometrical precision, improved surface finish, etc.) resulting in longer fatigue life which, in a way, could be considered as an increase of the value. But this would be non-conformal with ISO, since the value of the fatigue limit in ISO has been fixed and it is standardized to a mean of value of $\tau_{xz} = 1500 \text{ MPa}$ with $\pm 4\%$.

Therefore the only feasible way to affect the fatigue performance of the bearing in a way that is consistent with the ISO requirements would be to use Equation (2) and modify the penalty factor η_a by redefining the value of the macro-scale stress factor. In this way it is clear that the fatigue limit of the bearing material is not affected by technological manufacturing improvements, and the progress in the bearing quality is indeed represented by rating factors that are designed expressly for that end. Load rating practices that simply increase the value of the fatigue load limit of the bearing P_u to reflect technological improvements are non-conformal with ISO 281. This may generate misperception in bearing users and distrust in the applied rating system as a whole. Thus these practices should be avoided.

Static Load Rating

The static load rating C_0 is a performance parameter that does not enter directly in the rating life estimation of the bearing. However, it is a parameter related to maximum load bearing safety and its performance under low cycle fatigue. It is used in the estimation of the safety factor of the bearing regarding extreme loading conditions. Thus, it is important to discuss it here.

ISO:76:2006 (Ref.12) defines the static load rating as: “Experience shows that a total permanent deformation of

0.0001 of the rolling element diameter, at the center of the most heavily loaded rolling element/raceway contact, can be tolerated in most bearing applications without the subsequent bearing operation being impaired. The basic static load rating is, therefore, given a magnitude such that, approximately, this deformation occurs when the static equivalent load is equal to the load rating.”

And it goes on as indicated by the different nominal maximum contact pressures that can be used in practice for a quick determination of this rating:

“Tests in different countries indicate that a load of the magnitude in question can be considered to correspond to a calculated contact stress of

- 4,600 MPa for self-aligning ball bearings
 - 4,200 MPa for all other ball bearings
 - 4,000 MPa for all roller bearings
- at the center of the most heavily loaded rolling element/raceway contact. The equations and factors for the calculation of the basic static load ratings are based on these contact stresses.”

Therefore, the numerical calculation of the static load rating follows a very similar process as the fatigue load limit, but using different stress levels when it comes to individual bearings. For standard static rating values, ISO 76 (Ref. 12) provides all the equations needed for the calculation of the static load rating—as shown below:

For ball bearings.

$$C_0 = f_0 D_a^2 Z \cos \alpha \tag{24a}$$

With the f_0 constants given in Table 1 of the ISO document (Ref. 12).

For roller bearings.

$$C_0 = 44 \left(1 - \frac{D_a \cos \alpha}{d_m} \right) I_a D_u Z \cos \alpha \tag{24b}$$

In the above equations, all units of length are in mm and calculated loads C_0 are in N .

Calculation examples of static load rating. The same examples are considered. Table 4 shows the results and comparison with values given by the three main bearing manufacturers. It can be seen that in general there is good agreement between the calculated values and reported values from different manufacturers. The numerical method shows also minor deviations. Taking the ISO values as reference, the maximum deviation is of 5% observed for Company 2; but this is to be expected since the exact details of the bearing internal geometry are unknown and approximated here. This can introduce the observed variation.

For practicing engineers, the comparison of C_0 values can be a good reference point when bearings of very similar internal geometry and material hardness are compared. It can be seen that there is more consistency among different bearing

manufacturers with this load performance parameter than with any of the others.

Data Back-Up via Testing

Experienced rolling bearing companies should always be backing the values of rated performance of catalogue products using endurance testing. Of course, testing also has limitations, e.g.: (i) only certain bearing sizes make economic sense to test; (ii) tests are performed, mostly under stationary loading conditions; (iii) and tests can target only rolling contact fatigue — which is one of the main failure modes of rolling bearings. Nevertheless, despite these limitations, fatigue testing can provide strong statistical validation of the dynamic load ratings that are applied to bearings, particularly in the case where this methodology is systematically applied through the years so that data-pooling and trend analysis can be applied, providing an overview of the performance of the products over the years and across different types and sizes of the products.

Endurance testing is an important instrument to reduce the risk related to the improper application of standardized dynamic load ratings to lower-quality bearings. Such bearings are, in principle, outside the scope of the ISO 281 standard. However, given the imprecise formulation of the scope of the standard, this can be difficult to prove. The risk of an improper use of the standard is high — especially in the case of bearing products originated from new manufacturing companies that are not equipped with testing facilities for the verification of the dynamic rating of their products. Thus for new manufacturers, the application of ISO 281 offers a simple and ready-to-use solution for the performance rating of their products.

Many of these companies present their products as “fully ISO compliant” to impart a positive perception. While in reality, this description is not qualified to represent either the actual quality or actual dynamic performance.

In contrast, well-established bearing companies with a long tradition in bearing fatigue life ratings routinely perform endurance testing of their products to assess and verify the C values quoted in their catalogues. In the following, typical endurance testing methods used for the assessment of C dynamic load rating of rolling bearings are briefly reviewed. The fatigue limit (σ_{flu}) cannot be assessed via endurance testing due to the extremely long testing times it would require. However, other techniques can be applied — like ultrasound testing of steel (Ref. 2). For the static dynamic load rating C_0 verification, static load testing in bearings and brinelling measurement can be applied.

Verifying the dynamic load rating C by testing. Bearing companies with experienced engineering generally apply best-in-class endurance testing practices (Refs. 13–14). Endurance test results are then evaluated using rigorous Weibull statistical analysis (Refs. 15–16). Such test methods are briefly summarized hereafter.

A common endurance-testing practice to verify the dynamic load rating C of a bearing is to conduct at least two full endurance tests on a randomly selected population of bearing samples. The tests are usually performed under good lubrication conditions ($\kappa \geq 2$). This is done to remove any significant influence of the *lubrication* on the rolling contact

fatigue life of the bearing that is measured.

The load and speed of the test are chosen to minimize the running time of the test. Typically the suspension time of test is set to be $>L_{50}$ of the expected fatigue life under the given test condition. This ensures that a sufficient sample size of bearings failures are generated (≥ 6) during the test — thus allowing for good precision of the Weibull statistics results.

In practice, this often implies running a bearing sample population of about 20 or 30 bearings per each test under load conditions of $1 \leq C/P \leq 3$, depending on bearing type and size. The test in this way will provide a good metrics of the life of the bearings and related confidence intervals of the results. This is particularly the case for Figure 2, i.e. — that several endurance test results are merged into a single test data pool.

Figure 2 shows a typical example of Weibull plots from comparative endurance tests of two bearing populations (A) and (B). The results of the test show a clear difference in per-

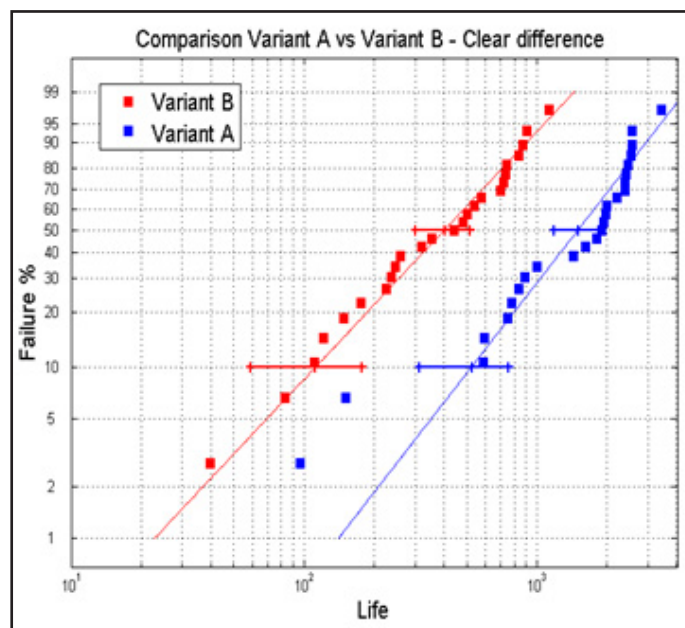

Figure 2 Weibull plots of the endurance tests failures of two different bearing populations.

formance of the two bearing populations. This can be seen from the confidence intervals of L_{10} and L_{50} the life of the two test series that are clearly well apart from each other.

Reverse calculation of the bearing life, Equation (1), is used to estimate the value that will give a calculated life below the confidence interval of the measured L_{10} life. This is needed to ensure the strong experimental significance $> 95\%$ of the dynamic load rating that is verified, as schematically illustrated (Fig. 3).

This set-up of the model ensures that all calculations will result in predicted lives within the high percentile region of the experimental significance of the measured L_{10} life. On the contrary, if a model is set to coincide exactly on the measured $L_{10(50\%)}$ this would imply a weak experimental significance. In other words there is a low probability that the endurance tests are able to verify the results of the calculated life. Indeed, in such a case about 50% of the times the calculated life could find itself at the right-hand side of the endurance tests' Weibull line, thus overpredicting the fatigue life of the bearing.

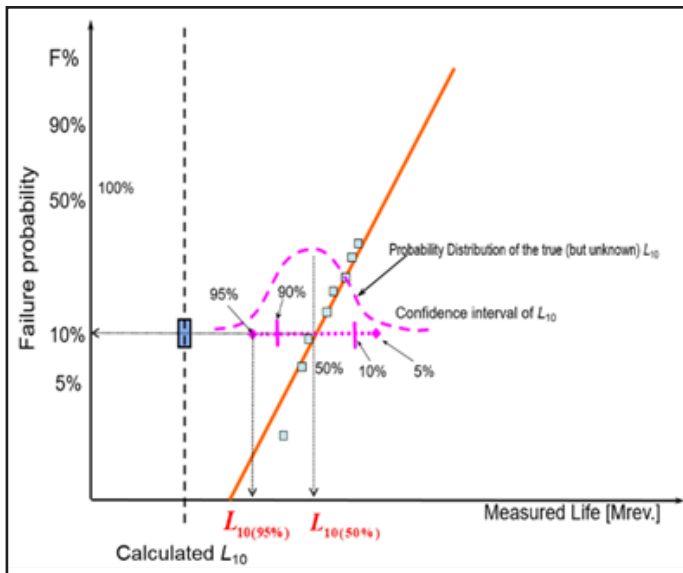

Figure 3 Simplified illustration of a Weibull plot showing the measured L_{10} life at different percentiles of experimental significance. The calculated life using Equation 1 is also shown at the left of the 95% percentile of experimental significance of the measured life, thus ensuring a high degree of experimental verification of the fatigue life that is calculated.

As discussed earlier, the dynamic load rating C can be obtained from ISO 281 using the bearing's overall geometry (Ref. 7), and the constant factor b_m related to the technology and quality of manufacturing. In some cases, bearing companies use this factor to reflect some recently introduced technological improvements in manufacturing, e.g. — high-strength steel and heat treatment — which may surpass the ISO standard values. This is possible and should be acceptable when the new values are verified by proper endurance testing practices, as discussed above. Unfortunately, rolling bearing endurance life testing for the dynamic load ratings of rolling bearings is not part of the ISO standard. This might create some uncertainty in the procedures that are applied and in the dynamic load rating in use. This is also why the authors strongly favor the introduction of endurance testing standards for rolling bearings in the ISO.

Discussion

The process of calculating performance rating parameters (C, P_w, C_0) in rolling bearings has been systematically reviewed in this paper. It can be seen that, in general, advanced numerical schemes fit well with the simplified ISO equations. In the comparison carried out with values reported by three well-established bearing manufacturers, it is found that the performance parameters that are affected by the largest variability are, C and P_w . To practicing engineers, this suggests C_0 as a good reference parameter to compare the real internal geometry of bearings originated from different manufacturers. About this, particularly significant is the case of P_w , since this parameter is derived from the same numerical scheme used to calculate C_0 (the only difference is the contact stress level that is applied); thus similar behaviors should be expected.

For example, if two companies have the same reported C_0 , they should also have the same and similar C (within a small variation of the application of the b_m factor). Where this is

not the case, engineers are entitled to question the validity of the values that are reported and to request clarification. In general, well-established bearing companies regularly perform endurance testing to verify the load ratings published in their catalogues. Typical endurance testing practices for the verification of the dynamic load ratings of rolling bearings are briefly reviewed in this paper. A sufficient number of bearings, i.e. — population sample — need to be endurance-tested to gather the necessary statistical data of the fatigue performance of the bearing. Equation (1) is then applied to calculate the L_{10} life, corresponding to a given C rating. For a positive verification of the dynamic load rating, the calculated life L_{10} should be located well on the left-hand side of the Weibull line to achieve a high degree of experimental significance. Therefore, it must always be: $L_{10, \text{calculated}} \leq L_{10(95\%)}$, (Fig. 3). In addition to this type of experimental verification, practicing engineers can also check the quoted C value (Ref. 7) by simply manually measuring the bearing geometry and quantities used in Equations (12) and (13). After adjustment of the results using the corresponding ISO values for b_m , the calculated C value should be a good approximation of the bearing manufacturer's reported value.

Due to the continuous high demand for rolling bearings, many new bearing manufacturers are entering the market today. It is unlikely that these new players have adequate endurance testing capabilities for the verification of the dynamic load ratings that are quoted in their catalogue. Yet, the new manufacturers take direct advantage of the ISO 281 (Ref. 4) rating formulae that are valid only for: “*commonly used, high-quality, hardened bearing steel in accordance with good manufacturing practices, the value of which varies with the bearing type and design.*” Therefore the practicing engineer should question the validity of the dynamic load rating, particularly in the case of new bearing manufacturers that do not apply endurance testing methods for the verification of the load ratings of their products.

Finally, it is well known that in modern applications subsurface failures are a rare occurrence. This is due to the good knowledge and experience accumulated over the years — certainly reflected in the work shown in References 3–5. All three of the discussed rating parameters refer to Hertzian stresses or subsurface condition of the bearing. When they do occur, most of the time an explanation related to overloading or material defects can be found (Ref. 17). However, most issues that rolling bearings face today are fatigue damage occurring at the very surface of the bearing raceway, where tribological fatigue mechanisms are playing a major role. Models to describe these issues involve mixed elastohydrodynamic lubrication (EHL) of the rolling contact (Refs. 18–21), and not just the Hertzian stress and general contact mechanics. The rolling contact fatigue of the raceway surface implies the combined effect of EHL lubrication, roughness, friction and wear. This is why the authors have developed a novel approach to bearing fatigue life prediction that separates the surface from the sub-surface survival of the bearing rolling contact (Refs. 22–23). Therefore, the reader should wonder if it is not the time to introduce more suitable dynamic load rating factors for rolling bearings, as has been suggested in the case of gears (Ref. 24).

Conclusions

Three main performance parameters used in rolling bearing application engineering have been methodically reviewed: the dynamic load rating C , the fatigue load limit P_u and the static load rating C_0 . The ISO equations for the calculation of these three parameters were also discussed, along with more general numerical calculation schemes. Calculated values using both procedures were compared. Published values of the corresponding performance parameters quoted from three well-established bearing companies were provided for reference, and as examples of present day rating practices. In the discussion, simple guidelines have been outlined to distinguish between likely and unlikely “truthful” and consistent values. Finally, from this analysis the following conclusions can be outlined:

1. Numerical contact mechanics schemes and analytical ISO equations are in general agreement for all three parameters, C, P_u, C_0 .
2. Reported performance parameters of three well-established bearing manufacturers show that, (unlike the value of P_u) the static load rating C_0 represents the most consistent factor to compare the internal geometry and design variation among bearing manufacturers.
3. Good work practices of bearing manufacturers must include systematic verification of their catalogue load rating, using well-established endurance testing methods. This is true also for the application of the ISO 281 load ratings or for the validation of rating change resulting from new technological developments.
4. The lack of a quantitative definition of the bearing quality and quality practices in rolling bearings by ISO 281 and the undifferentiated application of this standard by newcomer bearing manufacturers with no testing facilities or practices to verify their ratings, call for the need of an ISO standard to describe best endurance testing practices and statistical data analysis for the rating of rolling bearings. **PTE**

Acknowledgment. The authors want to thank Mr. **Bernie van Leeuwen**, SKF Research and Technology Development, for his kind permission to publish this paper.

For more information.

Questions or comments regarding this paper?
Contact Antonio Gabelli, Ph.D. at antonio.gabelli@skf.com.

References

5. International Standard ISO 281, Rolling Bearings – Dynamic Load Ratings and Rating Life, 2nd Ed.; 2007.
6. Gabelli, A., A. Doyer and G.E. Morales-Espejel. “The Modified Life Rating of Rolling Bearings – A Criterion for Gearbox Design and Reliability Optimization,” AGMA Technical Paper 14FTM16, pp. 1–16, 2016.
7. Ioannides, E., G. Bergling and A. Gabelli. “An Analytical Formulation for the Life of Rolling Bearings,” Acta Polytechnica Scandinavica, Mechanical Engineering Series No. 137, The Finnish Academy of Technology, 1999.
8. Lundberg, G. and A. Palmgren. “Dynamic Capacity of Rolling Bearings,” Acta Polytechnica Mechanical Engineering Series, Royal Swedish Academy of Engineering Sciences, vol. 1, No. 3, 7, pp. 1–50, 1947.
9. Lundberg, G. and A. Palmgren. “Dynamic Capacity of Roller Bearings,” Acta Polytechnica Mechanical Engineering Series, Royal Swedish Academy of Engineering Sciences, vol. 2, No. 4, 96, pp. 1–33, 1952.
10. ISO Technical Report ISO/TR 1281-1. Rolling Bearings – Explanatory Notes on ISO 281 – Part 1: Basic Dynamic Load Rating and Basic Rating Life, 2008.
11. Parker, N., “Desktop Engineering – How to Calculate Dynamic and Static Load Ratings,” *Power Transmission Engineering* #2 (February), pp. 40–43, 2015.
12. Ioannides, E. and T.A. Harris. “New Fatigue Life Model for Rolling Bearings,” *Trans. ASME, J. Trib.*, 107, pp. 367–378, 1985.
13. Gabelli, A., J. Lai, T. Lund, K. Rydén, I. Strandell and G.E. Morales-Espejel. “The Fatigue Limit of Bearing Steels – Part II: Characterization for Life Ratings Standards,” *Int. J. of Fatigue*, 38, pp. 169–180, 2012.
14. ISO Technical Report ISO/TR 1281-2. Rolling Bearings – Explanatory Notes on ISO 281 – Part 2: Modified Rating Life Calculation, Based on a Systems Approach to Fatigue Stresses, 2008.
15. Morales-Espejel, G.E., A.W. Wemekamp and A. Félix-Quiñonez. “Micro-Geometry Effects on the Sliding Friction Transition in Elastohydrodynamic Lubrication,” *Proc of IMechE, Part J, Journal of Eng. Tribology*, 224, pp. 621–637, 2010.
16. International Standard ISO 76. Rolling Bearings – Static Load Ratings, 3rd ed.; 2006.
17. Andersson, T. “Endurance testing in Theory,” *Ball Bearing Journal* 217, pp. 14–23, 1983.
18. Leenders, P. “Endurance Testing in Practice,” *Ball Bearing Journal* 217, pp. 24–31, 1983.
19. McCool, J. I. “Evaluating Weibull Endurance Data by the Method of Maximum Likelihood,” *ASLE Transactions*, 13:3, pp. 189–202, 1970.
20. McCool J.I. and R. Valori. “Evaluating the Validity of Rolling Contact Fatigue Test Results,” *Tribology Transactions*, 52:2, pp. 223–230, 2009.
21. Manieri F., K. Stadler, G.E. Morales-Espejel and A. Kadircic. “The Origins of White Etching Cracks and their Significance to Rolling Bearing Failures,” *International Journal of Fatigue*, 120, pp. 107–133, 2019.
22. Morales-Espejel G.E., A. Gabelli and E. Ioannides. “Micro-Geometry Lubrication and Life Ratings in Rolling Bearings,” *Proc. of IMechE, Part C, Journal of Mechanical Eng. Science*, vol. 224, pp. 2610–2626, 2010.
23. Morales-Espejel, G.E. and V. Brizmer. “Micropitting Modelling in Rolling–Sliding Contacts: Application to Rolling Bearings,” *Trib. Trans.*, 54, pp. 625–643, 2011.
24. Morales-Espejel, G.E., V. Brizmer and E. Piras. “Roughness Evolution in Mixed Lubrication Condition due to Mild Wear,” *Proc. IMechE, Part J, J. of Mech. Eng.*, 229 (11), pp. 1330–1346, 2015.
25. Brizmer, V., H.R. Pasaribu and G.E. Morales-Espejel. “Micropitting Performance of Oil Additives in Lubricated Rolling Contacts,” *Trib. Trans.*, 56(5), pp. 739–748, 2013.
26. Morales-Espejel, G.E., A. Gabelli and A.J.C. de Vries. “A Model for Rolling Bearing Life with Surface and Subsurface Survival—Tribological Effects,” *Trib. Trans.*, 58(5), pp. 894–906, 2015.
27. Gabelli, A. and G.E. Morales-Espejel. “A Model for Hybrid Bearing Life with Surface and Subsurface Survival,” *Wear*, 422–423, pp. 223–234, 2019.
28. Morales-Espejel, G.E. and A. Gabelli. “A Model for Gear Life with Surface and Subsurface Survival: Tribological Effects,” *Wear*, 404–405, pp. 133–142, 2018.

For Related Articles Search

bearings

at www.powertransmission.com

Appendix A — Detailed Parameter Description, Dynamic Load Rating

The use of Equations 4-7 requires the definition of the following quantities:

$$\Sigma\rho = \frac{1}{R_{1x}} + \frac{1}{R_{1y}} + \frac{1}{R_{2x}} + \frac{1}{R_{2y}} \quad (A1)$$

In equation (A1) the radii are negative for concave curvatures.

The amplitude of the normalized orthogonal shear stress τ_{xz}/p_0 is given by:

$$T = \frac{\sqrt{2t-1}}{2t(t+1)} \quad (A2)$$

Where t can be obtained by solving the following equation:

$$\frac{a}{b} = \sqrt{(t^2-1)(2t-1)} \quad (A3)$$

The position of the maximum shear stress is determined by,

$$z_0 = \varepsilon a \quad (A4)$$

$$\varepsilon = \frac{1}{(t+1)\sqrt{2t-1}} \quad (A5)$$

Finally, from Equation (101) of (Ref. 4):

$$v = \sqrt[3]{2\pi(a/b)E(k)} \quad (A6)$$

$$\mu = \frac{v}{\left(\frac{a}{b}\right)} \quad (A7)$$

Now, the exponents are defined as follows (Ref. 4):

$$c = \frac{31}{3}, \quad h = \frac{7}{3}, \quad w = pe$$

For point contact (ball bearing): $e = \frac{10}{9}, p = \frac{c-h+2}{3e}$

For line contact (roller bearings): $e = \frac{9}{8}, p = \frac{c-h+1}{2e}$,

exponent e corrected from 3/2 to 9/8 (Ref. 5).



Antonio Gabelli, Ph.D. is senior scientist working at SKF on tribology and rolling contact fatigue life of rolling bearings. He joined the Engineering and Research Center of SKF in Netherlands in 1981, since then he published many research papers on fatigue and lubrication of rolling bearings. He was one of the key contributors to the new bearing life theory, developed by SKF in the 90's He is also author of several patents on rolling bearings. He holds a mechanical engineering degree from the University of Padua (Italy) and a Ph.D. degree in from Chalmers Technical University of Gothenburg (Sweden).



Guillermo Enrique Morales-Espejel, Ph.D., H d R, prof., employed by SKF in the Research and Technology Development, Université de Lyon, LaMCoS, INSA-Lyon. He is Principal Scientist SKF Research and Technology Development, The Netherlands, Chair Professor at LaMCoS, INSA de Lyon, France. He was recently appointed Visiting Professor at Imperial College London. He holds a Ph.D. in Tribology from the University of Cambridge, U.K., and is holder of "Habilitation à Diriger des Recherches (INSA-Lyon)," 10 years lecturer in university and 20 years of experience in rolling bearings. He is the author of more than 70 scientific papers and several book chapters and is Associated Editor of Tribology Transactions and IMechE Part J. His scientific interests are: Modelling of Bearing life, friction, lubrication and surface life.



PRECISE. ROBUST. AVAILABLE.

CD® Couplings

- Zero-Backlash & High Torsional Stiffness
- Engineered Performance for Reliable 24/7 Operation
- Servo-Rated for Reversing, Positioning & Precision
- Single-Flex, Double-Flex, Floating-Shaft Solutions
- Standard Models / Fully **Customizable**
- Engineering Assistance / **Fast** Delivery



www.zero-max.com 800.533.1731

ZERO-MAX®

Fenner Precision Polymers

EXPANDS PORTFOLIO WITH MAV ACQUISITION

MATTHEW JASTER, SENIOR EDITOR

Fenner Precision Polymers, a Michelin Group Company, recently announced the acquisition of MAV S.p.A., an Italian company, located in Altopiano della Vigolana in Northern Italy.

Established in 1989, the company is a leading European supplier of keyless-locking devices (KLD), shrink discs, rigid couplings, and other metal products. The acquisition offers an opportunity for growth, market share gains and improvements to Fenner Precision Polymers' global supply chain by adding a second inventory and supply base.

"We believe the acquisition will help us position keyless technology as a preferred solution in hub to shaft applications," said Brian Slingluff, vice president, global sales and marketing at Fenner Precision Polymers. "We've had a working relationship with MAV that helped establish the keyless locking devices market here in North America, so the foundation was already in place."

"Under ideal circumstances all parties benefit during an acquisition, and that is certainly the case here," said Jack Krecek, divisional managing director, Fenner Precision Polymers. "All customers, including those in underserved and emerging markets, will benefit from our combined technical expertise, speed to market and turnaround times. MAV will continue operating under its esteemed brand, while also gaining access to a global sales force with considerable client relationships."

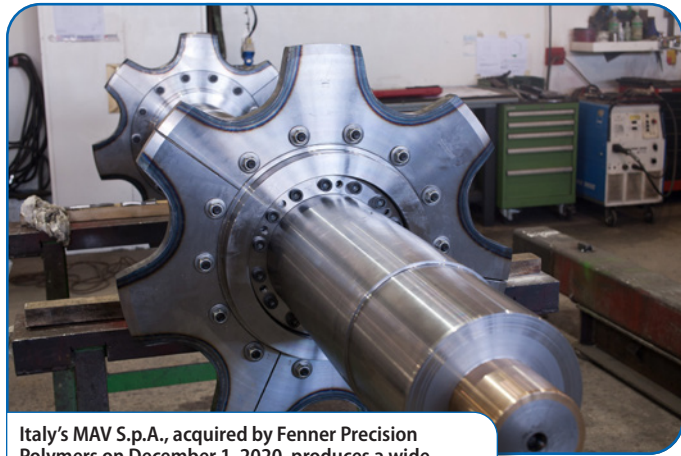

Italy's MAV S.p.A., acquired by Fenner Precision Polymers on December 1, 2020, produces a wide variety of engineered solutions like the keyless locking device shown here, used in apron feeder applications.

While many organizations have scaled back during the pandemic, the company saw an opportunity to increase its global reach and expand its in-person sales team. Krecek believes the secret to success during challenging times is simply "not to oversteer one way or another."

"I think it's a credit to our entire organization that we've managed to stay on task and understand the markets we serve. Areas like aerospace, oil and gas, and mining etc. are going through tough times, but we feel we have the tools and technologies to serve these markets as they start to come back," Krecek said.

MAV's Elisa Perazzoli facilitated the virtual employee and press presentations by MAV's former CEO, Sandro Zamboni and Fenner Precision Polymers' Divisional Managing Director, Jack Krecek.



"We're already seeing signs of improvement in areas like distribution centers and medical devices," Slingluff added. "We believe these markets will get stronger in the coming years."

Some credit for the company's success goes to a push in recent years for smart manufacturing initiatives.

"We are about a year into our IoT journey in Pennsylvania with purposeful investment in data capture that brings value to our customer. The first implementation was the integration of our tooling data with our belt slitting operations, eliminating human error, and significantly reducing scrap across several processes," Slingluff said.

Another significant investment is in coating technology for textiles products.

"This technology allows us to 'dial in' our thickness and provide traceability to meet the customer's specification for high performing applications in the aerospace industry," he added.

Looking ahead to 2021, Fenner Precision Polymers plans on extending Industry 4.0 into its extruded belting operations to utilize machine data for control and decision-making in 'real time' for product and operation optimization.

For now, however, the focus is getting MAV up to speed on the global benefits Fenner Precision Polymers can provide.

"The expression 'small is beautiful' has long defined Italian ingenuity," said Sandro Zamboni, CEO, MAV. "Though a small company, when viewed through the eyes of globalization, MAV's expertise looms large. We've successfully penetrated distant markets, strengthened relationships with customers and earned their trust and respect. However, we've now grown too big to remain small. This venture welcomes MAV to a larger multinational organization and better positions it to serve all markets. Joining with Fenner Precision Polymers offers a tremendous benefit to our customers as well, through our combined technical acumen, the resulting innovations in engineered solutions and the anticipated benefits from economies of scale."

The Fenner Drives B-LOC keyless bushing brand provides a high capacity, zero-backlash shaft-to-hub connection by using the simple wedge principle. An axial force is

applied by series of annular screws to engage circular steel rings and mating tapers. The resulting wedge action creates a radial force on the tapered rings, one of which contracts to squeeze the shaft while the other expands and presses into the component bore. Learn more at www.fennerdrives.com/keyless-locking-devices/.

Keyless locking devices are very popular in Europe, according to Slingluff, but not as widely used currently here in the states. Drive and system components with old-fashioned keyways and bushings are susceptible to backlash, leading to rounded out keyways, fatigue failures or fretting corrosion. Learn more at www.mav.it/en/products.html.

“Our experience with this technology as well as the technical design expertise at MAV puts us in a great position to grow our business and become a global market leader,” Slingluff said. “We’re excited to expand our technological knowhow with MAV and strengthen our product offerings.”

www.fennerppd.com
www.mav.it/en

PTDA

ANNOUNCES RECENT AWARD WINNERS

Wendy B. McDonald was one of the power transmission/motion control industry’s true pioneers. To honor her memory, the PTDA Foundation established the Wendy B. McDonald Award in 2014. The award is given to a woman who has established herself as a critical contributor to her company’s success and has affected positive change within the power transmission/motion control industry. This year’s recipient of the Wendy B. McDonald Award is **C.C. Vest** of Midpoint Bearing.

Vest began her bearing and power transmission career in 1979 at Bearings & Drives. Hired as an office clerk, she gained favor with the branch manager by conducting any and all tasks required to advance her understanding of her role in the industry. It was a short time before she was promoted to assistant manager followed by a new job in sales for a bearing manufacturer/rebuilder company.

In 1985, Vest became the co-founder of a new bearing distribution company called Midpoint Bearing. Vest was instrumental in creating a business strategy in which the company focused on supplying bearings to the electric motor repair industry. Additionally, Midpoint Bearing found success with a local steel mill. Vest oversaw the account with determination, making Midpoint Bearing a local company to reckon with and respect.

In her career, Vest navigated the power transmission industry with a never-give attitude and determination that helped blaze a trail leading to the acceptance of women salespeople in the bearing industry.



In an interview with PTDA Foundation Program Director Mary Jawgiel, Vest offered the following advice for women going into the field, “Do the best you can, be true to your values and remember integrity is everything.”

The award was presented to Vest during the PTDA Virtual Industry Summit.

The PTDA has also named **Bill Childers** the 29th recipient of its Warren Pike Award for lifetime achievement in the power transmission/motion control (PT/MC) industry.

Childers received the award, named for PTDA’s co-founder and first president, during the PTDA Virtual Industry Summit. The award was established in 1984 to honor individuals who have demonstrated outstanding, continuous, long-term support of PTDA and the PT/MC industry and is only presented when an individual’s achievements merit this prestigious recognition. Warren Pike Award recipients are selected by the PTDA board of directors.

He spent the first 25 years of his career as vice president of sales for Emerson Power Transmission. He then moved on to other roles including president of NSK Canada in 2002 and president of North American sales for Rexnord in 2008. In 2015, Childers joined Affiliated Distributors where he served as vice president and managing director, overseeing the launch of AD’s power transmission division.

During his career, he also devoted his time volunteering for various PTDA committees including serving as Manufacturer Council Chair in 2006 and PTDA Foundation president in 2010. He also served on the PTDA Board of Directors in 2013.

He thanked the board for the award and members who helped him throughout his career. Childers commented, “Getting involved with PTDA was probably the best decision I made in my 47 years in the PT business. It’s all about relationships. You can firm those up while interacting at PTDA events and that translates to your business relationships.”

ptda.org

ABB

NAMES COSTA PRESIDENT OF MECHANICAL POWER TRANSMISSION DIVISION

ABB recently named company veteran **Roger Costa** as president of its global Mechanical Power Transmission Division, also known as the Dodge business.

“ABB’s recognition as a global leader in the mechanical business stems from a strong culture that focuses on customer experience,” Costa said. “I look



forward with confidence and optimism, and I am excited to continue to lead the division and support our customers and partners.”



forward to joining a team that values that culture. Together, we will work to continue to develop and grow markets for our superior products.”

With more than 17 years of experience at ABB, Costa has held executive roles in both the US and Canada. During his tenure at ABB, Costa has gained considerable knowledge of the company’s extensive operations ranging from mechanical to motors and robotics. Costa’s unique perspective brings valuable insight to ABB’s leadership team.

Costa has a bachelor’s degree in electro-mechanical engineering from Humber College and completed an advanced university program in business management at the University of Toronto-Roman School of Management. Costa will be based in Greenville, South Carolina.

Established in the United States in 1878, the Dodge business today is considered the leading manufacturer of mounted bearing, enclosed gearing, and power transmission components in the nation.

new.abb.com/mechanical-power-transmission

MHI

HIRES VICE PRESIDENT OF SALES

Mitsubishi Heavy Industries America is pleased to announce and welcome **J. Scott Knoy** as the new vice president of sales for the Wixom, Michigan based Machine Tool Division. Knoy will be responsible for sales team leadership, driving revenue, strategic planning and marketing, as well as management responsibilities.



Knoy brings 26 years of experience in the gear machine and tooling industry. His career includes 12 years with the Gleason-Pfauter organization working as a regional sales manager in both the tooling and machinery sales groups and 14 years with GMTA (American-Wera) where he served as the vice president of sales, vice president and president.

“Scott has an impressive background in sales and executive management within the gear machine industry,” says Atsuhiko Kawaguchi, general manager of the Mitsubishi Machine Tool Division. “Scott will aggressively lead our sales team and I believe with his leadership we will overcome this unforeseen market condition.”

Knoy who resides in Howell, MI is married (Holly) and has 2 adult children (Kelsey, Karlyn). His education includes an MBA from Lawrence Technological University as well as a bachelor degree from the University of Michigan in Ann Arbor. Additionally, Knoy served as a combat engineering officer in the U.S. Army Reserve for 10 years.

He will be replacing long standing Senior Vice President Tom Kelly. Kelly began his career in the machine tool business in 1987 when he started selling Mitsubishi Machine Tools for a local dealer. Two years later, he joined Mitsubishi

International Corporation (the importer for MHI). After more than ten years of local success, he approached Mitsubishi Heavy Industries America with a proposal to eliminate the existing dealer network and take over all sales and service responsibilities for North America. Tom will be retiring at the end of December, and will move with his wife Cayce to their home in North Carolina

www.mitsubishigearcenter.com

Bearing World

PRODUCES NUMEROUS HIGHLIGHTS FOR KLINGELNBERG

This year’s Bearing World exhibition took place for the first time as a virtual event from October 19–23 2020. Virtual event organizer Forschungsvereinigung Antriebstechnik e.V. (FVA) provided a platform of exchange focusing on bearing types and all the components involved. Klingelberg presented as a sponsoring partner with a virtual exhibition concept that combined various forms of digital content and live chats with Klingelberg experts.



The event host counted more than 1,100 participants in total. Top speakers from the roller bearing and applied industry and leading research institutions presented talks on a broad range of topics. Interested attendees also had the opportunity to get to know the various companies on a virtual tour of the exhibition. The online information offering included product videos and other ways to download detailed documentation, among many other things. Throughout the five-day event, Klingelberg experts in roller bearing measurement technology—Dr. Christof Gorgels (head of precision measuring centers product line), Holger Haybach (product management, precision measuring centers), and Stefan Staab (business development)—were on hand for live chats.

“Bearing World is a fantastic platform for showcasing our expertise in the area of bearing measurement technology and our Klingelberg Done-in-One measurement solutions,” noted Staab in summarizing the event. “We are already looking forward to continuing our dialog with event attendees.”

www.klingelberg.com

SKF and Imperial College London

EXTEND R&D PARTNERSHIP

SKF, founded in 1907 and Imperial College London, involved in tribology research since 1948, are extending their R&D partnership. The SKF University Technology Centre (UTC) has been housed at Imperial College London since 2010 and has delivered research that helps bearings perform better and longer, whilst also contributing to lower energy consumption in the machines they operate in. This work will now continue until 2025.

Dr. Kenred Stadler, SKF's R&D Collaboration Manager, said: "Tight collaboration between leading academia and R&D-driven companies like SKF is key to increasing the speed of innovation in industry."



"Through our relationship with Imperial College London, which first started in the 1970s, we will drive both short-term, agile projects lasting a few months as well as longer-term Ph.D. projects," he added.

Students involved in the SKF UTC at Imperial College London have an opportunity to work with some of the industry's most unique test facilities, including a novel sapphire bearing rig that enables the in-situ observation of bearing lubrication.

Prof. Dr. Guillermo Morales, Principal Scientist at SKF, said: "The bearing industry has so many fantastic research opportunities. It's great to partner with universities like Imperial College London to make sure some of the brightest minds out there apply their skills to the field of tribology. Collectively, we will be able to think outside the box to make even greater advancements."

"By better understanding the theory behind tribology-related failure mechanisms, we can design better and more efficient bearings. Working in close partnership with Imperial College London, our R&D teams in Houten, Netherlands, can greatly increase the speed at which this work can be conducted," Morales said.

www.skf.com

MISSING A PIECE?

We've got you covered! Go to powertransmission.com to see what you missed in last month's issue, plus another thirteen years of back issues, industry and product news, and more!

In last month's issue:

- Condition Monitoring for Gear Drives and Gearmotors
- Motors for Cooling Towers
- Dynamic Behavior of Planetary Gears
- Hybrid Step Motors

...and more!
Power Transmission Engineering

CALL FOR PAPERS!

Are you sitting on an idea for a technical paper but wondering where to present it? Do you have one already written, sitting on your desk, gathering machine dust?

How about *Power Transmission Engineering*? We are always looking for gearing- and power transmission component-relevant technical papers for publication in the magazine and in its digital version. Having your work appear in *Power Transmission Engineering* guarantees you an audience of the most experienced and discriminating industry players. You say your work has not been peer-reviewed? Not a problem, as we are lucky—and thankful—to have on-hand some of the most experienced and brilliant minds in the industry—our technical editors. So if your work “passes muster” and is published, you’ll know you were reviewed by the best—and most demanding.

Chances are you’ll be creating the paper under the auspices of the company for whom you work or own, or for one of the various industry-relevant associations. That means they as well will bask in the reflected glory that accrues with publication in *Power Transmission Engineering*.

For publication guidelines and more information, please contact Jack McGuinn at jmcguinn@powertransmission.com.

AGMA

Pages 32-33
MotionPowerExpo.com

Andantex

Page 11
andantex.com

B&R Machine and Gear

Page 68
www.brgea.com

BDH Belts

Page 68
www.bdhbelts.com

Beyta Gear Service

Page 2
www.beytagear.com

Bonfiglioli USA

Pages 27, 53

Brother Gearmotors

Inside Front Cover
BrotherGearmotors.com

Cincinnati Gearing Systems

Page 16
www.cincinnatigearingsystems.com

Circle Gear

Page 14
www.circlegear.com

Designatronics

Pages 19, 25, 43
www.sdp-si.com

Diequa Corp.

Pages 28, 69
www.diequa.com

Force Control industries

Page 17
www.forcecontrol.com

Forest City Gear

Page 3
www.forestcitygear.com

ITW Heartland

Page 36
SpiroidGearing.com

JIE USA

Page 67
www.jie-drives.com

Lafert North America

Page 35
www.lafertna.com

McInnes Rolled Rings

Page 18
www.mcinnesrolledrings.com

Miki Pulley

Page 38
www.mikipulley-us.com

Molon Motor and Coil Corp.

Page 41
www.Molon.com

Motion Industries

Page 31
motionind.biz/3iezqjv

NES Bearing Co. Inc.

Pages 29, 42
www.nesbearings.com

Nichiei Co. Ltd.

Page 59
www.nichiei-ind.com/english/

Nordex Inc.

Page 69
www.nordex.com

Philadelphia Gear

Page 9
PhilaGear.com/MyMission

Quality Bearings & Components

Pages 25, 43
www.qbcbearings.com

Quicksilver Controls

Page 2
www.QuickSilverControls.com

R+W America

Page 7
www.rw-america.com

RBI Bearing Inc.

Page 5
www.rbibearing.com

Regal Beloit

Page 13
Regalbeloit.com/IP69K

Schaeffler Group

Back Outside Cover
www.schaeffler.us

SDP/SI

Page 19
www.sdp-si.com

SEW-Eurodrive

Inside Back Cover
www.seweurodrive.com

SIPCO i.Mak

Page 69
www.sipco-imak.com

SMT

Page 15
www.smartmt.com/masta

Twin Spring Coupling LLC

Page 52
www.twinspringcoupling.com

U.S. Tsubaki

Page 31
www.ustsubaki.com

Worldwide Electric Corp.

Page 12
worldwideelectric.net

Zero-Max

Page 89
www.zero-max.com

Power Transmission Engineering®

FREE SUBSCRIPTION

20PTEALL

Please Respond

Your response ensures that we deliver the magazine only to those who want it. It also gives us the vital information we need to serve you best.

- YES** I want to receive/continue to receive **Power Transmission Engineering**
- NO** Thanks anyway, but I don't need the world's best publication on mechanical components.

Name _____ (please print) Job Title _____

Signature _____ (required) Date _____

How would you like to receive Power Transmission Engineering?

- PRINT Version (Verify mailing info below)
- DIGITAL Version (E-mail required)
- BOTH Print AND Digital (E-mail required)

E-mail _____ *

***You can OPT OUT of your e-mail subscription at any time.**

How is THIS LOCATION involved with power transmission products? (Check all that apply)

- WE MAKE power transmission products
- WE BUY power transmission products
- WE SELL power transmission products (Distributors, sales reps, etc.)
- WE DESIGN products with power transmission components in them
- Other (please describe) _____

What is your company's principal product or service? _____

MAILING INFORMATION

NAME:

JOB TITLE:

COMPANY:

ADDRESS:

- Check if this is a home address

CITY:

STATE/Province:

ZIP/Postal Code:

PHONE:

FAX:

If your label is incorrect or incomplete, please update it above!

FAX to 1-847-437-6618

SCAN to: subscribe@powertransmission.com

Time to Turn the Page!

Matthew Jaster, Senior Editor

My favorite book as a very young lad was *The Monster at the End of This Book* by Jon Stone and illustrated by Mike Smollin (1971) that involved Grover from *Sesame Street* begging children to stop turning pages to avoid the terrible, ferocious blue beast that waited patiently on the last page. Spoiler alert: it was Grover the whole time and the reader had absolutely nothing to be afraid of.

2020 has had a completely different picture book vibe.

Each month that passed the news became worse. No travel, no large gatherings, no cinema, no sporting events, you know how March–June played out, I'm sure I don't need to remind anyone that it was an awful period of time.

COVID-19 sucked the fun and sun out of most of 2020, taking great manufacturing/engineering events like IMTS in Chicago and Hannover Messe in Germany out and putting them in a home office near you.

My booth visits to learn about new technology were replaced by online video presentations with Internet speeds that felt like I was logging into AOL in the early 1990s. I spent some serious quality time with that one guy eating potato chips during virtual meetings (crunch, crunch, breathe, crunch, crunch breathe).

Enough is enough.

I'm not only turning the page on 2020 — I'm taking the year completely out of the equation I call life. I wasn't prepared to live out *12 Monkeys* or *Contagion* this year, I simply wanted to write about manufacturing and engineering technologies that fascinated me.

But guess what? I still did.

Somehow — through this post-apocalyptic carnage — I managed to stay extremely productive even though I was spending a majority of my time in one room in the house (the secret — and don't tell anyone this — is bourbon, lots of bourbon).

In 2020, I scheduled phone interviews while my kids screamed about math problems in the background. In 2020, I interviewed world leaders of bearing technology while my dog barked at our mail lady. In 2020, I played a weekly Zoom game in my head trying to figure out how many people were *actually listening* to the topic at hand — apparently, not potato chip guy.

I probably learned *more* about gear and power transmission technology in 2020 because I could attend additional events virtually.

Sure, there was a learning curve at first, but at one point in October I was attending three events at once, via a desktop computer, a laptop, and an iPad. My desk looked like the bridge of the Starship Enterprise. I found the IoT solutions webinar I was attending at the time extremely ironic.

I was no longer just learning about IoT — I was assimilating.

The world sucked this year, plain and simple. I miss trade shows. I miss listening to an engineer in-person get excited about a new technology. I miss having a pint with my buddies from England and Germany after a five-day exhibition marathon.

Through the pandemic, we've all learned to adapt to the new world we'll be facing in the future. And I'd like to think we're better prepared thanks to some of the tools and technologies available today.



It's no coincidence that we try to emphasize the need for companies to invest in automation, IoT, robotics and additive manufacturing in the pages of this magazine — the pandemic proved that smarter manufacturing keeps the front door open and the products moving out of the warehouse.

So goodbye 2020. The monster wasn't at the end of this book, it's been with us the entire year.

The trick is to find new and creative ways — both physically and mentally — to maintain just a hint of normalcy.

And just keep turning pages. **PTE**

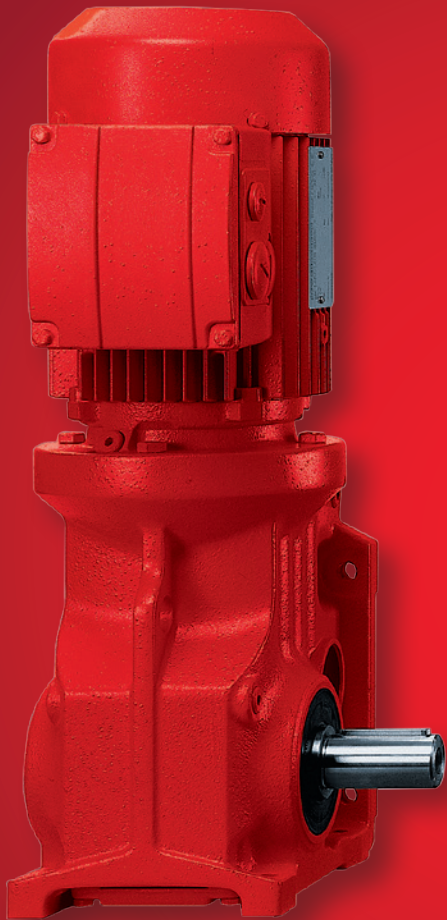
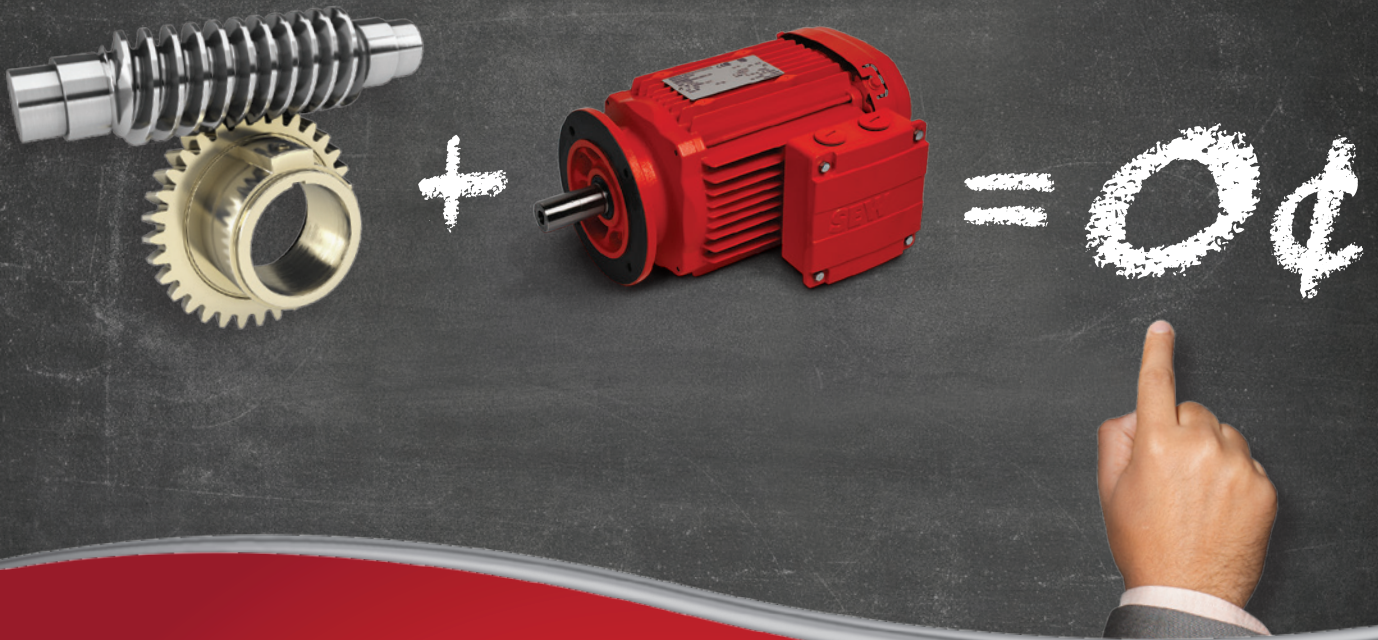

Makes no cents!

Adding an inefficient single-stage worm gearbox to a premium efficient motor doesn't make sense if you are trying to save money.

Why gain 2-3% energy savings with a more efficient motor and then lose 50% or more through the worm gear?

Solution: Use a helical-bevel gearmotor from SEW-EURODRIVE and obtain 96% efficiency. Now that makes a lot of cents!

**SEW
EURODRIVE**

— Driving the World —

We pioneer motion

CONCEPT1™ Single-Point Automatic Lubricator



The right grease in the right quantity at just the right intervals

Engineered to ensure optimal lubrication in a broad range of industrial machines and devices, CONCEPT1 from Schaeffler eliminates the need for time-consuming manual lubrication procedures, while preventing lubrication mistakes such as over- or under-greasing that can cause unplanned plant equipment downtime.

Easy to install and operate, CONCEPT1 can reduce plant maintenance costs by as much as 25% when compared to manual lubrication procedures.