

Power Transmission Engineering®

OCTOBER 2017

LUBRICATION

- **Guide to Bearing Lubrication**
- **How Lithium Grease Ages**

**TRENDS in
GEARMOTORS
WIND ENERGY
REPORT**

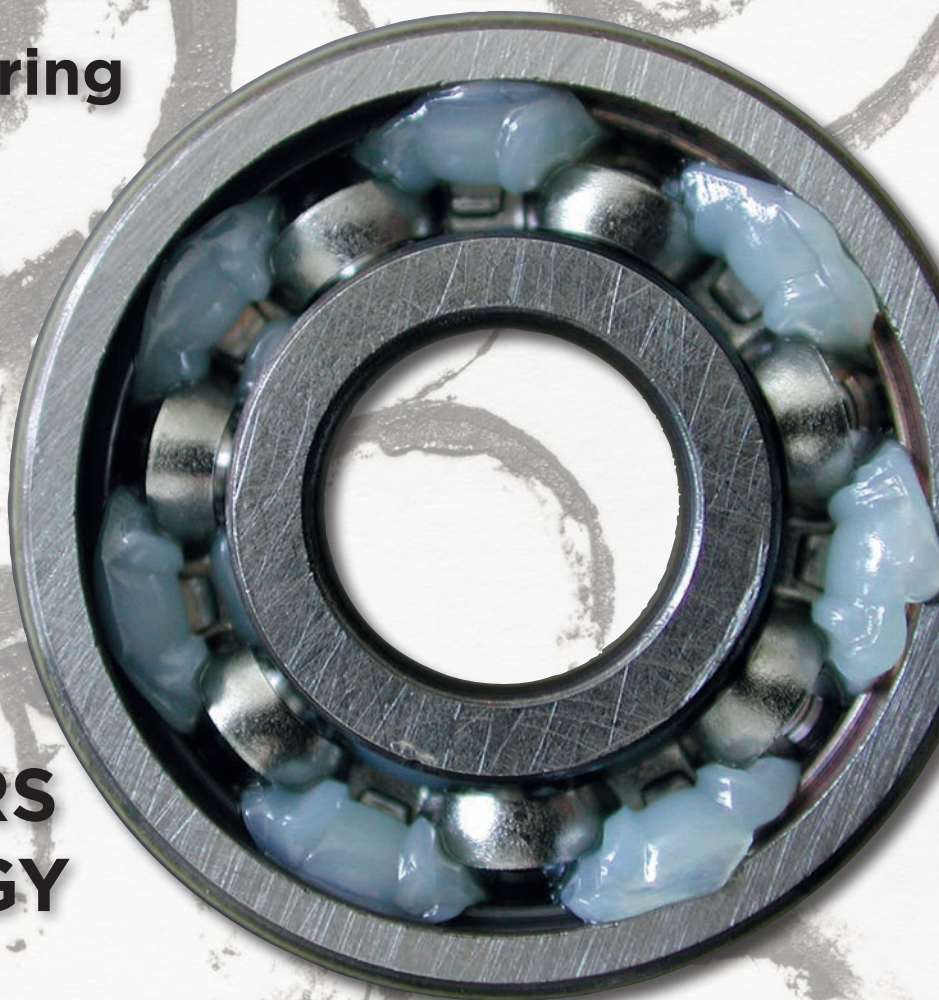

Who says you need a brush to create a masterpiece?



Brother Brushless DC Motors... redefining the art of efficiency.

- Virtually maintenance free; lubricated and sealed for life
- Extremely configurable; several shaft configurations and custom options available
- Highly efficient with quiet helical and hypoid gearing
- Very safe 12-48VDC motors with a wide speed control range

brother
at your side

866.523.6283

BrotherGearmotors.com

Call us today for a sample gearmotor to try out.

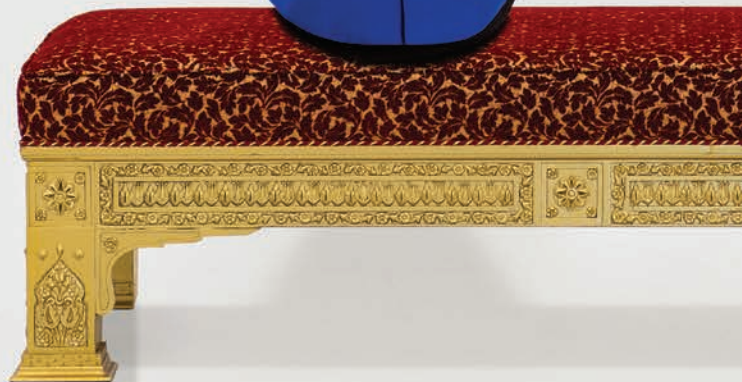

Power Transmission Engineering®

OCTOBER 2017

[26]



[20]

FEATURE ARTICLES

- [20] **Gearmotors: Familiar Goals, New Solutions**
Gearmotor manufacturers are finding new ways to push the envelope.
- [26] **U.S Wind Power Blowing Hot As New Installations Flourish**
A U.S. wind energy report that might surprise you.

TECHNICAL ARTICLES

- [30] **Guide to Proper Bearing Lubricating Procedures**
Understanding critical bearing lubrication procedures.
- [38] **A Model for Shear Degradation of Lithium Soap Grease at Ambient Temperature**
Shear degradation of lithium 12-hydroxy stearate grease is measured using in-house-developed Couette aging machine.
- [48] **Baldor Motor Basics — Part 8**
Premium efficiency motors.

Vol. 11, No. 7. POWER TRANSMISSION ENGINEERING (ISSN 2331-2483) is published monthly except in January, May, July and November by Randall Publications LLC, 1840 Jarvis Ave., Elk Grove Village, IL 60007, (847) 437-6604. Cover price \$7.00. U.S. Periodicals Postage Paid at Elk Grove Village IL and at additional mailing offices. Send address changes to POWER TRANSMISSION ENGINEERING, 1840 Jarvis Ave., Elk Grove Village, IL 60007.

Randall Publications LLC makes every effort to ensure that the processes described in POWER TRANSMISSION ENGINEERING conform to sound engineering practice. Neither the authors nor the publisher can be held responsible for injuries sustained while following the procedures described. Postmaster: Send address changes to POWER TRANSMISSION ENGINEERING, 1840 Jarvis Avenue, Elk Grove Village, IL, 60007. ©2017 Contents copyrighted by RANDALL PUBLICATIONS, LLC. No part of this publication may be reproduced or transmitted in any form or by any means, electronic or mechanical, including photocopying, recording, or by any information storage and retrieval system, without permission in writing from the publisher. Contents of ads are subject to Publisher's approval.

Power Transmission Engineering

VOL. 11, NO. 7

SUHNER Transmission expert.



Flexible shafts for special machinery

Efficient automation starts with efficient shafts.



SUHNER MANUFACTURING, INC.
Rome, GA 30161
706-235-8046
www.suhner.com
info.usa@suhner.com

SUHNER
EXPERTS. SINCE 1914.

CUSTOM TUBULAR COMPOSITE COMPONENTS

QA1's Advanced Materials Division is able to take your composite concept from initial design to full production, all at our facility in Lakeville, MN. Because everything is designed and manufactured in-house, QA1 can tailor the product to your needs.

- Application and design engineering
- 3D modeling, simulation and prototyping
- Testing and product validation
- Manufacturing and quality control



ISO 9001:2008 Certified

QA1

P: 800.721.7761 F: 952.985.5679
QA1.net/custom sales@QA1.net

[04] PTEExtras

Catch up—www.powertransmission.com—for latest videos, blog postings, social media and events.

[06] Publisher's Page

What's on Your Menu.

[08] Product News

The latest motion control and mechanical power transmission products.

[36] Engineering sMART

Products and services marketplace.

[56] Industry News

Siemens and **HP** partner on 3-D printing, **Continental** plant celebrates 50th, new hire at **Forest City Gear**; plus other news from around the industry.

[60] Calendar

November 3–9: IMECE, Tampa, Florida;
December 4–7: CTI Transmission Symposium, Berlin, Germany

[62] Advertiser Index

How and where to reach every supplier in this issue.

[63] Subscriptions

Free subscriptions, anywhere in the world.

[64] Power Play

The Long and Short of It.

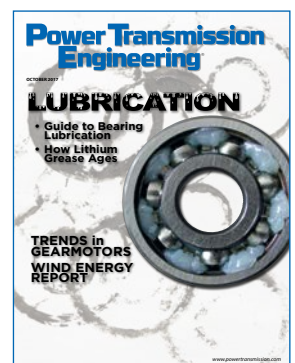

Inset photo courtesy of Klüber Lubrication

REDEFINING HIGH-PERFORMANCE SYNTHETIC GEAR LUBRICANTS

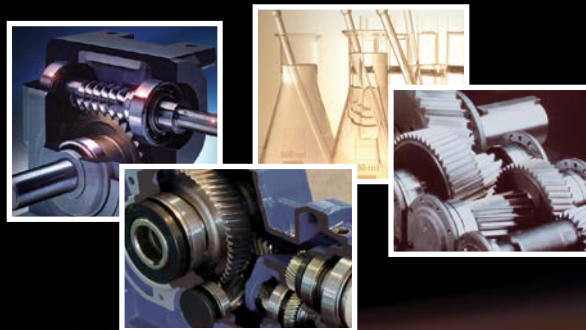

Lubriplate® SYNTHETIC GEAR OILS

More and more gear manufacturers are specifying Lubriplate Lubricants for their machinery. Why? With 146 Years of Lubrication Experience, they know Lubriplate has the Quality Products and Services to meet their needs, the needs of their equipment and the needs of their customers.

SYN LUBE SERIES

High-Performance, 100% Synthetic, Polyalphaolefin (PAO)-Based Fluids. Compatible with Petroleum-Based Oils for Easy Conversion. Available in ISO Grades 150 through 1000.

SYN LUBE HD SERIES

Heavy-Duty, Polyalphaolefin (PAO)-Based Synthetic Gear Lubricants. Meets AGMA EP (Extreme Pressure) Requirements. For Heavy-Duty Applications.

SYNTHETIC WORM GEAR LUBRICANT

100% Synthetic, Polyalphaolefin (PAO)-Based Fluid, ISO 460 Grade. Formulated Especially for Worm Gear Applications. Provides Excellent Oxidation Resistance.

PGO & PGO-FGL SERIES

Ultra High-Performance, Polyalkylene Glycol (PAG)-Based, Gear Lubricants. ECO-Friendly - Extended Service Life, Energy Conserving. PGO-FGL Series is NSF H1 Registered, NSF/ISO 21469 Certified, Food Grade.

SFGO ULTRA SERIES

NSF H1 Registered, NSF/ISO 21469 Certified, Food Machinery Grade. High-Performance, 100% Synthetic, H1 Fluids. Provides Excellent Oxidation Resistance.

The Brand OEMs Can Trust
When Specifying Lubricants
For Their Machinery ✓



PGO-FGL and SFGO ULTRA SERIES OILS Are Fortified With Lubriplate's Proprietary Food Grade Anti-Wear Additive **X^{TREMITY}**.

To Learn More About Lubriplate's Products and Services Visit www.lubriplate.com



Lubriplate
Lubricants

Newark, NJ 07105 / Toledo, OH 43605 / www.lubriplate.com
Contact Ellen Girard, Lubriplate's OEM Marketing Analyst
Tel: 908-489-7355 / E-mail: egirard@lubriplate.com



Backed By:



Complimentary Extra Services Package

Plant Surveys / Tech Support / Training
Color Coded Lube Charts & Machine Tags
Lubrication Software / Follow-Up Oil Analysis

MFG Day

While Manufacturing Day is officially Oct. 6, companies and community organizations plan their events on any date in October that works best for them. Visit www.powertransmission.com to see updates on events taking place in the PT community all month.

**PTE Videos**

Check out www.powertransmission.com/videos for the latest educational and training videos from Maxon Motors, Motion Industries and Gates. Please send your PT videos to mjaster@powertransmission.com to be included on our website.



16th International Congress and Expo

CTI Symposium

Automotive Transmissions, HEV and EV Drives

4 - 7 December 2017, Berlin, Germany

Event Spotlight**CTI Symposium 2017 Germany**

The International CTI Symposium in Berlin, Germany and its flanking specialist exhibition is the international industry event in Europe for people seeking the latest information on developments in automotive transmissions and drives for passenger cars and commercial vehicles. For more information, visit www.powertransmission.com/news/8304/CTI-Symposium-2017-Germany/.

Stay Connected

Follow us on Twitter
twitter.com/#!/PowerTransMag



Connect with us on LinkedIn
www.linkedin.com/groups/Power-Transmission-Engineering-PTE-2950055



Subscribe Online
www.powertransmission.com/subscribe.htm

Power Transmission Engineering**Randall Publications LLC**

1840 Jarvis Avenue
Elk Grove Village, IL 60007
Phone: (847) 437-6604
Fax: (847) 437-6618

EDITORIAL**Publisher & Editor-in-Chief**

Michael Goldstein
publisher@powertransmission.com

Managing Editor & Associate Publisher

Randy Stott
wrs@powertransmission.com

Senior Editor

Jack McGuinn
jmcguinn@powertransmission.com

Senior Editor

Matthew Jaster
mjaster@powertransmission.com

Associate Editor

Alex Cannella
alex@geartechnology.com

Editorial Consultant

Paul R. Goldstein

ART**Art Director**

David Ropinski
dropski@powertransmission.com

ADVERTISING**Advertising Sales Manager & Associate Publisher**

Dave Friedman
dave@powertransmission.com

China Sales Agent

Eric Wu
Eastco Industry Co., Ltd.
Tel: (86)(21) 52305107
Fax: (86)(21) 52305106
Cell: (86) 13817160576
eric.wu@eastcotec.com

Materials Coordinator

Dorothy Fiandaca
dee@randallpublications.com

CIRCULATION**Circulation Manager**

Carol Tratar
subscribe@powertransmission.com

Circulation Coordinator

Barbara Novak
bnovak@powertransmission.com

RANDALL PUBLICATIONS STAFF**President**

Michael Goldstein

Accounting

Luann Harold



Your ball screw Your servomotor Our coupling

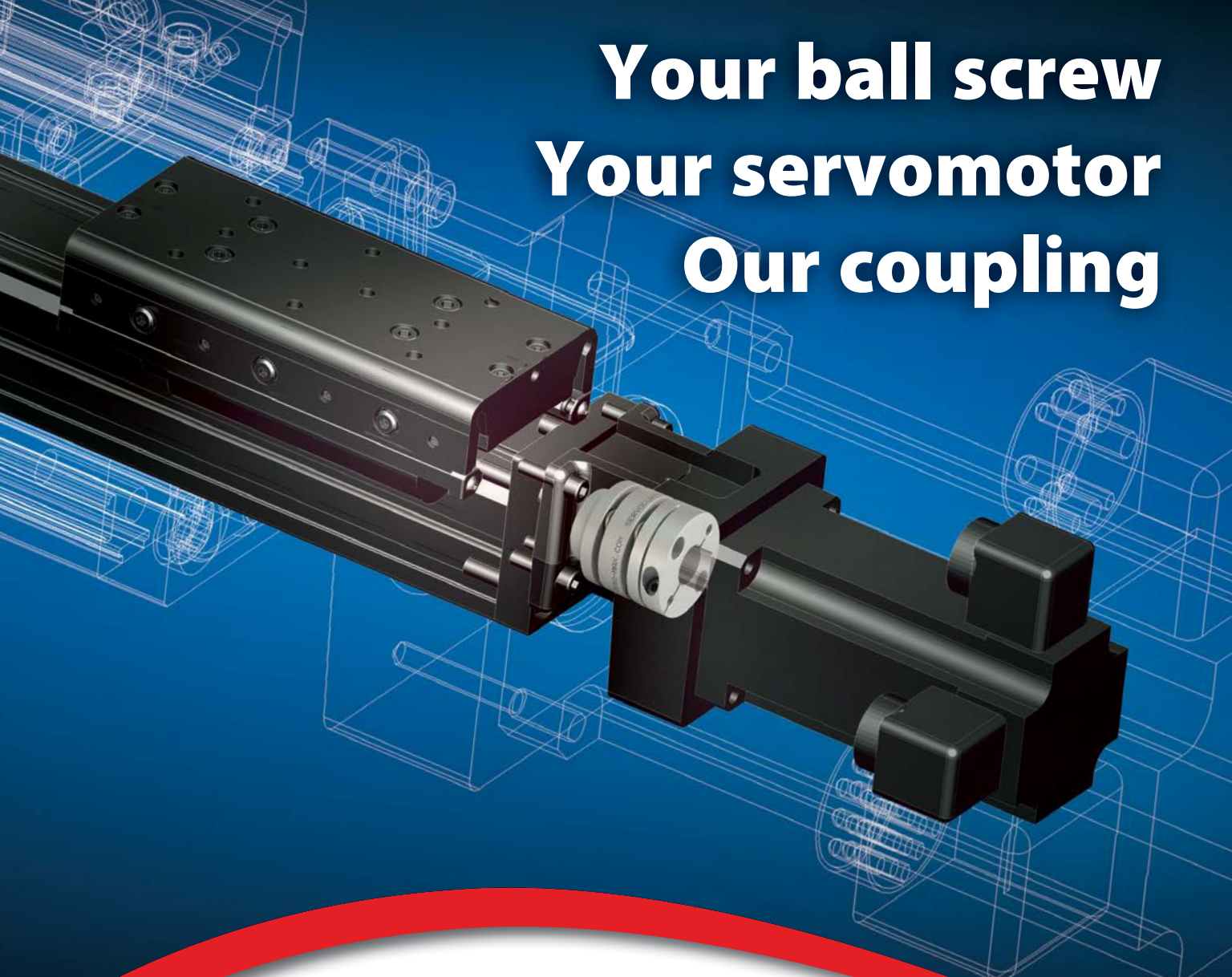

Together a winning combination for today's servomotor applications.

Our ServoClass® couplings have been recently redesigned to enable your actuator to go even faster and achieve the positional accuracy that will take your designs to the next level. Our couplings will do all this with low bearing loads.

3 New sizes now available.

Now, size, select and see the right ServoClass® coupling solution for your application with Zero-Max 3D CAD files.

Check our FAST deliveries.



What's on Your Menu?

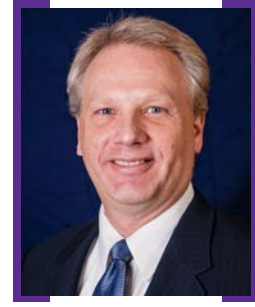

With Thanksgiving right around the corner, it's hard not to think of the smorgasbord most of us experience on America's most food-centric holiday. If your family celebrates like mine, then there's always plenty of food—and more importantly—plenty of choices.

In fact, you can always tell it's going to be a great Thanksgiving meal when you realize halfway through passing the food around that your plate just isn't big enough.

Here at *Power Transmission Engineering*, we like to think of our magazine as the Thanksgiving dinner of content. Our goal is to give you a heaping plate of information every issue. We want to give you more choices than you can possibly consume, and we want each choice to be so good that you don't want to pass it up. In other words, we want to leave you wishing for a bigger plate.

This issue's main course is our focus on lubrication, that oft-overlooked but vitally important aspect of nearly every mechanical system. Klüber Lubrication has provided us with the "Guide to Proper Bearing Lubricating Procedures," which you can read beginning on page 30. The article gives a step-by-step process to make sure your rolling element bearings operate smoothly and efficiently without generating excess heat.

We also have a research paper that explores and quantifies the aging mechanisms in lithium soap grease. Read "A Model for Shear Degradation of Lithium Soap Grease at Ambient Temperature," beginning on page 38, if you'd like to know more about how and why greases fail.

But there's more to turkey dinner than just turkey. So we've also included the side dishes of gearmotors and energy.

Associate Editor Alex Cannella's article on gearmotors ("Familiar Goals, New Solutions," page 20) covers a number of significant trends in the gearmotor industry. With expert perspectives from Baldor, Brother International, Framo-Morat, Lenze, Parker Hannifin, Rexnord, SEW-Eurodrive and Siemens, this article gives a broad overview.

Senior Editor Jack McGuinn tackles the wind turbine industry with his article, beginning on page 26 ("U.S. Wind Power Blowing Hot as New Installations Flourish"). The article takes a look at the many factors influencing the continued growth of the wind turbine industry in the USA and what it means for suppliers of gears, gearboxes, bearings and related components and systems.

Also touching on the theme of energy is the latest installment in our Baldor Basics series. This issue, Edward Cowern explains premium efficiency motors, including why they save you money in the long run, along with some of the important considerations and pitfalls to avoid. He's also provided a handy Q&A section at the end to answer some of your basic questions about premium efficiency motors.

Every issue we try to give you plenty of meat and potatoes by including as many different in-depth articles as possible on different topics of relevance. But we also provide the gravy and the dressing in the form of our news sections and departments. Always up front (beginning on page 8) you'll find Product News, with the latest in technology for power transmission and motion control components. And if you want to know what else is happening around the industry, just check out our Industry News section, beginning on page 56.

And don't forget the dessert, which around here we call "Power Play." This issue, Senior Editor Matthew Jaster tells you about the 10,000 Year Clock, which requires bearings that will run for 350 million cycles (see "The Long and the Short of It," page 64).

Caution: After reading all of the above, you may experience the urge to watch football and take a nap. Seriously, though, we hope we've done a good job filling your plate with the type of content you want and need. If you'd like to let us know how we're doing, please send an e-mail to wrs@powertransmission.com.

P.S. If you're looking for seconds, there's plenty available on our website. The PTE LIBRARY has articles from every issue. Just type what you're looking for in the search box, and happy reading.

Right Choice. Unparalleled Reliability.



Whether you're designing a new material handling machine or replacing a unit that's seen better days, industrial gearmotors from Baldor Electric Company are the right choice to put your application in motion.

With unlimited custom capabilities and a wide array of drop-in replacement configurations in stock, every Baldor • Reliance® industrial gearmotor features proven technology, quieter operation and unparalleled reliability.

baldor.com 479-646-4711

- Drop-in Replacement
- Unlimited Custom Designs
- Right Angle and Parallel Shaft
- Industry Proven Technology
- Unmatched Quality

BALDOR • RELIANCE®



Siemens

OFFERS EFFICIENT MACHINE TOOL OPERATION WITH SINUMERIK SOLUTIONS

At EMO Hannover 2017, Siemens displayed an array of new hardware and software solutions for its integrated Sinumerik portfolio. This included integrated industrial software and automation technology designed to enable machine tool manufacturers to leverage the full productivity potential of the digital factory.

“The end-to-end digitalization approach taken by Siemens encompasses not only hardware, but also software across the entire value chain from design to machine tool application, enabling our customers from the machine tool industry to achieve a significant boost to their productivity. The combination of advancing digitalization and innovative automation technology provides the key to creating a sustainable competitive edge,” explained Head of Machine Tool Systems Uwe Armin Ruttkamp.

With its new *Sinumerik* CNC software release 4.8, Siemens is making a range of new functions available to significantly improve the speed, precision and safety of machine tools. Benefits of version 4.8 include facility for compensating unwanted axis nodding movements and protection against machine, tool and workpiece collisions. Nodding compensation (NoCo) is used to compensate for dynamic position deviations in one or more linear machine axes caused by acceleration processes. These position deviations are caused by what is known as mechanical compliance within the machine. NoCo compensates for the dominant position deviation by initiating a corrective movement in the relevant machine axis, enabling improved machining quality simultaneously with higher jerk and acceleration values. Nodding compensation can be used in conjunction with any technology, such as milling, multi-tasking, tapping, laser ma-



chining or water jet machining. NoCo is available in two variants: Eco and Advanced. The Eco variant is designed for dominant acceleration effects in which the compensation axis is combined with one influencing variable. Where there are several influencing variables which require several compensation axes, the Advanced variant is the option of choice.

The new *Sinumerik* software release 4.8 also comes with an advanced collision protection: Collision Avoidance Eco and Collision Avoidance Advanced. The Eco version enables simple, reliable machine protection by preventing collisions of the machine body with its own components within the work area. To achieve this effect in real-time, the assemblies which need protection are calculated as simple geometric bodies. This reliable collision monitoring system is available in all three operating modes: JOG, MDA and Automatic. The protected areas can be simply and efficiently engineered and visualized as a 3D image

at the control interface. The Advanced variant includes full machine, tool and workpiece protection. The software provided by the *Sinumerik* product partner *ModuleWorks* runs via an interface integrated on an external PC, and works together with the *Sinumerik* CNC in real-time to ensure that the machine, tool and workpiece can be continuously monitored and are dynamically protected during the stock removal process. The workpiece and tool data required is made available to the system during set-up. Collision Avoidance provides a permanent, high level of safety during operation.

For more information:
Siemens Industry, Inc.
Phone: (847) 640-1595
www.usa.siemens.com/cnc4you



CTI Symposium

Automotive Transmissions, HEV and EV Drives

4 – 7 December 2017, Berlin, Germany

www.transmission-symposium.com/en



Dr Stefan Sommer



Wolf-Henning Scheider



Rolf Najork



Prof. Dr Peter Gutzmer



Dr Wolfgang Warnecke



Dr Sven Beiker

Plenary Speakers



Tatsuya Osone



Lipeng Zheng



Alessandro Coda



Anders Nielsen



Prof. Dr Ferit Küçükay

Dr Stefan Sommer
CEO, ZF Friedrichshafen AG

Wolf-Henning Scheider
Chairman of the Management Board and CEO, Mahle Group

Rolf Najork
President of the Executive Board, Bosch Rexroth AG

Prof. Dr Peter Gutzmer
Chief Technology Officer, Deputy CEO, Schaeffler AG

Dr Wolfgang Warnecke
Chief Scientist Mobility, Shell

Dr Sven Beiker
Founder and Managing Director, Silicon Valley Mobility, LLC
Lecturer in Management, Stanford Graduate School of Business

Tatsuya Osone
Vice President Advanced Technology Development and CTO, Jatco Ltd

Lipeng Zheng
Vice President and Project Director, Great Wall Motor Transmission Research Institute

Alessandro Coda
Chief Technology Officer, CLEPA – The European Association of Automotive Suppliers

Anders Nielsen
Chief Technical Officer, Volkswagen Truck & Bus AB

CHAIRMAN OF THE CTI SYMPOSIUM
Prof. Dr Ferit Küçükay
Director of the Institute of Automotive Engineering, Technische Universität Braunschweig

1,350 Delegates

135 Exhibitors @ the Transmission Expo

40% International Participants

25 Countries

Panel Discussion

“How will future mobility requirements change powertrain and transmission?”



Sponsors



McINNES
ROLLED RINGS

OUR
RINGS
MAY BE
FORGED,
BUT OUR
REVIEWS
ARE NOT.



Jobs always ship within a week —
DEFINITELY no complaints!
Thank you all for doing such an
awesome job! Keep up the
great work!

*Gear Manufacturer /
Southeast USA*

1.800.569.1420
www.McInnesRolledRings.com
533 E 12TH STREET • ERIE, PA 16511

ITAMCO

RAMPS UP ADDITIVE MANUFACTURING WITH EOS PRINTER

ITAMCO (Indiana Technology and Manufacturing Companies) is delivering components to the medical device industry made with their new EOS M 290 additive manufacturing printer.

The EOS printer was delivered in June 2017 and ITAMCO was shipping components to a medical device supplier in August. The fast ramp up is partially due to the experience the ITAMCO team gained while contributing to the development of additive manufacturing software. They were part of a consortium of manufacturers and universities that collaborated to develop the program through a multi-million dollar manufacturing initiative called “America Makes.” The software, named “Atlas 3D,” is now marketed through a division of ITAMCO.

The ITAMCO and EOS Partnership

Another reason for ITAMCO’s efficient entry into additive manufacturing was EOS—a global leader in additive manufacturing systems and solutions. “The EOS printer is the right tool for our complex components

made with DMLS (Direct Metal Laser Sintering) and the EOS team trained our staff and got us up and running quickly,” said Joel Neidig, director of research and development for ITAMCO. “The printer works seamlessly with Atlas 3D, too,” he added.

In addition, the technology team at ITAMCO quickly built a good working relationship with the EOS sales and support team. Jon Walker, area sales manager with EOS North America, said, “ITAMCO is an ideal partner for EOS because three generations of ITAMCO leaders have supplied traditional subtractive manufactured parts to some of the best known organizations in the world. Due to their reputation, ITAMCO’s investment in additive manufacturing validates the 3D printing market, especially in highly regulated industries where testing and validation of components or devices is critical. We’re thrilled that they have invested in an EOS M 290 3D printing platform, smartly positioning themselves to become an additive manufacturing leader in robust medical and industrial markets for the next three generations and beyond.”

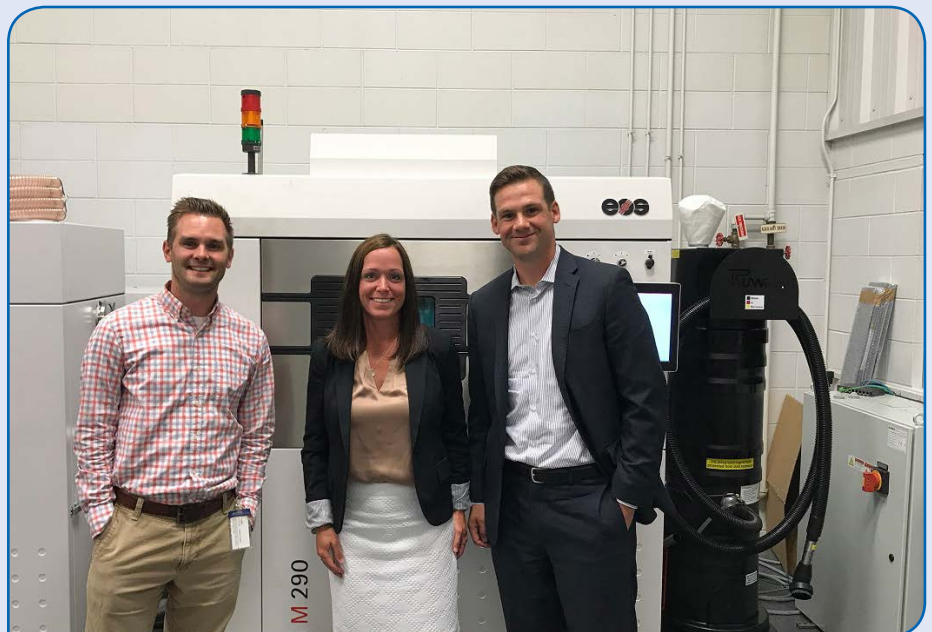

Left to right: Joel Neidig, director of research and development at ITAMCO, Jennifer Howe, area sales representative at EOS, Jon Walker, area sales manager at EOS.

Servicing the Medical Device Industry

The medical device industry is a relatively new market for the company that has serviced heavy-duty industries for decades. "Additive manufacturing is allowing us to do things we've not done before, like producing the smaller, more intricate components for the medical device industry," said Neidig.

Given ITAMCO's capabilities and their close proximity to numerous medical implant manufacturers in Indiana, the entry into this industry is a logical move. "We've hired two people from medical device companies to work for us," said Neidig. "Of course, we will continue to expand our presence in our current markets by offering additive manufacturing and the high-quality subtractive manufacturing that made us so successful."

Why Additive Manufacturing?

ITAMCO has been on track to include additive manufacturing in their offerings since the launch of their "Strategic Technology Initiative for Additive Manufacturing" in 2015. ITAMCO is using additive manufacturing to expand their market position in a global economy and to deliver real benefits to their customers. These benefits include faster turnaround, lighter yet stronger components, lower prices, design freedom, product customization and reasonably priced small-batch production.

For more information:

ITAMCO
Phone: (574) 936-2112
www.itamco.com

LM76

INTRODUCES PEGASUS SERIES 1 LINEAR BEARINGS

LM76 has developed corrosion resistant linear bearings. In space, deep under the sea, or in the harshest environments when there can be no "Plan B," Pegasus Series 1 Linear Ball Bearings can be counted on to perform. In some applications linear bearings will not move for days, weeks, months or even years, however, when called on to perform they must work as if they

just came out of the box. LM76's Pegasus Series 1 Linear Bearings feature Silicon Nitride (SiNi) Ceramic Balls in a shell with retainer and end caps all made from 440 Stainless Steel and then Armoloy coated.

Silicon Nitride was selected for the balls because it is: 40 percent lighter than steel, inert to chemicals (vapors, sea water, caustic washing

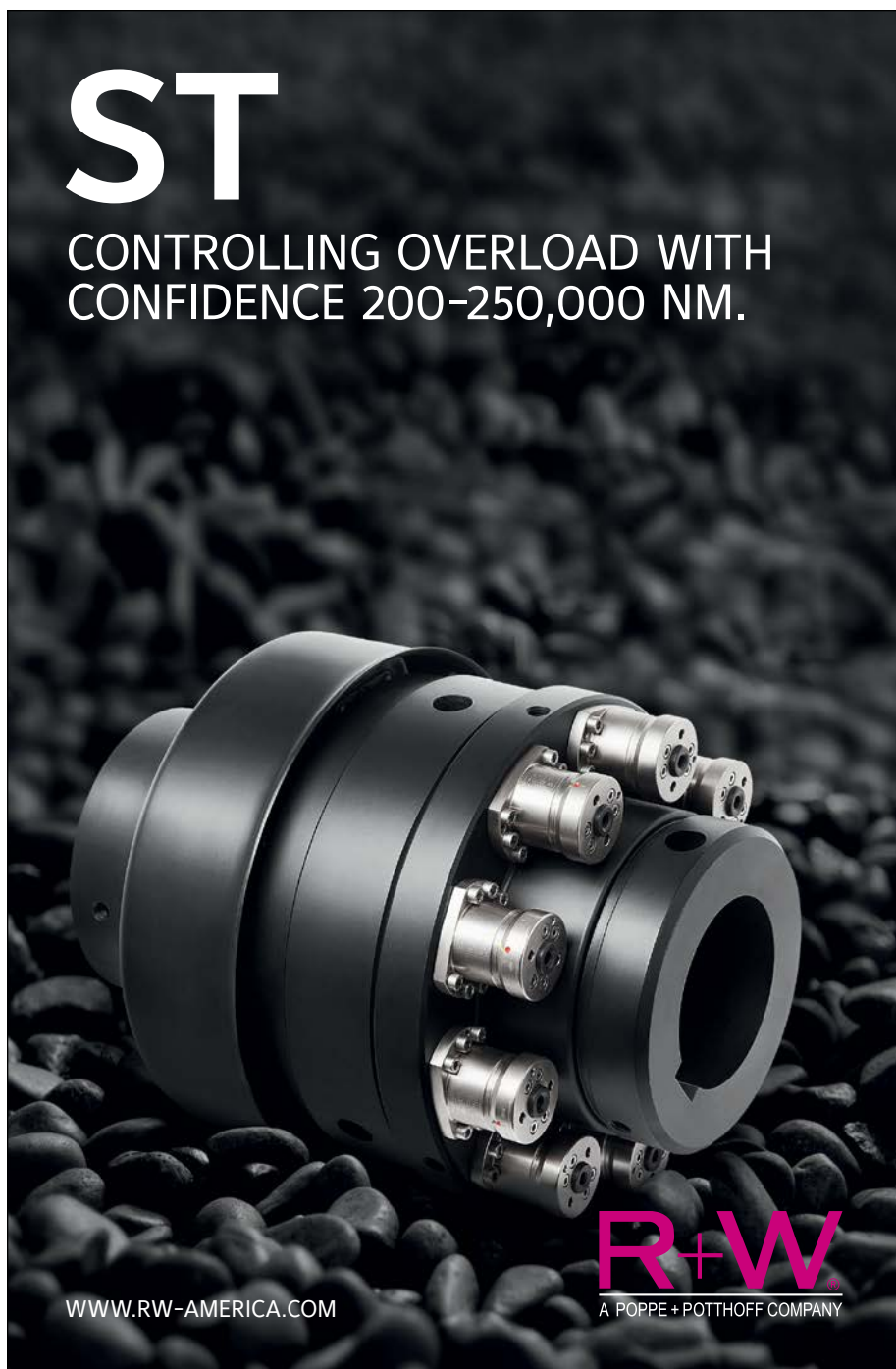

ST
**CONTROLLING OVERLOAD WITH
CONFIDENCE 200-250,000 NM.**

R+W
A POPPE + POTTHOFF COMPANY

WWW.RW-AMERICA.COM



THIN ENOUGH?

BXR Brakes

- Up to 480 in-lbs static
- Up to a 1.125" bore
- 19 watts or less
- Produced for over 10 years

Our Innovative design features a very thin profile, reducing weight and saving space.

For more information:
Call: 800.533.1731
www.mikipulley-us.com



and sterilizing solutions), capable of higher speeds and higher loads: (RC78 hardness), FDA compliant (used in surgical instruments), and does not corrode or support electrolysis.

The shell, bearing retainer and end caps are made from 440 Stainless Steel and coated with Armoloy TDCTM (Thin Dense Chrome). Armoloy is a hard (78Rc) coating with a micro-nodular surface texture. The coating's nodular finish reduces the amount of surface area in contact with the SiNi balls, reducing friction and extending life.

Pegasus Linear Bearings are available in two series (closed and open), and in four sizes (1.000", 1.250", 1.500" and 2.000"). Dynamic load rating for these bearings are: 1.000" 220 lbs, 1.250" 352 lbs, 1.500" 490 lbs, and 2.000" 858 lbs. Bearings are designed for zero clearance on Class L linear



shafting. For maximum performance they recommend LM76 Case Hardened 440 Stainless Steel shafting with Armoloy coating.

For more information:

LM76
Phone: (800) 513-3163
www.lm76.com

ACS

INTRODUCES MODULAR MOTION CONTROL SYSTEM

ACS Motion Control has developed a modular rack-mounted motion control system that quickly and easily integrates up to eight universal motor drives with power supplies and an optional EtherCAT motion controller to deliver a customized solution. The complete MP4U control system simplifies the development cycle and shortens the lead time for implementing a tailored solution. Completely self-contained in a compact 19" rack-mounted chassis, the MP4U can be a replacement for high power, high cost linear drive based solutions.

The unique MP4U control system can be configured with up to 8 axes of high performance UDM3U drives and/or ultra-high performance NPM3U (NanoPWM) drives, a 48 Vdc and/or 96 Vdc motor bus voltage power supply and an optional internal motion controller, with optional EtherCAT network slave (DS402 multi-axis drive) functionality to be released in 2018.

The MP4U drives are EtherCAT slaves that may be managed by either an external motion controller, such as the SPiPlusEC, or by an internal one. The internal controller is to be released



Faulhaber

OFFERS BRUSHLESS DC SERVOMOTOR WITH INTEGRATED SENSORS

The 2264...BP4 brushless DC servomotor from Faulhaber achieves a torque of 59 mNm with a weight of just 140 g and a diameter of 22 mm. Furthermore, the 2264...BP4 reaches up to 34,000 revolutions per minute.

“Since the history of modern micromotors began with the Faulhaber winding in 1947, winding technology has been one of our core competencies. With the new segment winding, which we developed for our brushless DC-motors of the BP4 family, we continue this tradition and open a new performance class,” said Product Manager Anne Schilling.

With the winding, the motor performance increases with the copper content. With the compact coil, a resilient shaft with 4 mm diameter and suitable bearing can also be installed. “As a result, the small motor can also readily serve as a direct drive, e.g., in



during 2018; its functionality is identical to the SPiiPlusEC.

The MP4U may also include an optional high-speed EtherCAT-to-EtherCAT bridge that enables to connect the entire system as a node in an EtherCAT network managed by any automation controller supporting DS402 protocol (SPiiPlusES functionality).

“The MP4U is a customizable motion control subsystem, ideal for meeting the needs of high-end motion control applications such as wafer inspection and metrology equipment,” said Jason Goerges, product marketing manager. “The LEGO-like MP4U system offers advanced motion control functionality and flexibility in a compact unit.”

The MP4U has a current range of 3.3A/10A (continuous peak) to 13.3A/40A. The compact unit has a height of 260 mm, width of 483 mm and depth of 306 mm.

For more information:

ACS Motion Control
Phone: (763) 559-7669
www.acsmotioncontrol.com



The Power of One²

Your Objective:

One face in perfect alignment with another. *For infinity.*

No problems. No distress. No delays.

That's the same objective you have for choosing your gear producer. Circle Gear's objective is to engage with every customer's objectives.

- ▶ One to 1000 gears
- ▶ Customer designed or reverse engineered
- ▶ Gearbox repair, rebuild or redesign
- ▶ OEM or end-users
- ▶ ISO 9001:2015 Certified

1501 S. 55th Court, Cicero, IL 60804
(800) 637-9335
(708) 652-1000 / Fax: (708) 652-1100
sales@circlegear.com
www.circlegear.com

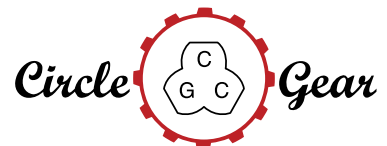

Spiral and Straight Bevel Gears (*Cut, Ground or Lapped*) • Spur Gears • Helical Gears • Long Shafts • Herringbone Gears • Involute and Straight Sided Splines • Internal Gears • Worm and Worm Gears • Racks • Sprockets • ISO Certified



Partnering with QualityReducer to provide
Gearbox repair, rebuilding and reverse-engineering.

handpieces of motorized tools.” Furthermore, the four-pole motor has a low inertia and is therefore very well suited for dynamic start/stop operation,” added Schilling.

In addition to the torque, the new motor is also characterized by its compact and economical sensors. Optionally analog Hall sensors precisely determine the position of the output shaft. The sensors are integrated in the motor, i.e., they do not require additional installation space. In most cases, they can replace an encoder, thereby making very compact and light solutions possible. If even more precision is required, e.g., with optical systems, in measurement systems or in semiconductor production, compatible optical and magnetic encoders are available. They can very easily be attached to the rear multifunction flange of the motor.

The 2264...BP4 is overload-resistant. It operates without wear-prone mechanical commutation and, as a result, has a service life many times longer



than standard DC-micromotors. Also unusual is the very large temperature range in which the motor can be used: it spans from -40 to +125°C.

“With these features, the 2264...BP4 is an ideal drive solution for nearly all applications of this size class — whenever space is tight or weight plays a decisive role yet a high torque is required,” Schilling said. She considers the two most important areas of application to be in handpieces of electrical tools and in industrial automation. “With electric loppers, electric screwdrivers

or motorized instruments for surgery, users often work with their devices for many hours. Thus, every gram that needs to be held and moved counts. At the same time, the tools should be fast, robust and effective. They need to operate at maximum performance so that every work step can be completed on the first pass.”

Similar requirements — at least with respect to the size-torque ratio — apply in many areas of factory automation, e.g., with grippers or robots, with mobile robots such as sewer robots, in aerospace with cabin equipment or with active prosthetics that can perform an ever larger range of functions for missing limbs. With suitable precision gearheads from Faulhaber, the 2264...BP4 can be optimally configured for practically every type of drive solution.

For more information:
Faulhaber (Distributed by Micromo)
Phone: (800) 807-9166
www.micromo.com

WORLD LEADING
INSPECTION & TESTING

SUPER PRECISION
CUSTOM BEARINGS



✓ SOURCE QUALIFICATION, FAILURE ANALYSIS
REVERSE ENGINEERING INSPECTION

✓ ENDURANCE, ENVIRONMENTAL,
IMPACT/STATIC LOAD TESTING



✓ CORROSION RESISTANT, HIGH TEMPERATURE,
HIGH FATIGUE LIFE BEARINGS

✓ SHORT LEAD TIMES, SMALL PRODUCTION
RUNS, COST-EFFICIENT SOLUTIONS

Napoleon Engineering Services - Visit us at nesbearings.com or call (877) 870-3200

Regal Beloit

DEBUTS LOCKING COLLAR DURING
PACK EXPO 2017

Regal Beloit Corporation, a leading manufacturer of electric motors, electrical motion controls, power generation and power transmission components, debuted the next generation of its SealMaster Skwezloc Locking Collar concentric locking collar during Pack Expo 2017 in Las Vegas. The new design accommodates commercial turned and polished shafting while improving lock reliability on turned ground and polished shafting.

The Skwezloc Locking Collar achieves improved lock reliability through an innovative circumferential groove on its inner ring bore that reduces stress on the inner ring when properly clamped to the shaft. A larger cap screw and collar also improve the clamping force and holding power to the shaft.

“Through extensive research, we found that the overwhelming majority of our customers prefer concentric locking for ease of installation, but needed a design that meets customer shaft tolerances,” said Ian Rubin, director of marketing, bearings, Regal Beloit Corporation. “By reducing the stress on the inner ring and adding a groove that decouples from the inner ring to improve elasticity, we’ve arrived at a design that meets the customer shaft tolerance need, especially for customers in the warehouse distribution, parcel distribution and baggage handling industries.”

The next generation Skwezloc Locking Collar also reduces stress concentrations when the collar is tightened through an optimized chamfer profile. It maintains the same simple single-screw installation of preceding models that prevents axial movement while also eliminating the risk of preloading the bearing.

For more information:

Regal Beloit
Phone: (608) 364-8800
www.regalbeloit.com



Wire, Fiber & Tow Tension Control



LOAD CELLS
AMPLIFIER



UNIVERSAL
DIGITAL CONTROLLER



CURRENT REGULATED
POWER SUPPLIES



PILLOW BLOCK
LOAD CELLS



CANTILEVER LOAD CELL



CARTRIDGE LOAD CELLS

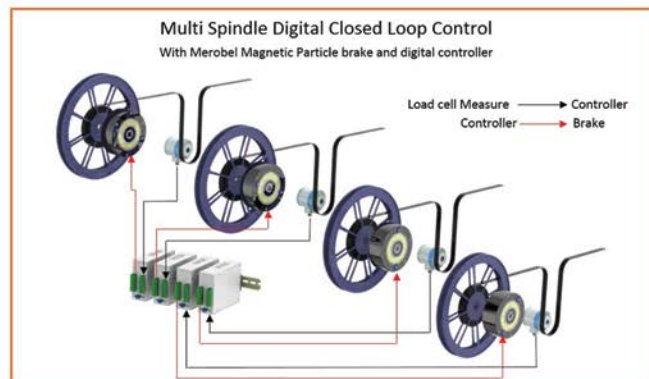

ANDANTEX

USA Inc.

andantex.com
info@andantex.com

Phone: 877-966-9151
1705 Valley Road, Wanamassa NJ 07712

MOLON

MOTOR & COIL CORPORATION



CERTIFIED
ISO 9001-2015
ISO 13485



Motor Solutions Thru American Innovation

We don't leave the manufacturing and engineering of our products to other countries.

**AMERICAN
MANUFACTURER
EST. 1954**

VISIT OUR WEBSITE:
www.Molon.com

Miki Pulley

CS ELECTROMAGNETIC ACTUATED CLUTCHES FEATURE
QUIET, ZERO BACKLASH OPERATION

Miki Pulley's CS Electromagnetic Actuated Clutches are durable, versatile and have excellent torque transmission features. CS Clutches provide an efficient connection between a motor and a load, providing low inertia, minimal drag and very quiet operation. They function utilizing the magnetic force generated by the energized coil providing engagement of input and output members of the clutch.

Available with three different armatures, Miki Pulley CS Clutches consist of a clutch stator, rotor and armature assembly. They feature an integrated bearing design, making mounting fast and easy while ensuring application concentricity and excellent system runout. CS Clutches operate well in temperatures from +14°F to +104°F (-10°C to +40°C).

Available in bores ranging from 10 mm to 15 mm, with brake torques ranging from 3.687 ft. lbs. to 236.02 ft. lbs. (5 Nm-320 Nm), the CS Clutch utilizes corrosion resistant materials, and is RoHS compliant like all other Miki products.

"Miki Pulley's CS Clutches stand apart from competitor's models, in that they incorporate specialized

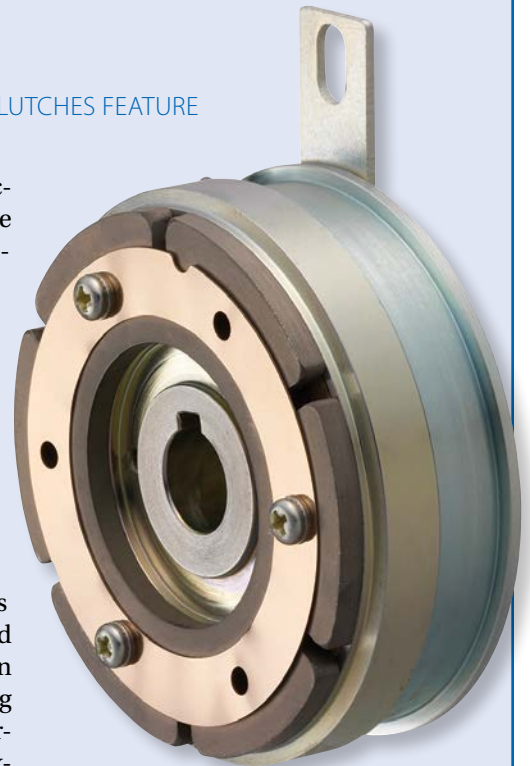

composites and alloys promoting durability and longer operational life," reports Jon Davidson, Miki Pulley sales specialist. "Miki Pulley's friction-type design operates smoothly and quietly, making them an ideal choice for digital printing systems and similar equipment requiring near noiseless operation."

For more information:

Miki Pulley US
Phone: (800) 533-1731
www.mikipulley-us.com

Drive Lines

EXTENDS BEVEL GEARBOX RANGE

A new size, the P-65, has been added to the Graessner PowerGear P range of bevel gearboxes available from Bedford, U.K.-based Drive Lines. Being 65 mm cubed in size, it is expected to prove very popular in a wide range of applications, such as for use with screw jacks to create vertical lifting and lowering mechanisms.

With miniature sizes recently added to the standard range, Graessner PowerGear P units are now available in 12 sizes from P27 to P450.

They are all of identical design and use and optimized bevel gear geometry that delivers increased torque

and high efficiency in a compact and lightweight package. These high performance gearboxes are available in flange, solid or hollow shaft versions.

PowerGear P gearboxes are characterized by high torque and low to medium input speeds, in a sturdy, rigid design that ensures the highest performance while being space and weight efficient. The optimized gearing delivers high torque ratings up to 7,000 Nm, while an optimized contact pattern assembly delivers uniform load distribution for increased reliability and longer life.

The gearboxes are available in four configurations. FL models provide an

input with hollow shaft and flange, and output with solid shaft on one or both sides. L models feature input and output with solid shaft, and output on one or both sides. FH models offer input with hollow shaft and flange, and output with hollow shaft and feather key groove. And H models offer input with solid shaft, and output with hollow shaft and feather key groove. Fretting-free torque transfer is achieved using a friction locked fit between the shaft and the bevel gear.

Offering input speeds up to 7,500 rev/min, the gearboxes are available in ratios from 1:1 to 5:1. A high efficiency rating of 98% provides opportunities to save energy costs. Lubricated for life, the gearboxes are virtually maintenance free under normal operating conditions.

With the input and output axes intersecting instead of being inline, a key benefit of the bevel gearbox is its ability to change the direction of rotation by 90°. The PowerGear P range builds on this ability by offering a compact and robust design that combines tapered roller bearings with a ductile iron housing. The result is a versatile right-angle gear which delivers high performance in a highlight compact and lightweight package.

With their high torque, compact dimensions, high efficiency and robust, long-life design, the PowerGear P gearboxes reset user expectations for power and precision, delivering low backlash and high transmission accuracy. Typical applications for the PowerGear P bevel gearboxes include industrial machinery in challenging sectors such as paper and print, textiles, iron and steel, defense and aggregates.

Where higher torques are required within the same footprint as the P series, Drive Lines also offers the PowerGear X version in nine gearbox sizes from 54 to 280. With a 1:1 ratio, the X version offers nominal output torque up to 5,500 Nm with input speeds up to 4000 rev/min. PowerGear gearboxes are also available in miniature versions and high speed versions, meeting the needs of the most diverse spread of applications.

Finally, Drive Lines offers food safe versions of the PowerGear range, using

stainless steel shafts and a gear housing coated with Duralloy-TDC which has been verified by Zurich-based independent test bureau Labor Veritas as safe for use as standard in foodstuff applications.

For more information:

Drive Lines
Phone: +44 (0) 1234 360689
www.drivelines.co.uk

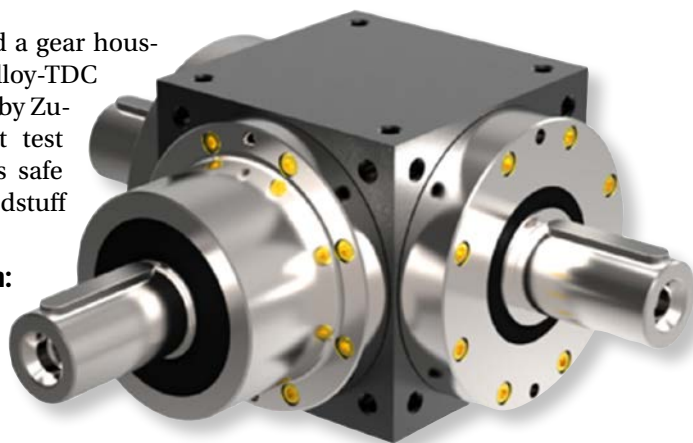

The Full Spectrum

Gear solutions made easy with one of the most comprehensive and versatile gear reduction lines in the Metric market. With over 45 years of proven performance, Lafert's power transmission products will let you push through even in the most demanding applications.

LAFERT NORTH AMERICA
Toll Free: 1.800.661.6413 | Fax: 1.905.629.2852
www.lafertna.com | sales@lafertna.com

SITI SPA
SOCIETÀ ITALIANA TRADING MEMBER OF THE SITI GROUP

Copyright Lafert North America 2013. All rights reserved.



**ISO Certified /
ITAR Registered /
Trace Certified**

- Standard Components
- Made to Print Parts
- Design & Engineering
- Gears, Pulleys & Racks
- Assemblies

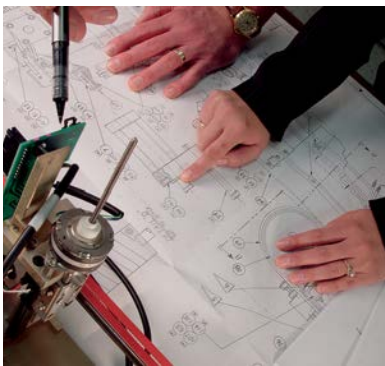

Nordex.com

sales@nordex.com
eng@nordex.com

Phone: (800) 243-0986
or Call: (203) 775-4877

Rexnord

OFFERS LONG SPAN XTSR AND 4-BOLT XTSR DISC COUPLINGS

Rexnord introduced the latest additions to its line of Thomas XTSR Disc Couplings, the Long Span XTSR (XTSRLS) and the 4-Bolt XTSR offering (an extension of the 8-Bolt and 6-Bolt configurations). Designed for applications primarily in the energy sector, the 4-Bolt XTSR and XTSRLS also have common applications in the industrial equipment and material handling sectors, including industrial fans and centrifugal compressors, blowers, ANSI & API pumps, chemical processing, gas turbines, pulp & paper, and oil & gas, among others.

The XTSRLS Disc Coupling was designed for longer spans, up to 349 inches. “The XTSRLS is an exciting new product that replaces legacy Thomas SN, SN-GA, and SN-Single products that have a very mature product life-cycle. It enables us to bring value to our end-users by featuring a modular design, higher torque capacity and an optimized bore design that is suited for floating shaft applications requiring long distances between shaft ends, such as pulp & paper machines, turbines, and compressors,” says Chino Imediegwu, director global product management for couplings and shaft management solutions products.

The new 4-Bolt XTSR disc coupling design offers a more optimal solution



The new range of optimized sizes “brings a significant competitive advantage and plugs a hole in our XTSR disc coupling product line by offering right-sized solutions for our customer’s applications where we were oversized in the past,” adds Imediegwu.

The 4-Bolt XTSR disc Coupling and the XTSRLS products are available for order in all markets served globally.

For more information:

Rexnord
Phone: (866) 739-6673
www.rexnord.com

Yilmaz Reduktor

FILLING MARKET HOLES, MEETING CUSTOM DEMANDS

Yilmaz Reduktor has released several new products recently ranging from new planetary gearbox sizes to full drive train solutions, all of which have been focused on the construction sector.

Primary among their new offerings is the V Series hoist gearbox, which has been designed specifically for use in cranes. According to Metin Yilmaz, general manager at Yilmaz Reduktor, the company quickly found that it would need to design its V-Series to meet different design considerations than with past products.

“The main problem is that crane ap-

plications have completely different requirements to those of [gearboxes] used in general industrial applications,” Yilmaz said. “So most of the products were not specifically designed to the crane demands and they were not optimal.”

For most of those general industrial gearboxes, pitting resistance is a primary issue Yilmaz sees talked about often, but according to him, root strength is the most important factor they found in developing a gearbox to work specifically with a crane, since cranes operate in shorter, non-

continuous time spans than would be seen in most general industrial applications. In addition, the V-Series is not only a hoist gearbox — a rare beast on the market — but also in a mono-block housing to provide additional rigidity.

Yilmaz Reduktor's other new products all fall into a similar vein, filling holes in the market where there are few or diminishing options to for customers to choose from. For instance, Yilmaz noted that the supply of larger, higher-torque gearboxes has been shrinking, and so the company has stepped in to fill the gap with their H-Series heavy duty gearboxes and extended the series range up to 470,000 Nm. The company has also rounded out their portfolio with four different frequency inverters, which now allows them to offer full drive train solutions.

Another common theme amongst Yilmaz Reduktor's new products is that most are designed specifically for cement mixing. The H-Series, for example, got its extended range with cement factories, among other applications such as steel mills and under-

ground mining, in mind. The company has also released new versions of their planetary gearboxes that were designed for the express purpose of operating with cement mixers.

Some of these new designs may sound like incredibly niche products, but according to Yilmaz, this is all part of a larger trend towards custom-built gearboxes for individual customers. Yilmaz has found that the number of their customers asking for specialized gearboxes has increased over time from 10 percent to almost half.

"Every machine builder wants its machine to be compact as possible and an optimization is needed for the gearbox for the specific needs of the machine," Yilmaz said. "Therefore we have also designs for specific applications like sawing machine gearboxes, crane gearboxes, cement mixing gearboxes, agitators, plastic injection gearboxes, etc."

For more information:

Yilmaz Reduktor
Phone: +90 212 886 50 43
yr.com.tr

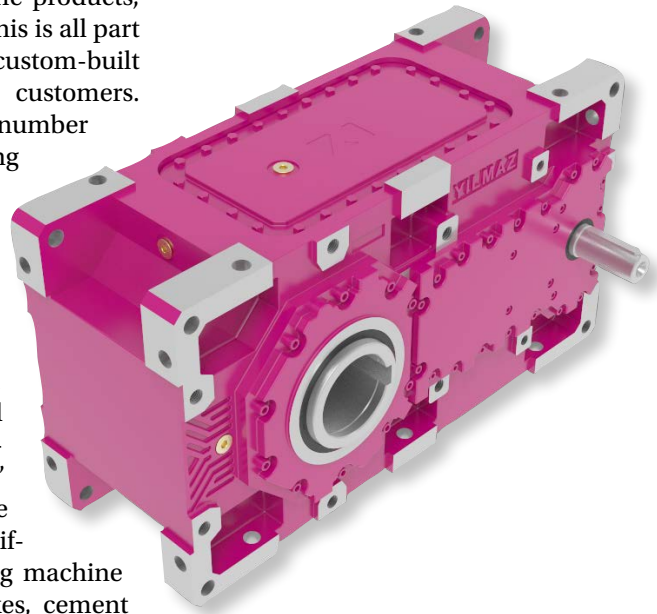

DieQua offers more gearboxes

Are You Selecting The Right Technology?

Whether your application is for precise motion control or for general power transmission, there are several gear technologies that can do the job. But which one does it best?

Only DieQua offers the widest range of gearmotors, speed reducers and servo gearheads along with the experience and expertise to help you select the optimal solution to satisfy your needs.

**If you are using gearboxes,
you should be talking to DieQua!**

DIEQUA
Corporation
www.diequa.com 630-980-1133

Power Transmission Solutions

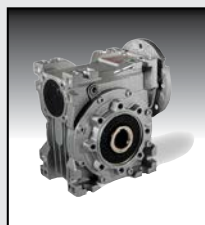

Worm Reducers

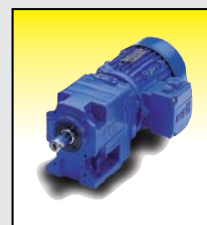

Helical Gearmotors



Spiral Bevel Gearboxes

Motion Control Solutions



Planetary Gearheads



Servo Worm Gearheads



Precision Cycloidals

Familiar Goals, New Solutions

Gearmotor manufacturers find new ways to push the envelope.

Alex Cannella, Associate Editor

It's almost possible to say that it's business as usual in the gearmotor industry. End user demands haven't changed much from past years, and manufacturers continue to improve their products in tried and true ways: smaller, lighter, more efficient, cheaper. Many of the big gearmotor manufacturers are putting out new products that don't so much push the industry forward as offer existing technology in fields they hadn't been covering before.

Many of those fields, however, are being targeted based on individual manufacturers' perceptions of where the industry is at and where it's going. Brother sees mobility becoming a key factor in motors in the future. Siemens is focusing their innovations on conveyor applications. Rexnord is working with the Internet of Things. Everyone is finding new ways to push the usual metrics forward.

Brother

MIND ON MOBILITY

Brother's most recent contribution to the industry is a brushless DC gearmotor, which is mostly just a translation of Brother's AC induction motor line into a DC gearmotor package. The gearmotor is lubricated and sealed for life, significantly reducing maintenance, and features a wide speed control range and several shaft configurations.

But according to the Vice President of Brother's Gearmotor Division, Matthew Roberson, even if their new gearmotor doesn't bring much new to the table for Brother, it does bring something new to the gearmotor industry, namely Brother's gearset design. Brother's gearboxes are designed to utilize hardened steel hypoid gearing as opposed to worm gearing, which translates into a higher efficiency design.

"A worm gear is great, it's been around forever, but once you start getting a little higher ratio, it becomes very inefficient," Roberson said.

And as Roberson sees it, efficiency is going to become increasingly important for Brother's gearmotors, because one

key factor is becoming more prevalent: mobility.

Brother's mind is on mobility, and they're seeing the demand for it everywhere. Factory and warehouse automation is on the rise, and with it the demand for light, portable gearmotors. The medical industry is similarly hungry for mobility, with equipment that needs to be light, mobile and ergonomically safe. Even with automation in other sectors, such as with autonomous vehicles beginning to handle last mile deliveries, size portability become paramount. Across the board, Brother is seeing mobility as a deciding factor, and they're responding.

And a primary factor to making Brother's gearmotors competitive in what they see as an increasingly mobile space is energy efficiency. Many of the aforementioned applications require battery power to function, and motor efficiency is a key factor to making sure that battery lasts as long as possible. While motor efficiency accounts for costs saved over time in energy costs at a factory, for mobile applications, better efficiency in all systems directly contributes to uptime, making it even more paramount.

"In portable applications, you're relying on battery power," Roberson said. "If you have inefficiencies in the gear section of your gearmotor, that's really just energy lost, which means drainage of the batteries and shorter life. So in mobile applications, which is where we're focused...the efficiency, not only of the motor but of the gearing, becomes important."

Siemens

DESIGNING FOR CONVEYORS

On the topic of lighter and portable is Siemens' Simotics S-1FG1 servo geared motor. As a servomotor attached permanently to a gearbox, it gets the best of both worlds: a smaller footprint without the usual adapter plate between them, as well as all the benefits of a compact, light servomotor.

The S-1FG1 is designed for use in material handling and conveyor applications. In particular, Siemens has designed



the S-1FG1 for situations that require rapid-fire positioning, such as in a diverter arm that needs to separate products out between two conveyor lines.

The real news coming from Siemens, however, is about their Simogear electric monorail gearmotor. Whereas the S-1FG1 is compact and light, Siemens' new electric monorail gearmotor is designed for heavy duty functions. It's designed specifically to carry heavy loads of up to 8,000 pounds in electric monorail and conveyor applications most commonly seen in the automotive industry.

Thanks to a helical bevel gear design, this electric monorail gearmotor is designed to bear those titanic loads with minimum wear on its gears to lengthen its lifetime. It was built with significant loads of radial and axial forces in mind. The gearmotor comes in 3-10 horsepower variations and utilizes a NEMA premium motor. Siemens, meanwhile, is looking at producing even more energy efficient versions of this motor in the future.

Baldor

KEEPING OIL IN AND WATER OUT

There are a few things that have changed around the factory at Baldor. For one, they've started using air gages when manufacturing their products, which allows for greater accuracy when repeatedly manufacturing parts by constantly checking for deviations in the process and adjusting them back into line when they start reaching defined tolerances.

But something that will affect end users a bit more directly is an adjustment they've made across all of their right angle and parallel shaft gearmotor lines regarding their seals. Baldor has replaced their old seals with new ones impregnated with friction modifiers, making them better at holding in oil. The change is proving beneficial for customers who install Baldor's gearmotors upside down or in a position where the oil rests directly on the seal.

While Baldor is updating their motors to keep liquids in, their latest release is focused on keeping them out. At Process Expo in September, they revealed a new and improved model for their washdown gearmotor line.

The new white washdown gearmotor is meant to replace the older model, which reached a far more limited market than Baldor had initially expected.

"What we ran into in the past is we'd actually sold white washdown gearmotors, but we primarily noticed that we were only selling to car washes," Tyler Lensing, product manager at Baldor, said. "And the reason for that was we had [a] finned extruded aluminum housing, so we decided that we needed a smooth body."

With fins on the housing, Baldor's gearmotor couldn't reach the food and beverage processing market that most washdown motors are designed for. Debris could settle and bacteria could grow between the fins, which would make keeping the gearmotors sanitary a difficult proposition.

Baldor's new white washdown gearmotor, however, returns with a round housing. The new product line mostly co-

Rotary Motion Control Products for Printing, Packaging, Converting, Medical, and Food Packaging Machinery.

Spiral Bevel Gearbox



Hollow Shaft

Solid Shaft

FEATURES

- 1:1, 2:1, 3:1
- 2 or 3 Shaft Options
- 14-32 mm Shaft
- < 6 Arc-min Backlash
- Adapt to Servo or Stepper Motor
- Hollow Output
- Same or Counter Rotation
- Zero Maintenance
- Stainless and Carbon Steel

Zero Backlash Couplings



Jaw

Disc

Encoder Disc

FEATURES

- 0.4 mm – 60 mm Bore Range
- 0.4 – 540 Nm
- 3000 - 10,000 RPM
- Metric/Inch Bore Sizes
- Competitor Drop-in
- Many Different Sizes
- Save Money, Lower Price

100% Customer Satisfaction. Buy with confidence in our high quality, low price and superior service in the industry

ROTARY TIMING
CONTROL PRODUCTS



FACT North America LLC
www.rototime.com Info@rototime.com
872-529-5747

opts features from the company's already established wash-down electric motors such as an o-ring between the in-plate and the stator band, neighboring gaskets where the conduit box meets the stator band and under the box lid, a threaded lead exit for sealing and a stainless steel seal washer on the shafts for both right angle and parallel shaft units. For Baldor, it's a good first step forward into a new industry, and it's a step that can always be iterated upon.

Lenze

OFFERING SMALL FORM FACTOR AND FLEXIBILITY

The latest from Lenze is their g350 gearmotor, which attaches their Smart Motor to a single-stage right angle gearbox with a minuscule form factor. Already an established product in Lenze's portfolio, the Smart Motor features multiple easy programming options, including five preset speeds and up to 20 seconds of programmed acceleration and deceleration. It also is capable of starting at 400 percent its normal torque, reducing the need to potentially oversize the motor. The g350 targets conveyor manufacturers with the main selling points of small form factor, flexibility and energy efficiency. Lenze has also optimized their marketing around the g350 to provide a simple portfolio of options to pick from. It comes in three sizes based on torque capacity, as well as options to come with or without brakes. In addition, plug-in shafts and bolt-on flanges are available for purchase.

But according to Alby King, electromechanical product manager at Lenze, drives, not gearmotors, are what's trending right now. King has noticed decentralized drives becoming increasingly prevalent in the market, and Lenze has started to receive customer requests for direct drives.

"Direct drive solutions often look as though they might take off and render gearboxes obsolete, but continue to be set back by lack of flexibility, size limits, complexity and cost," King said. "That said, they are coming down in cost and can offer advantages within certain markets."

SEW Eurodrive

EXPANDING PERMANENT MAGNET SOLUTIONS

SEW-Eurodrive's Movigear line of permanent magnet gearmotors are perpetually being updated and expanded upon. Much like Siemens and Lenze, the company is targeting the conveyor industry. And according to Brian Lambert, electronic product manager at SEW-Eurodrive, trends such as internet shopping's prevalence and the expansion of shipping hubs will only feed the trend further.

And so SEW-Eurodrive is positioning its Movigear line to capitalize on the trend. While the line has broad appeal for a number of industries, it's focused primarily on the food and beverage, parcel and airport handling and other conveying industries. The line features IE4 super premium efficiency, giving the gearmotor above-average efficiency, and a high torque overload capacity that reduces the need to oversize it.

The Movigear line was most recently updated to include new customizable connector options and is currently undergoing development to "work seamlessly" with the Movi-

C line of inverters, another of SEW-Eurodrive's products. The Movi-C line features a modular design that combines software modules, controllers, inverters and drive technology. It's designed with customization and easy startup and monitoring/diagnostics in mind, and can run both synchronous and asynchronous motor solutions in both open or closed loop configurations.

Parker Hannifin

MOVED AWAY FROM GEARMOTORS

Parker Hannifin has taken a long, hard look at customer feedback and their sales figures, and is opting to focus on gearheads and gearmotors as separate components.

Way back in 1998, when Parker Hannifin's gearhead division was still its own company called Bayside Controls, they released their first gearmotor to decent success. But despite the product's success, a majority of customers still wanted separate gearheads, citing ease and affordability of installation and replacement as more important buying factors than the smaller package a connected gearmotor provided.

"What we found was the majority of customers still want-

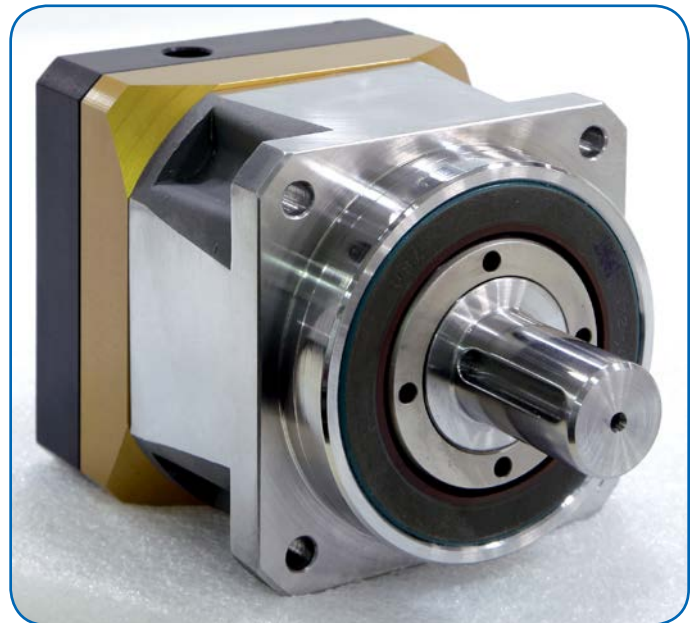

ed to buy a separate gearhead and a separate motor because we had made it so easy to mount a gearhead to the face of a motor," Jeff Nazzaro, gearhead and servo product manager at Parker Hannifin's Electromechanical and Drives Group in North America, said. "And the thought was 'well yeah, I know I'm not going to have as small an envelope, but when a gearhead is the mechanical wear component in a gearmotor, if I have a separate gearhead in the motor, I can just keep an extra gearhead on the shelf.'"

It was this "voice of the customer" that Parker Hannifin's gearmotor line needed to address. Gearmotors were always profitable, but gearheads were always better. And so a few years after acquiring Bayside, Parker Hannifin largely repurposed the group to focus on gearheads and motors separately.

“We found that the gearmotor had its tale of success, but the majority of the business still leaned towards a separate gearhead and a motor,” Nazarro said. “Parker Hannifin still offers gearmotors as a custom product, with the flexibility to provide other modifications such as custom windings, coatings for special environments, shaft modifications, etc. Doing it in this manner makes more sense for us and the customer, versus having an extremely long list of options on a standard product.”

Rexnord

“ALL ABOUT THE INTERNET OF THINGS”

For Rexnord’s Power Transmission Division’s VP of Marketing and Customer Care, Michael Miclot, the industry is “all about the Internet of Things.”

Most notably, Rexnord has implemented an onboard intelligence for their V-Class family of gear drives that’s connected to the Internet of Things. In plainer terms, the gear drive can not only connect to a wider system of machinery and controls, including PLCs, VFDs and interface devices, but it can also monitor its own condition, including temperature, vibration and oil quality/level as a form of preventive maintenance.

“Now you’ve actually got an intelligent device connected into your infrastructure that can set alarms and allow the user to prevent unplanned downtime,” Miclot said.

For example, the V-Class gear drive can replace oil sample tests by constantly monitoring its own oil levels and quality. Whenever quality begins to dip below accepted levels, the drive can notify the end user of the situation, often giving maintenance crew far more time to plan and execute maintenance without disrupting workflow than if the device had failed.

“We’re not talking you’ve got pending catastrophic failure within minutes,” Miclot said. “You’ve often got days to respond to this.”

As a large gear drive designed for bulk material handling, the V-Class is primarily focused on only industries like mining and oil/gas. Implementing universally useful features on such a focused product first may raise a few brows when Rexnord had other lines they could have chosen as a

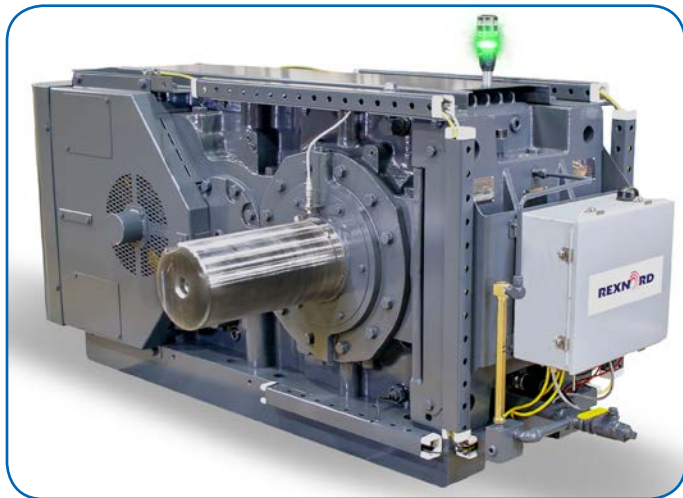

first candidate, but Miclot believes that these industries are where these features shine best. Most notably, gearmotors in mining and oil/gas applications can often have a decades-spanning lifetime, but regularly require maintenance to remain operational, which makes downtime a major issue for end users in these fields. Preventive maintenance can go a long way to alleviating that issue by reducing the strain on maintenance crews and improving uptime.

While the V-Class is somewhat limited in the markets it can reach, Rexnord will doubtless be rolling IoT functionality across more gearmotor lines in the months to come. And what has seen more widespread implementation is a QR code system that Rexnord has updated their entire portfolio of geared products with.

With a single scan of the QR code with a phone, end users can view everything from installation and troubleshooting instructions for their specific product to the warranty status on your specific gearmotor. Most importantly, the QR code only produces information directly relevant for the product it’s attached to. It does all the website searching for you.

QR codes also allow end users to set maintenance schedules for their gearmotors. Rexnord allows customers to sign up for maintenance reminders with a flexible system that allows the end user to input their preferred schedules and can accommodate for multiple schedules for different gearmotors.

Between both products, Rexnord is positioning themselves alongside numerous other companies to capitalize on the Internet of Things’ ever-increasing prevalence, taking advantage of the numerous ways the new field of technology allows them to push old metrics to new heights.

Framo Morat

DESIGNING FOR SPACE-CRITICAL APPLICATIONS

Framo Morat has recently come out with new hub-type planetary gearboxes laser-focused to fill space-critical applications that also feature high radial loads. To accomplish this, Framo Morat has made their gearbox as compact as possible. They’ve also managed to design the gearboxes to have solid bearing support without relying on tapered roller bearings in a bid towards cost-effectiveness.

The new gearboxes are designed with AGVs and warehouse shuttle drives integrated in wheel hubs or as timing belt drives in particular. That might sound like an incredibly narrow focus almost more worthy of custom designs upon customer request instead of a regular line of gearboxes, but according to Wolfgang Sühling, head of development at Framo Morat, it’s worth it.

“Thanks to e-commerce, the automatic warehouse industry generates a rapidly growing demand for compact wheel drives with high radial loads,” Sühling said. “The quantities justify tailored designs based on standard components which allows us to offer superior cost, size and load performance.”

Sühling believes online shopping will continue to grow, and in doing so, the industry will drive the production of AGVs up. And when it does, Framo Morat will already be in position to capitalize on it. **PTE**

For more information:

Baldor
Phone: (479) 646-4711
www.baldor.com

Brother International Corporation
Phone: (866) 523-6283
www.brother-usa.com

Framo Morat, Inc.
Phone: (505) 359-2949
us.framo-morat.com

Lenze Americas
Phone: (508) 278-9100
www.lenze.com

Parker Hannifin Americas
Phone: (800) 272-7537
www.parker.com

Rexnord
Phone: (414) 643-3000
www.rexnord.com

SEW-Eurodrive, Inc.
Phone: (864) 439-8792
www.seweurodrive.com

Siemens Industry, Inc.
Phone: (770) 871-3800
usa.siemens.com/gearmotors

For Related Articles Search

gearmotors

at www.powertransmission.com

Escaping Orbit: Orbitless Drives Develop New Alternative to Planetary Gearboxes

Though not directly involved with the purchasing of gearmotors, something your gearmotor manufacturer in turn might be looking at in the future is the Orbitless Drive, a new gearhead design being licensed by Orbitless Drives.

The Orbitless design is the brainchild of Leo Stocco, CTO of Orbitless Drives and robotics expert. The gearhead is a modified take on the standard planetary gearset. Namely, the design calls for removing the ring gear and replacing it with a second carrier attached to the planet gears with a second shaft.

The Orbitless gearhead is designed to be a general purpose tool with benefits across numerous industries from medical to aerospace to automotive and to work with all sizes of motors. As Orbitless Drives' CEO, Robert Eisses, put it, it's not designed to be a product. It's a platform.

"If you look at our customer base, they deal in multiple markets," Eisses said. "So anywhere from automotive to aeronautical to medical devices to industrial to consumer products; each of them have a different angle in terms of how they're addressing that market, whether it's cost or precision or whatever, and our technology applies to all of them to make their specific products in each of those markets better."

The laundry list of improvements over a standard planetary gearset is impressive: lower backlash, less friction, higher efficiency, lower pitch velocity, lower bearing velocity, relaxed assembly criteria, simpler construction, a wide range of applicable ratio configurations, functionality in both single and multi-stage applications and more.

A key benefit that contributes to the design's versatility is its resizability. According to Stocco, the Orbitless design dodges many of the issues planetary gears can run into when resizing, making it much easier to repurpose for different sized applications than planetary designs. The Orbitless gearhead's simpler design makes it easier to miniaturize compared to a planetary gearset, and removing the ring gear sidesteps potential difficulties that arise from the need to

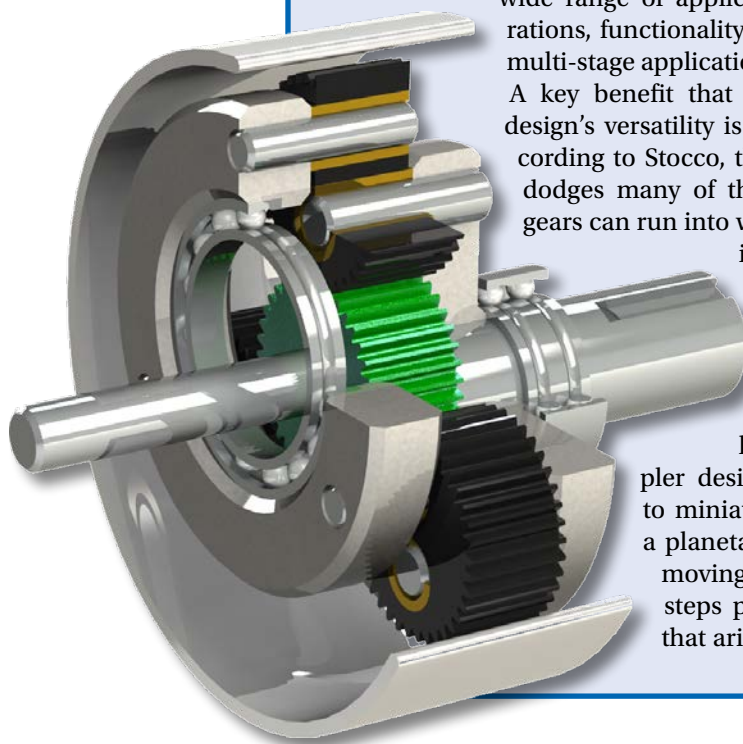

have such a large gear around the full set when the design is upscaled. And an additional option the Orbitless gear design supports over a planetary gearset is plastic gearing, particularly during resizing.

“The problem is when you make a ring [gear] small, it’s very thin and it easily deforms,” Stocco said. “Well when it deforms, the efficiency suffers dramatically. So if you make everything out of plastic, it’s hard to maintain the efficiency in a planetary gear where you can make the case and everything of an Orbitless out of plastic because they only have pinions which don’t deform so much.”

But because of the similarity in design, while an Orbitless gearhead may be less complicated than a planetary, it carries many of the same fundamental design principles. Many of the advances the industry has made in planetary gearing also apply to the Orbitless design, and much of the expertise a manufacturer may have built up designing planetary gearsets is still applicable when working with this new gear design.

“Because the parts are fundamentally equivalent to what’s been done for such a long time, you get to leverage all the advancements that have been made in tooth geometry and all the things that are being done in a planetary to make it more efficient,” Stocco said. “Well you don’t have to throw that away and start all over because it’s not so far different. You can use most of those techniques.”

In addition, the Orbitless gearhead design offers various benefits that would be appealing for different applications on both ends of the size spectrum.

According to Stocco, the Orbitless design is easy to manufacture, as well, requiring less expertise than a full planetary gearset.

“Anyone that is capable of manufacturing a planetary gear, it’s actually easier...the technology behind internal gears is unnecessary and everything else you’re already doing is all you need to do to implement it,” Stocco said.

And the goal for Orbitless is to get others to implement it. Rather than selling their own gearheads to end customers to attach onto an individual motor, they’re marketing them to gear and gearmotor manufacturers as a licensed component for the complete package before it goes to market. And to meet that end, the company has made sure their product is both simple and malleable in its implementation. The ways an Orbitless Drive can be utilized are as numerous and varied as the planetary design it’s derived from, with each configuration having

its own strengths to shine in specific industries or applications.

Considering the newness of the design, Stocco also believes that there may be additional, unexplored configurations as well, but any new possibilities Orbitless technology could open are only just starting to be explored. The patent pending Orbitless Drive was conceived only a few years ago, and the company only started working with customers in the past year to validate its efficiency and other properties. Its exact place in the industry has yet to be seen, as does how widespread the technology will become.

But whether the Orbitless Drive becomes a mainstay addition to the gearmotor manufacturer’s toolbox or a more specialized one, it remains a new and exciting tool in an industry that hasn’t seen an attempted reinvention of the wheel in some time.

Eisses, however, believes that Orbitless Drives’ design is in step with the times and will lend itself well to the ever-growing robotics and automation industries, which are always hungry for efficient, compact and portable designs, and the direction automotive is going around eMobility, which will require more efficient and quieter gears than ever. Stocco, who has a background in robotics himself, has also experienced more enthusiasm than he initially expected in the industry.

“The gear experts that we’ve been talking to have been surprisingly open-minded about accepting something that really changes the way that they potentially can operate,” Stocco said. “Up until now, there’s been two options that you compare between when you’re deciding how to implement a gear, and now we’re showing up with a third one. I was expecting more resistance than we’ve gotten from it. People were really quite excited to have a new tool in their toolbox in order to try to solve the problems that they get day to day.”

And if that enthusiasm is anything to measure by, you might want to keep an eye on the Orbitless gearhead’s progress in the industry — you may very well see it in a future gearmotor you purchase! **PTE**

For more information:

Orbitless Drives
Phone: (604) 724-3719
www.orbitless.com

U.S. Wind Power Blowing Hot as New Installations Flourish

Jack McGuinn, Senior Editor

Remember the U.S. wind energy revolution?

For most wannabe players at the time, the “revolution” started and ended without them. In a rather brief timespan most U.S.-based manufacturers discovered that the playing field was not a level one. Before long, the wind industry consolidated around four intimidating competitors — GE/Alstom, Siemens/Gamesa, MHI/ Vestas and Nordex/Acciona.

But guess what? Wind installations — both land- and off-shore-based — are popping up in various sectors of the country like dandelions.

Check out these numbers from the American Wind Energy Association’s (AWEA)’s 2017 annual report:

- As of January 2017, the U.S. nameplate generating capacity for wind power — 82,183 megawatts (MW) — is exceeded only by China and the European Union.
- The U.S. wind manufacturing sector consists of more than 500 manufacturing facilities spread across 41 states, producing the more than 8,000 components that comprise a typical wind turbine.
- In 2016, the U.S. wind energy supply chain included eight utility-scale blade facilities, nine tower facilities, and four turbine nacelle assembly facilities, all spread across 14 states.
- Ninety-five% of the wind power capacity installed in the U.S. during 2016 used a turbine manufacturer with at least one U.S. manufacturing facility.
- Major manufacturing facilities have the capability to produce approximately 11,700 MW of turbine nacelles, more than 11,000 individual blades, and more than 3,150 towers annually.

2017 Wind Project Installations:

- The U.S. wind industry installed 2,000 MW of wind capacity during the first quarter, the strongest first quarter for installations since 2009 and the second strongest first quarter ever. Installation activity was stronger than the first three quarters of 2016 combined.
- There are now 41 states with utility-scale wind projects. North Carolina commissioned the 208 MW Amazon Wind Farm US East, with all wind output contracted to Amazon Web Services. This is only the second wind project to be built in the Southeast and the first to be built in 12 years.
- Twelve states commissioned a total of 25 projects during the first quarter. Texas led with 724 MW, followed by Kansas (481 MW), New Mexico (242 MW), North Carolina (208 MW), and Michigan (149 MW).
- There are now 84,143 MW of installed wind capacity in the United States, with more than 53,000 wind turbines operating in 41 states, plus Guam and Puerto Rico.
- GE Renewable Energy, Siemens, and Vestas captured a combined 88% of the U.S. wind turbine market during the first quarter.

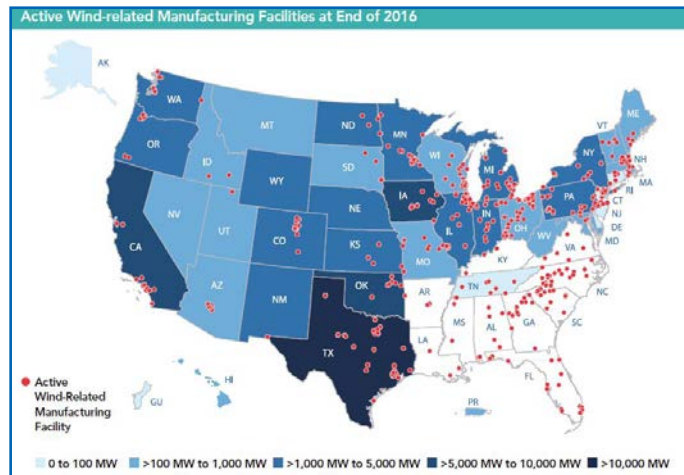

Courtesy AWEA.

Wind Capacity Under Construction or in Advanced Development

- There are now 9,025 MW under construction and 11,952 MW in advanced development, a combined 20,977 MW of wind capacity, the highest level since AWEA began tracking both categories at the beginning of 2016.
- Project developers announced 4,466 MW in combined new activity during the first quarter, including 668 MW in new construction announcements and 3,798 MW in new advanced development announcements.
- 42% of combined activity is located in Texas and the Plains states, with an additional 37% located in the Midwest.

(Source: AWEA)

Looking to get some perspective regarding the above numbers, we put some questions to three individuals intimately familiar with renewable energy — **Peter L. Kelley**, vice president, public affairs, American Wind Energy Association; **Jeff McLaughlin**, P.E., Machine Builder Specialists; and **Bruce Neumiller**, CEO, Gearbox Express.

Can you point to what in the last two years has been the most significant manufacturing/technological breakthrough for wind turbines?

PETER KELLEY (PK)

Digitally managed wind farms that operate an entire array of turbines as a unit, and that save money through condition monitoring and predictive maintenance, are the way of the future and are helping further drive down costs.



JEFF MCLAUGHLIN (JM)

Manufacturing: 1) “Repowering” of wind turbines has significantly changed the dynamic for service and repairs. 2) The commissioning of off-shore wind turbines in the U.S. From a technological perspective, the life prognostication of bearings and gears has changed O&M (operations and maintenance) from reactive to proactive, and the success of more “direct drive” (or gearless) turbines is a prelude to where the industry is heading.



BRUCE NEUMILLER (BN)

The improvement in technology comes from a better understanding of wind conditions and of operational parameters of wind turbines in North America. Better monitoring of the machines in recent years has led to better technology.



What has impacted the wind turbine industry most over the past year or so?

PK.: Stable federal policy has enabled bumper crops of new wind farms across the most wind-rich states, driving penetration in Iowa for instance close to 40% wind, and over 10% in 14 states. That in turn has brought further cost savings through economies of scale and U.S. manufacturing.

JM.: Consolidation of the wind turbine OEMs, including – GE/Alstom, Siemens/Gamesa, MHI/ Vestas and Nordex/Acciona.

BN.: Repower definitely gets the gold award for this. It has put the entire industry in turmoil as owners try to figure out whether or not they are going to repower. It also has put strain on aftermarket companies, as the owners were essentially “on hold” for about six months while trying to determine their course of action.

Can you explain why there are fewer wind installations in the southeastern U.S. and, to a lesser extent, the midwestern and eastern states?

PK.: The wind resource at 80 meters is lower than in the rest of the country, partly because of tree cover as well as how the wind blows across the country. At 110 meters, though (where turbines are now reaching), we will see more wind farms there like the new one in North Carolina that serves Amazon Web Services.

JM.: Some states (Texas and Iowa to name two) have encouraged more renewables – especially wind energy.

BN.: This is primarily driven by the wind conditions. As the technology improves and allows for capturing enough wind in low wind conditions, we will see more development.

How vertical is the industry becoming re: gears, gearboxes, bearings, nacelles, rotors, etc.? Can even a good-size independent job shop ever hope to land some of that work? Or when the smoke clears will only GE, Vestas and Siemens be left standing?

PK.: There are 8,000 parts in a wind turbine, so there is a robust supply chain including over 500 U.S. factories with 25,000 workers as of the start of 2017. The manufacturers you name do have the lion’s share of the U.S. market, but other manufacturers are working to re-enter the market and expand their share.

JM.: The turbine companies for the most part have been “systems or component integrators,” purchasing gearboxes, generators, towers and even blades, but usually keeping their focus on certain components like power electronics. This has ebbed back and forth over the past 20 years with little net change. Much sourcing by the turbine OEMs has moved to the Orient in the past 10 years, including gearboxes.

BN.: The industry is not vertical and I actually believe it will become less vertical as companies focus on what their core competencies really are. That being said, mergers and acquisitions are trending (e.g., Nordex/Acciona, Siemens/Gamesa, ZF/Bosch Rexroth). Scale is necessary to compete, in terms of access to the best technology and lower selling, general and administrative expenses.

Most OEM turbine gearboxes intended for the U.S. market are made in Asia and Europe. Why is that? And, while the numbers are better for U.S. wind gearbox repair, that begs the question: if we can fix them here, why can’t we make them here?

PK.: ZF Hanson in Georgia and Winergy in Illinois are examples of U.S. gearbox makers.

JM.: All components can be made in the U.S. with the specified quality. However, the casting suppliers (for housings) that could produce the quantities of castings needed are out of business. Most OEM gearboxes were originally sourced in Europe (where the gearboxes were designed) but production is now centered in China. The U.S. supply base for castings, bearings, gears and gear raw material has been hit hard.

BN.: We can and do make them here, but the turbine OEMs are faced with pressures to keep costs as low as possible; hence looking to source gearboxes in Asia or

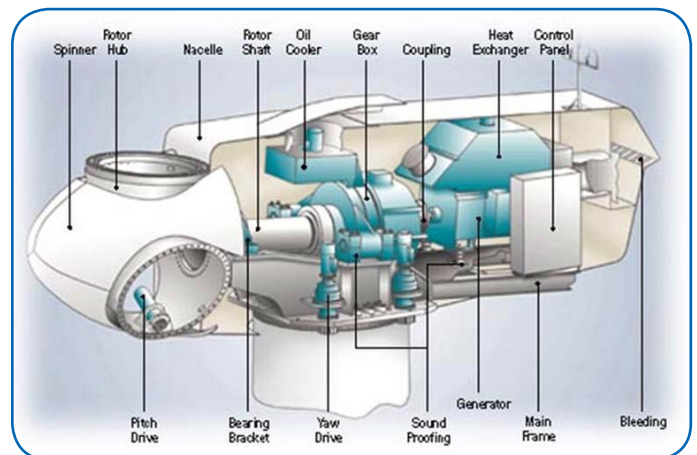

Courtesy AWEA.



Europe. It's essential to look at the entire lifespan of the gearbox to determine cost savings.

As installations seem to be proliferating, the need for their maintenance and repair grows. Is that part of the industry demand being met?

PK.: Yes, through a combination of OEMs, in-house maintenance by owner-operators, and third-party shops such as Shermco.

JM.: The service provider industry is growing rapidly and the number of jobs created by this market segment has been outstanding!

BN.: Today most needs are being met. But, come 2025 – when the installed base has aged even more – the services market will also “proliferate” in size.

How if at all has global warming/climate change affected the wind energy industry? Is it “good for business?”

PK.: We focus on the economics which are excellent these days, as long-term contracts for wind out-compete even natural gas prices expected in the near future. Public health and environmental savings are real too; the Harvard School of Public Health estimated over \$7 billion a year in avoided health care and hospital costs – just from SOX and NOX emissions avoided.

JM.: Renewable energy sources – including wind and solar – are of importance to everyone for numerous reasons, including climate change.

BN.: The focus on climate change has opened many doors to discuss a variety of energy sources, to fund exploring new and improved technology for harnessing wind energy, and to work together to find solutions. Wind energy is no longer seen as “alternative,” thanks to the increased focus.

Have there been engineering/logistical improvements that facilitate on-site maintenance and repair?

JM.: Yes, such innovations as the self-climbing crane and material handling devices that can easily be transported uptower have greatly facilitated this and the savings to the owner/operators from this approach has been tremendous!

BN.: While some companies have really focused on up-tower service, we are now starting to see gearboxes that have had \$20–40,000 or more worth of up-tower work done in the recent past, come in our door. The owners are questioning what sounded initially like a good idea. Was it worth it?

And there also have been advancements in crane technology, and we expect the trend to continue. Traditional cranes are expensive; newer, self-hoisting systems can do the job for half the cost. As acceptance in the industry increases, up-front capital cost will reduce and the in-and-out cost could be as low at \$50,000 to \$75,000.

Are “hybrid steel” gears impacting wind gearbox manufacture?

JM.: Wind turbine gears are high precision and have high load carrying capacity; they specified using European carburizing grade steels (Cr Ni Mo steels). These grades offer very high strength with the appropriate heat treatment.

The design direction of the gearbox OEMs has been to greater power density (lower cost) gearboxes, designing with the X-plus methodology that not only increases the bending strength capacity of the gears, but also increases the working pressure angle and significantly increases the forces on the bearings. There is a need for further engineering development with newer design approaches, such as “high contact ratio” and/or dual pressure angle (hypoid) types of gears, that could potentially reduce the forces on the bearings but still retaining the high bending strength.

How might 3-D printing be used in the wind power industry? Aside from 3-D’s impressive prototyping capabilities, are 3-D-printed production gears coming anytime soon?

JM.: The strength requirements are demanding and the 3-D print and additive manufacturing processes requires further development.

BN.: Gearing for wind energy application is among, if not the most, demanding in existence, requiring absolute precision and it’s too soon to say if any 3-D-printed production will be able to meet those extremely high standards.

Acknowledging the usual underlying causes (design, lubrication, etc.), is bearings failure still the top reason for premature breakdowns – or something else?

JM.: Bearing failures are predominant (see response above on X-plus gears).

BN.: White-etch-area (WEA) axial cracking of high-speed and intermediate bearings is the single largest observed failure in young wind turbine gearboxes. It took the entire wind industry by surprise, and no turbine/gearbox model is immune to it. After significant public and private researching – most notably NREL GRC (Gearbox Reliability Collaborative) and Argonne National Laboratory – there appears to largely be consensus on its causes and what can be done to prevent it.

Beyond WEA cracking, improper bearing setting and or material impurities can lead to infant mortality and generally manifest as a failure within five years.

Aside from accessibility, is gearbox lubrication more complex in wind turbine applications than in other extreme conditions applications? Are, for example, turbine gearbox lubrication requirements materially different from a gearbox/paper mill application?



Photo courtesy Brad Romano.

JM.: The gearbox lubrication system is extremely important, providing the following; a) an oil film to separate metal surfaces from contacting each other; b) reducing sliding friction; c) stabilizing the temperature of the gearbox (gears and bearings); d) facilitating the removal of wear particles to the filter; and e) inhibiting rust and corrosion.

BN.: Lubrication is the lifeblood of any gearbox application. Having said that, gearboxes used in wind turbines tend to contaminate more easily due to the labyrinth seal technology used, making filtration even more important.

Are synthetic lubricants being used more with any regularity over non-synthetics?

JM.: Synthetic lubricants have been in extensive use in wind turbines since the 1980s.

BN.: Most, if not all, wind gearboxes are running synthetic lubricants. **PTE**

For more information:

Peter L. Kelley
Vice President, Public Affairs
American Wind Energy Association
1501 M St. NW, Suite 1000
Washington, DC 20005
pkelley@awea.org
www.awea.org

Bruce Neumiller
CEO, Gearbox Express
155 West Dewey Drive
Mukwonago, WI
Phone: (262) 378-4303
Gearboxexpress.com

Jeff McLaughlin, PE
Machine Building Specialists, LLC
Phone (office): (920) 684-0585
Cell: (920) 901-7139
www.facebook.com/MachineBuildingSpecialistsLLC

For Related Articles Search

wind energy

at www.powertransmission.com

Guide to Proper Bearing Lubricating Procedures

Klüber Lubrication

Understanding proper bearing lubrication procedures is critical to ensuring long-term, trouble-free performance. Klüber Lubrication has prepared this explanation as a general guide. If a more detailed explanation is required, please contact your nearest Klüber Lubrication representative or the manufacturer of the lubricant you are using.

Although these procedures apply specifically to grease lubricated bearings, the information contained herein may be useful in other similar applications.

Before you lubricate any bearing, it is very important to select the proper lubricant based on the specific requirements of the application. Factors such as speed, type and size of bearing, temperature (ambient and bearing) and surrounding media have to be considered carefully to select a lubricant which will provide the desired service. Klüber Lubrication representatives are carefully trained to assist in selecting the best product to use.

What are the Benefits?

The main objective in using these procedures is to produce a system where the lubricant is operating at its most efficient state. This means that the lubricant is set correctly in the bearing using the proper quantity of product and that the bearing is operating at the lowest possible steady-state operating temperature. This provides the necessary situation for long life, high-speed running without excessive heat generation. Keep in mind that excessive bearing temperatures will decrease both lubricant life as well as system operating precision.

The Importance of Following Procedures

The procedure followed in applying a lubricant can be as important as the lubricant selected. Three areas which are of particular importance in the application of a lubricant are:

- Bearing Cleaning
- Lubricant Fill Quality
- Bearing Run-In

When Do They Become Important?

High-speed precision machine tool spindle bearings that are grease lubricated (without the availability of relubrication) must follow these specific procedures in order to operate successfully. Those applications where the operating parameters have become critical (such as bearings and/or lubricants that are operating close to their rated speeds or applications that are lubricated-for-life) may also benefit from these procedures. Other less critical applications may also benefit from these procedures, although it is possible to operate successfully without them. The apparent benefits become clear as the bearing speed exceeds $500,000 nD_m$ (n = bearing rpm, D_m = mean diameter of bearing in mm).

You may find from experience that some applications require more attention than others or that some applications may allow some steps to be eliminated. It is, therefore, important that you fully document and review each application procedure so that you can achieve future benefits from the information you have accumulated.



Figure 1 Before you lubricate any bearing, it is very important to select the proper lubricant based on the specific requirements of the application.

Part 1: Cleaning

The removal of any existing oils, greases and anti-corrosion coatings increases in importance as the operating life and reliability of the application becomes more and more critical. The wetting of the contact surface by the lubricating film will be enhanced by a clean contact surface. Removal of these oils, greases and coatings will also eliminate any potential incompatibilities that may exist between these products and the subject lubricant. It is always advisable to remove these materials prior to applying silicone or perfluorinated-based products.

Existing surface coatings can act as separating agents, preventing the applied grease from wetting the bearing balls and races properly. For applications that operate in the high speed range ($nDm > 800,000$ or $n/ng^* > 0.8$), or when a specialty lubricant is being used, a clean, dry surface may be critical to ensure the proper adhesion between the grease thickener matrix and the bearing surfaces.

Many bearing companies provide their products pre-coated with an oil film and/or anticorrosion coating. If this coating has both a micro-thickness and is compatible with the chosen lubricant, then a pre-cleaning may not be necessary. It is important to discuss this situation with the subject bearing and lubricant supplier.

Use of a non-residual solvent for the cleaning of bearing surfaces provides the optimum lubrication condition. Prior to selecting a suitable industrial solvent, it is important to refer to any applicable federal, state, local or global regulations regarding their restrictions or proper use.

The most efficient non-residual solvents were CFC-113 (Freon® TF) and methyl chloroform (1,1,1 Trichloroethane). However, restrictions on ozone depleting chemicals prohibit the use of these solvent types. In this case, the best allowable non-residual solvent should be used.

The application criteria, along with the degree of contamination, will determine the extent of cleaning and whether multiple cleanings or ultrasonic cleaning is necessary.

As the cleaned parts dry, they become prone to atmospheric corrosion. If immediate lubrication is not possible, the parts should be coated with a dispersion of the intended lubricant prior to storage. Even if the bearings are immediately lubricated, the “non-lubricated” surfaces are still prone to corrosion. Therefore it is advisable to apply a light anti-corrosion coating to these bearing surfaces after lubrication.

* n = bearing rpm, ng = speed rating of bearing using grease (rpm)

Part 2: Ensuring Proper Fill Quantity

The proper fill quantity is important to ensure that all contact surfaces are provided with a suitable lubricating film over the designed operating life. Over-lubrication can be as detrimental as under-lubrication. With over-lubrication, there is an increase in the internal friction of the component as excess lubricant is moved through the free space. This results in increased heat generation and, therefore, a shorter application operating life. With under-lubrication, a boundary lubrication condition will occur, as all contact surfaces are not supplied with the proper quantity of lubricant. This condition may lead to wear and/or lubrication starvation resulting in shorter operating life.

The correct lubricant quantity is determined by the design, operating speeds, reservoir volume and the extent of sealing or shielding found in the application. The objective of the lubricant fill quantity is to provide the contact surfaces with a consistent lubricating film thick enough to prevent metal-to-metal contact and support full fluid film lubrication.

Fill quantity becomes of particular interest when the application requires the use of grease lubricated bearings. The bearing modified speed factor ($ka \cdot nDm$ – see table below for correction factors) for the application becomes an important factor in determining the proper grease quantity.

When the lubricating film is setting up during run-in excess lubricant will be expelled from the contact surface area. It is important that this excess lubricant is not restricted from leaving the contact surface area so as not to increase the internal friction of the system. When the application is sealed or shielded (no exit path for the excess lubricant), it becomes especially important to choose the proper fill quantity.

By providing a cavity outside of the contact area greater than the static free space of the bearing, there is enough of an area available for the excess lubricant. This cavity will also provide a lubricant reservoir that may continually feed the lubrication point, through capillary action, during operation (Figure 2). This cavity must be large enough to be able to contain the total volume of excess lubricant, but small enough to

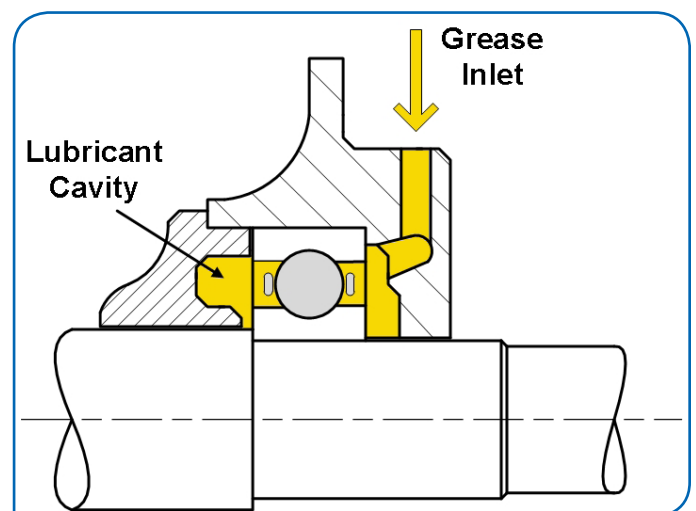

Figure 2 By providing a cavity outside of the contact area greater than the static free space of the bearing, there is enough of an area available for the excess lubricant. This cavity will also provide a lubricant reservoir that may continually feed the lubrication point, through capillary action, during operation.

ensure the proper capillary action. The availability of a proper grease reservoir can aid in sealing and extend the overall lubricant life.

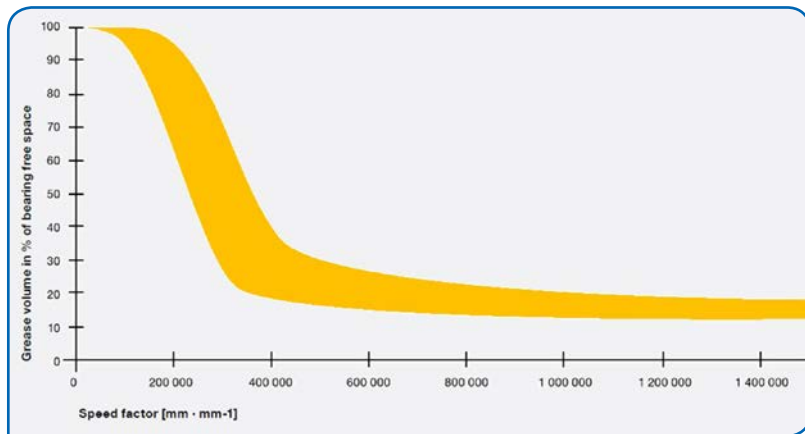

Figure 3 Most bearing and grease manufacturers recommend the following rules of thumb for bearing fill quantity. The area marked in yellow indicates the grease fill as a function of the speed factor.

Part 3: Determining Bearing Free Space

The proper fill quantity of a grease lubricated bearing is often specified as a percentage of the bearing’s free space. It is, therefore, important that the bearing’s free space is accurately determined. Some of the available methods for determining a bearing’s free space are described below. These various methods are listed according to both accuracy of results as well as simplicity, with the simplest and most accurate method presented first.

Published Engineering Data

Many bearing manufacturers have already determined the free space for a number of their catalog bearings (Figure 4). Because each manufacturer maintains design information on his bearings, a simple phone call to the engineering department of the bearing manufacturer will result in the most accurate value for a specific bearing’s free space. Unfortunately, due to the large number of catalog bearings available, coupled with the relatively minor importance of this information, some bearing manufacturers do not have ready access to every bearing’s free space.

Published Reference Charts

Many major bearing manufacturers have developed generalized bearing free space reference charts. These charts help the user to calculate a specific bearing’s free space based on the bearing’s design configuration and inner diameter. Compiling this information for all bearing configurations makes these charts efficient reference tools. However, one must keep in mind that the free space information presented on these charts is generalized. Modifications to the bearing, such as the addition of shields or seals, may change the actual free space. In addition, due to differences in internal design configurations, information from one manufacturer’s chart may not always be transferred to another manufacturer’s product.

Rule of Thumb Equation

Probably the most complex method to determine a bearing’s fill quantity is the Rule of Thumb equation. However, this method is just that, a ‘rule of thumb’, and has limited accuracy. Keep in mind that some applications, such as those with available lubricant cavities or those operating with low speed factors, may not require an extremely accurate measurement of the bearing’s free space. In these cases, the following equation should be sufficient.

$$Free\ Space\ (cc's) = \frac{w(D^2 - d^2) - 74251W_b}{1273.24}$$

- w = bearing width (mm)
- D = bearing OD (mm)
- d = bearing ID (mm)
- W_b = bearing weight (lbs.)

Part 4: Run-In Procedures

A proper run-in procedure is vital to the performance of the bearing and lubricant in applications where high speeds, fill quantities and certain preloads are critical. That’s because during the run-in process, the initial grease fill is evenly distributed around the bearing elements. A grease collar is formed to optimize the release of the base oil in a way that the friction surfaces are wetted with just the right oil quantity. As a result, the rolling elements and the cage don’t entrain the entire lubricating grease, but just the required amount of oil.



Figure 4 Many bearing manufacturers have already determined the free space for a number of their catalog bearings.

If the necessary run-in is omitted, excessive operating temperatures and/or an over-lubrication condition will result. It is best to consult with the lubricant manufacturer if you have any questions in this area or if your specific application does not reach a stable equilibrium operating temperature after it has been run-in.

A proper run-in procedure:

- Expels the excess grease found in the system
- Orients the lubricating film on each contact surface
- Creates a grease collar to deliver oil to the contact zone

- Establishes a low equilibrium operating temperature
- Achieves a sealed-for-life lubrication condition

Considerations for Run-in Procedures

Most lubricating greases can benefit from the displacement of excess grease, but not all lubricating greases will orient themselves on the bearing surface. There are several factors to consider:

- * Certain soap-based greases are fibrous in texture and will set up an oriented matrix on the surface of the bearing raceway.
- * A benefit to using a polyurea thickened grease is that it does not have this fibrous texture and the run-in procedure can either be reduced or eliminated.
- * Follow recommended run-in procedures. Although there are alternatives for applications where speed or temperature cannot be varied or monitored, it is ideal to have some control of these parameters. Each bearing manufacturer has a specific run-in procedure that may differ from the examples below. Always check with your specific equipment/bearing OEM prior to performing a run-in.

Important Note:

To achieve the full benefits from these procedures, bearings should be run in the same direction in which they will operate. It is also advisable to perform the run-in at the actual application site, because the motion associated with shipping/handling and assembly of the bearings may affect the results of the controlled run-in.

Six Run-in Procedure Steps

1. Start at a reasonable low speed, typically 20% of the maximum operating speed. Closely monitor the temperature of the bearings.
2. Increase speed incrementally when a stable temperature is reached.
3. Continue the incremental increases in speed as described. If a rapid temperature increase occurs, stop the run-in process. This temperature spike indicates a pre-load due to thermal expansion. Maximum bearing temperatures should not exceed 70°C (158°F). Temperatures in excess of 70°C will cause excessive bearing pre-loads and possible permanent grease or bearing damage.

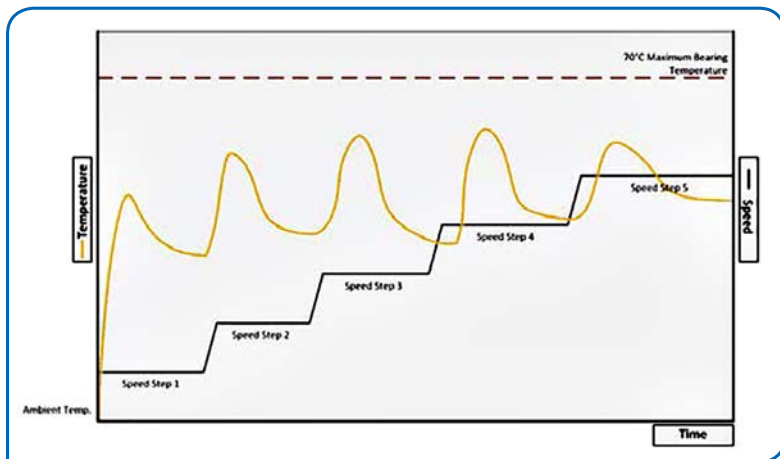

Figure 5 Variable-speed run-in procedure: Increase speed incrementally when a stable temperature is reached.

4. Allow the system to cool to room temperature.
5. Restart the procedure at the last speed prior to the temperature spike.
6. Continue reading the above cycle until an equilibrium temperature is reached at the maximum operating speed of the application. The ideal equilibrium operating temperature is approximately 35°C to 40°C (95°F to 105°F).

Alternative Run-in Procedure

When speed cannot be varied, run-in at constant speed is still possible. In this operation, the bearing should run at full speed for about 30 seconds. After stopping, the heat in the bearing dissipates. In this way, a dangerous temperature rise is prevented. The non-running time depends on the various design factors, but it should be at least five times greater than the running time. This interval should be repeated until the bearing temperature becomes constant.

Part 5: Filling a Bearing

High precision rolling bearings should always be lubricated with clean, fresh grease. It is also important that they be lubricated in a clean, dry environment so as to minimize the possibility of moisture or debris damaging the bearing.

Assuming that you have already determined the specific lubricant to be used, the first step is to determine the proper amount to be introduced into the bearing (refer to the section on Proper Fill Quantity).

The easiest way to measure grease quantity is to repack the grease into a graduated syringe. With this tool, the quantity can be monitored easily. Different size syringes with different tip configurations are commercially available. A fine tip on the syringe can increase the accuracy of where the grease is placed in the bearings as well.

A grease gun can be used for larger bearings, where the fill quantity is large. However, if a grease gun is used, it must be calibrated first. The easiest way is to weigh the amount of grease that the gun puts out for each complete stroke. Because most grease guns do not expel consistent amounts per stroke, an average measurement should be used. For example pump out 10 strokes of grease and divide the total weight by 10 to determine the average quantity per individual stroke.

$$\text{Volume (cm}^3\text{)} = \frac{\text{Weight (grams)}}{\text{Density (grams/cm}^3\text{)}}$$

Because most bearings are shipped with a corrosion protective coating, you must verify whether or not this coating has to be removed prior to lubrication. These coatings are typically miscible with mineral oil-based products and, therefore, are not required to be removed. However, it is imperative to remove these coatings when using silicone or perfluorinated-based products. In addition, high-speed and critical applications may also require the removal of these anti-corrosion coatings (refer to previous section on Cleaning).

If the bearing is already mounted in a housing (i.e. pillow block bearings), the grease should be introduced slowly into the grease fitting while ro-

tating the bearing without load. If the bearing is in its free state, an equal amount of product should be introduced into the pockets between the rolling elements (Note: Divide the fill quantity by the number of rolling elements). The bearing should then be rotated without load so as to distribute the grease throughout the raceways. For precision bearings or pre-loaded bearings running in high speed applications, bearing run-in may be required (refer to previous section on Run-In Procedures).



Figure 6 Grease guns can be filled manually or can be used in conjunction with a grease cartridge. Grease cartridges can allow for simple, clean relubrication with little waste.

Once a bearing has been lubricated it should be put into service. If the lubricated bearing is to be stored, it should be wrapped in specially treated anti-corrosion paper (VCI paper) and placed in a clean, dry area.

Part 6: How to Use a Grease Gun

Grease guns can be filled manually or can be used in conjunction with a grease cartridge. Grease cartridges can allow for simple, clean relubrication with little waste. Grease cartridges typically contain 400 grams (14 ounces) of grease.

Operating Instructions

1. Pull out the grease gun piston until it is fully retracted. The automatic clamping device will lock into place.
2. Unscrew the top portion of the grease gun.
3. Remove the cap/foil cover from the grease cartridge.
4. Remove (cut with knife) or remove plastic cap of the opposite end of the cartridge.
5. Insert the cartridge into the grease gun.
6. Screw the top portion of the grease gun back on.
7. Depress the automatic clamping device and press the piston into the gun.
8. Push on the ventilation relief valve to allow for the escape of any entrapped air.

Part 7: Sampling Procedure for Grease Analysis

Monitoring grease condition is an important step in maintaining and tracking equipment reliability. It can detect lubricant break-down and aid in identifying potential problems before they occur. Corrective actions can be taken before other signs of deterioration begin to show, such as

increases in operating temperatures, noise, and vibrations. By tracking the condition of grease in an application, it can provide important information on the quality of the grease, how it is performing and help adjust relubrication intervals.

The following is a general guideline to follow when removing samples from a piece of equipment or component to increase the accuracy of the analysis. *Caution: Personal care must be taken when sampling from equipment. It is up to the user to determine the safest way to obtain a sample.*

Sampling Containers

Ensure the material of the container will not interact with the material being sampled. Crushproof plastic or glass bottles are typically acceptable and preferred. Plastic bags can be used, but may interfere with analysis of grease consistency. Rags and other absorbent materials should be avoided. The size of the container should be selected to ensure sufficient sample quantity so that all of the intended analyses can be completed.

Cleanliness

To minimize potential contamination of a grease sample, the following precautions should be followed:

- Gloves should be worn for personal protection and to minimize sample contamination.
- Visually inspect and clean sampling containers and sampling equipment if needed.
- Clean the component to be sampled from dirt, dust and any other contaminants that may affect the results of the analysis.
- Once the sample is taken, the container should be capped or sealed to prevent leaking or further contamination.
- It is always good practice when shipping multiple samples to also seal each container in a separate airtight bag to prevent leakage and possible cross-contamination.

Sample Labeling

Proper labeling is of the utmost importance to ensure that the analysis is completed properly. Each component and piece of equipment should be given a unique identification for tracking and trending purposes. The samples should be taken one at a time and labeled immediately upon collection. As a minimum, the following information should be written on each sample bottle:

- Sample Date and Time – when the sample was physically taken from the component
- Equipment Description – brief summary of the facility and equipment, including the location, make, model, machine number, etc.
- Run time of the current grease
- Name of the baseline grease
- Contact information, including facility location and who took the sample and their own Ziploc bag for shipping to prevent leakage or cross contamination.

Once samples are properly contained and labelled, they should be adequately prepared for shipment to ensure that they arrive without damage. It is important to include the appropriate SDS with any grease shipment.

Part 8: Change-Over Procedure

This procedure pertains to changing grease types or changing from one lubricant manufacturer to another. It explains how to relubricate bearings using a new grease and expel the previous grease.

Initial Requirements

(These conditions must be met.)

- A. Verify that the bearing arrangement allows excess lubricant to be bled from the system. Bearing damage may result in sealed-for-life systems or systems with oil tight sealing arrangements.
- B. Verify that the new lubricant and the previous lubricant are fully compatible. Mixing two incompatible products may result in chemical or physical changes which will lead to improper lubrication. Contact the lubricant manufacturers to verify compatibility.
- C. Verify that the subject bearing is operating properly prior to switching products. Improper fits, clearances, bearing configurations or existing bearing damage cannot be corrected by changes in lubrication.
- D. Verify that the bearing operating condition can accept a 100% fill condition. This procedure should not be applied to bearings which are designed to operate with limited grease quantities. Excessive bearing operating temperature may result in these cases.

Procedure

- 1. While the bearing is running, slowly pump in the new grease until the excess grease being bled from the bearing changes in consistency or color. This waste grease should eventually look similar to the new product.
- 2. Repeat step 1 after one to two hours of operation or after the bearing has reached a steady-state operating condition.
- 3. Run the bearing for one week (only if the previous relubrication frequency was greater than one week) and relubricate using the normal relubrication procedure.
- 4. Relubricate more frequently during the first two relubrication periods.
- 5. Initiate testing (power consumption, amperage draw, relubrication frequency, etc.)

Part 9: Lubricant Storage and Shelf Life

Lubricants should always be stored in their original container, in a clean, cool, dry location. Once the container has been opened, the lubricant is subject to contamination by moisture, dirt, and airborne particles. Lubricants should also always be kept in their original container and not transferred into other containers. This process only invites contamination. Note that most lubrication companies provide a wide variety of packaging sizes for this simple reason. It is recommended that the quantity of lubricant that is purchased be close to the amount of product necessary to do the particular lubrication job. In too many cases, excess lubricant is improperly stored. This situation may lead to the use of contaminated product, or product that has surpassed its recommended shelf life.



Figure 8 Lubricants should always be stored in their original container, in a clean, cool, dry location. Once the container has been opened, the lubricant is subject to contamination by moisture, dirt, and airborne particles.



Figure 7 Tips for grease changeover procedures include cleaning grease fittings before lubrication, pumping slowly and applying new grease to a bearing that is turning.

Shelf Life

The shelf life of a lubricating grease is that period over which a lubricant can be stored without experiencing a significant change in properties. Shelf life will differ from product to product depending on the product's formulation, NLGI grade (for greases) and storage condition. Bearings which are pre-lubricated also have a shelf life. Assuming that the bearing lubricant was applied close to its manufactured date, the bearing/lubricant combination will have the same shelf life as the lubricant. If a lubricated bearing (or a piece of lubricated equipment) is to be stored for a period that exceeds that of the grease shelf life, the bearing should be periodically operated without load. This will help to keep the lubricant homogeneous. **PTE**

For more information:

Klüber Lubrication
Phone: (630) 647-4104
www.klueber.com

For Related Articles Search

lubrication 

at www.powertransmission.com



Nordex[®]
INCORPORATED

Over 32,000 standard components.
Buy online 24/7.

Nordex.com



Turner Uni-Drive
Manufacturers of Industrial Transmissions,
Speed Reducers & Gearboxes

www.turnerunidrive.com

Catalog Multi-speed

Custom Design

OEM Manufacturing

- **Standard catalog and custom engineered gearboxes**
- **1 HP to 1000 HP**
- **Gearbox repair**
- **Reverse Engineering**

Turner Uni-Drive Phone: 816-931-6001 | Toll Free Phone: 800-637-7736
3434 Terrace Street | Kansas City, MO 64111 Fax: 816-931-6055



B&R
MACHINE AND GEAR CORP

BRGEAR.COM

Precision Positioning

The Spinea cycloidal reducer offers superior precision and performance over harmonic flex splines.

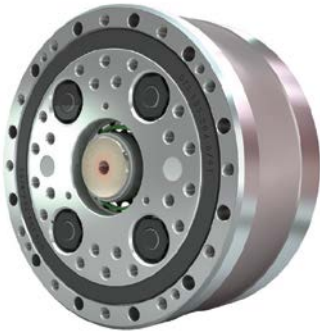

- Sizes from 50 - 140 mm
- Zero Backlash
- Higher Torque Density
- Higher Tilting Capacity
- Higher Torsional Rigidity

DIEQUA
Corporation

www.diequa.com

630-980-1133

Planetary Gearheads

The Sesame series offers a wide range of performance levels, configurations, and mounting options.



- Frame sizes from 42 - 220 mm
- Precision and economy models
- Round or square face mounting
- Ratios from 3:1 to 1000:1

DIEQUA
Corporation

www.diequa.com

630-980-1133

Cleveland Gear Stainless Steel Reducers... the Answer for Food & Beverage Applications



Built in USA

www.clevelandgear.com

Power Transmission Engineering online!

It's like your own professional superpower.

Stronger, faster and smarter than your average website, www.powertransmission.com offers everything you need to supercharge your engineering-oriented organization.

- Complete archive of articles on engineered components
- Directory of suppliers of gears, bearings, motors and other mechanical power transmission components
- Product and Industry News updated daily
- Exclusive online content in our e-mail newsletters
- The Bearings Blog
- Calendar of upcoming events
- Comprehensive search feature helps you find what you're looking for — *faster than a speeding bullet!*

www.powertransmission.com



A Model for Shear Degradation of Lithium Soap Grease at Ambient Temperature

Yuxin Zhoua, Rob Bosmana and Piet M. Lugt

In this paper the shear degradation of lithium 12-hydroxy stearate grease will be measured using an in-house-developed Couette aging machine. In this device the shear rate is well defined. The aging is related to the generated entropy density, as described in Rezasoltani and Khonsari's work (Tribology Letters, Vol. 56, No. 2, pp. 197–204, 2014 and Ref. 11). The rheological properties of the aged samples were evaluated using a parallel-plate rheometer. The results showed that there are two aging phases with different degradation rates, i.e. — a progressive degradation phase at the early stage, followed by a rather slow deterioration afterwards. Based on this observation an aging equation was formulated to describe the aging behavior of lithium-thickened grease. Atomic force microscopy results of the fresh and aged greases showed that the variation in thickener microstructure provides a good explanation for the lithium grease degradation mechanism; under shear, the original fibrous network is progressively destroyed and becomes fragmented, leading to the loss of consistency and a change in the rheological properties.

Nomenclature

\bar{F}	Average load per stroke inside the grease worker (N)
f	Frequency for the oscillatory test (Hz)
G'	Storage modulus (Pa)
G''	Loss modulus (Pa)
h	Gap height of the aging machine (m)
K	Coefficient of degradation
L	Average thickener fiber length (μm)
L_{piston}	Piston displacement for one full stroke of the grease worker (m)
m	Degradation exponent
R^2	Goodness of fit
R_a	Surface roughness of the measuring plates (center line average, μm)
R_i	Radius of the rotating bob (m)
R_o	Radius of the stable housing case (m)
S_g	Generated entropy-per-unit volume during aging ($J/\text{mm}^3 K$)
S_g	Entropy generation rate-per-unit-volume during aging ($J = \text{mm}^3 Ks$)
S_{gw}	Generated entropy-per-unit-volume inside the grease worker ($J = \text{mm}^3 K$)
S_{ps}	Generated entropy-per-unit-volume during pre-shear ($J = \text{mm}^3 K$)
T_{gw}	Ambient temperature of the grease worker (K)
T_{ps}	Temperature during pre-shear (K)
V_a	Grease volume inside the Couette aging rig (mm^3)
V_{gw}	Grease volume inside the grease worker (mm^3)
W_{gw}	Work applied inside the grease worker (J)
Y_∞	Second-stage rheological value after infinitely long aging
Y_i	Initial rheological value for fresh grease
$\dot{\gamma}_a$	Aging shear rate (s^{-1})
$\dot{\gamma}_{ps}$	Shear rate for pre-shear (s^{-1})
Δ	Cone penetration depth (0.1 mm)
η_0	Zero shear rate viscosity (Pa·s)
η_∞	Grease viscosity after infinitely long aging (Pa·s)
η_b	Base oil viscosity (Pa·s)
η_i	Initial zero shear viscosity for fresh grease (Pa·s)
$\eta_{\dot{\gamma}_a}^l$	Grease viscosity at the aging shear rate $\dot{\gamma}_a$ (Pa·s)

τ	Shear stress within the aging gap (Pa)
τ_c	Crossover stress (Pa)
τ_{ps}	Shear stress during pre-shear (Pa)
τ_{y-HB}	Yield stress obtained from Herschel-Bulkley model (Pa)
τ_{y-osc}	Yield stress obtained from the oscillatory strain sweep test (Pa)
ϕ	Thickener volume fraction
ω	Rotational speed of the aging machine (rad/s)

Introduction

Grease is a widely applied lubricant, mostly used in rolling bearings. It is a multi-phase system consisting of three parts: thickener (3–30%), base oil (70–90%), and additives (Ref. 1). As a semi-solid material, grease has a high consistency that prevents leakage and creates a reservoir of lubricant inside the bearing. However, when subjected to the severe conditions within a rolling bearing, grease will undergo high shear, possibly causing deterioration. The degradation of this grease is usually reflected by the loss of its original consistency (softening), possibly yielding leakage from the bearing and, hence, starvation. It may also lead to continuous churning and high temperature. Both cases result in a reduced life of the bearing (Ref. 1). It is therefore valuable to investigate the mechanism of grease degradation and to develop predictive models for this.

Generally, the degradation of grease is classified as chemical or mechanical aging. This article focuses on the mechanical aging of lithium 12-hydroxystearate-thickened grease. This type of grease takes the major share of the worldwide industrial grease market and is widely applied in rolling bearings due to its wide temperature applicability, relatively good mechanical stability, water-resistant properties, and low cost (Ref. 1).

The most straightforward way to study grease aging is to obtain data from field tests directly, where the grease is worked in a real bearing (Ref. 2). Such field practice requires

Grease	NLGI	Thickener	Volume fraction of the thickener ϕ	Shape and average size of thickener	Base oil	Base oil viscosity at 25°C η_b
Li/M	3	Lithium 12-hydroxy stearate	14%	Twisted fiber $L \approx 2 \mu\text{m}$	Mineral oil	0.23 Pa·s
Li/SS	2	Lithium 12-hydroxy stearate	16%	Twisted fiber $L \approx 2 \mu\text{m}$	Semi-synthetic	0.07 Pa·s

a long timescale study. For example, in the work of Lundberg and Höglund (Ref. 3), aged samples were collected from the wheel bearings of railway wagons after years of service. Another drawback of this method is the fact that it is practically impossible to estimate the exact aging conditions—that is, the shear stress/rate, temperature, and time—to which the sample was subjected during operation.

Currently, there are two standards for measuring grease degradation. One is the mechanical stability test, where normal load and shear are applied; this is considered particularly meaningful in the situation where the bearing is subjected to vibrations and where the grease is continuously thrown back into the tracks. A typical mechanical stability test is the roll stability test (ASTM D 1831), where grease is sheared between a heavy roller (with a lead core) and a hollow rotating cylinder at an elevated temperature (generally 80°C). It was found that this test can be used to simulate the practical working conditions in automobile wheel bearings (Refs. 4–5) and in rolling bearings in railway wagons (Refs. 6–7). The other test is the shear stability test, where only shear is applied. This is considered important for bearings running under relatively stable working conditions. When subjected to continuous shear, it is observed that shear degradation of the grease results in the release of oil and thus provides lubricant replenishment (Refs. 8–9). In the “grease worker” (ASTM D 217), which consists of a closed cylinder and a piston plate with a number of holes, the grease is sheared through the holes during a well-defined number of strokes (usually 10,000 or 100,000 strokes).

The drawback of the two ASTM aging methods mentioned above is that the applied shear condition is not well defined, which makes it difficult to use these methods for the development of predictive aging models. To measure aging as a function of shear and time, a modified Couette rheometer was used in the shear measurements of grease (Ref. 10). Rezasoltani and Khonsari (Ref. 11) made use of a parallel-plate rheometer for the long-term shear tests of lithium-thickened grease. Aging in a rheometer provides a controlled aging process where the rheology can directly be measured as a function of time. However, the disadvantage of a parallel-plate configuration is that the shear field within the gap is not uniform, resulting in an inhomogeneous aging condition. In addition, in the current rheological study, leakage was observed in the parallel-plate geometry due to the centrifugal forces, and in the open Couette configuration due to the Weissenberg effect (Ref. 12). Hence, at some point during aging the measurement will become inaccurate. Therefore, more robust test rigs are required.

Rezasoltani and Khonsari (Ref. 11; p. 200) discovered a linear relationship between the energy input and the grease properties during grease aging tests using a parallel-plate rheometer. They mentioned that this “linear correlation remains

valid, regardless of the applied shear rate or the grease temperature.” This was verified using a journal bearing mounted between two rolling bearings to provide a uniform film along the circumference of the journal bearing (hence the journal bearing was not loaded) and a modified grease worker. The experimental data of the journal bearing test rig showed a slight deviation from the linear relation obtained from the rheological measurements at the end of their experiments, which was ascribed to grease separation from the journal and a slippage effect during the tests.

The aim of the current study is twofold: the first objective is to follow up on the work of (Ref. 11). The influence of grease mechanical degradation on its shear stability will be evaluated under similar aging conditions using lithium-thickened grease samples, but with an increased aging period, thus increasing the total amount of entropy generated. The second goal is to study the underlying mechanism responsible for the aging of lithium grease.

To achieve the first task, fresh greases will be sheared in an in-house-made Couette aging machine at specific shear rates for a set period of time. Then the grease is sampled and its rheological properties are measured. Though lubricating grease can be considered chemically stable at low temperatures (Ref. 13), Fourier transform infrared spectroscopy (FTIR) measurements will be performed for both the fresh and aged samples to confirm this. The physical processes occurring during mechanical degradation will be studied by measuring the change in the microstructure of the aged samples using atomic force microscopy (AFM).

Materials and Method

Two commercial lithium-thickened greases—Li/M and Li/SS—were used. Information on their composition is presented in Table 1 (Ref. 14).

Aging Tests

Test rig. In the current study, the grease has been aged by means of applying specific shear rates for a set period, similar to what is done in a grease worker. However, the shear rate is now well defined. Normal load (or hydrostatic pressure) will not be applied at first (so only the shear stability of the grease will be studied). The grease should be aged in a closed system, where leakage is avoided. Another requirement for the new test rig is that a sufficient amount of aged grease can be collected for subsequent rheological tests.

The new test rig (called a Couette aging test rig) is shown (Fig. 1). The basic concept is analogous to a cylindrical viscometer in that the grease is sheared between a stationary housing case and a rotating bob that is driven by a motor and a belt transmission. The shear rate exerted over the grease can thus be calculated based on the input rotational speed and the geometry of the aging head. The temperature dur-

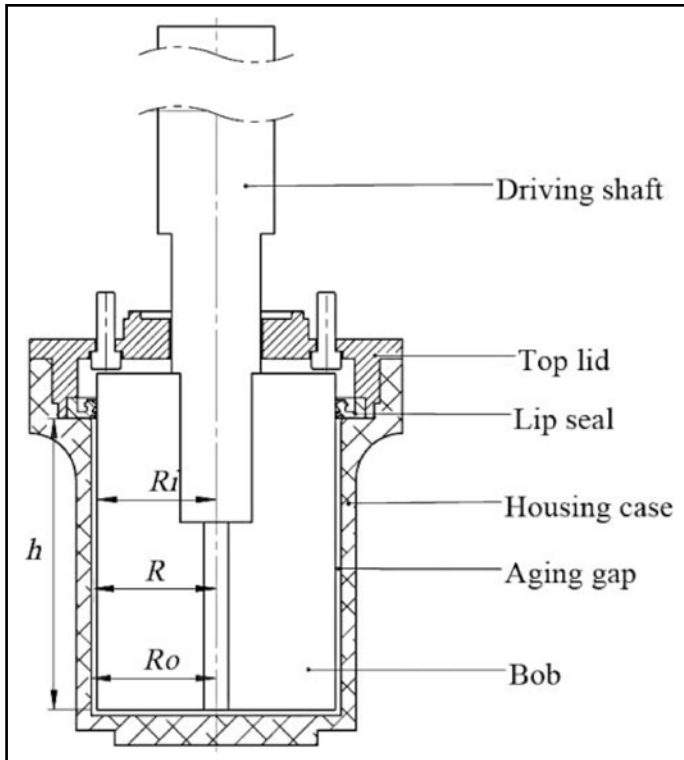

Figure 1 Couette aging test rig.

ing the aging procedure is captured by the thermocouple at the end of the aging head. To prevent grease leakage due to the Weissenberg effect, a lip seal is mounted on top of the aging gap. The rig was designed for a grease sample volume of $V_a = 5.1 \times 10^4 \text{ mm}^3$ for each aging test (where $R_i = 40 \text{ mm}$; $R_o = 42 \text{ mm}$; and $h = 100 \text{ mm}$; leaving a 2-mm gap between the rotating bob and the housing case).

Aging Condition

The aging rotational speeds are selected such that the imposed shear rates are similar to those applied on the aging tests performed by (Ref. 11). The input rotational speeds, corresponding shear rates, and aging periods are listed in Table 2.

Sampling. The lip seal (Fig. 1) generates a moderate amount of frictional heat, leading to a temperature gradient in the vertical direction. Together with possible thickener-oil separation due to shear, the thickener of the aged grease might no longer be evenly distributed inside the aging gap. The aged samples were therefore mixed for 500 strokes in an in-house-made grease worker before the rheological measurements were performed.

Rheological Measurements

Rheological measurements were performed for the fresh and aged grease samples using an MCR 501 Anton-Paar rheometer with parallel plate configuration. The viscosity was measured by steady-state flow curve measurements. In addition, oscillatory strain sweep measurements were performed to measure the grease's viscoelastic properties.

Preparation. There are three major concerns during rheological measurements: wall slip, loading history, and edge effects. To reduce the influence of wall slip, measuring plates with rough surfaces are recommended (Refs. 15–16). Therefore the plates were roughened by sand-blasting (top plate: $R_a = 1.5 \mu\text{m}$; bottom plate: $R_a = 2.3 \mu\text{m}$). Then, to minimize the initial deviation induced by the placing and loading procedure, the grease samples were first deposited on the bottom plate and the top plate, descended at a controlled speed until the measure position was reached, leaving a 1-mm measuring gap. Thereafter, pre-shear following a DIN standard (Ref. 17) was applied (pre-shear at $\dot{\gamma}_s = 100 \text{ s}^{-1}$ for 60 s at 25°C). Subsequently, the accumulated grease at the plate periphery was carefully removed with a spatula. See Figure 2 for the loading and pre-shear procedure.

As a thixotropic material, regeneration of the thickener microstructure occurs after shearing the grease (Refs. 16 and 18). Therefore, before data collection, sheared grease is left to rest for a sufficient relaxation time. This duration will depend on the grease microstructure, thickener concentration, pre-shear condition, etc., and can be determined by a time sweep measurement.

Here the time dependency of the shear modulus was recorded while imposing an oscillatory shear well within the linear viscoelastic regime (the applied shear is sufficiently small to not disrupt the grease properties). The detailed procedure is as follows: after pre-shear, a 2-h oscillatory test was applied at a constant shear stress of 10 Pa, oscillation frequency $f = 1 \text{ Hz}$, and temperature $25 \pm 1^\circ\text{C}$. Both Li/M and Li/SS show a similar trend: the highest recovery of G' takes place during the first hour of relaxation and the value levels out afterwards, which is in agreement with the literature (Ref. 18).

As a consequence, a relaxation time of 60 min was applied prior to the tests. The application of pre-shear and sufficient relaxation guarantees that the deviation in the following rheological results can be controlled within a 10% spread, which satisfies the requirements for grease rheological measurement specified in DIN 51810-2 (Ref. 17).

Flow curve and oscillatory strain sweep measurement. Once the sample was prepared following the procedure described above, rheological tests were conducted. The flow curve measurement was performed at $25 \pm 1^\circ\text{C}$ with the shear rate increasing from 10^{-8} s^{-1} up to 10^2 s^{-1} . The oscillatory strain

Rotational speed (rpm)	Shear rate $\dot{\gamma}_a$ (s^{-1})	Aging time (h)				
		5	25	50	100	200
83	174	5	25	50	100	200
125	261	5	25	50	100	200
166	348	5	25	50	100	200

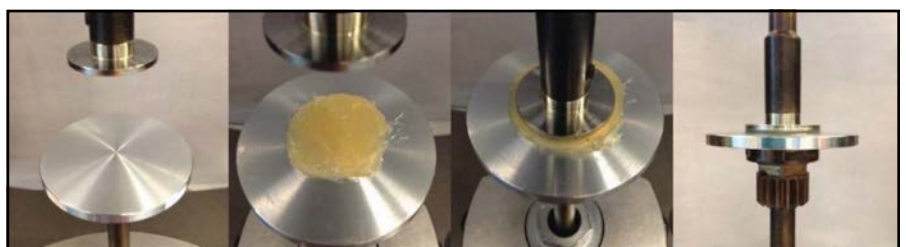

Figure 2 Loading and preshear procedure.

sweep measurement was performed at $25 \pm 1^\circ\text{C}$ at a frequency of 1Hz, with the shear strain sweeping from $10^{-3}\%$ to $10^3\%$. Each type of measurement was repeated at least twice. The repeatability of both flow curve and oscillatory strain sweep measurements was calculated based on the deviation from the average value of the duplicated test results (Table 3).

Deviation	Flow curve measurement	Oscillatory strain sweep
Li/M Li/SS	$\pm 7.1\%$ of the mean $\pm 4.6\%$ of the mean	$\pm 7.8\%$ of the mean $\pm 10\%$ of the mean

Data Process

Rheological output. Two representative results for both flow curve and oscillatory strain sweep measurements are presented in Figure 3. As shown in Figure 3a, the flow curve measurement shows shear thinning of grease under continuously increasing shear. A zero-shear viscosity $\eta_0 = 8.9 \times 10^5 \text{ Pa} \cdot \text{s}$ was obtained using the Cross model fit (Ref. 19). In Figure 3b the storage modulus G' , loss modulus G'' , and crossover stress τ_c are obtained from the plot directly; the yield stress τ_{-osc} was calculated using the method described by Cyriac et al. (Ref. 20).

Entropy generation calculation. The entropy generated per unit volume during aging (S_g) will be calculated based on the estimated frictional energy generated by the grease and recorded temperature during the aging process following the approach proposed by (Ref. 11).

If chemical reactions are neglected, the mechanical degradation of grease is such a slow process that “the major portions of the system are in homogeneous states that change slowly enough with time” (Ref. 21, p. 3). In this case, the entropy generated is equal to the accumulated energy divided by the aging temperature, which is produced through the absorption of heat (Ref. 22).

The recorded temperature showed that during aging, the variation in aging temperature was less than 2°C and the change in the system’s internal energy was negligible com-

pared to the energy accumulated during aging. Therefore, the accumulated energy is equal to the work exerted on the grease; that is, the integration of the grease frictional torque and the rotational speed over the aging time (Ref. 21). The entropy generated per unit volume S_g can thus be expressed as:

$$S_g = \frac{\text{work}/V_a}{\text{Temperature}} = \frac{\int \text{Torque} \cdot \omega dt}{\text{Temperature} \times V_a} \quad (1)$$

Here, ω is the input rotational speed, t is the aging time, and V_a is the grease volume inside the Couette aging rig. In the current rig, the torque generated by the grease cannot be recorded directly and is calculated using the shear stress acting over the area $2\pi Rh$ at a distance R from the central axis (Ref. 23):

$$\text{Torque} = 2\pi R h \tau \cdot R = 2\pi R^2 h \tau = 2\pi R^2 h \dot{\gamma} \eta | \dot{\gamma}_a \quad (2)$$

Here, $\dot{\gamma}_a$ is the applied shear rate presented in Table 2 and $\eta | \dot{\gamma}_a$ is the grease’s apparent viscosity at the aging shear rate. The geometrical notations (Eq. 2) are shown (Fig. 1). During the aging process the grease’s apparent viscosity is not constant. To obtain the viscosity at the aging shear rate ($\eta | \dot{\gamma}_a$), grease samples were collected after each aging period. Flow curve measurements were performed on these samples, from which the $\eta | \dot{\gamma}_a$ was estimated from a Cross model fit; an example of this $\eta | \dot{\gamma}_a$ is displayed as the aging point in Figure 3a.

In this way the torque during the aging process can be calculated periodically. Figure 4 shows an example of the torque distribution where Li/M was aged at 83 rpm for 200 h. The accumulated energy and the corresponding entropy generation density can be calculated by integrating the torque distribution over the aging period (Eq. 1).

The work and entropy induced by the 500-strokes mixture within the grease worker was calculated based on (Ref. 11); the entropy generated inside the grease worker is equal to the applied work W_{gw} divided by the ambient temperature T_{gw} ; where W_{gw} is the product of the average load and the piston distance for one stroke multiplied by the number of strokes

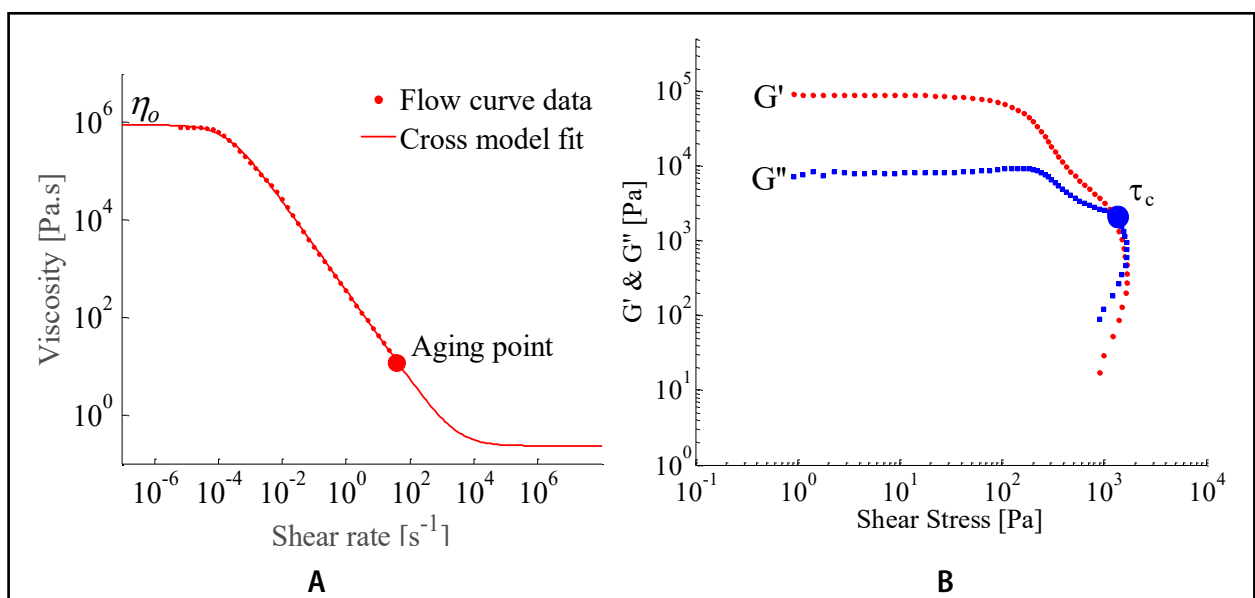

Figure 3 Typical rheological output obtained from an aged sample: (a) flow curve test and (b) oscillatory strain sweep test.

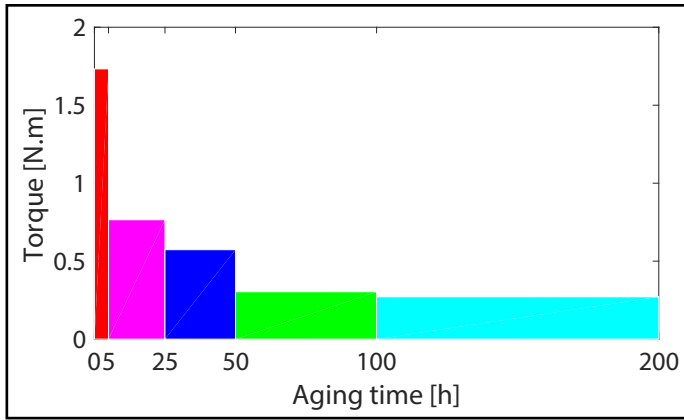

Figure 4 Calculated torque distribution for LiM aged at 83 rpm for 200 h.

(500).

The average load F for one stroke (both tension and compression) during the pre-shearing, recorded by a load cell mounted beneath the cylinder of the grease worker, was $F=8:75$ N for fresh Li/M and $F=6:20$ N for fresh Li/SS. The piston displacement for one full stroke was measured as $L_{piston}=5.68 \times 10^2$ m. The volume of the grease sheared inside the cylinder was $V_{gw}=1.23 \times 10^4$ mm³ and the ambient temperature $T_{gw}=25^\circ\text{C}=298$ K. The entropy generation per unit volume during the 500 strokes is thus calculated as:

$$S_{gw} = \frac{W_{gw}/V_{gw}}{T_{gw}} = \frac{500 \bar{F} \cdot L_{piston}}{V_{gw} \cdot T_{gw}} \quad (3)$$

For Li/M, $S_{gw}=6.8 \times 10^{-5}$ J/mm³K; and for Li/SS, $S_{gw}=4.8 \times 10^{-5}$ J/mm³K.

In addition, the pre-shear procedure before the rheological measurement creates entropy. As specified in the Preparation section, the grease sample will be pre-sheared at $\dot{\gamma}_{ps}=100$ s⁻¹ for 60 s at 25°C. Based on (Ref. 11), the entropy generation density during the pre-shear procedure S_{ps} within the rheometer can be expressed as:

$$S_{ps} = \dot{\gamma}_{ps} \cdot \frac{\int \tau_{ps} dt}{T_{ps}} \quad (4)$$

where

$\dot{\gamma}_{ps}$ is the shear rate applied during pre-shear ($\dot{\gamma}_{ps}=100$ s⁻¹), τ_{ps} is the shear stress recorded during pre-shear, t is time, and T_{ps} is the temperature during pre-shear (controlled at $T_{ps}=25^\circ\text{C}$).

For fresh Li/M, $S_{ps}=1.0 \times 10^{-5}$ J/mm³K and for fresh Li/SS, $S_{ps}=5.2 \times 10^{-5}$ J/mm³K.

The entropy generation density during the sample preparation, i.e. $-S_{gw}+S_{ps}$ is at least 100 times smaller than that generated during the aging test, and can therefore be neglected. For the following study, only the entropy density generated during the aging tests S_g will be taken into account.

Aging mechanism investigation. The microstructure of the grease thickener is studied using atomic force microscopy (AFM) in dynamic tapping mode, which

is widely applied on soft biological samples and greases (Refs. 24–26). The advantage of AFM over conventional scanning electron microscopy and transmission electron microscopy is that the soap structure can be observed without the need to remove the oil (Refs. 27–28). In addition, the sample preparation is limited to smearing a small volume of grease on a flat glass plate.

Results and Discussion

Verification of chemical reaction. The FTIR spectra (limited wave number range of 4,000–650 cm⁻¹) of fresh and aged Li/M are presented (Fig. 5). As an inhomogeneous material, grease thickener is not evenly distributed, resulting in the amplitude variation at zone 3,500–3,230 cm⁻¹ (- OH bond), 1,580 cm⁻¹ (COO⁻ asymmetric stretch), and 1,459 cm⁻¹ (- CH deformation), which indicates the difference in thickener concentration. However, no extra peaks are found between the fresh and aged samples' spectra; therefore, based on the detection accuracy of the current FTIR device, chemical reactions are not observed during the aging tests. A similar result was found for Li/SS. This was to be expected, because the maximum value of the recorded temperature during aging was low for the lithium-thickened greases (52°C for Li/M and 48°C for Li/SS). Thus the entropy calculation approach from (Ref. 11) can be applied (Ref. 21).

Thermodynamic characterization of grease mechanical degradation. In this section the results from aging grease in the Couette aging rig will be presented and compared to those found by (Ref. 11). As specified in the previous Methodology section, we used the same shear rates and the same definition of entropy as (Ref. 11). However, Rezasoltani and Khonsari (Ref. 11) used the net penetration value as a response parameter, a measure of the consistency of a grease sample. To compare the current rheological values to (Ref. 11) results, a relationship between the penetration value and the yield stress was applied (Ref. 29):

$$\tau_{y-HB} = 3 \times 10^{10} \cdot \Delta^{-3.17} \quad (5)$$

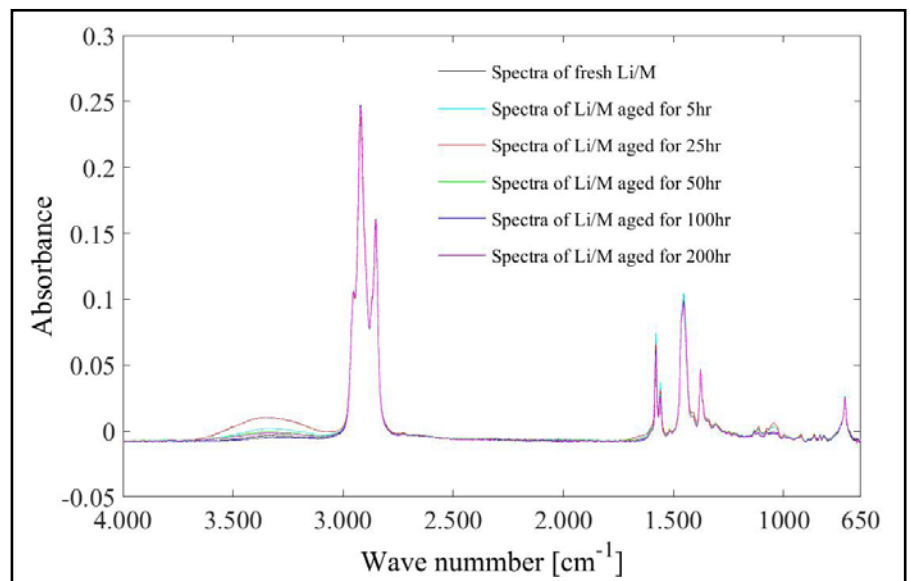

Figure 5 FTIR spectra of fresh and aged Li/M.

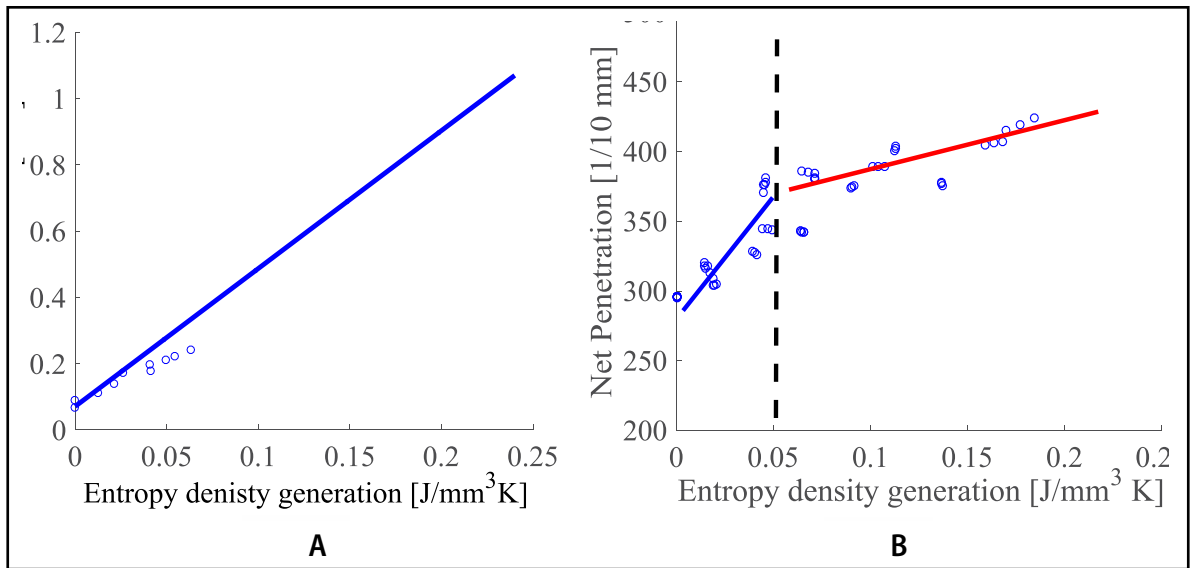

Figure 6 Comparison of penetration values against entropy generation density during the aging process: (a) reproduced from Rezasoltani and Khonsari (11) and (b) results from the current study (Li/M).

where

$\tau_{\gamma-HB}$ is the yield stress obtained from the flow curve data based on Herschel-Bulkley model (Ref. 29), and Δ is the cone penetration depth (10^{-1} mm).

Rezasoltani and Khonsari did not use the standard ASTM method to measure the penetration depth; however, it is assumed that they scale similarly. As listed in Table 2, 15 samples were prepared and examined for the effects of each type of grease on aging. The calculated penetration depth of Li/M against entropy generation density is presented in Figure 6b, together with the data rebuilt from the results of (Ref. 11) (Fig. 6a).

In the present case (Fig. 6b) a linear relationship can be observed in the early stage of the aging process; i.e. — $S_g < 0.05 \text{ J/mm}^3\text{K}$. At this point the degradation behavior changes. Again a linear behavior is observed — but with a different slope. The results from (Ref. 11) also show a deviation from the linear fit at higher values of entropy density; however, this was less pronounced. The aging behavior (Fig. 6b) can be translated into a fast deterioration phase at an early stage and a slower deterioration phase afterwards.

Figures 7 and 8 show the variation in the zero-shear viscosity with entropy generation per unit volume for Li/M and Li/SS, respectively, when subjected to three different shear rates. Again, two phases can be seen: a progressive degradation in the first stage followed by a rather slow deterioration afterwards. This agrees with the penetration depth variation against entropy generation per unit volume illustrated in Figure 6. Similar trends were also found from the literature survey (Refs. 30–32).

The viscosity versus entropy generation trend of lithium-thickened grease is similar to the viscosity versus shear rate (shear thinning) behavior of lubricating greases. At relatively low shear (or energy), the grease

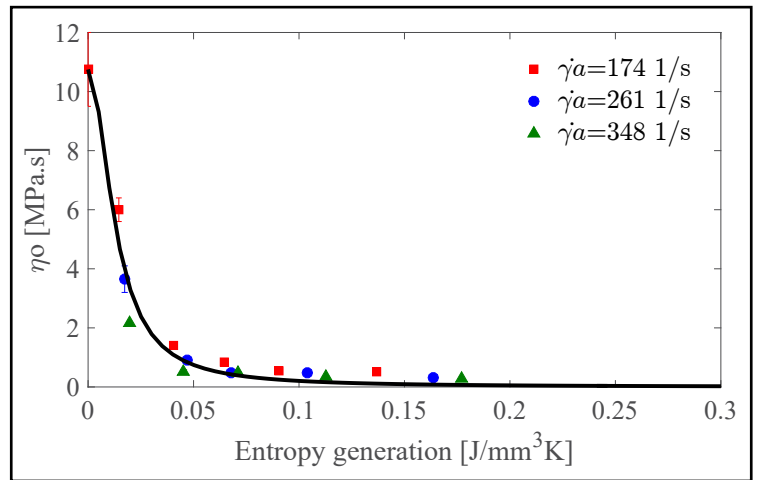

Figure 7 Zero-shear viscosity variation versus entropy generation density for Li/M.

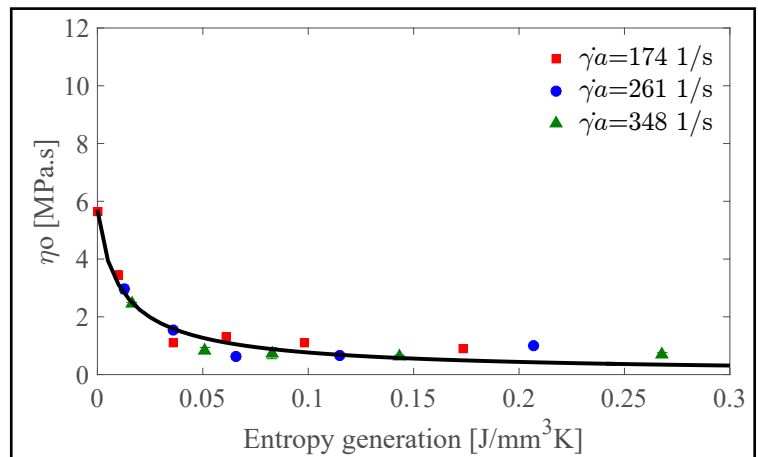

Figure 8 Zero-shear viscosity variation versus entropy generation density for Li/SS.

has an initial high viscosity (here indicated as η_i). However, when mechanical degradation starts, the sample begins to soften; after being subjected to a certain amount of entropy ($S_g=0.05 \text{ J/mm}^3\text{K}$), the viscosity levels out again with a weak degradation rate.

Therefore the formula of the Cross equation (Ref. 19), which is used to describe shear thinning behavior, was borrowed to describe the relationship between the variation in zero-shear viscosity and the entropy generation density during aging:

$$\eta_\infty = \frac{\eta_i - \eta_\infty}{1 + K \cdot S_g^m} + \eta_\infty, \tag{6}$$

where

η_i is the initial zero-shear viscosity for fresh samples; and η_∞ is the viscosity for infinitely long shearing, which is calculated using Batchelor's equation, $\eta_\infty = \eta_b (1 + 2.5 + 6.2^2)$ (Ref. 33); the base oil viscosity η_b and the phase volume are tabulated in Table 1; S_g is the generated entropy-per-unit volume during aging; K is the coefficient of degradation; and m is the exponent of degradation.

Equation 6 fits the data obtained from all three shear rates very well ($R^2=0.99$) (Figs. 7-8). This model has also been applied to the other three selected rheological properties: storage modulus G' , crossover stress τ_c , and yield stress τ_{y-osc} from the oscillatory test in the form of Equation 7 — called here the “grease aging equation”:

$$Y = \frac{Y_i - Y_\infty}{1 + K \cdot S_g^m} + Y_\infty, \tag{7}$$

where

Y represents the rheological properties, Y_i represents the initial rheological value for fresh grease, Y_∞ represents the second-stage value for the longtime-aged sample, and K and m are the coefficient of degradation and the exponent of degradation, respectively.

Each grease will have its own aging master curve, or grease aging equation, with its specific parameters (Table 4).

		Y_i	Y_∞	K	m	R^2
η_0 (Pa·s)	Li/M	1.1×10^7	0.34	4.5×10^3	1.9	0.99
	Li/SS	5.7×10^6	0.11	5.0×10^3	0.89	0.99
G' (Pa)	Li/M	9.0×10^4	2.2×10^3	5.9×10^3	2.2	0.99
	Li/SS	8.0×10^4	9.3×10^3	1.0×10^3	1.6	0.98
τ_c (Pa)	Li/M	1.2×10^3	1.0×10^2	4.0×10^3	2.2	0.99
	Li/SS	7.2×10^2	2.7×10^1	4.0×10^2	1.2	0.99
τ_{y-osc} (Pa)	Li/M	70	3	1.8×10^1	1.1	0.91
	Li/SS	50	6	6.6×10^2	1.9	0.95

Grease aging mechanism. The generation of entropy demonstrates a dissipative process, which brings disorder to the system and, in this case, probably the collapse of the grease's microstructure. According to the literature, the consistency and rheological properties of fibrous structured greases are closely related to the geometry and distribution of the network structure formed by the fibers (Refs. 4-5; 25 and 34).

As shown in Figure 6b, there are two aging phases with different degradation rates. According to (Ref.35), the entropy generation rate is closely related to the system degradation rate. Here the system degradation rate is measured by the changes in rheological properties per unit of time (macro-

scopically) and the change in the thickener network (microscopically). The entropy generation rate per unit of volume can be expressed as:

$$\dot{S}_g = \frac{\text{Torque} \times \omega / V_a}{\text{Temperature}}. \tag{8}$$

The entropy generation rate per unit volume and the degradation rate of the zero-shear viscosity η_0 for Li/M during the aging tests are plotted against aging time in Figure 9. AFM measurements of the grease were taken at different points in time and are also shown (Fig. 9). The drawings are interpretations of the AFM pictures that will help in the explanation of the results.

Figure 9 shows the entropy generation rate, rheology, and microstructure of Li/M during aging. Although only the degradation rate for zero-shear viscosity is shown, the plots for crossover stress, storage modulus, and yield stress are very similar. The thickener microstructure for fresh Li/M is visualized as a twisted fibrous network where the fibers are typically 0.1–0.2 μm wide and up to 3 μm long. Initially, the sample shows high consistency. When the mechanical degradation is initiated, energy is dissipated into the system (high S_g), disrupting the network crosslinks and aligning the fibers (as presented in the first two drawings and AFM results). This results in a fast degradation in grease properties. This stage can be characterized by the coefficient of degradation K (values of K are listed in Table 4) and it ends when the fibrous network becomes fragmented (until 50 h) (Fig. 9).

After this fast degradation stage the aged sample becomes a mixture of particle-like microfragments of thickener (with an average length of 0.1 μm) dispersed in the oil, and the deterioration process slows down (the degradation rate is approaching zero after 100 h of aging (Fig. 9). Such behavior suggests that once the fibrous structure is completely destroyed, the grease rheology will become stable. With the deceleration of the aging process, the entropy generation rate becomes smaller and remains constant.

However, the existence of microfragments or nanosized thickener fibers (Ref. 34) still gives the aged grease a higher consistency compared to that of the bled oil (see the second-stage values Y_∞ for the aged samples presented in Table 4). According to the R2F bearing tests performed (Ref. 9), small volumes of viscous liquid were found in the cage pockets — which was assumed to lubricate the rolling track. Infrared spectroscopy showed that this lubricant was a mixture of oil and thickener, and more viscous liquid was found along with the running. Such viscous liquid can be considered as the aged grease at the second stage, where it has both better flowability — compared to the fresh grease (for lubricant replenishment) — and higher viscosity compared to the base oil (for film construction).

Spiegel, et al. (Ref. 31) described the fragmented thickener as spherical particles and modeled the second-stage mechanical aging using a Wöhler curve. Their theory suggests that when subjected to continuous shear, these spherical particles start rolling and the governing aging mechanism is fatigue. Considering the results (Fig. 9), in the second stage, the thickener structure has become fragmented during the

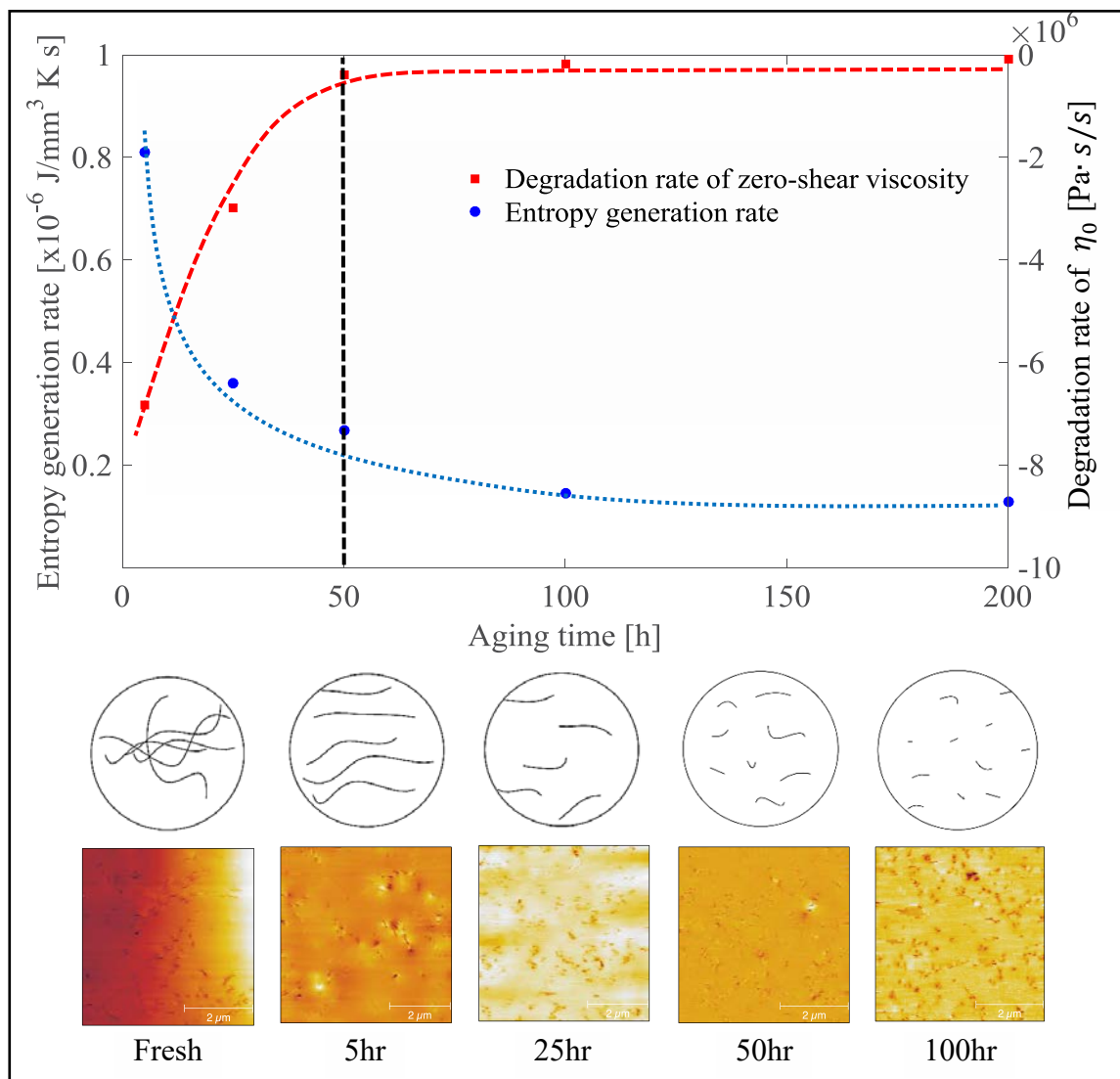

Figure 9 Aging of Li/M; cartoon and AFM results for different aging stages.

second phase and the grease ages at a slower rate, compared to the first aging phase. Currently the grease rheology during aging is assumed to end up at an infinite value Y_{∞} (Table 4; Figs. 7–8). A similar aging mechanism is also observed for Li/SS. To confirm Spiegel's (Ref. 31) theory, prolonged aging tests will be needed.

Conclusion

In this study the mechanical shear degradation of lithium-thickened grease was evaluated using an in-house-developed aging rig and a commercial rheometer. It was found that this grease loses its original consistency during aging and shows a two-phase aging behavior. In the first phase, primarily reorientation and breakage of the thickener network take place, resulting in a progressive drop in the grease's rheological properties. After this, the aging is dominated by the breakage of smaller fiber fragments and the grease degrades at a much slower rate (but currently considered stable). A grease shear aging equation (Eq. 7) was introduced to describe such two-phase behavior. By making use of the entropy concept, this equation is capable of covering the change in grease's rheo-

logical properties when aged at different shear rates. This aging behavior is closely related to the entropy generation rate and the change in the thickener network during the aging process: due to breakage of the thickener structure, grease degrades and the aging rate is positively correlated to the entropy generation rate. According to (Ref. 11) the shear aging at various shear rates and temperatures can be described by a single (master) curve using the entropy concept. In the current study the entropy concept was confirmed using aging at different shear rates; the current test rig does not allow for variance of the aging temperature. It is therefore recommended to further study the impact of temperature on the shear aging behavior of grease.

Funding. The authors thank SKF Engineering and Research Centre for the financial support of this work. **PTE**

References

1. Lugt, P. M. *Grease Lubrication in Rolling Bearings*, 2013, New York, NY, Wiley & Sons.
2. Salomonsson, L., G. Stang and B. Zhmud. "Oil/Thickener Interactions and Rheology of Lubricating Greases," *Tribology Transactions*, 50(3), 2007, pp 302–309.

3. Lundberg, J. and E. Högglund. "A New Method for Determining the Mechanical Stability of Lubricating Greases," *Tribology International*, 2000, 33(3), pp 217-223.
4. Bondi, A., A.M. Cravath, R.J. Moore and W.H. Peterson. "Basic Factors Determining the Structure and Rheology of Lubricating Grease," *The Institute Spokesman*, 1950, 13(12), pp 12-18.
5. Moore, R. J. and A.M. Cravath. "Mechanical Breakdown of Soap-Based Greases," *Industrial & Engineering Chemistry*, 1951, 43(12), pp 2892-2897.
6. Lundberg, J. "Grease Lubrication of Roller Bearings in Railway Wagons. Part 1: Field Tests and Systematic Evaluation to Determine the Optimal Greases," *Industrial Lubrication & Tribology*, 2000, 52 (1), pp 36-43.
7. Lundberg, J. and S. Berg. "Grease Lubrication of Roller Bearings in Railway Wagons. Part 2: Laboratory Tests and Selection of Proper Test Methods," *Industrial Lubrication & Tribology*, 2000, 52(2), pp 76-85.
8. M'erieux, J., S. Hurley, A.A. Lubrecht and P.M. Cann. "Shear Degradation of Grease and Base Oil Availability in Starved EHL Lubrication," *Tribology Series*, 2000, 38, pp 581-588.
9. Cann, P. M., J.P. Doner, M.N. Webster and V. Wikstrom. "Grease Degradation in Rolling Element Bearings," *Tribology Transactions*, 2001, 44(3), pp 399-404.
10. Paszkowski, M. "Identification of the Thixotropy of Lithium Greases," *16th International Colloquium Tribology*, 2008, Esslingen, Germany.
11. Rezasoltani, A. and M.M. Khonsari. "On the Correlation between Mechanical Degradation of Lubricating Grease and Entropy," *Tribology Letters*, 2014, 56(2), pp 197-204.
12. Schramm, G. "A Practical Approach to Rheology and Rheometry," 1994, Haake: Karlsruhe, Germany.
13. Ito, H., M. Tomaru and T. Suzuki. "Physical and Chemical Aspects of Grease Deterioration in Sealed Ball Bearings," *Lubrication Engineering*, 1988, 44(10), pp 872-879.
14. Cyriac, F., P. Lugt, R. Bosman, C. Padberg and C. Venner. "Effect of Thickener Particle Geometry and Concentration on the Grease EHL Film Thickness at Medium Speeds," *Tribology Letters*, 2016, 61(2), pp 1-13.
15. Czarny, R. "The Influence of Surface Material and Topography on the Wall Effect of Grease," *Lubrication Science*, 2002, 14(2), pp 255-274.
16. Paszkowski, M. "Assessment of the Effect of Temperature, Shear Rate and Thickener Content on the Thixotropy of Lithium Lubricating Greases," *Proceedings of the Institution of Mechanical Engineers - Part J: Journal of Engineering Tribology*, 2013, 227(3), pp 209-219.
17. Deutsches Institut für Normung. "Testing of Lubricants — Determination of Shear Viscosity of Lubricating Greases by Rotational Viscosimeter — Part 1: System of Cone/Plate," 2007.
18. Paszkowski, M., S. Olsztyń'ska-Janus and I. Wilk. "Studies of the Kinetics of Lithium Grease Microstructure Regeneration by Means of Dynamic Oscillatory Rheological Tests and FTIR-ATR Spectroscopy," *Tribology Letters*, 2014, 56(1), pp 107-117.
19. Cross, M. M. "Rheology of Non-Newtonian Fluids: A New Flow Equation for Pseudo-Plastic Systems," *Journal of Colloid Science*, 1965, 20(5), pp 417-437.
20. Cyriac, F., P.M. Lugt and R. Bosman. "On a New Method to Determine the Yield Stress in Lubricating Grease," *Tribology Transactions*, 2015, 58(6), pp 1021-1030.
21. Rezasoltani, A. and M. Khonsari. "Reply to Comment by Chung on 'On the Correlation between Mechanical Degradation of Lubricating Grease and Entropy,'" *Tribology Letters*, 2015, 60(1), pp 1-4.
22. Tolman, R. and C. P.C. Fine. "On the Irreversible Production of Entropy," *Reviews of Modern Physics*, 1948, 20(1), pp 51-77.
23. Godec, D., A.Y. Malkin and A.I. Isayev. "Rheology — Concepts, Methods & Applications," *Polimeri*, 2006, 27(1), pp 282-283.
24. Hoefnagels, J. P. M. "Overview of Microscopic Characterization Techniques," Eindhoven, The Netherlands, Eindhoven University of Technology.
25. Sanchez, M. C., J. Franco, C. Valencia, C. Gallegos, F. Urquiola and R. Urchegui. "Atomic Force Microscopy and Thermo-Rheological Characterization of Lubricating Greases," *Tribology Letters*, 2011, 41(2), pp 463-470.
26. Paszkowski, M. and S. Olsztyń'ska-Janus. "Grease Thixotropy: Evaluation of Grease Microstructure Change Due to Shear and Relaxation," *Industrial Lubrication & Tribology*, 2014, 66(2), pp 223-237.
27. Hurley, S. and P.M. Cann. "Examination of Grease Structure by SEM and AFM Techniques," *NLGI Spokesman*, 2001, 65(5), pp 17-26.
28. Delgado, M. A., J.M. Franco, C. Valencia, E. Kuhn and C. Gallegos. "Transient Shear Flow of Model Lithium Lubricating Greases," *Mechanics of Time-Dependent Materials*, 13(1), pp 63-80.
29. Spiegel, K., J. Fricke and K. Meis. "Coherence between Penetration and Flow Limit of Greases," *Tribologie und Schmierungstechnik*, 1991, 38(6), pp 326-331.
30. Plint, M. and A. Alliston-Greiner. "A New Grease Viscometer: A Study of the Influence of Shear on the Properties of Greases," *NLGI Spokesman*, 1992, 56(2), pp 7-15.
31. Spiegel, K., J. Fricke and K. Meis. "Die Fließeigenschaften von Schmierfetten in Abhängigkeit von Beanspruchung, Beanspruchungsdauer und Temperatur," 2000, *International Colloquium Tribology*: Esslingen, Germany.
32. Kuhn, E. "Experimental Grease Investigations from an Energy Point of View," *Industrial Lubrication & Tribology*, 1999, 51(5), pp 246-251.
33. Barnes, H. A., J.F. Hutton and K. Walters. *An Introduction to Rheology*, Amsterdam, 1989, The Netherlands, Elsevier.
34. Yoshiyuki, S., N. Yusuke, I. Yusuke, S. Hiroki and F. Yukitoshi. "Characterization of Nano Size Thickener Fiber in Grease by SAXS," *World Tribology Congress*, 18-13 September, Torino, Italy.
35. Bryant, M. D., M.M. Khonsari and F.F. Ling. "On the Thermodynamics of Degradation," *Proceedings of the Royal Society of London A: Mathematical, Physical and Engineering Sciences*, 2008, 464 (2096).

Yuxin Zhou is a Ph.D. candidate working since 2014 in the Surface Technology and Tribology group at the University of Twente (Netherlands), focusing on the aging mechanism of lubricating grease. He received his BSc degree in marine engineering at Dalian Maritime University (China), studying bearing film thickness measurement, and was awarded an MSc degree in advanced mechanical engineering at Imperial College London (UK), projecting the bearing surface optimization.



Rob Bosman studied mechanical engineering and tribology at the University of Twente in The Netherlands (MSc. 2007, Ph.D. 2011). He then worked at Pentair FairBanks-Nijhuis for 2 years as an R&D and reliability engineer, after which he returned to the university as an assistant professor and is currently an associate professor. Along with his professorship Bosman since 2014 has worked part-time at Shell Rijswijk R&D as a research coordinator.



Piet M. Lugt studied mechanical engineering and tribology at the University of Twente in The Netherlands (MSc. 1988, Ph.D. 1992). He then worked at the Technical University of Delft in chemistry and vehicle dynamics until 1995 when he joined SKF Research, where he has fulfilled several positions in tribology and lubrication — presently as a senior scientist. He has also been a part-time professor at Luleå Technical University, Sweden (2005-2008) and since 2011 at the University of Twente. Lugt is the author of *Grease Lubrication in Rolling Bearings* — a book regarded as a major contribution to the industry.



For Related Articles Search

at www.powertransmission.com

GREAT SCOTT!

It's the future!

OK, you blinked and missed last month's issue of *Power Transmission Engineering*. Fortunately, you don't need a DeLorean to travel back in time — just a computer and working fingers.

Hop online and visit www.powertransmission.com to view the entire magazine.

At the PTE Library, every issue is free for download.
All you have to do is go and get it

www.powertransmission.com

Baldor Motor Basics: Premium Efficiency Motors

Edward Cowern, P.E.

Former Baldor motors expert Edward Cowern PE, is a name known and respected by many in the electric motor industry. During his tenure at Baldor, Cowern — now enjoying his retirement — was tasked with producing a number of motor- and basics-related tutorials. The tutorials were primarily in response to a steady flow of customer questions regarding motors and applications. Today's customers continue asking questions and seeking answers to address their various motor-related concerns. We hope you find these articles useful and would appreciate any comments or thoughts you might have for future improvements, corrections or topics.

(Following is Part 8 of Baldor Motor Basics — a continuing series of articles — courtesy of the Baldor Electric Co. — dedicated primarily to motor basics; e.g. — how to specify them; how to operate them; how — and when — to repair or replace them, and considerably more.)

Please note that while current regulations for the U.S. only allow production of premium efficient three-phase motors in the 1-500 hp range, the information in this article is still relevant when comparing to older motors which may be installed in plant equipment — E. Cowern

Introduction

Conservation through lighting alterations using different bulbs, ballasts and light sources is well understood and easy to achieve. The use of improved efficiency three phase induction motors has not been as accepted. There are a number of reasons why conservation efforts with motors have not been as popular.

Light bulbs are sold by input ratings or watts. With the input rating being so prominent, it's easy to understand that if a 40-watt bulb is replaced by a 34 watt bulb, there will be savings. But, unlike light bulbs, electric motors are sold by output rating (horsepower) rather than input wattage. As a result, the measure used to evaluate differences in motors is the efficiency rating and efficiency shows up in the fine print and is not as easily understood as the wattage of bulbs.

The second reason lighting is different from motors is that lights are usually on or off — not in between. But motors can be running at full load, half load, quarter load, or no load. Frequently when motors are coupled through clutches to an intermittent motion system the motor may spend a lot of the time operating with no load. Similarly, air compressors may run unloaded much of the time. As a result of varying load levels and intermittent loading, projected savings based on full load efficiencies may not materialize.

That's the bad news.

The good news is that premium efficiency motors, with their enhanced designs, result in lower operating costs at any level of loading including no load. For example, the no load losses of a five horsepower premium efficiency motor might be 215 watts. The no load losses of a standard motor of the same type might be 330 watts. Figure 1 shows a plot of watts loss for vari-

ous load levels on a conventional motor versus the premium efficiency motor of the same type. Curves of this type change dramatically with motor size, but trends are the same.

The Basics

The process of converting electrical energy to mechanical

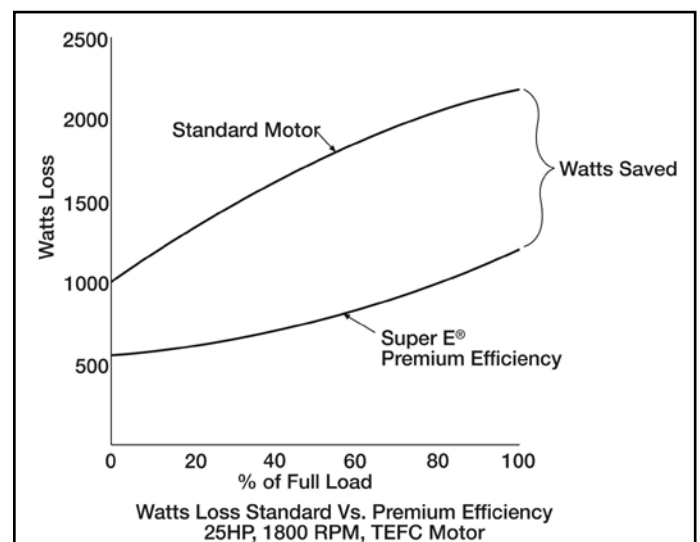

Figure 1 Plot of watts loss for various load levels on conventional motor versus premium efficiency motor of same type.

energy is never perfect. As much as we would like to have a 100% efficient motor, it is impossible to build a machine that will take 746 watts of electricity (the equivalent of 1 hp) and convert it to 1 hp of mechanical output. It always takes somewhat more than 746 watts to yield 1 hp's worth of output. It does become easier to approach 100% perfection with large motors than with small. For example, if the conversion process were only 50% efficient, then it would take 1,492 watts of electricity to get 1 hp's worth of output. Luckily, in industrial motors the conversion process is usually more efficient than this. The efficiency of standard industrial three phase motors usually runs from a level of approximately 75% at 1 hp up to 94% at 200 hp. The curve shown in Figure 2 illustrates the general trend of motor efficiency versus motor size for standard and premium efficiency motors.

A reasonable question might be, "Where does the extra

energy go?” In all cases, energy not delivered to the shaft becomes heat that must be carried away from the outside surface and internal parts of the motor.

As an additional complication, the efficiency of electric motors varies depending on the amount of load on the motor. Figure 3 shows the general trend of motor efficiency based on motor loading. For example, when a motor is running idle (no load on the output shaft), energy is being used by the motor to excite the magnetic field and overcome the friction of the bearings and the so-called windage of the rotating portion of the motor. Thus the efficiency at no load is 0%. The efficiency climbs as torque is applied to the motor shaft up to the point where the efficiency levels out and ultimately drops from its highest level. In most motors the peak efficiency will occur somewhere between 50 and 100% of rated load. The point at which it peaks is determined by the specific motor design.

To show where the losses occur in a fully loaded motor, Figure 4 gives a general outline of the flow of power through the motor. The flow is shown as 100% electrical power going to the motor on the left side and the various losses involved in converting the power until it ends up as mechanical power at the output shaft. In this case, the major losses are stator resistance loss (so-called Stator I²R). This is the largest single loss in the motor. It is followed by rotor resistance loss (Rotor I²R). Next come losses that are described as the core losses. These are losses resulting from the cycling magnetic forces within the motor. The more specific terms used for these losses are hysteresis and eddy current losses. Hysteresis loss is a result of the constant re-orientation of the magnetic field within the motor’s steel laminations. Eddy current losses occur because the re-orientation of magnetic forces within the steel produces small electrical currents in the steel. These electric currents circulate on themselves and produce heat without contributing to the output of the motor. Hysteresis and eddy current losses occur in both the stationary and the rotating portion of the motor, but the largest share occur in the stationary portion.

15 Hp, 4-Pole, 3-Phase Phase Motor Typical Energy Flow

Next come the so called friction and windage losses. In this case the friction is the friction of the bearings. Ball bearings are extremely efficient, but still there are some losses generated as a result of the rolling of the ball bearings. Windage loss is a combination of things. First, the rotor spinning in the air creates some drag. The faster it spins, the more drag it creates with the surrounding air. In addition, there has to be air flow through or over the motor to carry away heat being generated by the losses. In most cases a fan is either incorporated on the shaft of the motor or designed in to the ends of the motor’s rotor to provide air flow for cooling. This requires energy and uses input without developing output.

Finally, there is a category called stray load losses. These are losses that cannot be accounted for in the previous four categories. Generally, stray load losses are dependent on motor loading and increase as load is applied.

The accepted domestic test for electric motor efficiency is the one defined by IEEE Standard 112 Method B. This test method

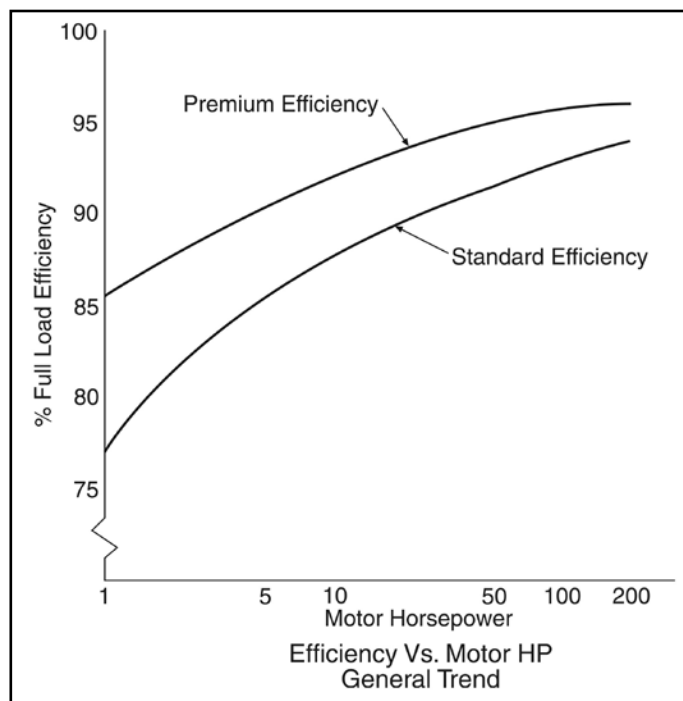

Figure 2 Curve shown illustrates general trend of motor efficiency versus motor size for standard and premium efficiency motors.

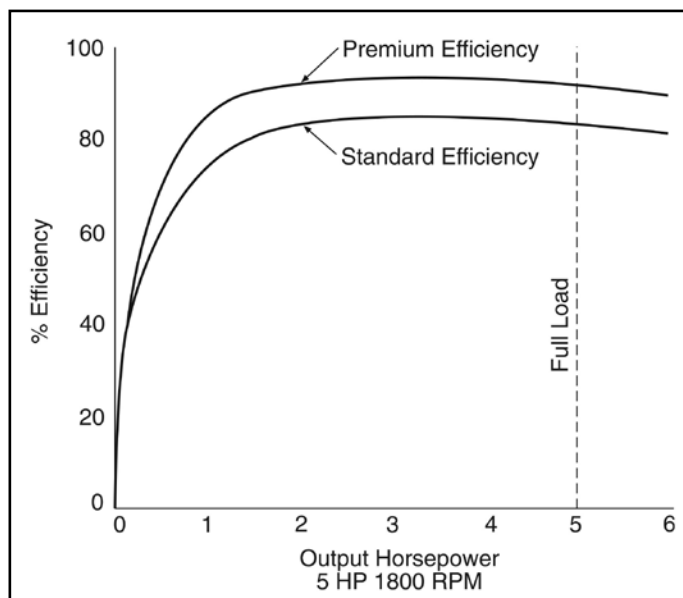

Figure 3 General trend of motor efficiency based on motor loading.

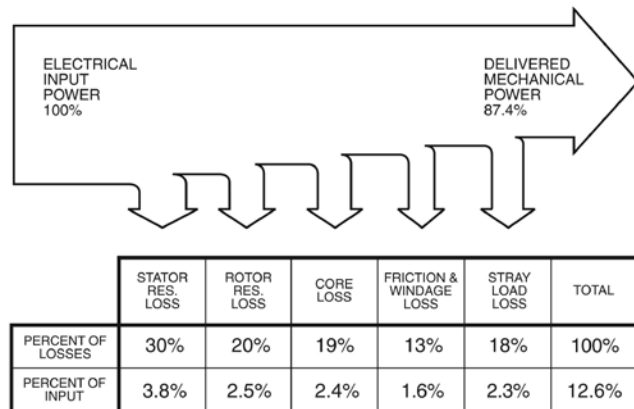

Figure 4 General outline of flow of power through motor shows where losses occur in fully loaded motor.

accounts for all of these losses when the motor's performance is measured on a dynamometer. More about this later.

The energy flow diagram shown in Figure 4 would be typical for a standard motor of 15 hp. The mix of losses will vary somewhat based on motor size, but the diagram shows the overall trend of where the energy goes. It is important to note that many of the core losses and friction and windage losses are independent of the amount of load on the motor, whereas stator resistance loss, rotor resistance loss and stray load losses get larger as torque is applied to the motor shaft. It is the combination of these losses that produces the result of efficiency versus load shown in Figure 5.

Efficiency Improvement

To improve efficiency of a motor the five categories of losses mentioned previously are worked on one at a time. Reducing the stator resistance loss involves both magnetic and electric modifications that allow for more copper wire to be inserted in the slots of the stator of the motor. In general, the stator lamination design has to have slots large enough

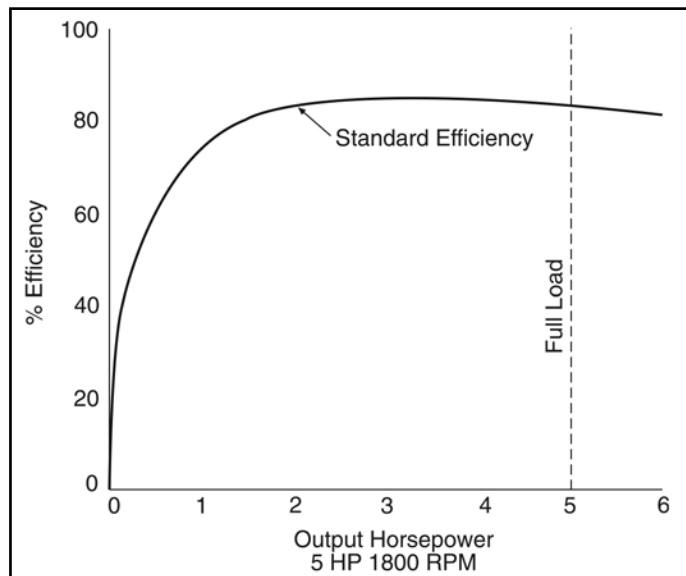

Figure 5 While many core, friction and windage losses are independent of motor load, stator resistance, rotor resistance, and stray load losses grow as torque is applied to motor shaft.

to accept more copper wire. For example, in household wiring #12 gauge wire has higher ampacity than #14 gauge wire. The same is the case in motors. But increasing the wire's size without increasing the amperage load results in less loss. In addition, the best reasonably priced conductor material must be used. In the case of electric motors, the best reasonably priced conductor material is copper.

The second largest loss, rotor resistance, is reduced by using special rotor designs with larger areas of aluminum conductor. Using larger "rotor bars" results in lower rotor resistance and less rotor energy loss.

Hysteresis and eddy currents are reduced in many different ways. Hysteresis loss can be reduced by using improved steels and by reducing the intensity of the magnetic field. Eddy current losses are lowered by making the individual laminations that comprise the stator (and rotor) thinner and insulating

them more effectively from each other.

In the case of friction and windage — there is little that can be done to improve the efficiency of bearings, but if the previously outlined steps have been effective in reducing total losses, the size of the cooling fan can be reduced — which helps increase motor efficiency.

The last component of losses is stray load loss. In this case, various manufacturing techniques are used to reduce stray load losses. With each of the five elements being worked individually and collectively, substantial improvements in motor efficiencies can be achieved.

Basis of Comparison

There are many different terms used to compare efficiencies of one motor to another. The two most often heard are nominal efficiency and guaranteed minimum efficiency. It is easy to get confused as to what basis should be used for determining potential savings from efficiency upgrades. The basis for nominal efficiency ratings can be explained in the following manner. If a large batch of identical motors were to be made and tested, the nominal efficiency would be the average efficiency of the batch. Due to manufacturing tolerances, some units might be less efficient and others more efficient. However, the nominal is the predictable average of the lot.

The second term used is guaranteed minimum efficiency. The guaranteed minimum recognizes the variations from one motor to the next and sets an arbitrary low limit. It says in essence, none of the motors in the batch will be less efficient than this.

With these two choices, what should be the basis of comparison?

If you had to stake your life on the result and it involved a single motor, then guaranteed minimum efficiency would be the one to use. However, if you're considering a number of motors in a range of sizes, and you're not held precisely to what the final minimum result would be, then nominal efficiency is the proper basis of comparison. Nominal efficiency also makes it easier because nominal efficiency is stamped on the nameplate of the motor. In addition, nominal and minimum guaranteed are related to each other by a formula established by the National Electrical Manufacturers Association (NEMA). So comparing different motors on the basis of "nominal" is really equivalent to comparing on the basis of minimum guaranteed.

Of more importance is the standard by which the efficiency is going to be determined. The standard should *always* be IEEE 112, Method B; of all standards developed for determining efficiency of motors, this is one of the most rigorous.

Other standards that are used, particularly some international standards, do not demand such rigorous testing. In some cases efficiency is merely calculated, rather than measured. In virtually all cases the "other" standards will give efficiencies higher than the tougher IEEE 112 standard. The correct basis of comparison should be that all motors be compared on the same standard. The IEEE method also measures the efficiency in the hot running condition. This makes it more accurate because the efficiency of the motor will fall slightly as operating temperature rises.

A Few Precautions

The result of using premium efficiency motors is not necessarily without some pitfalls. For example, premium efficiency motors run somewhat faster (have less slip) than their less-efficient counterparts. A premium efficiency motor might run at a full load speed of 1,760 rpm. The motor it replaces might be running at 1,740 rpm. This can help or hurt conservation efforts, depending on the type of load the motor is driving. For example, if it is driving a conveyor handling bulk materials, the higher speed will result in getting the job done faster. Also, if the conveyor has periods of light load, the reduced losses of the motor will save energy during that period of time.

The same situation exists on many pumping applications, where a specific amount of fluid is going to be used to fill a tank. If the motor runs faster, the work is completed sooner and the motor is shut down earlier. In these cases the consequence of the increased speed does not result in increased energy use. But there are applications such as chilled water circulating pumps where the extra speed can reduce expected savings.

The reason this can happen is that centrifugal pumps, along with other types of variable torque loads such as blowers and fans, require horsepower proportional to speed cubed. As a result a slight increase in speed can result in a sharper increase in horsepower and energy used. A typical example might be where the original motor is directly connected to a centrifugal pump. The original motor's full load speed is 1,740 rpm. The replacement premium efficiency motor, driving the same pump, has a higher speed of 1,757 rpm. The resulting difference of 1% will increase the horsepower required by the pump by $1.01 \times 1.01 \times 1.01 = 1.03$. Thus the horsepower required by the load is increased by 3% above what it would be if the pump speed had remained the same. Even with increased speed there remains, in most cases, some improvement in efficiency and reduction in energy usage, although it may not be what you hoped to achieve.

For fans and blowers the same thing would hold true if no changes take place to bring the equipment speed back to the original value. For example, if a motor drives a fan with a belt drive and the fan speed is 650 rpm, hanging the motor and using the same exact pulley and belt would increase the fan's speed and the horsepower required. This could reflect back as extra energy drawn from the power system. However, if an adjustment is made in the ratio between the pulleys to restore the fan speed to the original value, then the anticipated savings will materialize. These types of challenges make it desirable to look at efficiency upgrading as a "system" rather than strictly a motor consideration.

Driven Equipment Efficiency

As consumers, we are faced with energy efficient ratings on new refrigerators, air conditioners, hot water heaters, etc. The same type of data is usually not nearly as available on machinery purchased for industrial and commercial installations. For example, not all pumps with the same performance specifications have the same efficiency. Similarly not all air compressors have the same efficiencies. Some air compres-

sors have dramatically better efficiencies than others — especially when operated at less than full load. At first glance it looks like a problem of evaluating one versus the other could be insurmountable. However, a good vendor should be willing to share certified performance information.

Proper Sizing

In addition to the challenge of different efficiencies from different equipment manufacturers there is also the matter of selecting properly sized equipment. For example, a pump oversized for the job may be much less efficient than a pump properly sized. Similarly, an air compressor oversized for the job may be much less efficient than one selected to more closely match actual requirements.

Evaluation

There are a great many ways to approach capital investment and determine rates of return, payback periods, present worth, etc. Most of these are good for large capital investments where there may be risk involved if the project doesn't work out or if the product changes or is affected by market dynamics. Electric motors and other conservation measures tend to be a simpler problem and usually do not need the rigorous mathematical treatment found in these more complicated analysis approaches. **Formulas to determine savings are found in the appendix of this paper.**

Ideal Motor Loading

In the process of upgrading efficiency a question comes up as to what the ideal load conditions should be for replacement motors. A motor that is overloaded will have short life. In the opposite situation, a motor that is grossly oversized for the job it is asked to do is inefficient. Figure 6 shows a typical load versus efficiency curve for a 10 hp motor. This curve shows that in the upper half of the load range (50% - 100%) the efficiency stays fairly constant at a high level. At loads below 50% the efficiency drops dramatically. In most situations, once the motor is in operation and running, the load doesn't vary. This is especially true on heating, ventilating and air conditioning applications such as circulator pumps and air handling equipment. On other types of machinery, such as air compressors and machine tools, the load may cycle on and off, heavily loaded for some periods and lightly loaded at other times. Obviously on cycling loads it is important to size the motor so that it can handle the worst-case condition. However, on continuously loaded motors it is desirable to load motors at somewhere between 50 and 100% and most preferably in the range of 75 to 80%. By selecting a motor to be loaded in this range, high efficiency is available and motor life will be long. Also, by loading at somewhat less than 100% the motors can more easily tolerate such things as low voltage and high ambient temperatures that can occur simultaneously in summer. This approach will get somewhere closer to optimum efficiency while preserving motor life.

Existing Motor Efficiency Upgrades

In a commercial or large industrial situation the question comes up: "Should motors be replaced on a wholesale basis

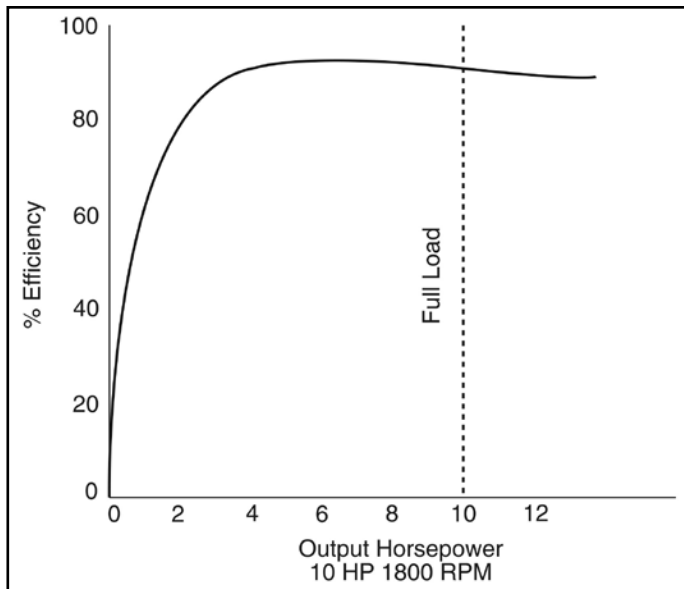

Figure 6 Typical load versus efficiency curve for a 10 HP motor; this curve shows that in the upper half of the load range (50% - 100%), the efficiency stays fairly constant at a high level.

throughout the plant, or selectively changed?" There is probably no hard rule for this, but here are some ideas. The wholesale change-out of all motors in a plant or commercial building generally cannot be justified on a cost basis. The reason for this is that some of the motors may be used only intermittently. Such things as test equipment, trash compactors and other similar situations support the case for not changing everything. There can also be other complications such as specialized motors found on some types of pumps and machine tools and old motors (where direct interchanges are not readily available). These fall into a cloudy area where change-out may not be justified.

Motors having the greatest potential for savings are those that run on an extended basis with near full load conditions. These are the logical candidates for any change-out program.

Utility Rebate Programs

A major breakthrough occurred a short time ago when court rulings were passed down so utilities could offer their customers financial help for conservation efforts. Prior to this change, utility companies were in a dilemma. If they financed and promoted conservation, the cost of the effort, personnel, equipment, etc., was an expense that reduced their sales and income. This set up a double disincentive for utility support of conservation measures.

Under the new rules utility money expended on conservation can be considered as a capital investment. Put differently, this means that financing the "buy back" of one kilowatt of capacity through conservation efforts is equivalent, for accounting purposes, to investing money to build a generating plant capable of generating that extra kilowatt. This new accounting approach has unleashed money that utilities are now willing (in some cases mandated) to invest in their customers' conservation efforts. A statement made by one utility indicated it was now possible to "buy back" a kilowatt of

capacity for roughly two-thirds of the cost of installing a new kilowatt of capacity. This new approach has turned a losing situation into a win-win situation for utilities and their customers.

The result of this has been a great flurry of activity in utility rebate programs to finance various types of conservation efforts. Again, as with individual initiatives on conservation, lighting has received major attention because it is easy to understand and large gains can be quickly achieved. Electric motors and variable speed drive systems now receive more attention because they represent the equipment that utilizes almost two-thirds of the power generated in the country.

Rebate programs usually handle motors in two different ways. One is a rebate allowed for standard motors that fail in service. This rebate recognizes that the expense involved to remove the old motor and install a new one is going to be necessary. In the "failed motor" programs the rebate is usually reduced, but is based on making it economically feasible to buy the premium efficiency motor to replace the old standard efficiency motor. In this case, only the extra cost difference for the purchase of the premium efficiency motor is recognized and offset.

A second approach is used for operating motors where a higher rebate incentive is offered to cover some of the cost of removal and replacement of an operable motor.

In the case of the operating motors, the rebate is aggressive enough to encourage wholesale change-out of operating motors. In this particular case, in addition to the rebate, the benefits of reduced energy costs are enjoyed by the customer — with few strings attached.

There are many other rebate programs based on different concepts including some where the utility invests in the conservation project and the resulting savings are shared by the utility and the customer over a period of time. Utility rebates in whatever form are a great incentive.

Perhaps the most important aspect is that utility rebates have aroused the commercial and industrial consumer's interest in conservation with motors.

In all rebate programs, minimum efficiency standards for the new motors must be met and usually there is a qualifier regarding the number of hours per year the motor must operate to be considered. In situations where rebate programs are offered, especially the aggressive ones, there can be few excuses for not using premium efficiency motors.

Getting Involved

The steps for getting involved in upgrading your motor efficiency situation should be as follows:

New equipment. When purchasing new equipment that will operate for substantial periods of time, ask for the premium efficiency motor option. Written into your request for quotation on air compressors, pumps, HVAC equipment, process machinery, etc., should be a specification that reads something like this:

Bidder should quote with his choice of standard induction motors and as an alternative, quote on the same machine

equipped with premium efficiency motors. Bidder will separate the incremental cost for the addition of the premium efficiency motor(s) and provide the nominal efficiencies of both the standard and the premium efficiency motors offered.

By using a specification similar to this, the ultimate owner of the equipment will be in the position to make logical decisions on new motors being installed in the facility. In most cases the incremental cost for a more energy efficient motor will be relatively small—especially when compared with the cost of the equipment it drives.

In-service failures. If a motor operates at a high level of load and runs reasonably long hours, replace it with a premium efficiency motor at time of failure.

Motors will normally last for many years if they are operated within reasonable limits and cared for properly. When they do fail it can be almost as expensive to get them repaired as it is to buy a new unit. Also, when a failure occurs, the labor to get the old motor removed and a rebuilt or new replacement in place is the same. In some cases labor can cost more than the motor. This makes time of failure the ideal time to make the change to get a more efficient motor in place.

Motor change-outs. Changing operating motors is the most difficult procedure to justify. It becomes feasible if the motors operate at high levels of load, have long hours of service, and especially if a utility rebate is involved.

If these three conditions are met, then you can start moving toward realizing bottom line savings available with premium efficiency motors.

Don't ignore the other possibilities. Some great energy saving possibilities, in addition to or in conjunction with premium efficiency motors, are the use of variable frequency drives. These are great energy savers, especially on variable torque loads such as centrifugal pumps, fans and blowers. On these types of loads the horsepower required varies as a cubic function of speed, and the energy varies almost in direct relationship to the horsepower.

Thus slowing a fan by 15% can yield energy savings of over 35%. Electronic variable frequency drives (VFDs) are extremely reliable and have become relatively inexpensive.

Two-speed motors also offer a simple and economical way to reduce energy costs. The speeds are not infinitely adjustable, as they are with adjustable frequency drives, but in those situations where that degree of adjustment is not necessary, the simplicity and economy of the two-speed motor and its control can yield great savings.

Don't ignore the opportunities with small motors. Many motor users in "light industry" and commercial facilities do not recognize the opportunity to save energy because they are of the opinion that their motors are "too small" to be viable candidates for efficiency upgrades. That thought process couldn't be more wrong! The degree of efficiency improvement on motors less than 10hp is substantially more than it is on larger units. For example, the efficiency improvement between a standard 3hp motor and a premium efficiency 3hp motor might be 7 or 8%.

Comparing it in the same way with a 100hp motor, the ef-

iciency gain might be only 2%. The net result is that small motors have the potential for paying off their differential cost faster than large motors.

Operating Costs and Savings

Rule of thumb. To get some perspective on the costs to operate motors and some possible savings, here is a good rule of thumb:

At 5 cents per kilowatt hour, it costs \$1 per horsepower per day to operate a motor at full load. (At 10 cents per kilowatt hour, this doubles to \$2 per day.) In some parts of the country, such as Hawaii and Alaska, energy costs run between 20 and 40 cents per kilowatt hour. This value can be ratioed to reflect less than full load or less than continuous operation, etc.

Consider a 100hp motor operating continuously in a 10 cents per kilowatt hour area. The annual cost of operation comes out to be approximately \$70,000. This can represent about 11 times the first cost of the motor. By spending an extra 30% (\$1,200) to get a premium efficiency unit (2.4% more efficient) the annual operating cost could be reduced by approximately \$1,800.

In the case of a small 3hp motor at 10 cents per kilowatt hour, the annual operating cost would be over \$2,300 per year and an extra 40% spent on the motor could reduce the operating cost by \$140 per year. In both cases mentioned, the extra cost of the motor would be paid off by energy savings in a few months.

When motors are running continuously at or near full load the initial cost of the motor is usually of little consequence compared with the annual operating cost.

Other Benefits

Because of their reduced losses, premium efficiency motors run at lower temperatures than equivalent standard motors. This results in longer insulation and lubricant life and less downtime. Inherent in their design is the ability to tolerate wider voltage variations and, when necessary, higher ambient temperatures.

An additional benefit is that by generating less waste heat in the space around the motor, building ventilation and/or air conditioning requirements are reduced. This can result in additional savings.

Summary

At the present time electric energy costs are high, but stable. Conservation has reduced the need for new generating facilities and the prices of fuels have been relatively constant. However, many nuclear plants are approaching the end of their useful life. As they are retired and their capacity has to be replaced, capital costs will certainly rise. Also, as the demand for clean-burning gas, liquid and solid fuels increases, the cost of these fuels is certain to rise. Thus it is important to seize every reasonable opportunity to conserve now. Adoption of premium efficiency three-phase induction motors is an easy and cost effective way to conserve.

OPERATING COST FORMULAS: MOTORS

$$\text{Kilowatt Hours} = \frac{\text{HP}^{**} \times .746 \times \text{Hours of Operation}}{\text{Motor Efficiency}}$$

** Average Load hp (May be lower than motor nameplate hp)

Useful Constants

Average hours per month = 730

Hours per year = 8,760

Average hours of darkness per year = 4,000

Approximate average hours per month (single shift operation) = 200

Annual Savings Formula

$$S = 0.746 \times \text{HP} \times C \times N \left[\frac{1}{E_s} - \frac{1}{E_{PE}} \right]$$

S = Dollars saved per year

HP = Horsepower required by load

C = Energy cost in dollars per kilowatt hour

N = Annual running hours

E_s = Efficiency of standard motor (decimal)

E_{PE} = Efficiency of premium motor (decimal)

General Formula — All Loads

$$\text{Kilowatt Hours} = \frac{\text{Watts} \times \text{Hours of Operation}}{1000}$$

Approximate Operating Cost = Kilowatt Hours × Average Cost per Kilowatt Hour

(Does not include power factor penalty or demand charges which may be applicable in some areas.)



PREMIUM EFFICIENCY MOTORS – (Q & A)

(Please note that while current regulations for the U.S. only allow production of premium efficient three-phase motors in the 1-500hp range, the information in this article remains relevant when comparing to older motors that may be installed in plant equipment.)

In spite of the great money and energy saving potential available by using premium efficiency motors, it is surprising that many motor users are not specifying these motors. Some reasons for not using them are misunderstandings about the energy saving potential. The following information is presented in a question and answer format to address some of the myths and questions related to premium efficiency motors.

Can I save money even when I only have relatively small motors in my plant?

The energy saving potential of small premium efficiency motors is actually greater percentage-wise than the savings on large motors. The reason is that on small motors, the percentage difference in efficiency between the standard motor and the premium efficiency motor is actually much greater than it is on larger motors. For example, the difference between a standard motor at 3 hp and the premium efficiency motor could easily be 9 or more percentage points. Compare this to a 100 hp motor where the difference between the standard and premium efficiency motors might only be 2%.

Do my motors have to be fully loaded to realize the savings available in premium efficiency motors?

It is usually advantageous to have motors loaded to more than 50% of rated load for optimum efficiency. Thus, it is usually best to resize a motor at the same time it is upgraded to premium efficiency. However, even if this is not done and the motor is oversized, there is still substantial savings to be gained by utilizing a premium efficiency motor. For example, at 25% of rated load, the difference in efficiency between a standard motor and a premium efficiency motor (of 10 hp) would be 89.5% vs. 92.4%. Thus, the premium efficiency motor is still substantially better even at low load levels than a non-premium efficiency motor. Even without resizing, a substantial efficiency improvement can be made.

How much more do premium efficiency motors cost?

Generally, premium efficiency motors cost 20 to 30% more depending upon the size and speed of the motor.

Why do premium efficiency motors cost more than standard motors?

Premium efficiency motors use more and better materials. For example, the lamination material is a higher grade, higher cost steel. In addition, the rotor and stator are generally longer in a premium efficiency motor than in a standard motor. The laminations are thinner compared to a standard efficiency motor. This means there are more laminations. In addition, the lamination slots are larger so more copper can be used in the windings. Finally, premium efficiency mo-

tors are manufactured in smaller production lots which also tends to make them more expensive.

If premium efficiency motors can save lots of money, why don't more people use them?

This is a tough question but is probably related to the fact that many people buy on first cost rather than considering operating costs. Also, there seems to be skepticism about manufacturer's claims on performance of these motors. Many power users that have been very active in other energy conserving programs such as lighting, insulating etc., have ignored the energy-saving potential of premium efficiency motors.

Why can't motor manufacturers make it more obvious that we are going to save money with these motors?

Unlike light bulbs that are sold by wattage consumption (input), electric motors are sold by horsepower (output). Thus, subtle differences in efficiency usually appear in the fine print and get overlooked. For example, it is obvious when you buy a 34 watt fluorescent light bulb to replace a 40 watt bulb, that some savings are available. It is less obvious when you buy a 5 hp motor of one design versus a 5 hp motor of a premium efficiency design, that there will be savings on the electric bill. Also, the vagaries of electric bills and the complications involved in the electric billing process with demand charges, energy charges, fuel cost adjustments and occasionally, power factor penalties, create enough confusion so savings are not obvious. But they exist.

How can I evaluate the dollar savings on premium efficiency motors?

There are three items needed to conduct an evaluation. First and most important, is the average cost per kilowatt hour of electricity. The simplest and most direct way to get this is to take the bottom line cost on a monthly electric bill and divide it by the total kilowatt hours used. This gives a net cost per kilowatt hour which is generally the best cost to use in evaluating energy saving equipment. The reason this works is that equipment designed for better efficiency will in general, reduce the demand, kilowatt hours, and fuel cost adjustments in equal proportions. Thus, using the average cost per kilowatt hour is the easiest way of making an evaluation. Next would be the hp size of the motor that is operating and, finally, the number of hours per month or year that it operates. With these three items and the efficiency difference between one motor and the other, it is easy to figure the cost savings. *(The formulas for doing this appear at the end of this chapter.)*

How quickly will these motors pay for themselves?

This is impossible to answer without all the facts from the previous question but motors operating twenty-four hours a day at or near full load, can be expected to pay for themselves in less than two years. The difference between a standard motor's cost and a premium efficiency motor's cost can be paid off in a few months. One thing is certain: regardless of the operating details, premium efficiency motors will always save money versus lower efficiency units and savings go on for as long as the motor is in operation. In many cases this could

be twenty to thirty years. Also, as power costs rise, savings will rise in proportion. The old rule of "pay me now or pay me later" has a corollary when applied to premium efficiency motors which might be "pay a little more now and save some now and more later."

Are there any other advantages to premium efficiency motors?

Yes, because of the superior designs and better materials used in them, premium efficiency motors tend to run at lower operating temperatures resulting in longer life for lubricants, bearings and motor insulation. Another advantage is that, by generating less waste and less heat in the space around the motor, air conditioning and ventilation requirements are reduced, resulting in additional energy savings.

What is the best way to take advantage of premium efficiency savings potential?

Specify motors that meet the NEMA Premium efficiency requirements on new equipment and as replacement units for failures. Some judgement should be used on blanket specifications. For example, it may be impractical to try to specify premium efficiency motors for single phase, fractional horsepower, and specialized motor requirements or where the motor is an integral part of the equipment. Also, on motor installations where infrequent service is required, the extra cost may not be justified. Examples of this would be trash compactors, batch mixers and other equipment that only operate for short periods of time. It might also be difficult to justify the added cost of premium efficiency motors on equipment that operates on a seasonal basis, especially if the season is short.

In summary, it is important to seize the opportunity to move into premium efficiency motor use as soon as possible. **PTE**

Continental

CELEBRATES 50TH ANNIVERSARY FOR MARYSVILLE, OHIO PLANT

Continental's Marysville, Ohio, plant, its premier North American manufacturing facility for conveyor belting products, celebrated its 50th anniversary recently.

"We are proud to share in this golden jubilee celebration of a highly versatile and productive facility," said Jim Hill, ContiTech CEO for the North America Region. "This plant has made belting for facilities all over the world, and we are confident that it will continue that process into the future."



The 375,000-sq.-ft. facility rests on a 110-acre plot of land about 30 miles northwest of Columbus, Ohio. The plant shipped its first conveyor belt on August 31, 1967. Total employment at the location is 292. Marysville primarily produces fabric and steel conveyor belting to service many industries from mining to power generation to construction and wood products. It has the capability to produce the world's strongest conveyor belt, ST10000, which is a steel cord construction. Continental ContiTech acquired the plant in January 2015.

"We are all now part of an organization that will enable us to strategically position ourselves to provide dynamic growth for all of the markets in which we compete in the North America region," said Hill. "We continue to grow our customer network and provide the seamless distribution of our products with our focus on North America." (www.contitech.us)

Siemens and HP Inc.

PARTNER ON 3D PRINTING SOFTWARE SOLUTIONS

Building on a longstanding partnership, HP Inc. and Siemens are accelerating 3D printing for industrial production through the creation of a new HP-certified Additive Manufacturing (AM) software module from Siemens. The new software module, *Siemens NX AM* for HP Multi Jet Fusion, is now available from Siemens PLM Software as an extension to Siemens' end-to-end design-to-production solution for additive manufacturing. The *NX* software module will allow customers to develop and manage parts in a single software environment for their HP 3D Printing projects, avoid costly and time-consuming data conversions and third-party tools, and improve their overall design-to-finished-part workflow efficiency. Siemens and HP are also aligning future technology roadmaps to enable designers and engineers to completely reimagine products to take advantage of HP's 3D printing capabilities, escape the limitations of conventional manufacturing, and cost-effectively produce new products at faster speeds. This in turn will lead to greatly expanded opportunities for the industrial 3D printing of innovative designs.

Siemens' new software module will enable *NX* customers to combine design, optimization, simulation, preparation of print jobs, and inspection processes for HP Multi Jet Fusion 3D printed parts in a managed environment. Users can now load multiple 3D part models into *NX*, and auto nest and submit them to an HP 3D printer, all in a single environment and with a minimum of steps. The *NX* and Multi Jet Fusion

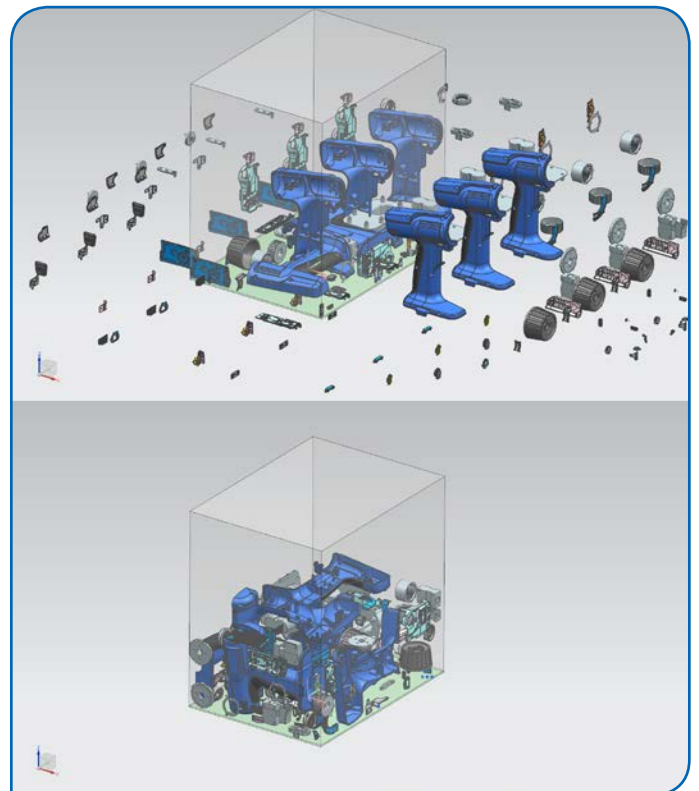

3D nesting in Siemens NX allows users to maximize the number of prints that can be executed within the build volume of the HP Multi Jet Fusion printer (courtesy of Siemens).

integration also eliminates the need for data conversion between software applications or process steps and, in the future, is intended to allow unprecedented control, including material characteristics down to the individual voxel-level. This will result in the ability to print parts with variable textures, density, strength and friction, as well as thermal, electrical, and conductivity characteristics.

“HP and Siemens are bringing together the best in design and manufacturing workflow software for the best in 3D printing, unleashing a wave of new product possibilities with the speed, quality, and economics required for the modern digital industrial era,” said Michelle Bockman, global head of 3D Printing Commercial Expansion and Development, HP Inc. “We look forward to collaborating with Siemens to continually raise the industry bar on what’s possible for customers with the voxel-level design capabilities of our Multi Jet Fusion 3D printing solutions.”

Siemens and HP share the objective to industrialize additive manufacturing. HP’s award-winning Multi Jet Fusion 3D printing solution is a production-ready commercial 3D printing system that delivers superior quality physical parts up to 10 times faster and at half the cost of current 3D printing systems. With Siemens’ comprehensive offering covering product lifecycle management (PLM) and electronic design automation (EDA) software, integrated automation and manufacturing operations management, combined with HP’s 3D printing solutions, manufacturers have the tools to establish additive manufacturing as a truly industrial production process. Both companies continue to work together and with other industry leaders to create an important ecosystem of partners who can help realize the goal of additive manufacturing as a viable production alternative.

“At Siemens, we see additive manufacturing as a transformative digital force that is empowering companies to reimagine their products and factories to achieve new levels of business performance,” said Zvi Feuer, senior vice president of Manufacturing Engineering Software, Siemens PLM Software. “Deepening our partnership with HP and driving their innovative 3D printing technology is especially important as companies look to increase speed to market, differentiate on product performance, simplify production and supply chain operations, and implement new business models. As products become more complex and individualized, we look forward to the next frontier of 3D printed parts with multiple materials, tunable mechanical properties and integrated electronics.” (www.siemens.com/plm)

Rocky Mountain Technologies

State of the Art Custom Design and Consulting Services

Where Innovation and Solutions Meet

- We Deliver Custom Motors and Drives
- We Design Your Custom Motors and Drives
- We Assist with In-House Design and Consulting
- Prototyping, Pre-Production, Product Performance
- Strategic Partners Volume Sourcing



(406) 552-4260

sales@rockymountaintechnologies.com

Rocky Mountain Technologies, P.O. Box 210, Basin, MT 59631

BEYTA GEAR SERVICE

**PUTTING
A LIFETIME**

OF

**GEAR
DESIGN**

EXPERIENCE

TO WORK FOR YOU

- Reverse engineering
- Gearbox upgrades
- Custom gearbox design
- Specification development
- Project management
- Vendor qualification
- Design reviews
- Bid evaluations
- Tooling design
- Customized gear training
- Equipment evaluation
- Custom machine design

Charles D. Schultz
chuck@beytagear.com
[630] 209-1652

www.beytagear.com

Forest City Gear

WELCOMES PROCESS ENGINEER

Forest City Gear has added **Brian Gustafson** to its growing team of process engineers, with responsibility for creating the routings, machine instructions and process drawings that are critical to the success of every precision gear manufacturing project.

Gustafson has 15 years of diversified design and manufacturing engineering experience, ranging from CNC machining and programming to overseeing the shop floor operations of a gear production facility. He has a B.S. degree in Manufacturing Engineering Technology from Bradley University.

Gustafson's extensive manufacturing background made him an ideal candidate for the position, says Forest City Gear President Wendy Young. "His deep understanding of gear manufacturing processes gives him special insight into the needs our customers. He will be an important asset to help ensure that projects flow efficiently from order entry, to scheduling to shop floor production."

For over 60 years Roscoe, IL based, family-owned Forest City Gear has been one of the gear industry's leading sources for the development, manufacture and inspection of the highest quality gears, for use in applications that range from medical devices to motorcycles, airplanes to automation, even including the Mars Curiosity Rover. (www.forest-citygear.com)



Furthermore, through an existing exclusivity agreement with a leading supplier of steering actuation controls, Sheppard will be able to offer a compact, cost-effective, breakthrough technological solution that enables active steering control for commercial vehicle manufacturers in North America.

"This acquisition represents another key milestone as WABCO advances toward enabling self-driving commercial vehicles," said Jacques Esculier, WABCO chairman and chief executive officer. "We have a clear line of sight on the fundamental technologies — such as active steering, active braking, electronic stability control and other advanced driver assistance systems — which will enable significant intermediary steps on our industry's path to realize fully autonomous driving."

Full dynamic control of commercial vehicles — lateral and longitudinal — is necessary to progressively achieve the industry's vision of autonomous driving. The acquisition of Sheppard is a key capability toward providing lateral control through active steering, which is a cornerstone that complements WABCO's leading technologies in longitudinal control through active braking, stability and suspension controls.

Sheppard has been leveraging its technologies to develop products specially adapted for regions outside North America. Sheppard already manufactures and sells these products through a joint venture in China and will use WABCO's global network to reach into other regions.

"We are excited at the prospect of joining WABCO," said Oliver Hoar, president and chief executive officer, Sheppard. "Our leading technologies will be fully integrated into the strategy of this industry leader on a journey to create opportunities for further growth in North America and globally." (www.wabco-auto.com)

WABCO

ACQUIRES SHEPPARD

WABCO Holdings Inc., a global supplier of technologies and services that improve the safety, efficiency and connectivity of commercial vehicles, recently announced that it has signed an agreement to acquire privately held RH Sheppard Co., Inc., a key supplier of commercial vehicle technologies, including industry-leading vehicle steering capabilities, headquartered in Hanover, Pennsylvania.

The transaction is subject to customary U.S. regulatory clearance and it is expected to close by the end of the third quarter 2017. WABCO's purchase price is \$145 million, subject to customary adjustments. Sheppard had sales of \$130 million in 2016.

A key tier-one supplier in North America, Sheppard offers a suite of power-steering gears that has set the industry standard for heavy-duty commercial and specialty vehicles. Employing more than 900 persons, Sheppard also provides precision engineered engine pumps and state-of-the-art remanufacturing services. In addition, the company is vertically integrated with its own manufacturing and advanced foundry capabilities, which WABCO expects to use for some of its products.

Magnet Applications

INTRODUCES SALES MANAGER

Magnet Applications, Inc., a provider of compression bonded magnets, injection molded magnets and magnetic technical assemblies to the automotive, medical, defense and aerospace industries, recently announced that Jim Rundo has been hired as the company's new sales manager. As sales manager, Rundo will lead the company's sales team and oversee sales strategies throughout North America and targeted export markets.

Rundo assumes the role, which has been held by magnetics industry veteran, Mike Miller, for 25 years. Miller has announced his retirement effective February 2018. "Over his long career with Magnet Applications, Mike has built an unrivaled reputation for his passion and devotion to finding magnetic solutions for our customers," commented Don Lindstrom, general manager, Magnet Applications, Inc. "His leadership has played a critical role in our growth over the last several years. We are thrilled, however, that Mike will be working with Jim over the next several months to ensure a seamless transition to our customers and operations."

Regarding Rundo, Lindstrom commented, "Jim will be an outstanding addition to our management team, as he brings

a deep blend of industrial business development, market growth strategies and customer service experience, including in the power magnetic solution industry. I know he will work tirelessly with our sales team to broaden our reach while serving the needs of our current customers.”

Rundo was formerly new business development manager for AirBorn, Inc., a leading designer and manufacturer of specialized connectors and electronic components. Prior to AirBorn, Inc., he was sales manager for the Schaffner Group, a developer of custom power magnetic solutions for single and multi-phase power applications.

He holds a bachelor of science degree in electrical engineering from Cleveland State University and an MBA from Regis University.

“With the explosion of industry advancements in automotive, medical and defense, Magnet Applications has a great opportunity to advance its market position. I’m excited to be working at a company that’s truly on the move and eager to work with sales and marketing, roll up our sleeves and push the company forward,” said Rundo.

(www.magnetapplications.com)

IDC-USA

ADDS DIRECTOR OF MEMBER SERVICES

IDC-USA is very pleased to announce the addition of **Bill Jacobs** as director of member services. Jacobs is a graduate of Xavier University with a bachelor’s degree in management and marketing. He has spent his entire career of 30-plus years working in the bearing and power transmission industry. His responsibilities have included many management roles including marketing, ERP integration, and distribution center operations.



“Bill will be a great asset to IDC-USA not only because of his product and industry expertise, but also for his system integration knowledge and data management skills. Bill will help us streamline our processes going forward, and he will help enhance our data management systems as we continue to expand our IDC Marketplace initiative,” stated George Graham, president and CEO of IDC-USA.

“I am eager to utilize my experience within industrial distribution at IDC-USA. I feel this is the ideal environment to apply my accumulated knowledge to assist in process improvements wherever possible and practical. I look forward to continuing the dedication to customer needs that sets independent distributors apart in the industry. My ultimate goal is to help our members close more sales more profitably. We will work in every way possible to streamline the supply chain to the benefit of our members and suppliers,” commented Jacobs.

Jacobs’ primary focus will be assuming responsibility for the Member Services group and will also become more in-

involved with IDC Marketplace and warehousing operations over time. “Bill will be a great addition in our continuous quest to add value to our Owner-Distributors and our Preferred Supplier Partners,” Graham said. (www.IDC-USA.com)

IPS

OPENS NEW WAREHOUSE AND FIELD OFFICE IN IOWA

Integrated Power Services (IPS), a North American leader in the service and repair of electric motors, generators and mechanical power transmission components, has expanded its operations with a new warehouse and field service office in Des Moines, IA. The facility addition brings the IPS service network to 28 locations across North America.

The new IPS Des Moines facility is located at 4667 121st Street and offers managed storage of critical rotating and industrial assets, distribution and field services. Featuring a climate-controlled environment, the location will perform scheduled mechanical and electrical testing, distribute several OEM-partner products, as well as retain inventory of new critical replacement motors. The Des Moines facility will link with the Litchfield, MN and Cleveland, OH repair centers to bring low, medium and high voltage motor and generator repair as well as field service capability to customers in the IA, NE, KS and MO regions.



“The addition of the Des Moines Warehouse and Field Office represents IPS’s commitment to bringing in-shop repair, field service and distribution to a geography where current and new customers have needs that can be supported by our comprehensive network of locations and industry-leading engineering services,” said John Zuleger, IPS president and CEO. (www.ips.us)

October 31–November 3–PTC Asia 2017 Shanghai New International Expo Center. PTC Asia is a leading trade fair for power transmission and control and fluid technology as well as bearings, motors, linear and sealing technologies. The slogan for the 2017 show is “Driven to be Smart,” with forums and discussions on Industry 4.0, predictive maintenance, automotive, marine and additional engineering topics. It is co-located with six other industrial shows including CeMAT Asia, ComVac Asia, Apex Asia, Heavy Machinery Asia, Cold Chain Asia and Industrial Supply Asia. The shows are organized by Hannover Milano Fairs Shanghai Ltd., a subsidiary of Deutsche Messe. For more information, visit www.ptc-asia.com.

November 3–9–IMECE 2017 Tampa Convention Center, Tampa, Florida. ASME’s International Mechanical Engineering Congress and Exposition is the largest interdisciplinary mechanical engineering conference in the world. IMECE plays a significant role in stimulating innovation from basic discovery to translational application. It fosters new collaborations that engage stakeholders and partners not only from academia, but also from national laboratories, industry, research settings, and funding bodies. The event features 20+ tracks, 240+ mechanical engineering topics, daily plenary sessions, industrial presentations, an Honors Assembly program and more. For additional information, visit www.asmeconferences.org.

November 14–16–AGMA 2017 Detailed Gear Design (Beyond Simple Service Factors) Dallas, Texas. Learn how to improve gear designs and gain new insight into concepts presented through illustrations and demonstrations. Explore all factors that go into good gear design from life cycle, load, torque, tooth optimization, and evaluating consequences. Pre-requisite: Students should have a good understanding of basic gear theory and nomenclature: Online Workforce Education: Fundamentals of Gearing or Fundamentals of Gear Design and Analysis. Gear engineers, gear designers, application engineers, people who are responsible for interpreting gear designs, technicians and managers that want to better understand all aspects of gear design should attend. Raymond Drago is the course instructor. For more information, visit www.agma.org.

November 15–16–Rockwell Automation Fair 2017 Houston, Texas. Hands-on labs, technical sessions and forums highlight the 2017 event. See the latest automation technology and solutions in action at over 150 exhibits and 110 forums. Subjects include automotive, chemicals, food and beverages, life sciences, mining, energy, and more. The 2017 event will showcase nine forums. Each forum will feature representatives and experts from a variety of companies. They will present their experiences and applications of the latest automation technologies used to increase their productivity and improve the efficiency of their business. For more information, visit www.rockwellautomation.com.

December 4–7–CTI Symposium 2017 Germany The International CTI Symposium in Berlin, Germany and its flanking specialist exhibition is the international industry event in Europe for people seeking the latest information on developments in automotive transmissions and drives for passenger cars and commercial vehicles. Here, you can meet experts for Europe, America and Asia, as well as see extensive OEM reports and delegates from 28 countries. Over 33 percent of participants come from non-German speaking countries, making the CTI Symposium one of the most international industry meetings in Europe. In 2016, it was attended by over 2,500 participants and 230 exhibitors. For more information, visit www.transmission-symposium.com/en/.

December 5–7–Power-Gen International 2017 Las Vegas Convention Center, Las Vegas Nevada. Power-Gen International provides comprehensive coverage of the trends, technologies and issues facing the generation sector. More than 1,400 companies from all sectors of the industry exhibit each year to benefit from the exposure to more than 20,000 attendees. Displaying a wide variety of products and services, Power-Gen International represents a horizontal look at the industry with key emphasis on new solutions and innovations for the future. In 2017, Power-Gen is going back to its roots and will cover ALL forms of power generation broken up into 14 tracks. Nearly 300 industry experts from all over the world will present new solutions and innovations for the future. Full conference attendees will also earn 10 PDH credit hours. Conference sessions include energy storage, digital power plant, material handling, business trends, nuclear power and more. For more information, visit www.power-gen.com.

December 6–8–AGMA 2017 Gear Failure Analysis San Francisco, CA. Learn the skills necessary to diagnose gear failures and prescribe remedies. Study six classes of gear tooth failure: overload, bending fatigue hertzian fatigue, wear, scuffing, and cracking. Examine each failure mode as illustrated by color slides and field samples because of the magnification inherent in slide projection. Engage in group activity and discussion in a hands-on practical exercise using field samples and a case study. Recommended preparation for Gear Failure Analysis is the archived AGMA webinar, *Metallurgy of Gear Materials*, presented by Dr. Phil Terry. This webinar is excellent especially for those with no training in metallurgy. The webinar is available by download free for members and \$159 for non-members. Gear engineers, users, researchers, maintenance technicians, lubricant experts, and managers should attend. For more information, visit www.agma.org.

Power Transmission Engineering

Power Transmission Engineering's Statement of Ownership, Management and Circulation

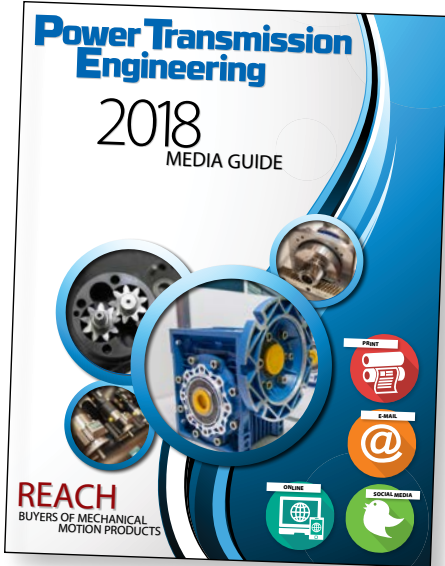

Additional information about *Power Transmission Engineering* and its audience can be found in our 2018 media kit. Download it at www.powertransmission.com/adinfo.htm

1. Publication Title		2. Publication Number		3. Filing Date	
POWER TRANSMISSION ENGINEERING		2	3	3	1
4. Issue Frequency		5. Number of Issues Published Annually		6. Annual Subscription Price (\$ if any)	
Monthly except January, May, July & November		8		\$ 56.00	
7. Complete Mailing Address of Known Office of Publication (Not printer) (Street, city, county, state, and ZIP+4®)					
1840 Jarvis Ave., Elk Grove Village, Cook County, IL 60008-2440					
8. Complete Mailing Address of Headquarters or General Business Office of Publisher (Not printer)					
1840 Jarvis Ave., Elk Grove Village, Cook County, IL 60008-2440					
9. Full Names and Complete Mailing Addresses of Publisher, Editor, and Managing Editor (Do not leave blank)					
Publisher (Name and complete mailing address)					
Michael Goldstein 1840 Jarvis Ave., Elk Grove Village, Cook County, IL 60008-2440					
Editor (Name and complete mailing address)					
Michael Goldstein 1840 Jarvis Ave., Elk Grove Village, Cook County, IL 60008-2440					
Managing Editor (Name and complete mailing address)					
Michael Goldstein 1840 Jarvis Ave., Elk Grove Village, Cook County, IL 60008-2440					
10. Owner (Do not leave blank. If the publication is owned by a corporation, give the name and address of the corporation immediately followed by the names and addresses of all stockholders owning or holding 1 percent or more of the total amount of stock. If not owned by a corporation, give the names and addresses of the individual owners. If owned by a partnership or other unincorporated firm, give its name and address as well as those of each individual owner. If the publication is published by a nonprofit organization, give its name and address.)					
Full Name		Complete Mailing Address			
Michael Goldstein		1840 Jarvis Ave. Elk Grove Village, Cook County, IL 60008-2440			
11. Known Bondholders, Mortgagees, and Other Security Holders Owning or Holding 1 Percent or More of Total Amount of Bonds, Mortgages, or Other Securities. If none, check box <input checked="" type="checkbox"/> None					
Full Name		Complete Mailing Address			
12. Tax Status (For completion by nonprofit organizations authorized to mail at nonprofit rates) (Check one)					
<input type="checkbox"/> Has Not Changed During Preceding 12 Months					
<input type="checkbox"/> Has Changed During Preceding 12 Months (Publisher must submit explanation of change with this statement.)					

PS Form 3526-R, July 2014 (Page 1 of 4) (See instructions page 4) PSN: 7530-09-000-8935 PRIVACY NOTICE: See our privacy policy on www.usps.com.

13. Publication Title		14. Issue Date for Circulation Data Below	
POWER TRANSMISSION ENGINEERING		AUGUST 2017	
15. Extent and Nature of Circulation		Average No. Copies Each Issue During Preceding 12 Months	No. Copies of Single Issue Published Nearest to Filing Date
a. Total Number of Copies (Net press run)		15,144	15,794
b. Legitimate Paid and/or Requested Distribution (By mail and outside the mail)	(1) Outside County Paid/Requested Mail Subscriptions stated on PS Form 3541. (Include direct written request from recipient, telemarketing, and internet requests from recipient, paid subscriptions including nominal rate subscriptions, employer requests, advertiser's proof copies, and exchange copies.)	7,211	6,396
	(2) In-County Paid/Requested Mail Subscriptions stated on PS Form 3541. (Include direct written request from recipient, telemarketing, and internet requests from recipient, paid subscriptions including nominal rate subscriptions, employer requests, advertiser's proof copies, and exchange copies.)	-	-
	(3) Sales Through Dealers and Carriers, Street Vendors, Counter Sales, and Other Paid or Requested Distribution Outside USPS®	313	287
	(4) Requested Copies Distributed by Other Mail Classes Through the USPS (e.g., First-Class Mail®)	-	-
c. Total Paid and/or Requested Circulation (Sum of 15b (1), (2), (3), and (4))		7,524	6,683
d. Non-requested Distribution (By mail and outside the mail)	(1) Outside County Nonrequested Copies Stated on PS Form 3541 (include sample copies, requests over 3 years old, requests induced by a premium, bulk sales and requests including association requests, names obtained from business directories, lists, and other sources)	6,829	8,543
	(2) In-County Nonrequested Copies Stated on PS Form 3541 (include sample copies, requests over 3 years old, requests induced by a premium, bulk sales and requests including association requests, names obtained from business directories, lists, and other sources)	-	-
	(3) Nonrequested Copies Distributed Through the USPS by Other Classes of Mail (e.g., First-Class Mail, nonrequestor copies mailed in excess of 10% limit mailed at Standard Mail® or Package Services rates)	-	-
	(4) Nonrequested Copies Distributed Outside the Mail (Include pickup stands, trade shows, showrooms, and other sources)	191	238
e. Total Nonrequested Distribution (Sum of 15d (1), (2), (3), and (4))		7,020	8,781
f. Total Distribution (Sum of 15c and e)		14,544	15,464
g. Copies not Distributed (See Instructions to Publishers #4, (page #3))		600	330
h. Total (Sum of 15f and g)		15,144	15,794
i. Percent Paid and/or Requested Circulation (15c divided by 15f times 100)		51.7%	43.2%

* If you are claiming electronic copies, go to line 16 on page 3. If you are not claiming electronic copies, skip to line 17 on page 3.

PS Form 3526-R, July 2014 (Page 2 of 4)

16. Electronic Copy Circulation		Average No. Copies Each Issue During Preceding 12 Months	No. Copies of Single Issue Published Nearest to Filing Date
a. Requested and Paid Electronic Copies		3,427	3,181
b. Total Requested and Paid Print Copies (Line 15c) + Requested/Paid Electronic Copies (Line 16a)		10,951	9,864
c. Total Requested Copy Distribution (Line 15f) + Requested/Paid Electronic Copies (Line 16a)		17,971	18,645
d. Percent Paid and/or Requested Circulation (Both Print & Electronic Copies) (16b divided by 15c x 100)		60.9%	52.9%
<input checked="" type="checkbox"/> I certify that 60% of all my distributed copies (electronic and print) are legitimate requests or paid copies.			
17. Publication of Statement of Ownership for a Requester Publication is required and will be printed in the October 2017 issue of this publication.			
18. Signature and Title of Editor, Publisher, Business Manager, or Owner		Date	
<i>Michael Goldstein</i> Publisher		9/30/17	
I certify that all information furnished on this form is true and complete. I understand that anyone who furnishes false or misleading information on this form or who omits material or information requested on the form may be subject to criminal sanctions (including fines and imprisonment) and/or civil sanctions (including civil penalties).			

PS Form 3526-R, July 2014 (Page 3 of 4) PRIVACY NOTICE: See our privacy policy on www.usps.com.

CALL FOR PAPERS!

Are you sitting on an idea for a technical paper but wondering where to present it? Do you have one already written, sitting on your desk, gathering machine dust?

How about *Power Transmission Engineering*? We are always looking for gearing- and power transmission component-relevant technical papers for publication in the magazine and in its digital version. Having your work appear in *Power Transmission Engineering* guarantees you an audience of the most experienced and discriminating industry players. You say your work has not been peer-reviewed? Not a problem, as we are lucky—and thankful—to have on-hand some of the most experienced and brilliant minds in the industry—our technical editors. So if your work “passes muster” and is published, you’ll know you were reviewed by the best—and most demanding.

Chances are you’ll be creating the paper under the auspices of the company for whom you work or own, or for one of the various industry-relevant associations. That means they as well will bask in the reflected glory that accrues with publication in *Power Transmission Engineering*.

For publication guidelines and more information, please contact Jack McGuinn at jmcguinn@powertransmission.com.

Andantex USA Inc.

Page 15
www.andantex.com

B&R Machine and Gear

Page 36
www.brgear.com

Baldor

Page 7
www.baldor.com

Beyta Gear Service

Page 57
www.beytagear.com

Brother International

Inside Front Cover
www.brothergearmotors.com

Circle Gear

Page 13
www.circlegear.com

Cleveland Gear Co.

Page 37
www.clevelandgear.com

CTI — Car Training Institute

Page 9
www.transmission-symposium.com/en

Diequa Corp.

Pages 19, 37
www.diequa.com

FACT North America LLC

Page 21
www.rototime.com

Lafert North America

Page 17
www.lafertna.com

Lubriplate

Page 3
www.lubriplate.com

McInnes Rolled Rings

Page 10
www.mcinnesorledrings.com

Miki Pulley

Page 12
www.mikipulley-us.com

Molon Motor and Coil

Page 16
www.molon.com

Napoleon Engineering Services

Page 14
nesbearings.com

Nordex Inc.

Pages 18, 36
www.nordex.com

QA1 Precision Products

Page 2
www.qa1.net

R+W America

Page 11
www.rw-america.com

Rocky Mountain Technologies

Page 57
www.rockymountaintechnologies.com

Schaeffler Group

Back Outside Cover
www.schaeffler.us

SEW-Eurodrive

Inside Back Cover
www.seweurodrive.com

Suhner Manufacturing

Page 2
www.suhner.com

Turner Uni-Drive

Page 36
www.turnerunidrive.com

Zero-Max

Page 5
www.zero-max.com

Power Transmission Engineering



Power Transmission Engineering is Your KEY to understanding Gears, Gear Drives, Bearings, Motors, Clutches, Couplings, Brakes, and other Power Transmission Components.

Unlock your FREE subscription by filling out this form.

FREE SUBSCRIPTION

1 **YES** I want to receive/continue to receive **Power Transmission Engineering** FREE!
 No thank you.

Name: _____ JobTitle/Position: _____
(print)

Signature _____ Date: _____
(required)

2 → E-mail _____
(So we can notify you when the online edition is available)

 **SAVE a TREE!**
 I ONLY want the digital edition (e-mail required)

3 → Please update your contact information or attach you business card here. (No Staples)

Company Name: _____
Address: _____

City: _____
State/Province: _____ ZIP+4/Postal Code: _____
Country: _____
Telephone: _____ Fax: _____
E-mail: _____
Website: _____

5 → My company's principal product or service is: _____

6 → What is your primary job function responsibility? (Check one)

<input type="checkbox"/> Corporate Management (1)	<input type="checkbox"/> Quality Control (7)
<input type="checkbox"/> Plant Engineering (2)	<input type="checkbox"/> Factory Automation (8)
<input type="checkbox"/> Design Engineering (3)	<input type="checkbox"/> Maintenance (9)
<input type="checkbox"/> Marketing & Sales (4)	<input type="checkbox"/> Other (10)
<input type="checkbox"/> Manufacturing Engineering (5)	
<input type="checkbox"/> Purchasing (6)	

Is there a colleague within your company that might benefit from having their own copy of **Power Transmission Engineering** magazine?

Name: _____
Title: _____

4 → How is THIS LOCATION involved with power transmission products? (Check all that apply)

WE MAKE power transmission products (10)
 WE BUY power transmission products (12)
 WE SELL power transmission products (Distributors, sales reps. etc.) (14)
 WE DESIGN products with power transmission components in them. (16)
 Other (please describe) (15) _____

DIGITAL SUBSCRIPTIONS

YES, I want to be notified each issue when *Power Transmission Engineering* is available online

YES, I would like to receive *Power Transmission Engineering's* monthly e-mail newsletter

YES, I would like to receive *Power Transmission Engineering's* twice monthly e-mail Product Alerts

YES, I would like to receive 3rd-party e-mails from *Power Transmission Engineering's* advertisers and partners

YES, I would like to receive subscription renewal notices by e-mail

No, I do not wish to be contacted by e-mail.

FAX TO 1-847-437-6618 or
VISIT US ONLINE AT
www.powertransmission.com/subscribe.htm

The Long and Short of It

10,000 Year Clock Needs Bearings that Run for 350 Million Cycles

Matthew Jaster, Senior Editor

In the future, a determined hiker will journey to a mountain in Western Texas and find the entrance to a remarkable engineering project.

Deep inside the mountain lies a clock—hundreds of feet tall—designed to run for a span of 10,000 years.

The 10,000 Year Clock project was conceived by Danny Hillis, a polymath inventor, computer engineer and designer that wanted to inform and enlighten people in the future about the manufacturing ingenuity of our past.

The goal was to build a clock in the middle of a mountain that would tick once a year, the century hand would advance once every 100 years and the cuckoo would show up on the millennium. Hillis and Stewart Brand launched a non-profit organization—the Long Now Foundation—to begin various prototypes of a clock that would essentially run for 10,000 years.

One of the key engineering hurdles in the project was determining what kind of bearings would be able to outlast most metals, rotate at very low speeds and require no lubrication. The Long Now Foundation basically needed a bearing that would work through 350 million cycles. The logical choice was ceramic bearings.

“Boca Bearings had a full range of bearings and sent some samples to the Long Now Foundation,” said Jason Flanzbaum, president at Boca Bearings. “Testing those samples revealed that those bearings were the only ones that could do 350 million cycles without lubrication, with high corrosion resistance and unparalleled working life and high efficiency.”

In order to accomplish this, Boca developed several cycle-testing setups to simulate the working life that the gears, springs and bearings will experience for 10,000 years.

“The Long Now Foundation decided to use ceramics because during the cycle testing only full ceramic bearings performed within the tolerance for the working life of the clock,” Flanzbaum said. “In addition, this option is the only one that does not require added lubrication, which is a must for a system that is going to run unattended for several decades. We have tested bearings through 350 million cycles with positive results that exceeded our expectations.”

The only way the clock will tell the correct time is with the assistance of visitors to the mountain. They can add energy to the clock’s storage system by winding up a capstan, in which a series of differentials turn three large pinion gears. These gears mesh with the three arms of the rack segments, which in turn connect the power system to the counterweight.

Flanzbaum was amazed at the thought and detail that have gone into the 10,000 Year Clock.

“Participating in a project like this allows us to develop long-term thinking. We are all here for a certain period of time and we have to make it count. What are we going to pass

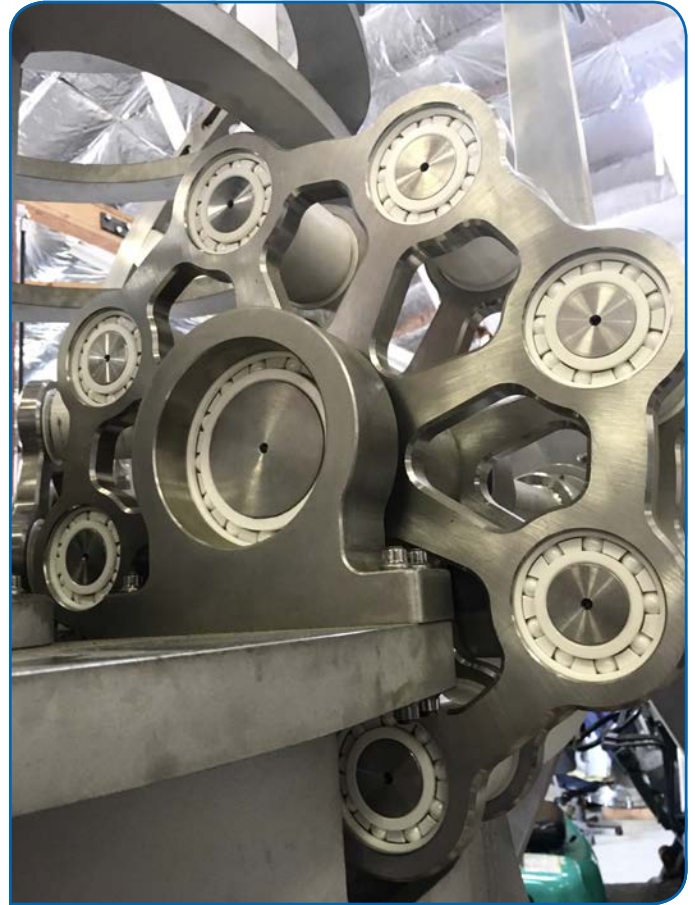

The pinion gear that is part of the energy storage system.

on to future generations? The idea here is to inspire people and try to change the way they think about time; try to make them take advantage of it. Once in a while, we should take a moment to reflect about what we are doing in a long-term basis and ask ourselves, are we going in the right direction?” Flanzbaum said.

Though the completion date is not confirmed, construction has begun inside the mountain in Texas and the clock itself is being machined in California and Seattle. The 10,000 Year Clock might very well be the kind of massive project that helps link the technology of the past with the technology of the future.

“We should always be cognizant of the future to know where we’re headed and how exactly we’re getting there,” Flanzbaum added.

To learn more about the 10,000 Year Clock visit www.longnow.org or read our article about its backstory here: www.geartechology.com/issues/0709x/addendum.pdf. To learn more about Boca Bearings role in the project visit www.youtube.com/watch?v=M7eDpynPNYo. **PTE**



We kick acid.

Having washdown or corrosion issues? It's time to kick acid with our **Food Industry Package**. It conquers corrosion with its epoxy primer, USDA finish, fully encapsulated stator, epoxy conduit box, and stainless steel TorqLOC® keyless hollowshaft. It's no wonder that our motor lasts 10 times longer than the competition in extreme environments such as the poultry industry!

SEW
EURODRIVE

— Driving the World —



Virtually Impenetrable Protection

FAG SuperTac II Seals

Selecting the right seal arrangement to protect against contamination is often the most important consideration when choosing a bearing and housing assembly. Thanks to Schaeffler's FAG SuperTac II Taconite Seals, this crucial decision is now a no-brainer.

Featuring a non-contact seal design that eliminates shaft wear, exceptional high-speed capabilities as well as the ability to accept greater misalignments than lip seals, FAG SuperTac II Taconite Seals from Schaeffler will help keep your machine downtime to a minimum.

Even under conditions like those shown above.

