

# Power Transmission Engineering®

JUNE 2020

## MOTORS

GEARMOTORS  
LINEAR MOTION





**You could always rely on your brother for the best protection.**

**You still can. With Brother Gearmotor's industry-best 5-year limited warranty, you can be assured of the best protection and performance on every standard model.**

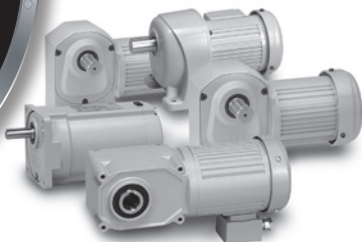

With premium protection comes the ultimate peace of mind. That's why Brother leads the way once again, by shielding its entire line of standard gearmotors with the industry's best warranty. No matter how far the journey or how rough the path, rest assured you've got the protection you need right at your side. Brother...we've got your back.

**Call us today for a sample gearmotor to try out.**

**brother**  
at your side

866.523.6283  
BrotherGearmotors.com

# Power Transmission Engineering®

JUNE 2020

[22]



A Publication of  
The American Gear  
Manufacturers Association

[32]

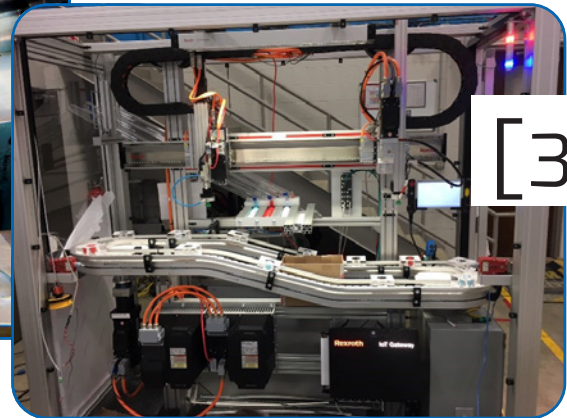

## FEATURE ARTICLES

- [22] **A Little Peace of Mind**  
Condition monitoring technology evolves for gear drives, gearmotors and gearboxes.
- [28] **Upgrading Air-Cooled Heat Exchangers (ACHE) and Cooling Towers**  
Highly efficient, harsh-duty motors are important, but so are a number of additional factors.
- [32] **The Transparency Initiative**  
Bosch Rexroth's smart factory improves production process one application at a time.

## TECHNICAL ARTICLES

- [42] **Dynamic Behavior of Planetary Gears**  
The different behavior of planetary gears with sequential and symmetric gear mesh is explained in this paper.
- [48] **Combining Gear Design with Manufacturing Process**  
How design software can determine if an intended manufacturing process is feasible or not.
- [54] **Transverse Magnet Flux — AKA Hybrid Step Motor Driver Techniques**  
The third in a series of articles covering the development of the motors, drivers, and control methods for transverse flux and step motors.

## Stay Connected



Follow us on Twitter  
[twitter.com/#!/PowerTransMag](https://twitter.com/#!/PowerTransMag)



Connect with us on LinkedIn  
[www.linkedin.com/groups/Power-Transmission-Engineering-PTE-2950055](https://www.linkedin.com/groups/Power-Transmission-Engineering-PTE-2950055)



Subscribe Online  
[www.powertransmission.com/subscribe.htm](https://www.powertransmission.com/subscribe.htm)

Vol. 14, No. 4. POWER TRANSMISSION ENGINEERING (ISSN 2331-2483) is published monthly except in January, May, July and November by The American Gear Manufacturers Association, 1840 Jarvis Ave., Elk Grove Village, IL 60007, (847) 437-6604. Cover price \$7.00. U.S.

Periodicals Postage Paid at Elk Grove Village IL and at additional mailing offices. Send address changes to POWER TRANSMISSION ENGINEERING, 1840 Jarvis Ave., Elk Grove Village, IL 60007.

The American Gear Manufacturers Association makes every effort to ensure that the processes described in POWER TRANSMISSION ENGINEERING conform to sound engineering practice. Neither the authors nor the publisher can be held responsible for injuries sustained while following the procedures described. Postmaster: Send address changes to POWER TRANSMISSION ENGINEERING, 1840 Jarvis Avenue, Elk Grove Village, IL, 60007. ©2020 Contents copyrighted by THE AMERICAN GEAR MANUFACTURERS ASSOCIATION. No part of this publication may be reproduced or transmitted in any form or by any means, electronic or mechanical, including photocopying, recording, or by any information storage and retrieval system, without permission in writing from the publisher. Contents of ads are subject to Publisher's approval.

**KYODO YUSHI**

CONTACT US [INFO@KYODOYUSHIUSA.COM](mailto:INFO@KYODOYUSHIUSA.COM)

Your local contact  
for special grease  
and lubricants

Kyodo Yushi USA Inc.  
1701 Golf Road, Suite 1-1108  
Rolling Meadows, IL 60008  
Phone 847-364-2020  
URL [www.kyodoyushiusa.com](http://www.kyodoyushiusa.com)

**BEYTA GEAR SERVICE**

PUTTING  
A LIFETIME  
OF  
GEAR  
DESIGN  
EXPERIENCE  
TO WORK FOR YOU

- Reverse engineering
- Gearbox upgrades
- Custom gearbox design
- Specification development
- Project management
- Vendor qualification
- Design reviews
- Bid evaluations
- Tooling design
- Customized gear training
- Equipment evaluation
- Custom machine design

**Charles D. Schultz**  
[chuck@beytagear.com](mailto:chuck@beytagear.com)  
[630] 209-1652

[www.beytagear.com](http://www.beytagear.com)

# Power Transmission Engineering

VOL. 14, NO. 4

## [04] PTEExtras

PTE Videos: **MagnaDrive**; **ABB** Tackles Water Crisis; **MIHow2 Series**; see the latest trade show news and keep track of upcoming schedule changes: [www.powertransmission.com/events.htm](http://www.powertransmission.com/events.htm); postings, social media and events

## [06] Publisher's Page

The Long Road to Recovery

## [08] Voices

Precision Manufacturing and the Digitalization of Linear Motion Technology

## [10] Product News

**Gates** high-performance banded V-belt; **Motion Industries/SEW-Eurodrive** MOVIMOT with Integrated Ethernet/IP; **Emerson** portable IIoT tool for digitized pneumatics; **KISSsoft** implements ISO 6336 changes

## [38] Engineering sMART

Products and services marketplace.

## [60] Industry News

News and notes from **Voith**, **NES** and **Regal Beloit**.

## [62] Advertiser Index

Contact information for every advertiser in this issue.

## [63] Subscriptions

Renew your free subscription today.

## [64] Power Play

3D-3x3 Puzzle Cubes with Gears

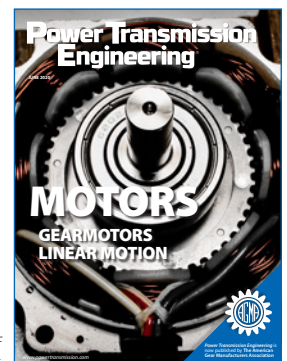

Cover image courtesy of  
QuickSilver Controls



---

# Sustainable technology for more efficient fans

**BALDOR • RELIANCE**

We designed ABB's new Baldor-Reliance® **EC Titanium™** integrated motor drive packages to help meet new system efficiency regulations. These drop-in replacements

- maintain **IE5 efficiency** at part load conditions
- offer increased options for fan design
- are made from readily **available materials**
- run on **standard permanent magnet control drives**

**Efficient. Flexible. Sustainable.**

[baldor.abb.com](http://baldor.abb.com)

**ABB**

**RINGS** | **DISCS**  
4" - 144" OD | UP TO 60"

**EASY  
DOES IT**

**Service. Quality. Speed.**

McInnes Rolled Rings believes in providing superior service and outstanding quality products, ensuring the entire sales process is as easy and as fast as possible for our customers.

When it's seamless, it's McInnes.

**McINNES  
ROLLED RINGS**

1.877-736-4409  
[www.McInnesRolledRings.com/Easy](http://www.McInnesRolledRings.com/Easy)

**PTE Videos**

**MagnaDrive Advantages**

*This video examines the advantages of magnetic couplings and adjustable speed drives:*

[www.powertransmission.com/videos/Energy-Savings-with-MagnaDrive/](http://www.powertransmission.com/videos/Energy-Savings-with-MagnaDrive/)

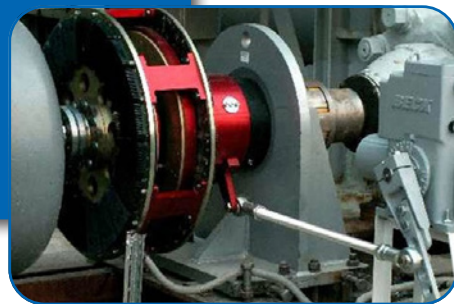

**ABB Tackles Water Crisis**

Bangkok, Thailand is using advanced technology including flowmeters to detect leaks in the piping network and ABB motors and drives to increase efficiency in the city's pumping stations and water treatment centers. Learn more here::

[www.powertransmission.com/videos/ABB-Technology-Helps-Bangkok-Face-Water-Crisis-/](http://www.powertransmission.com/videos/ABB-Technology-Helps-Bangkok-Face-Water-Crisis-/)



**Motion Industries - MiHow2 Series**

Check out this training video from Motion Industries where an electric motor is replaced on a gear unit from SEW-Eurodrive here:

[www.powertransmission.com/videos/MiHow2-Series/](http://www.powertransmission.com/videos/MiHow2-Series/)

**Upcoming Events**

Be sure to check our online event calendar to see the latest trade show news and to keep track of upcoming schedule changes:

[www.powertransmission.com/events.htm](http://www.powertransmission.com/events.htm)





# *Reduce bearing failures with ARMOR BEARING TECHNOLOGY & PROTECTION.*

*RBI Bearing now offers new technologies & protection to reduce bearing failure and extend the bearing life, which means less downtime and reduced repair costs.*

- **ARMOR NANO TECHNOLOGY**
- **ARMOR PERMANENT LUBRICATION**
- **ARMOR COATED PROTECTION BEARING SHIELD**  
*(An Enviropeel Technology)*



**RBI BEARING**  
Bearings + Technology + Solutions

1-800-708-2128 // [www.rbibearing.com](http://www.rbibearing.com)

# The Long Road to Recovery



I've been reading, watching and listening to a lot of pundits lately—economic experts, industry experts, stock market experts, you name it—trying to get some idea of what to expect next.

Heh. My crystal ball is clouded by an upcoming Presidential election unlike any we've ever seen, by a pandemic virus that's changed everyone's way of life and by protesting in the streets on a level not seen in decades.

I've come to the conclusion that anybody who claims to know what the next six months are going to look like probably can't be trusted.

But it's clear that economic recovery is going to take some time. What I'm hearing is that you're going to start seeing some growth. Maybe you're already seeing it as the economies of the world slowly reopen. Unfortunately, so much damage has been done that it will likely be at least another year before sales and production reach previous levels. Depending on the industry, it might be two years or more. We're in for a long haul.

So what are you supposed to do in the meantime?

Well, one thing's for sure. Doing nothing is not the answer. More than ever, your company's focus on technology and education should be at the forefront. Those are the tools that will allow you to get the most out of those employees. By maximizing productivity you'll not only better weather the storm, but you'll have enormous advantages as business picks up.

Ordinarily at this time of year, I'd be encouraging you to participate in upcoming trade shows. Unfortunately, actual live events have been few and far between since the COVID-19 crisis began. IMTS is canceled, along with Hannover Fair USA. The Turbomachinery and Pump Symposium is canceled.

Most of these industry events are offering some kind of remote digital alternative. Classes are still being offered. Technical information is still being shared. For example, the American Gear Manufacturers Association offers a great many educational events throughout the year. Although live, in-person events are on hold because of the coronavirus, their digital offerings can keep you up to date on the technology of gearing. Visit [www.agma.org](http://www.agma.org) for more information.

In addition, I believe very strongly that this magazine can help. Our focus has always been on high-quality technical information. Every issue, we try to bring you the state-of-the-art when it comes to mechanical power transmission equipment.

And this issue is no exception. We have a number of great articles focusing on how the Industrial Internet of Things (IIoT) is transforming all types of factory and production environments. Dr. Ulf Lehmann of Bosch Rexroth describes how Industry 4.0 is transforming the manufacture of linear motion components (p. 8). In "A Little Peace of Mind," Senior Editor Matt Jaster explores how various sensor technologies are being used for condition monitoring of gear drives, gear-motors and more (p. 22). And he follows that up with a close look at Bosch Rexroth's "Factory of the Future" (p. 32).

But it's not all computers and sensors. Experts from Nidec and Motion Industries explain the intricacies of upgrading cooling towers to improve reliability and efficiency (p. 28).

Finally, don't forget our technical articles this issue. We've got "Dynamic Behavior of Planetary Gears," from Renk AG (p. 43); "Combining Gear Design with Manufacturing Process Decisions," from KISSsoft and Gleason; and "Transverse Magnet Flux AKA Hybrid Step Motor Driver Techniques," from Motors expert Don Labriola.

Spend some time investing in yourself, your employees and your company. I promise, some of the articles in this issue apply to you, and there are ideas here that could not only help you get through the economic recovery, but also help your company come out the other end stronger than ever.



# FOR FASTER OVERLOAD PROTECTION



## TORQUE LIMITER

- ✓ Immediate disengagement
- ✓ Compact and backlash free
- ✓ Field adjustable

**THE COUPLING.**

[RW-AMERICA.COM](http://RW-AMERICA.COM)

**R+W**<sup>®</sup>  
A POPPE + POTTHOFF COMPANY

# Precision Manufacturing and the Digitalization of Linear Motion Technology

Dr. Ulf Lehmann, Head of Business Unit Linear Motion Technology, Bosch Rexroth AG

**Digitalization is increasingly transforming mechanical engineering and manufacturing technologies, bringing with it not only unparalleled control and flexibility over production systems but so much more.**

This digitalization is transforming linear motion technology of the future, incorporating sensors and communications technology that provides real-time mechanical performance data.

This data gives engineers new opportunities to integrate the data into their digital workflow. They can implement its application to help manufacturers achieve new levels of precision in the way they machine parts, assemble components and move products through multiple manufacturing stages.

Machine manufacturers are currently experiencing a profound generational

change. Engineers and designers in their mid-30s have grown up with cell phones and the internet. Digital technology plays a very strong role in their private lives and how they view the power of instantly accessible, real-time data to help them live their lives.

This is also increasingly affecting the professional use of technology. The new generation seeks concrete solutions for automation processes and functions rather than components and systems. They assume that all applications, information channels and platforms should be connected and as easy to use as those in private life. This also applies to the selection, dimensioning and configuration of linear motion technology.

Far from being a basic mechanical technology, linear motion technology is poised to transform the modern

manufacturing environment over the next several years. This impact could be in several manufacturing areas, including configuration, ordering and commissioning, operation, diagnostics and maintenance. This is because of all the software tools, online services, intelligent systems and integrated sensors available to support the creation and integration of digitalized linear motion technology.

Digital engineering tools and configurators will intuitively guide system designers more rapidly through all the engineering steps to create linear systems, saving hours or even days of time. The future will see further simplifications in this area, too, including interactive websites with chat facilities. To complete their designs, the users will work directly with the digital twins of the components and systems they configure.

The manufacturers of linear motion technology components and systems face a dual challenge. First, mechanical performance data remains the decisive criterion for the use of components. To achieve the improvements in precision and manufacturing process control envisioned by Industry 4.0, linear motion technology suppliers need to incorporate intelligence into many facets of their systems that, up till now, were purely mechanical or physical.

For example, some manufacturers are supplying each linear module or axis with a digital identity. Digitalized linear motion systems will have module data readily available for commissioning – including all axis data. Users benefit from a plug-and-play commissioning process without having to input data or correct source errors.

The axis parameters can be stored digitally in different products. Whether in a motor encoder, integrated measuring system or digital nameplate, the axis parameters will always be available. The relevant parameters will be





**Dr. Ulf Lehmann** is head of the linear motion technology business unit at Bosch Rexroth. He previously held positions at Heraeus, Carl Zeiss and Eurocopter.



transmitted to the drive system, saving time and minimizing errors during start-up and maintenance. This is just one way digitalized linear motion technology can help contribute to precision manufacturing.

As the use of this technology increases, it will be easier for the machine's key data to be picked up by integrated sensors and passed on to cloud services during operation. In real time, these sensors will constantly supply all operating and environmental data, such as temperature or vibrations. The sensors can be integrated, for example, in screw drives or they can be attached externally to the axes and connected via open interfaces.

An integrated, decentralized intelligence uses algorithms to derive the state of wear from this data, thus enabling condition-monitored maintenance of linear axes. Machine availability, quality, efficiency and other such key information will flow into Overall Equipment Effectiveness (OEE) data to ensure everyone is always well informed – wherever they are – and able to react quickly.

By evaluating sensor data, companies will be able to see future indications of necessary maintenance and service tasks. Enhanced service and maintenance will be a key part of the future of linear motion technology. These advanced services will evaluate the data pulled from machine operation and explain what maintenance, servicing and spare parts are required to prevent unwanted downtime. As

a result, this allows manufacturing equipment and processes to function most efficiently.

Incorporating sensors and other smart technology into the next generation of linear motion systems will better serve the needs and operational expectations of the next generation of automation engineers who use digital technologies in their daily lives. Just as importantly, digitalized linear motion technologies will give machine builders and manufacturing end-users the smart, connected systems they need to enhance the precision manufacturing capabilities of the Industry 4.0 factories.



# eKontrol

## OFFERS ELECTRIFIED POWERTRAIN FOR COMMERCIAL VEHICLES

CAO ZHENG, MANAGING DIRECTOR, eKONTROL GMBH

At present, commercial vehicles have become the key breakthrough direction for global automotive electrification. After years of development and market validation, the centralized powertrain arrangement above suspension has become the main structure, among which three technical routes can be divided: direct drive, deceleration drive and multi-speed drive.

The direct drive is a simple way to realize the electrification in the early stage, which is, replacing the conventional combustion engine with an e-motor, and eliminating the transmission system to directly drive the vehicle. The structure is simple and reliable with high transmission efficiency, which is especially suitable for vehicles with driving demands only under low-speed and moderate speed working conditions. However, because the direct drive structure is not dedicatedly designed for powertrain electrification, it focusses on replacement and therefore has limitations. To guarantee the large torque output of commercial vehicles, the volume and weight of the direct drive e-motor must be dimensioned accordingly, which makes the fulfillment of the requirements of lightweight and high integrity of the whole vehicle quite challenging. Accompany with this, the problem of power surplus occurs.

At the same time, direct drive is limited by the maximum power of the single motor, so the requirements of the heavy-duty truck cannot be met, thereby the possible application fields are greatly restricted. The direct drive route is considered as an interim solution for commercial vehicles powertrain electrification.

In addition to urban low-speed conditions, commercial vehicles are more commonly found in the medium speed suburban road, high-speed road and more complex off-road conditions. To fulfill the requirements of all conditions covering “on-road and off-road” and “medium and heavy-duty,” a superior technology route must apply. To ensure both the power and

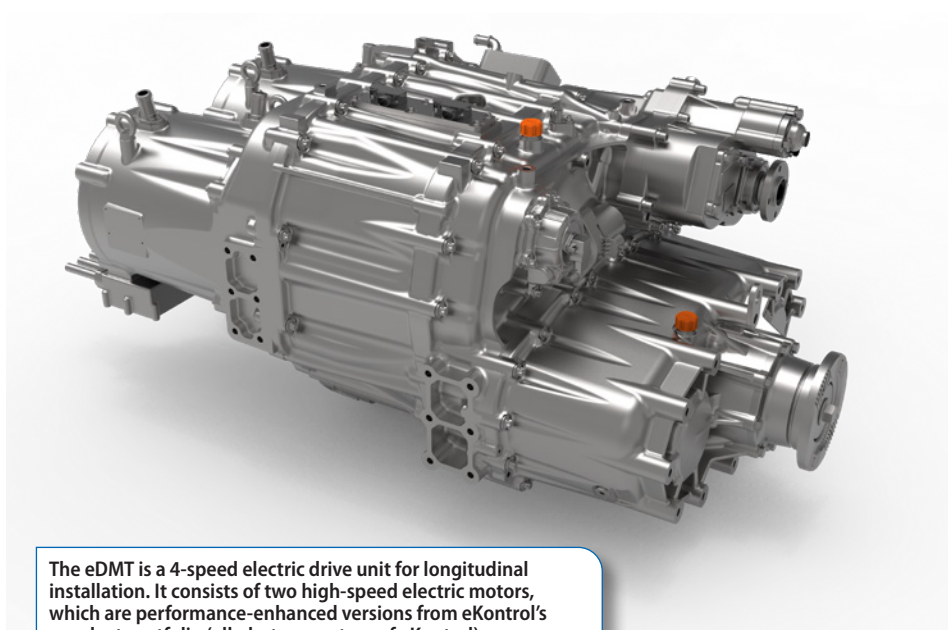

The eDMT is a 4-speed electric drive unit for longitudinal installation. It consists of two high-speed electric motors, which are performance-enhanced versions from eKontrol's product portfolio (all photos courtesy of eKontrol).

maximum speed performance while improving the transmission efficiency, for electrified commercial vehicles, it has become a consensus in the industry that multi-speed powertrain is still essential.

By introducing a multi-speed transmission, the drive system can amplify the output torque. Under the premise of meeting the vehicle's power demands, the size and weight of the e-motor can be reduced, at the same time the higher efficiency and higher power density of the whole system can be achieved, while covering both low-speed torque and high-speed efficiency demands under climbing and high-speed working conditions. Because of the rated current reduction coming from the e-Motor downsizing, the whole powertrain system minimizes the loss and capacity of the battery. The multi-speed drive is especially suitable for medium and heavy-duty trucks on high-speed roads, super-heavy vehicles for off-road conditions as well as non-urban commercial vehicles such as highway coaches and suburban buses. It has a great market prospect and development potential and will bring a revolution for commercial vehicle electrification.

### eDMT – The Electrified Powertrain System Solution

Nowadays the mechanical Automatic, Manual Transmission (AMT) is mainly used in electrified commercial vehicles with “on-road and off-road” and “medium and heavy duty” applications, which is based on the conventional mechanical automatic transmission cooperating with a single motor. Three main shortages are existing in this powertrain configuration. Firstly, the maximum power of a single motor is still limited, which cannot meet the power demand of large heavy-duty trucks. Secondly, the power interruption of mechanical automatic transmission while shifting leads to poor shift comfort and reliability. Thirdly, affected by the heavy load on the ramp, the phenomenon of “unable to shift” often happens, resulting in safety problems.

To realize the continuous power shift, a rather mature solution in the passenger car market is available — automatic transmission (AT), but it has a disadvantage in high cost and low efficiency, which is not suitable for further application in electrified commercial vehicles; on the other hand, the dual-clutch transmission (DCT) can also

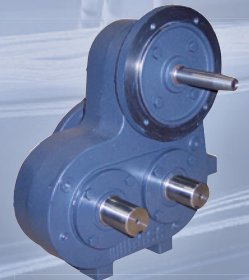
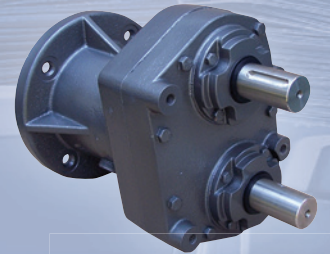

What **if...**

your application  
needs something not  
found in a catalog?

**Accustomed to customs** – one size does not fit all, and sometimes your application requires an engineered-to-order speed reducer and gear drive. Our engineering and technical support teams are proficient in working closely with our customers to design and develop speed reducer and gear drives specific to the application requirements, when what's in the catalog won't work!

For more information, email [hubsales@regalbeloit.com](mailto:hubsales@regalbeloit.com).

[regalbeloit.com/HubCity](http://regalbeloit.com/HubCity)

**Creating a better tomorrow™ ...**

realize, but its key component, dual-clutch is complicated in structure with high-reliability requirements, hence its application in commercial vehicles is restricted.

The company eKontrol, an established manufacturer of electric and hybrid powertrains from Suzhou, China, has creatively developed the eDMT (electric Dual Motor Transmission) to be used in vehicles with a total weight of 31 to 90 tons, after an in-depth analysis of various technical routes of

the drive system and comprehensive investigation of user needs. The eDMT is a 4-speed electric drive unit for longitudinal installation. It consists of two high-speed electric motors, which are performance-enhanced versions of existing tried and tested units from eKontrol's product portfolio. The system's maximum power from the electric motors is 400 kW and it has a maximum

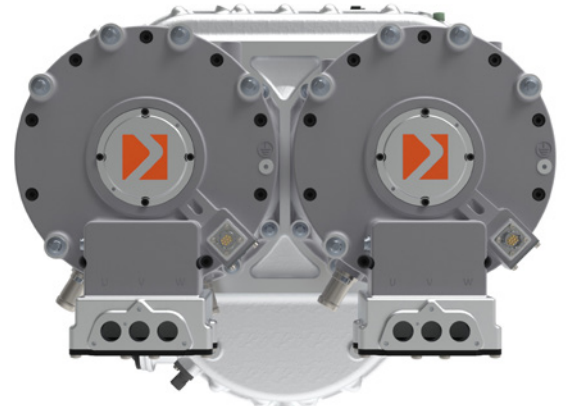

Exterior view of the electric machine drive unit.

combined input torque of 800 Nm.

The system succeeds in dynamic gearshift through high-speed dual motors as a power source, modular transmission combinations, sequential power shift mechanism and precise fixed-point active lubrication system. The combination of various working modes greatly improves the transmission efficiency and power density of the electric drive unit, realizes the lightweight of the total system, and greatly prolongs the service life of the product, thus providing a highly reliable, efficient and maintenance-free powertrain system for commercial vehicles electrification.

### Structure Principle

The eDMT structure principle consists of: Dual-motor (400 Nm, 10,000 rpm): High-speed motors reduce the peak torque. Compared with the single motor with large torque, the volume and cost of the motor are greatly reduced.

Designed with five parallel shafts, 2 motor input shafts, 2 output shafts (1 drive output shaft, 1 PTO shaft), 1 countershaft. The two-way gear lubrication pump and PTO are connected with the EM2 through the fixed shaft gear set.

Three mechanical gear ratios are available. EM1 shifts the module through dog-clutch A, enables the connection with the first gear set or third gear set; EM2 shifts the module through dog-clutch CU and connects to the second gear set or EM1.

There are 2 mechanical dog-clutches with minimized drag loss. The shifting system is activated with an electric



### Your Objective:

One face in perfect alignment with another. *For infinity.*

### No problems. No distress. No delays.

That's the same objective you have for choosing your gear producer. Circle Gear's objective is to engage with every customer's objectives.

- ▶ One to 1000 gears
- ▶ Customer designed or reverse engineered
- ▶ Gearbox repair, rebuild or redesign
- ▶ OEM or end-users
- ▶ ISO 9001:2015 Certified

1501 S. 55th Court, Cicero, IL 60804  
 (800) 637-9335  
 (708) 652-1000 / Fax: (708) 652-1100  
 sales@circlegear.com  
 www.circlegear.com



Spiral and Straight Bevel Gears (*Cut, Ground or Lapped*) • Spur Gears • Helical Gears • Long Shafts • Herringbone Gears • Involute and Straight Sided Splines • Internal Gears • Worm and Worm Gears • Racks • Sprockets • ISO Certified



Partnering with QualityReducer to provide Gearbox repair, rebuilding and reverse-engineering.

## **HYDRAULIC SHAFT CONNECTIONS**



## **MECHANICAL SHAFT CONNECTIONS**

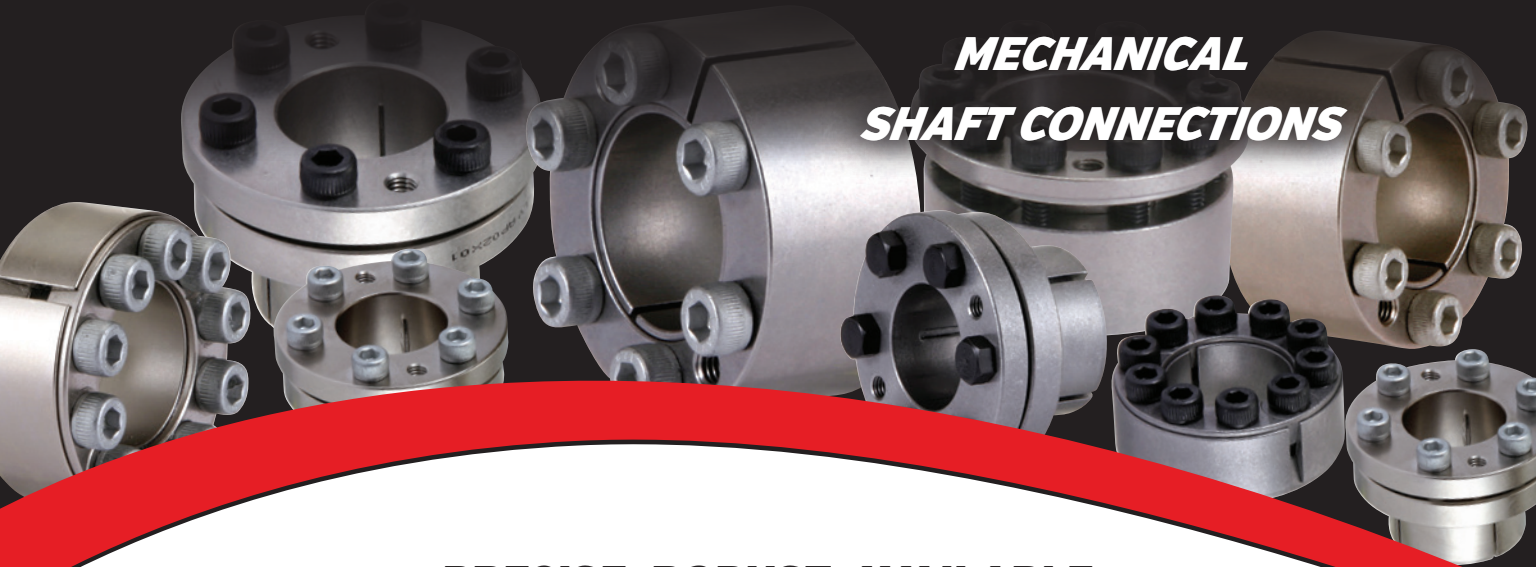

***PRECISE. ROBUST. AVAILABLE.***

### **Keyless Shaft Bushings**

- Precise & Reliable Shaft Component Mounting
- Single-Screw Models for Fast & Frequent Use
- Steel, Nickel-Plated, and Stainless-Steel
- Variety of Mounting Styles Available
- English & Metric Sizes in Stock
- Engineering Assistance / **Fast** Delivery



[www.zero-max.com](http://www.zero-max.com) 800.533.1731

**ZERO-MAX®**

control module. The components consist of one driving motor, one shift drum and two shift forks.

The transmission has a modular design, combination use of gearbox and the transfer case (Module 2) are possible.

### Application & Vehicles

With the platform and modularization as the basic design idea, eDMT can fully cover the commercial vehicle products of “from on-road to off-road” through the arrangement and combination of various motors, gearboxes and transfer cases, mainly including:

12–55 ton road trucks and special purpose vehicles to meet various conditions such as classified highways, environmental sanitation, logistics, and engineering operations;

50–100 tons of super heavy-duty field vehicles, such as mining dump trucks, port tractors and short factory barges;

25–55 tons of urban muck trucks, suitable for the mixed conditions of urban roads and suburban roads to meet the construction needs of urban construction sites;

10–14 m highway coaches and suburban buses to meet the highway passenger transportation, tourism or suburban lines under high-speed conditions;

12–18 m city buses, such as 12–13.7m city bus, 10–13m double-decker bus, 16–18m articulated bus.

The eDMT from eKontrol offers a unique solution for electrifying large commercial vehicles with complex operating conditions covering city and highway travel speeds or steeply inclined roads. With a suitable and efficient driveline, electrification is not only possible but profitable in more areas of the transportation sector beyond passenger cars and city buses.

#### For more information:

eKontrol GmbH  
Zhengcao@auto-ekontrol.com  
www.auto-ekontrol.com

## Gates Corporation

OFFERS HIGH-PERFORMANCE BANDED V-BELT

Gates recently introduced the world’s first wrapped V-Belt technology using Ethylene Elastomer (EE) compounds for original equipment manufacturers (OEMs) in the agriculture, forestry and heavy industrial markets. The launch of the Xtreme V-Force Mega banded V-belt platform leverages Gates’ materials science and manufacturing process expertise to produce unique EE-based solutions that provide customers with increased performance and uptime, and extended operating temperatures.

market, including:

- An extended operating temperature range from –40°C to 130°C;
- A 30% increase in load capacity and durability, which enables:
- Performance in even more demanding applications;
- The ability to design higher-load drives without increasing the design footprint on today’s high-powered equipment
- Improved flex for higher-speed drives;
- The elimination of chlorinated



“At Gates, transforming our industrial belt platforms using Ethylene Elastomer compounds is a priority,” said Tom Pitstick, CMO and senior vice president of product line management for Gates. “With the development of our PowerGrip GT4 synchronous belts, G-Force RedLine CVT power sports belts and the new Xtreme V-Force EE banded belt family, we are leading the way in advanced materials development in our industry.”

The new Gates Xtreme V-Force Mega belt offers a number of benefits vs. currently available products on the

polymers, which improves the overall environmental impact of these products.

Ethylene Elastomers, which involve complex processing technology, help enable a number of the performance advantages of this new belt platform. Gates’ continued focus on the intersection of materials science and process engineering is what has enabled the company to bring these and other Ethylene-based products to market.

#### For more information:

Gates Corporation  
Phone: (303) 744-5800  
www.gates.com/xtreme



# GAM

## INTRODUCES GSL ROBOTIC STRAIN WAVE GEARBOXES

GAM announces the release of the new GSL series of strain wave gearboxes. The new gearboxes provide zero-backlash and high torque in a small gearbox for robotic and motion control applications.

The GSL gearbox uses harmonic gearing for a very compact design that easily integrates into applications requiring high ratios and high precision in a small form factor. The GSL series is available in frame sizes 14 to 40 and reduction ratios 50:1 to 160:1.

“GAM has always been known for our breadth of products,” said Craig Van den Avont, president at GAM, “and with the introduction of the GSL strain wave gearbox, we bring that breadth of product to our zero-backlash gearbox offering including our GCL series cycloidal gearbox and our revolutionary GPL zero-backlash planetary gearbox.”

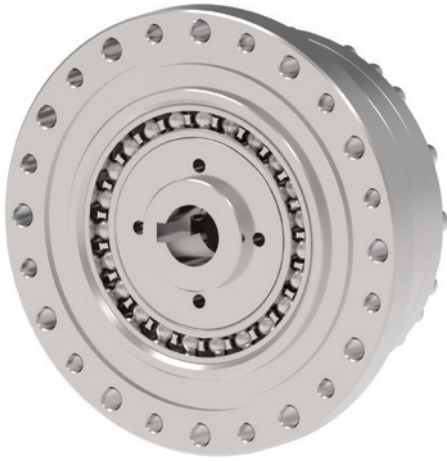

Options for the GSL series include the “hat” and “cup” type with keyed bore, hollow, or shaft inputs. The GSL is also offered in basic component form for fully integrating into applications. The GSL series can be used in a wide variety of applications, such as robot joints, autonomous remote vehicles, antenna positions, or any other applications requiring zero-backlash and high torque in a small gearbox.

### For more information:

GAM  
Phone: (888) 426-7117  
[www.gamweb.com/gsl](http://www.gamweb.com/gsl)

**HY-TECH**  
ENGINEERED SOLUTIONS

## POWER TRANSMISSION GROUP

# Custom Power Transmission Products

From Turnkey Solutions to Custom Gears and Gearboxes



- Straight Bevel & Angular Straight Bevel Gears
- Spiral Bevel & Hypoid Spiral Bevel Gears
- Spur/Helical/Worm Gear Cutting
- Spur Shaping
- Thread Milling
- Racks
- O.D. Grinding
- I.D. Grinding
- Centerless Grinding



[www.powertransmissiongroup.com](http://www.powertransmissiongroup.com)  
[www.ptggears.com](http://www.ptggears.com) / (814) 938-5552

**HY-TECH**  
ENGINEERED SOLUTIONS

# 60 Years Proven

ROBOTICS • AEROSPACE • DEFENSE • TRANSPORTATION • MEDICAL

When machine failure is not an option,  
they call on Spiroid.



**SPIROID**  
HIGH TORQUE GEARING

Spiroid's skew-axis, high torque gears enable world-class power density in a small footprint.

Visit online to learn more. [SpiroidGearing.com](http://SpiroidGearing.com)

# MOLON

MOTOR & COIL CORPORATION



CERTIFIED  
ISO 9001-2015  
ISO 13485

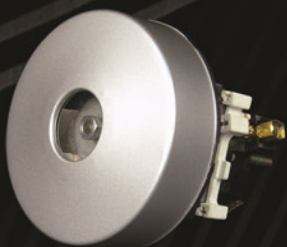

## Motor Solutions Thru American Innovation

We don't leave the manufacturing and engineering of our products to other countries.

**AMERICAN  
MANUFACTURER  
EST. 1954**

VISIT OUR WEBSITE:  
[www.Molon.com](http://www.Molon.com)

## Motion Industries

OFFERS SEW-EURODRIVE MOVIMOT WITH INTEGRATED ETHERNET/IP

MOVIMOT is SEW-Eurodrive's motor-mounted digital frequency inverter for use in decentralized equipment installations. Startup is fast and simple. Integrated Ethernet/IP provides

straight forward and simple access to the upper level PLC, and is completely connector based—no hard-wiring required. Built-in I/O's provide input for photo eye sensors and more, with no additional modules needed. MOVIMOT is available for all designs and mounting positions of our standard gearmotors, with or without a brake.

### For more information:

Motion Industries  
Phone: (800) 526-9328  
[Motionindustries.com/pte](http://Motionindustries.com/pte)

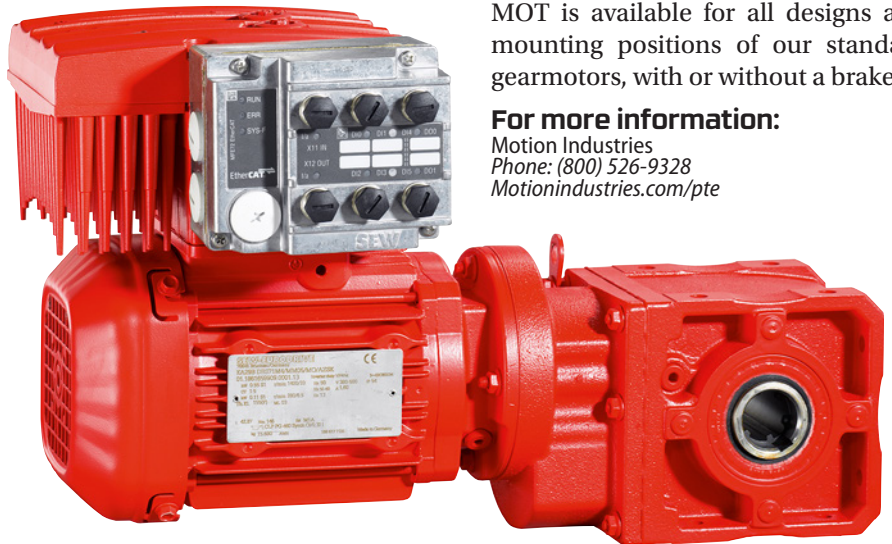

## NES

OFFERS EXPEDIATED BEARING FAILURE ANALYSIS

Failure of rolling element bearings in rotating equipment often results in lost productivity. Bearing failure, without detailed information about the root cause, results in continued loss of valuable production output. Napoleon Engineering Service (NES) is re-allocating its engineering resources to offer fast turnaround on bearing failure analysis to ensure essential businesses

have expedited answers to bearing issues.

According to NES President and Chief Engineer Chris Napoleon, "We want to go the extra mile to keep things running smoothly. We test and fail bearings every day. We're putting that knowledge and our resources to good use to reduce the lead time on typical failure analysis. If someone's production line stops it could be devastating to them and to the general public, even more so now than it usually would be."

Typical failure analysis lead times can be four weeks, but NES will endeavor to get answers in the hands of the customer in 3-5 days on most failures that only require visual or dimensional inspection. "My hope is that no one needs to take advantage of this" says Napoleon. "But we'll be here, picking up the phone in two rings during normal business hours, if our customers need us."

### For more information:

Napoleon Engineering Services (NES)  
Phone: (877) 870-3200  
[www.nesbearing.com](http://www.nesbearing.com)



ISO 9001  
AS9100  
ISO 13485  
ITAR certified  
WBENC

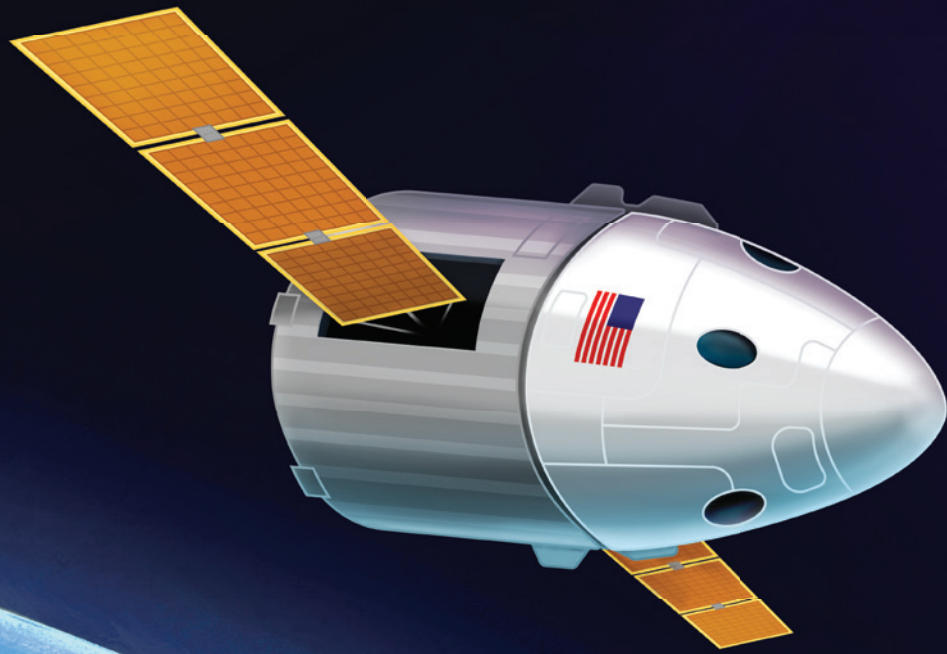

World-class  
Gears for  
...  
Orbitor  
Rover  
Satellite  
Space Station  
Space Plane  
Lander  
Crewed  
Uncrewed  
Launch Vehicle

# For Those Who Know No Limits

Advanced Materials, Engineered to Propel Discovery



# Zero-Max

SERVOCLASS COUPLINGS PROVIDE RELIABILITY AND MISALIGNMENT ADVANTAGES

Zero-Max announced that its Servo-Class Couplings provide important reliability and misalignment advantages in servo motor, and stepper motor driven applications. Demanding applications require a coupling that holds up to shock loads caused by rapid acceleration and deceleration, start/stop conditions, and torque reversals in these servo driven systems. According to Zero-Max testing and field experience, these couplings provide the durability and reliability necessary for longer life and increased machine uptime in these applications compared to other coupling styles.

“Misalignment between shafts on equipment exists in the form of angular, parallel (radial) and axial misalignment,” reports a Zero-Max spokesperson. “No matter how careful two shafts are aligned, they are never ‘perfectly’ aligned. Additional misalignment can also creep in over time from deflection due to torque loads and forces on the machine, machine wear, and eventual settling of the machine base. The ServoClass Coupling, within its ratings,

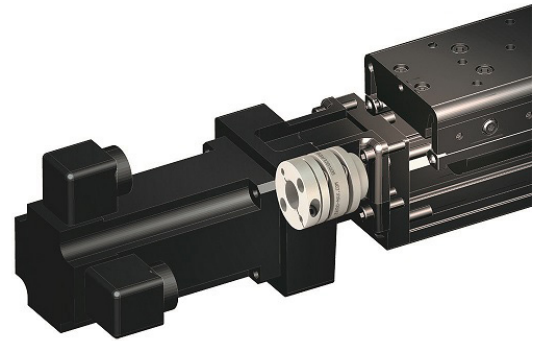

handles these types of misalignments readily and easily.”

“The ServoClass Coupling’s misalignment advantage over bellows couplings will provide for a longer lifetime where the misalignment exists,” reports the Zero-Max spokesperson. “The reason is that, in most cases, the ServoClass Coupling is not as radially stiff as a bellows coupling which reduces the reaction loads on the connected components and stresses within the coupling itself. It is designed to optimally handle torque, rotation,

and misalignment simultaneously, thus providing longer life.”

There are nineteen sizes of standard off-the-shelf couplings. These couplings are ideal for automation applications, printing and packaging equipment, semi-conductor assembly, laboratory automation, medical equipment assembly, and for most products that use ball screws, linear actuators, and servo motors. popular bore sizes.

**For more information:**

Zero-Max  
Phone: (800) 533-1731  
[www.zero-max.com](http://www.zero-max.com)

# Emerson

OFFERS PORTABLE IIOT TOOL FOR DIGITIZED PNEUMATICS



Emerson has introduced a new tool to help pneumatic system users quickly and easily see the potential benefits of integrating IIoT. By connecting the new AVENTICS Smart Pneumatics Analyzer to the compressed air supply on an existing machine, users will have instant analysis options for key machine characteristics such as compressed air consumption and possible leakages.

“By digitizing the pneumatic environment, the Smart Pneumatics Analyzer provides users with the option to directly experience the benefits and potential of IIoT applications on their own machine—in just a few simple steps,” says Dr. Michael Britzger, senior manager, digital transformation for pneumatic technologies at Emerson Automation Solutions. The portable analyzer case contains a

Smart Pneumatics Monitor, AS series air preparation units and a tablet for visualizing the live data. Emerson personnel can show a user within minutes how they can use IIoT-enabled data for insights into their own machine.

The monitor initially detects the system operating state, analyzes data, and provides this processed information to users for status-oriented maintenance, for example. While other solutions collect all available data and transfer it unfiltered, the Smart Pneumatics Monitor evaluates the data locally and uses it to generate information about the status of the system. All data from the valves, as well as from components connected to the I/O modules on the valve system, is read into a microprocessor and processed by means of mathematical algorithms. These algorithms are based on decades of expertise in AVENTICS pneumatic product engineering and application.

Condition monitoring, the collection of operating states and their prediction as the basis for anticipatory maintenance, offers direct advantages for customers using IIoT applications. Because they can anticipate wear before it leads to machine downtimes, they allow users to significantly increase the availability of their equipment and reduce maintenance costs. Once defined limits are reached, the electronics can automatically send messages to ERP and MES systems, as well as maintenance or other staff. Data collected can also help optimize a pneumatic systems' energy efficiency.

"It's important to us to support our customers in their digitization process as equals," adds Britzger. "Based on the analysis results, we therefore also further develop the Smart Pneumatics Analyzer together with our customers especially for their application. This way, users can experience and apply the added value of IIoT for themselves." In addition to being demonstrated by Emerson associates, the analyzer is available for sale to users if they would like to keep the unit at their facility.

#### For more information:

Emerson  
Phone: (888) 889-9170  
[www.aventics.com/us/IIoT](http://www.aventics.com/us/IIoT)

## Parker

### OFFERS COMPONENTS FOR PERSONAL PROTECTIVE EQUIPMENT

During this critical time with the rapidly spreading COVID-19, Parker's Electromechanical and Drives Division North America is proud to be fabricating modular, portable safety equipment and other critical care guards or shields to exact specifications. This personal protection equipment, or PPE, assists hospitals and front-line healthcare providers who are looking

for rapid solutions to help prevent further contamination. Medical staffs are particularly at risk from viruses and other airborne ailments because of their increased exposure while treating infected patients. We want to help these front-line workers stay safe.

This modular PPE includes:

- Ventilator/Defibrillator Carts
- Patient Shield (for intubation)



## INDUSTRY READY

### MOTORS, CONTROLS, AND GEAR REDUCERS

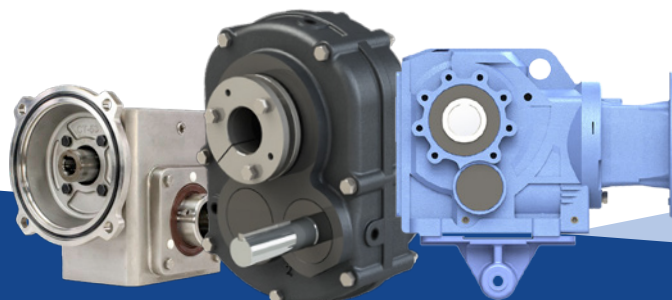

#### Worm Gear Reducers

*Heavy-duty cast iron, lightweight aluminum, and corrosion-resistant stainless steel models available*

#### Shaft Mount Reducers

*Dimensionally equivalent to the popular TXT model, options for conveyor and screw conveyor applications available*

#### Helical and Bevel Reducers

*Inline helical and helical-bevel options available, all models feature cast iron housing and a 2-year warranty*

#### In-Stock Inventory • Fast Shipping • Superior Support

WorldWide Electric offers speed reducer drop-ins for major brands at a fraction of the cost. The diverse product line features a broad range of power and output torque options to support applications including conveyors, material handling and packaging equipment, pumps, fans, and textile machinery.

#### Motors. Controls. Gear Reducers. Value.

1 (800) 808-2131 | [worldwideelectric.net](http://worldwideelectric.net)



- Emergency Room/Aisle Stretcher Protectors
- Modular Hospital Rooms

Complementing the T-slot framing solutions is Parker's T-Slot Aluminum Design Architect, which enables users of any skill level to quickly and easily design products from Parker T-slot aluminum framing components.

The software takes the challenging task of designing products from T-slot aluminum and makes it as simple as building with snap-together blocks. Available as a free download on the Parker website, the software has been lauded by Parker design centers, professional users, and DIYers for its simple, easy-to-use interface, on-the-fly BOM generation, and instant quote capabilities.

Parker Hannifin T-slot Aluminum Design Architect features:

- Free download
- Easy to use
- Standalone tool — No CAD required
- System pre-loaded with Parker components and guidelines
- On-the-fly BOM (bill-of-materials)

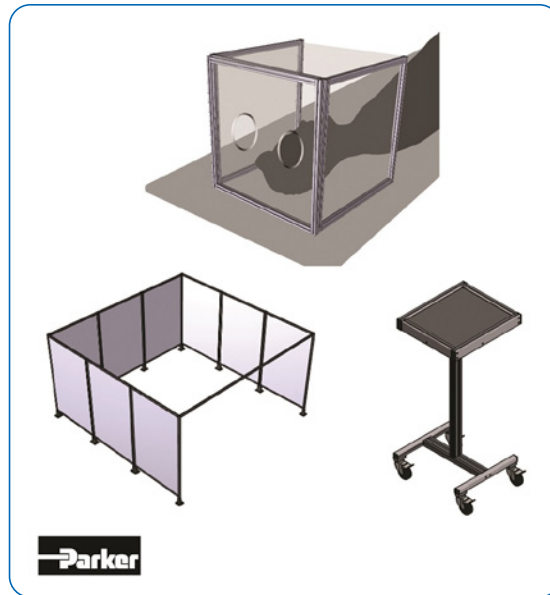

with quick quote capability

- Instantly populates necessary connectors and fasteners
- Native CAD output to Dassault SolidWorks, Autodesk Inventor, and PTC CREO
- Tailored 3D PDF data sheets for every project

**For more information:**

Parker Electromechanical & Drives Division  
 Phone: (704) 588-3246  
[discover.parker.com/LP=18714](http://discover.parker.com/LP=18714)

## KISSsoft

IMPLEMENTS ISO 6336 CHANGES

ISO 6336 is the most important standard for the strength calculation of cylindrical gears. Parts 1 (principles, general influence factors), 2 (flank) and 3 (root) have been revised and republished in 2019. Compared to the previous version, the changes in the



# ISO 6336-1:20

## U.S. Tsubaki

### LAUNCHES PRE-ASSEMBLED TORQUE LIMITER SPROCKETS

U.S. Tsubaki Power Transmission, LLC is pleased to announce the launch of the Torque Limiter Sprocket—a complete assembly providing both the Torque Limiter and sprocket together as one unit. The all-new Torque Limiter Sprocket combines Tsubaki's 100+ years of engineering and manufacturing excellence with high-quality Tsubaki Sprockets and Overload Protection devices to create a single device that provides a powerful and long-lasting torque limiting solution.

Up to now, the method for purchasing torque limiting devices required end-users to assemble the limiting device, springs, bushings and sprocket by themselves. Tsubaki has revolutionized the torque limiting device industry by offering all

these components pre-assembled and bored-to-order in U.S. Tsubaki's Wheeling, IL facility. End-users can now simply install the fully assembled unit to the shaft, set the torque limit, and move forward with operation.

Tsubaki Torque Limiter Sprockets are designed to improve both the customer ordering process and installation experience over the existing line of Tsubaki Torque Limiters. As a solutions provider, Tsubaki continually strives to offer products which will improve customer experience.

**For more information:**

U.S. Tsubaki  
 Phone: (800) 323-7790  
[www.ustsubaki.com](http://www.ustsubaki.com)

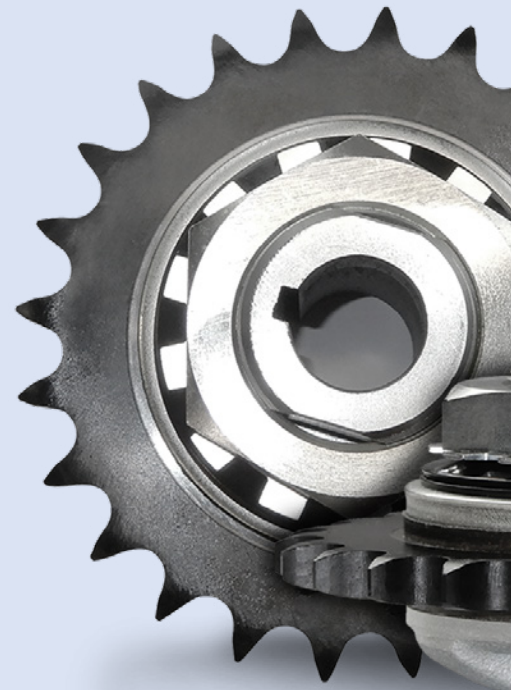

calculated safeties are in some cases significant and will influence the design of gears as well as the minimum safety factors required in future certification guidelines.

The changes, theoretical background and their effects were shown

in a past web demo using examples. In this recording, formulas are compared and the changes in the formulas are illustrated using the *KISSsoft* functions. *KISSsoft* experts will present the effects of the innovations using examples from wind power, EV gearboxes, etc., with different safety factors being considered.

The changes in ISO 6336 are implemented in the *KISSsoft Release 2020 (Module ZA10)*—calculations with version ISO 6336:2006 as well as ISO 6336:2019 can run in parallel.

**For more information:**  
KISSsoft AG (A Gleason Company)  
Phone: (585) 494-2470  
[www.kisssoft.com](http://www.kisssoft.com)

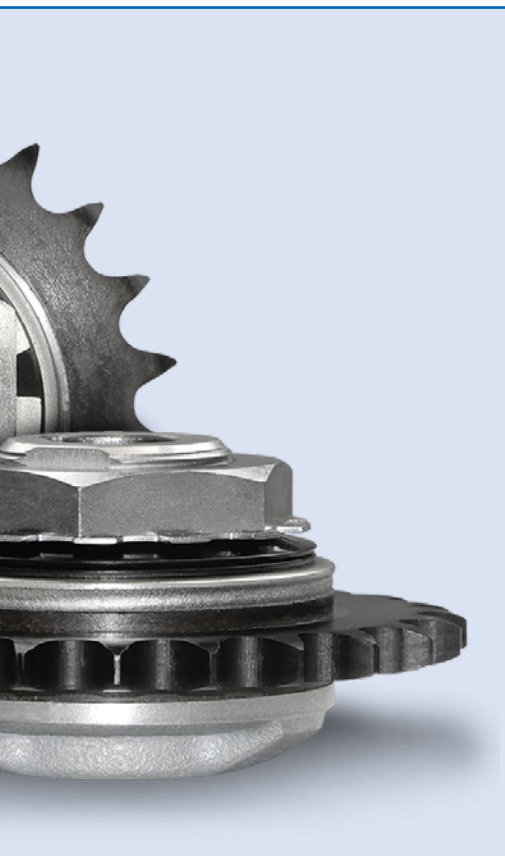

## TWO SPEED SPINDLE DRIVES



Two speed spindle drives, including a large white and orange motor and several smaller orange and silver components.

## PLANETARY REDUCERS

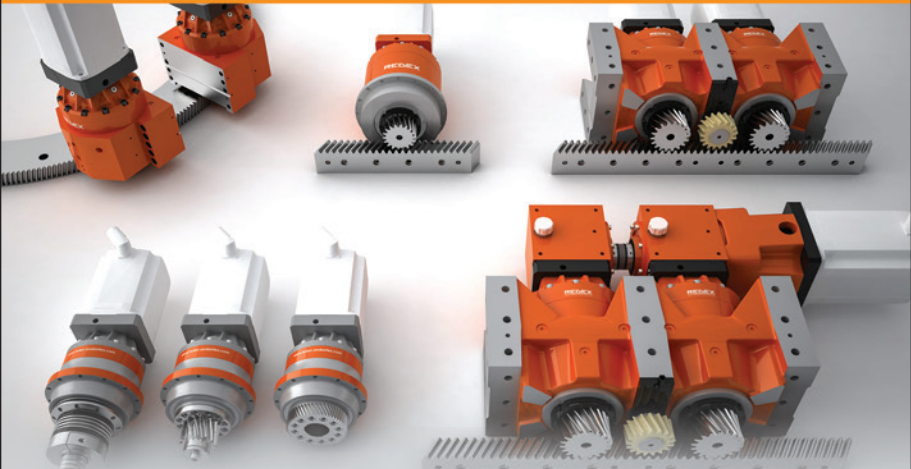

Planetary reducers, including several orange and silver units of various sizes and configurations.

Providing Quality Unique Gearboxes & Solutions  
For Use On Industrial Machinery

# ANDANTEX

 USA Inc.  
andantex.com Phone: 877-966-9151  
info@andantex.com 1705 Valley Road, Wanamassa NJ 07712

# A Little Peace of Mind

## Condition Monitoring Technology Evolves for Gear Drives, Gearmotors and Gearboxes

Matthew Jaster, Senior Editor

Life is full of planned and unplanned activities. Sometimes we embrace those unplanned moments (character-builders some might say), but we also feel a sense of real satisfaction when everything goes according to plan. In the manufacturing world where gear drives and gearmotors are supposed to do exactly as they're told, the unplanned activities could increase costs, cause equipment failures, and stop production altogether. Thankfully, advances in IIoT and smart manufacturing are making it easier every year to eliminate unplanned occurrences on the shop floor.

"Every asset may have a different critical component. In some applications, the gearbox might be the most critical. In other applications, it may be the motor, a bearing, or multiple gearboxes or motors," said Dan Phillips, director, Perceptiv Technologies at Regal Beloit. "Having a scalable system allows for the flexibility to monitor all the components within an asset. In some instances, if a gearbox experiences a failure, the motor or bearings may need to be replaced if the failure is severe and causes damage to these components. Monitoring multiple components provides insight to make the necessary

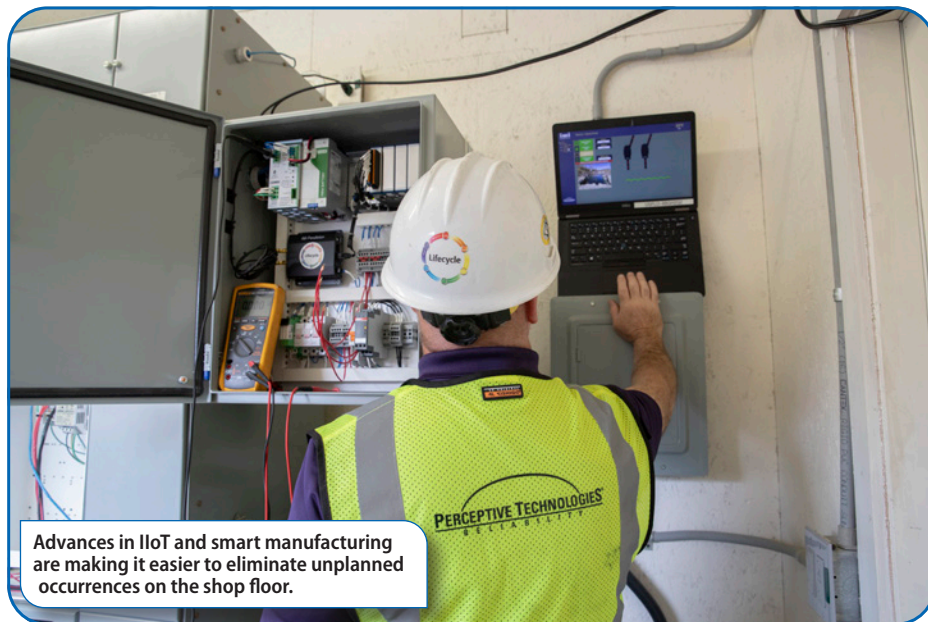

Advances in IIoT and smart manufacturing are making it easier to eliminate unplanned occurrences on the shop floor.

improvements based on data. Additionally, a scalable system allows a user to expand the system to adjacent power transmission applications instead of having to invest in different technology."

The following article examines a few of the condition monitoring systems available in the PT market that help shop personnel stay ahead of unplanned activities regarding gear drives, gearboxes and gearmotors. With an emphasis on smart manufacturing, these tools stay ahead of operation failures, provide real-time data to make better informed maintenance decisions, reduce service and material costs and provide longer service life not just for individual components but entire mechanical systems.

### Regal Offers Wireless Condition Monitoring Solution

The Perceptiv wireless monitoring system is an evolution for Regal's diagnostics and services team. It was launched based on feedback from customers who needed an easy-to-use, expandable wireless vibration and temperature monitoring system for their gearboxes, bearings and motors.

Unlike other wireless systems that provide only "basic" diagnostic data, the Perceptiv monitoring system delivers full waveform and spectral data to provide better predictive capabilities.

This data is multi-functional — vibration and temperature analysis, for example. It is adaptable to any industry or equipment and scalable (25 nodes per gateway). Operator safety is vital as it eliminates the need to be near the equipment. It's

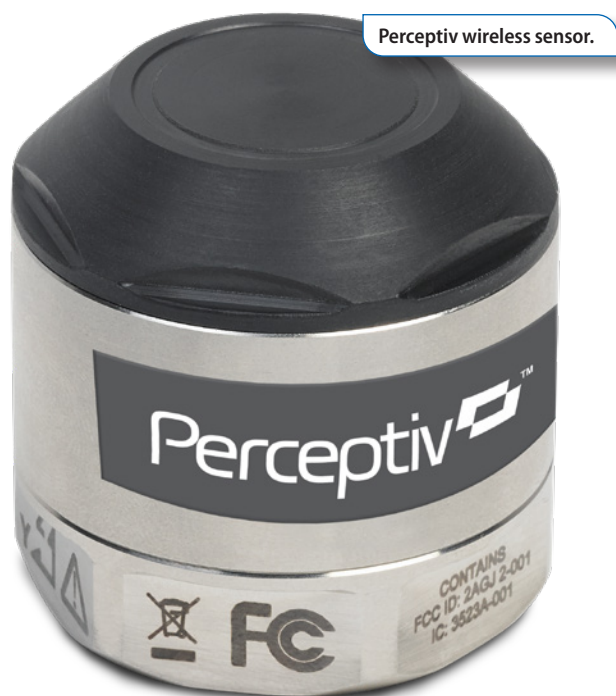

Perceptiv wireless sensor.





**90** MISSILES

**330** SAILORS

**1,100** MILES OUT  
TO SEA

**ZERO  
ROOM  
FOR GEAR  
DRIVE  
FAILURE.**



Whether it's the frontline combat fleet of the U.S. Navy or your own gear drive operation needs, Philadelphia Gear delivers mission-critical performance and reliable, responsive support.

With unmatched expertise that's on call 24/7, plus complete warranty coverage on workmanship and material for any gear drive we service, including those from other manufacturers, we've set the standard in dependability — on land and at sea — for more than 125 years.

**Keep your mission moving.**

Visit [PhilaGear.com/MyMission](https://www.philagear.com/MyMission) to learn more.

also cost-effective, providing a simple installation that allows the operator to monitor many different assets. In addition, the data visualization is web-based, the platform can be located on-site or in the cloud, and the battery offers a two-year lifespan.

“Regal’s technology continues to evolve with our customers. We offer a variety of technologies to align with the needs of our customers’ changing businesses and infrastructures,” Phillips said. “Not too long ago, wired systems were the norm. With the advent of 5G and improvements to communication equipment, we see more and more wireless capabilities driving data to a secure cloud, which allows monitoring from the comfort of your home while being able to keep an eye on your equipment or a plant’s operations.”

Phillips said that Regal can monitor vibration, strain, temperature, power and current voltage. “This toolset allows us to obtain torque, speed, efficiency and reliability data, which ties back to tons, bottles and cartons per hour for our customers. To help make this easier for customers, we use augmented reality. It allows users to look at equipment on a tablet or smartphone to monitor equipment conditions. With just the scroll of a finger, they can peel back equipment layers to look at critical components, read bills of materials, and gain a better understanding,” he added.



Regal MP-56 with vibration sensor.

While product reliability and uptime are the leading justification, Regal sees its customers expanding the scope of this equipment to optimize the performance of their assets or better understand operation and maintenance.

“These additional uses are a result of the lower costs of monitoring systems. In the past, the cost of installation was a significant hurdle, which prevented users from investing,” Phillips said. “Improvements to technologies and communications make it affordable to collect data and deliver it to a cloud-based system, respectively.”

### Rexnord Expands Series 1000 Smart Condition Monitoring System

Proven maintenance savings alone enable manufacturers to recoup their investment in the Rexnord Series 1000 Smart Condition Monitoring System, powered by DiRXN, in less

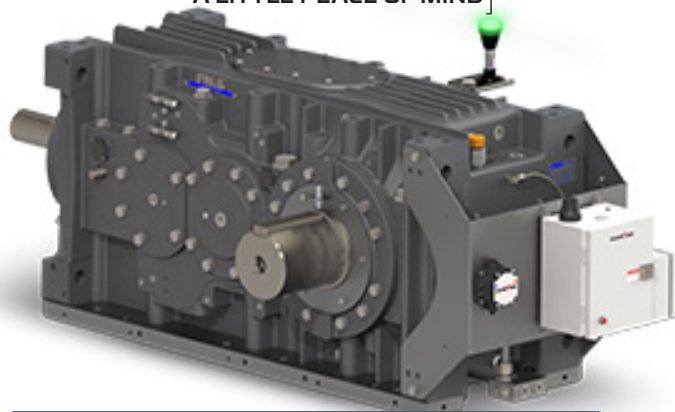

Easy-to-deploy solutions like the Rexnord Series 1000 Smart Condition Monitoring System make maintenance accessible on a sliding scale to match manufacturers’ priorities and budgets.

than a year. Additional productivity gains are driven by increased uptime and enhanced safety.

Customers can now choose from four levels of monitoring, from continuous monitoring of overall gear drive vibration and temperature, all the way up to comprehensive cloud-based notification of abnormalities. And in an industry first, the base model now comes standard on select new Falk V-Class and A-Plus Gear Drives.

These easy-to-deploy solutions make condition-based maintenance accessible on a sliding scale to match manufacturers’ priorities and budgets. Customers get the right information at the right time to further extend their Rexnord products’ already-premium operating life.

“This more cohesive, cost-effective approach eliminates unnecessary maintenance activities and significantly lowers total cost of ownership for mission-critical and standard gearbox assets,” said Rick Morse, Rexnord vice president of innovation and digital solutions. “The new models accelerate the customer’s journey from run-to-failure or schedule-based maintenance to condition-based maintenance.”

The Smart Condition Monitoring System uses proprietary algorithms to continuously compare sensor data against models of healthy gear drive operating conditions. Abnormal conditions trigger alerts to onsite visual indicators, the control system, and at the highest level, the Rexnord Connect Portal.

The system puts data in context, enabling customers to focus on outcomes; teams know what action to take when and why. Manufacturers gain the ability to replace time-consuming, hands-on equipment inspections with digital technology that enhances team safety, extends asset life, and lowers inventory and operating costs.

Morse says the scalable solution addresses current and future customer needs, with hardware and instrumentation incorporating common user interfaces and industry-standard communications protocols.

“We heard from manufacturers in mining, steel, cement, and pulp & paper that they’re keen to deploy condition-based maintenance solutions that can scale for different monitoring applications,” Morse said. “The new series lets you zero in on the most immediate need, with field upgrades whenever you’re ready to move from our base model to one of our more advanced solutions.”

## NORD Offers Intelligent Monitoring and Predictive Maintenance for Gear Units

For condition monitoring, drive and status data are recorded periodically or continuously in order to optimize the operational safety and efficiency of machines and plants. NORD believes this technology continues to provide vital information for predictive maintenance. The objective is to maintain machines and plants proactively, reduce downtimes, and increase the efficiency of the entire plant. IIoT focuses on Internet usage in industrial processes and procedures while the sensors play a role in providing the basis for condition monitoring and predictive maintenance.

This drive-based approach includes the sensorless determination of the optimal oil change time based on virtual oil temperature, pre-processing of drive data in the integrated PLC, and the ability to offer the data to the customer via common interfaces. Gear unit parameters and specific operational parameters make it possible to calculate the oil change time. The NORD solution looks at the oil temperature as a key factor for oil aging in gear units. A hardware temperature sensor is not needed because virtual sensors calculate the current oil temperature continuously by way of drive-specific parameters. The existing VFD from NORD is used as an evaluation unit and the algorithm runs in the internal PLC.

In addition to condition monitoring for gear units, NORD offers TorqueProtect, a gearbox torque monitoring system designed for wastewater treatment facilities, power

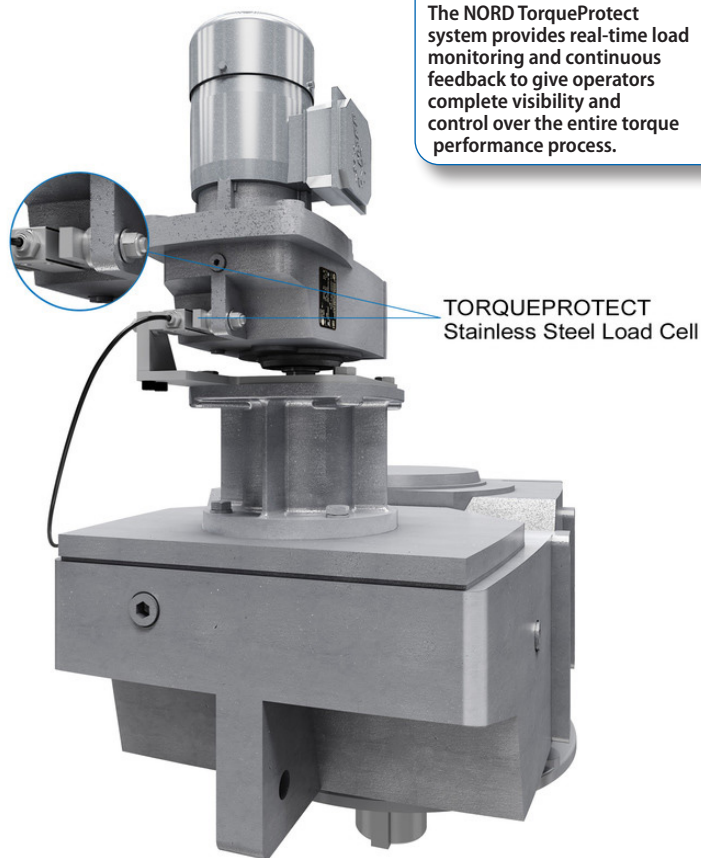

screw jack lifting systems



Did you mean: *DieQua Corporation?*

## The search is over!

For quality screw jacks that give you all the options in a complete package with the most advanced designs, look no further than DieQua.

- 8 ZE sizes with lifting capacities up to 20 tons
- 3 sizes servo compatible
- Precision machine and ball screws
- Standing and rotating versions
- Multiple spindle end connections and driving nut designs

To finally find what you're looking for, check us out on the web, or give us a call.



**ZIMM** USA  
by **DIEQUA**

[screwjacks.com](http://screwjacks.com)  
800-804-8619

generation plants and other industries that require extreme low-speed, high-torque drives.

The NORD TorqueProtect system provides real-time load monitoring and continuous feedback to give operators complete visibility and control over the entire torque performance process. Unlike traditional spring load monitoring systems that can only provide readings at specified maximum load ratings, TorqueProtect delivers continuous feedback, which allows users to know when loads are trending higher or lower than expected and take corrective action as needed.

Torque monitoring is especially critical for wastewater clarifier applications where even small strains in the load cell can create big problems. A clarifier is designed for continuous operation and if the system becomes overloaded for any reason, a million-dollar clarifier may be shut down for several days or weeks. There's also the risk of incurring significant costs associated with repairing or replacing expensive industrial gearboxes that may become damaged without accurate torque monitoring.

### DB Santasalo Looks at Digitalization Opportunities for Condition Monitoring

In 2018, David Brown Santasalo introduced a monitoring system that examines industrial gears. This remote monitoring service is called GearWatch and is available in three packages including:

DBS GearWatch Standard which examines gear unit wear



David Brown Santasalo welcomed 50+ customers and DBS team members to a GearWatch User Day in Jyväskylä, Finland in November 2019.

process through oil particle counting and provides a compact and cost-efficient condition monitoring solution where measurement results are simple to analyze

DBS GearWatch Oil Monitoring is an oil analyzing unit that detects early stages of the wear process and provides a proactive approach to operation with oil quality measurements.

DBS GearWatch Pro is a tailored, monitoring systems for gear units and drivetrains with selected parameters including oil particle counter, vibration, rotational speed, temperature, oil quality, oil pressure and load.

GearWatch can be tailored to specific operating parameters. All the data is monitored by gearbox experts at DB Santasalo's central control center. Not only does it measure

# MASTA IO

NEXT GENERATION CAE SOFTWARE FOR THE DESIGN, ANALYSIS AND OPTIMISATION OF TRANSMISSION SYSTEMS



DESIGN



ANALYSE



OPTIMISE

- Advanced gear, bearing and other component analyses in the context of full system models
- Include bearings from a comprehensive catalogue of over 66,000 bearings from major bearing suppliers covering all major types

Discover more at [www.smartmt.com/masta-bearings](http://www.smartmt.com/masta-bearings)

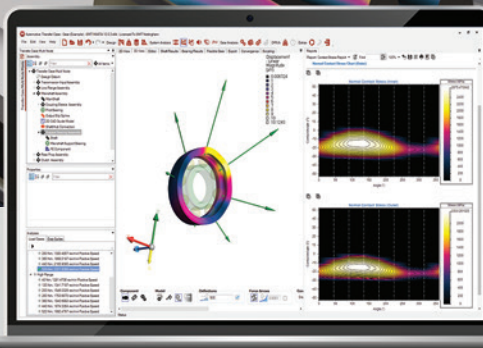

Globally integrated leader in mechanical transmission engineering services and software development  
© 2020 Smart Manufacturing Technology



changes within the gearbox, it can also monitor a full range of equipment including motors, hydraulic systems, and bearings, as required. Furthermore, GearWatch can support any industrial application in process critical industries globally.

David Brown Santasalo welcomed 50+ customers and DBS team members to a GearWatch User Day in Jyväskylä, Finland in November 2019. This provided a forum to share views and experiences of preventive condition monitoring systems, and the opportunities digitalization will bring to condition monitoring now and in the future.

DB Santasalo also showcased the latest GearWatch features and functions, including its ability to detect defects at an early stage through oil particle counting. Customers provided feedback on how the condition monitoring system has improved maintenance actions and minimized product downtime and costly shutdowns.

### The New Enemy — The Empty Shop Floor

For years, this magazine has examined how sensors and mechanical systems have provided real-time data solutions via condition monitoring. This was originally a technology that provided extra safety measures when it came to hazardous applications or training solutions for staffs that lacked the skilled workforce necessary to prevent plant shutdowns.

In 2020, we add pandemic to the growing list of manufacturing challenges. The ability to monitor a gearbox, gear-motor or complete mechanical system from a smartphone in your living room is a nice capability to have when no one

answers the phone and the manufacturing floor is relatively empty.

Thankfully, engineers, technophiles and futurists continue to gaze into the crystal ball and provide new solutions to age-old problems — and for that we're all eternally grateful. **PTE**

#### For more information:

David Brown Santasalo  
Phone: (864) 627-1700  
[Dbsantasalo.com](http://Dbsantasalo.com)

NORD Gear Corporation  
Phone: (888) 314-6673  
[www.nord.com](http://www.nord.com)

Regal Beloit Corporation  
Phone: (630) 364-8800  
[www.regalbeloit.com/brands/perceptiv](http://www.regalbeloit.com/brands/perceptiv)

Rexnord Corporation  
Phone: (414) 843-3000  
[www.rexnord.com](http://www.rexnord.com)



**BEARINGS**  
**LINEAR MOTION PRODUCTS**  
**Bearing MONITORING & MAINTENANCE TOOLS**

**ONE LOGICAL LOCATION** [www.qbcbearings.com](http://www.qbcbearings.com)

Our products are high quality, efficient, competitively priced and are sourced from the most recognized names in the bearing industry.

For more information and to speak to a product specialist, call **1-888-276-4787**

**Quality Bearings & Components**  
 250 Duffy Ave.  
 Hicksville, NY 11801



# Upgrading Air-Cooled Heat Exchangers (ACHE) and Cooling Towers

Tim Albers and John Frese, Nidec Corp., and Glenn Martin, Motion Industries

Many industrial facilities with air-cooled heat exchangers (ACHE) and cooling towers often have older units installed. Depending on the age, repairs, and maintenance done over the years it may have had an impact on performance. Upon conducting site inspections of the equipment, it is sometimes found that ACHE or cooling tower components have degraded. This can result in a system that is not very energy-efficient and delivers sub-standard cooling performance.

API 661 is an American Petroleum Institute (API) standard that details the requirements for air-cooled heat exchangers. API 661 ACHEs are also known as fin-fan heat exchangers, because the hot process fluid flows through finned tube bundles that are cooled by a fan that either pulls or blows ambient air over the tubes. The fan is driven by an electric motor.

Some of the recommendations to reduce energy usage include installing newer high efficiency motors that meet the latest U.S. Department of Energy's regulations, and adjustable speed drives (ASDs) that will adjust the speed of the motor to match the process flow and increase system efficiency.

Many ACHEs are used in the petrochemical industry and are specified to the API 661 specification, since it is considered a critical application. Often, the installation is in a harsh environment, such as close proximity to the ocean or presence of significant sand, dirt, and dust. Due to these considerations, the specification for motor robustness is very high and includes features to enhance the motor's ability for high reliability. Standard totally enclosed fan cooled (TEFC) motors used in API 661 ACHE locations often have incremental features to the industry-standard IEEE 841 motor that was developed for the petroleum and chemical industry.

API 661 calls out several standard drive arrangements, where the motor can be connected 1) directly to the fan, 2) to a right-angle gear attached to the fan, or 3) via a belt drive attached to the fan. When the fan is either belt driven or directly connected to the motor, the motor is installed in a vertical orientation. When the motor is installed shaft up, API 661 states that the belt sheave design should shield the motor from water; however, it also allows using an external

shaft seal to prevent ingress of water into the motor housing. Labyrinth-type seals are typically utilized versus an external V-ring shaft slinger, since these types of seals provide a higher degree of ingress protection (IP 56 to IP 66).

A drive end cylindrical roller bearing is generally required when a motor is used in a belted ACHE application. In direct connected ACHE & cooling tower applications, the motor must utilize Conrad type ball bearings, since cylindrical roller bearings have a minimal radial loading requirement.

Like ACHE motors, cooling tower duty motors also operate in harsh conditions with high humidity, which necessitates utilizing a cast iron frame, bracket and conduit box with seals for IP55 protection. Cooling towers are used at industrial and petrochemical facilities to remove heat from recirculating



Site inspections typically reveal that ACHE equipment or cooling tower components have degraded.

water systems. Even though there are several different types, most have a fan driven by an electric motor that draws ambient air up and out of the top of the cooling unit. Enclosures for cooling tower duty motors are most commonly Totally Enclosed Fan Cooled (TEFC) or Totally Enclosed Air Over (TEAO). Mounting can be horizontal or vertical in a shaft-up or shaft-down orientation. Cooling tower duty motors are available in single speed, variable speed using an adjustable speed drive (ASD), or multi-speed (2 speed, 1 winding or 2 speed, 2 winding) for operation at two designated speeds.

The following table compares the motor requirements of cooling tower duty motors, IEEE 841 motors (up to 444 frame) and 661 branded motors. The table should help in

understanding the different motor product features to aid in selecting the appropriate motor for your cooling units.

Adjustable speed drives are commonly used for the fans on the ACHE and cooling tower units to control air flow and to provide energy savings by better matching motor power consumption to maintain the process temperature requirement. Most premium efficient motors are suitable for use with ASDs, but there are special installation considerations. Facility layout and site conditions might require situations where there could be long motor lead lengths from the ASD to the motor. ASDs use a switching technology called pulse width modulation (PWM) to generate the variable voltage and frequency to the motor. This high-frequency PWM waveform can result in unwanted effects like standing wave

and excessive common mode voltage, which can cause damage to motors and electrical systems. Operation issues can be avoided by proper installation of the drives and support components.

It is strongly recommended to apply motors with an inverter duty winding designed to withstand voltage spikes, per NEMA MG1 Part 31 4.4.2. Bearing fluting protection, such as a drive end ground ring (if installed in an unclassified area) and an opposite drive end bearing if 400 frame and larger, should be considered.

In ACHE applications where the fan is belt driven, changing the belting system from a multiple strand V-belt to synchronous poly chain belting can provide higher efficiency, increase bearing life due to lower belt pull, eliminate

Feature	Summary List of Typical Features on a Cooling Tower Duty Motor	Summary List of Electric Motors Requirements Detailed in API 661 Std.	Summary List of Main Electric Motors Requirement Detailed in IEEE 841 Std. (Up to 444 Frame)	Summary List of Main Electric Motors Standard Features for 661 Branded Motors
Enclosure	Totally enclosed fan cooled (TEFC) or Totally enclosed air over (TEAO) suitable for harsh, high humidity and environment	Totally enclosed fan cooled (TEFC) suitable for petrochemical service	Severe-duty totally enclosed fan cooled (TEFC) suitable for petroleum and chemical service	Severe-duty totally enclosed fan cooled (TEFC) suitable for petroleum and chemical service
Service Conditions	Ambient temperature between -25°C to +40°C and maximum altitude of 1000 m	Rated for operation at 40°C (104°F) ambient temperature at altitudes less than 1000 m (3280 ft)	Ambient temperature between -25°C to +40°C and maximum altitude of 1000 m	Ambient temperature between -25°C to +40°C and maximum altitude of 1000 m
Temperature Rise	Winding temperature rise of 80°C	Maximum winding temperature rise of 80°C	Maximum winding temperature rise of 80°C	Maximum winding temperature rise of 80°C
Construction	Corrosion resistant cast iron motor frames and end brackets	Cast steel or corrosion resistant cast iron motor frames	Cast iron construction, including the frame, end brackets, fan cover. Corrosion-resistance, includes stainless steel nameplate, paint on external surfaces and on exposed internal surfaces.	Cast iron construction, including the frame, end brackets, fan cover. Corrosion-resistance, includes stainless steel nameplate, paint on external surfaces and on exposed internal surfaces.
Seals/Ingress	Ingress protection of IP 55 minimum.	Suitable shaft seals and bearing lubrication system when motor is installed vertically	Ingress protection of IP 55 minimum. Non-contacting labyrinth type shaft seals are commonly used to achieve IP 55 or higher.	Ingress protection of IP 55 minimum. Non-contacting labyrinth type shaft seals are commonly used to achieve IP 55 or higher.
Drains	Replaceable, corrosion-resistant drains at the lowest point of enclosure	Drains installed at the lowest point of the frame and/or endshield	Replaceable, corrosion-resistant drains at the lowest point of enclosure	Replaceable, corrosion-resistant drains at the lowest point of enclosure
Starting	Full voltage starting	Full voltage starting	Full voltage starting*	Full voltage starting*
Bearing Life		Grease lubricated bearings with at least 40,000 hours L 10 bearing life	Regreaseable bearings with at least 50,000 hours L 10 bearing life when direct connected	Regreaseable bearings with at least 50,000 hours L 10 bearing life when direct connected
Foot Flatness			Special mounting foot flatness for ease of installation and proper alignment	Special mounting foot flatness for ease of installation and proper alignment
Shaft Runout			Special shaft runouts – 0.001" for shafts up to 1.625" and 0.0015" for larger shafts	Special shaft runouts -0.001" for shafts up to 1.625" and 0.0015" for larger shafts
Vibration			Unfiltered vibration not exceeding 0.08 in/s for 4-pole motors	Unfiltered vibration not exceeding 0.08 in/s for 4-pole motors
Noise			Low noise level not exceeding 90 dBA sound power	Low noise level not exceeding 90 dBA sound power
Division 2			Suitability for installation in a Class I Division 2 or Class I Zone 2 area	Suitability for installation in a Class I Division 2 or Class I Zone 2 area
Belting bearings				Drive end roller bearing for belted applications
Incremental Sealing	RTV sealant on the bracket register fits and bolt holes for incremental sealing			RTV sealant on the bracket register fits and bolt holes for incremental sealing
Shaft up/down draining	Shaft up and shaft down mounting arrangements for proper draining			Shaft up and shaft down mounting arrangements for proper draining
Drip Cover	Optional Drip cover kits available when motor is installed shaft down			Optional Drip cover kits available when motor is installed shaft down

\* Most, if not all, off the shelf 841/661 branded motors come standard with an inverter duty winding suitable for 20:1 variable

Sources for table:

API Std 661 (R2018) Petroleum, Petrochemical, and Natural Gas Industries - Air-cooled Heat Exchangers, Seventh Edition

IEEE 841-2009 IEEE Standard for Petroleum and Chemical Industry—Premium-Efficiency, Severe-Duty, Totally Enclosed Fan-Cooled (TEFC) Squirrel Cage Induction Motors—Up to and Including 370 kW (500 hp)

tensioning which reduces maintenance cost, and reduce the number of sheaves, thereby reducing component count and providing increased safety. Synchronous belting is now available with higher temperature range (up to 248°F) and options to overcome static conductivity.

Additionally, there are new developments in fan and drivetrain components used in the design of these cooling units that can improve the units' cooling performance and energy efficiency. Items such as FRP (Fiberglass Reinforced Plastic) fan blades can provide greatly improved performance over the aluminum fan blades that typically come with the ACHE units. FRP fan blades are available for ACHE units and cooling towers. Various materials and designs are available. All have improved performance over aluminum fan blades. One design offered can improve fan efficiency up to 20% and air flow up to 10% over the manufacturer's standard FRP fan blade. There are other optional features such as an inlet bell on the ACHE fan blades to reduce noise and gain up to 5% efficiency.

In one case, it was found that the ACHE equipment—although not very old—and designed per API 661 as a guideline, could not achieve the required performance. The company was looking at doing an expansion at another site, in order to meet the product demand because they could not achieve the needed output due to process cooling limitations. It was discovered that the aluminum fan blades on the cooling units they had purchased could not handle the air flow demand. This was overcome by replacing the fan blades with FRP fan blades, which could handle the required demand.

Here are some additional items that should be evaluated and considered for upgrade:

Composite tube couplings that are available for cooling towers which are almost  $\frac{1}{2}$  the weight of a steel coupling. This can greatly improve bearing life on the motors and gearboxes, as well as provide resistance to corrosion. They also have a lower coefficient of thermal expansion, which reduces concern for axial thrust.

Newer cooling tower gearboxes that have improved shaft seals using V rings and isolator seals. They are better at keeping water out of the oil by providing an expansion chamber in place of a breather. There are manufacturers offering factory trade-out programs with a warranty and shorter lead times.

There are newer bearing designs, used in the drivetrain for the cooling unit that provide greater moisture and corrosion resistance, as well as greater bearing life and higher tolerance to misalignment.

Adding a cooling tower brake can provide features such as slow-stopping a fan, which is a great timesaver for maintenance personnel. The brake can also hold the fan in place to avoid wind milling, which can cause damage in high wind as well as provide lockout for maintenance safety. There are

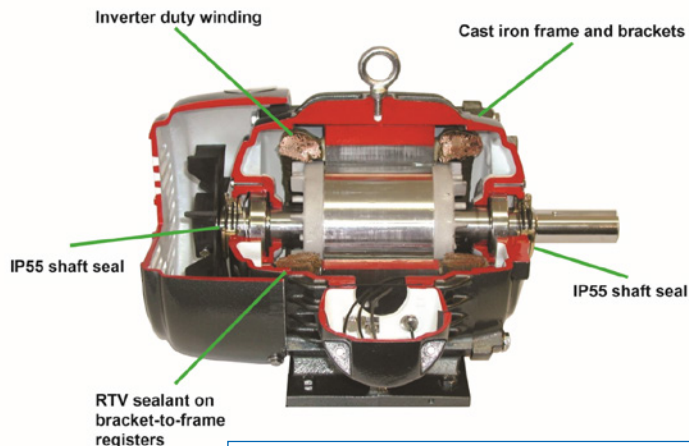

Like ACHE motors, cooling tower duty motors also operate in harsh conditions with high humidity, which necessitates utilizing a cast iron frame, bracket and conduit box with seals for IP55 protection. Image courtesy Nidec Corp.

even less intrusive devices that can be added—such as a torque arm—which helps eliminate wind milling.

All of these improvements can extend unit life and reduce downtime for cooling units. Having the units inspected and evaluated may produce some surprising information. **PTE**

#### For more information.

Visit [MotionIndustries.com/pte](http://MotionIndustries.com/pte) or download Mi's new and FREE Motors & Drives E-Book ([tinyurl.com/yb5a7cul](http://tinyurl.com/yb5a7cul)).

**Timothy Albers** is the director of product management for Nidec Motor Corporation's Commercial and Industrial Motor Division/US Motors. His current responsibilities include product management, product planning and new product development for the Commercial and Industrial motors. Albers has held various positions in marketing for Nidec Motor Corporation and Emerson Motor Company over the last twenty-two years, including product-line manager for NEMA motors. He is a senior member of IEEE and serves on many Hydraulic Institute technical committees. He also spent 12 years in active and reserve duty as a U. S. Navy officer, and was a qualified operating engineering officer.

**John R. Frese** is currently a vertical motor product manager for Nidec Motor Corporation. Since 1998, he has served in many sales and marketing roles for the Commercial-Industrial Motors and Drives Division of Nidec Motor Corporation (US Motors). Frese is a member of IEEE Standards Association, and serves on IEEE 841 and API 547 working groups. He received a bachelor of science degree in business administration from the University of Missouri – St. Louis.

**Glenn Martin** is the automation/electrical specialist for Motion Industries in the South Texas District. He provides technical and commercial support for all of the automation and electrical products that Motion Industries supplies to their customers in that area. Martin has been working with variable speed drives, electric motors, and automation products for over 40 years.

For Related Articles Search

cooling towers

at [www.powertransmission.com](http://www.powertransmission.com)



# WorldWide Electric Corporation

## Quality Products, Unprecedented Support

At WorldWide Electric, we believe that quality, reliable industrial motors, motor controls, and gear reducers don't have to be hard to get or over-priced. We strive to deliver affordable and dependable products quickly, and with unprecedented customer service.

WorldWide Electric's diverse product lines include electric motors, variable frequency drives, soft starters, motor controls, and gear reducers. In addition to the WorldWide Electric brand, we are also the exclusive master distributor and representative for Hyundai Electric's low-voltage electric motors and drives. Following the acquisition of Louis Allis in March 2020, WorldWide Electric added specialty motors to our already extensive product offering.

Quality assurance is a top priority at WorldWide Electric. In addition to being manufactured according to a stringent quality assurance program, WorldWide Electric products feature high end design elements like premium bearings in motors and case hardened, precision ground, A.G.M.A. rated gear sets in our gear reducers. Each year, we send



dozens of randomly selected motors to Advanced Energy Corporation, a third-party and internationally accredited lab, for Motor Build Inspection Analysis (MBIA) and performance testing. This unbiased inspection helps ensure that our customers are getting quality products they can depend on.

With \$30 Million in inventory at six regional US warehouses in Allentown, Atlanta, Dallas, Indianapolis, Los Angeles, and Seattle, we have the unique ability to ship most orders same day. Our ready-to-ship inventory even includes hard-to-find models that commonly require a special order from other manufacturers.

WorldWide Electric's unparalleled customer service and support keeps our customers coming back. Whenever you contact us, you will speak with a live person who is equipped to answer your questions and satisfy the specific requirements of your application. Our 24/7 after hours emergency support staff is also standing by to assist.

WorldWide Electric takes pride in providing a competitive edge to our customers by responding to their requirements with urgency, technical expertise, and professionalism. Learn more about all we have to offer at [www.worldwideelectric.net](http://www.worldwideelectric.net).



### FOR MORE INFORMATION

3540 Winton Place, Rochester, NY 14623

Phone: 800-808-2131

Email: [customerservice@worldwideelectric.net](mailto:customerservice@worldwideelectric.net)

[www.worldwideelectric.net](http://www.worldwideelectric.net)

# The Transparency Initiative

## Bosch Rexroth's Factory of the Future Aims to Improve Production Processes One Application at a Time

Matthew Jaster, Senior Editor

**It's February 2020 and 'Show and Tell' appears to be just as important today as it was back in the 1980s.** The Bosch Rexroth Factory of the Future exhibit in Hoffman Estates, Illinois — roughly 33 miles outside of Chicago — lets clients, guests and trade journalists see how the company is applying IIoT/Industry 4.0 technologies via real-time manufacturing applications. At first glance, the small exhibit hall is like a hands-on science lab where a variety of stations highlight what Bosch Rexroth is working on in areas like connectivity and distributed intelligence.

It's honestly a nice change of pace to go step-by-step and talk with Dave Cameron, director of sales at Bosch Rexroth - Automation and Electrification Solutions, and Arnie Mueller, director of operations and service at Bosch Rexroth Electric Drives and Controls, about how these IoT solutions are being implemented across the organization.

The *PTE* editors have read countless press releases on smart manufacturing and IoT in recent years, but the value of seeing exactly how these solutions benefit the factory floor certainly helps to imagine the tools a motor, bearing, or gear drive manufacturer will have at their disposal in the future.

### A History of IoT Innovation

Worldwide, Bosch Rexroth has more than 100 Internet of Things (IoT) projects running in a variety of industries and applications. The Bosch Rexroth drive and control technology engineers work on many of the Industry 4.0 technologies used in Bosch manufacturing facilities (including its own Rexroth factories).

This gives Bosch Rexroth the ability to test solutions within its "four walls" in real-world applications before making the products available to the

market, ensuring that only the highest-quality technological advancements are sold. In 50 plants across the globe, Rexroth manufactures products that put technology in motion, from hydraulic motors and pumps, to electric drives and controls, to linear motion and assembly technologies.

"At Bosch Rexroth, our differentiators are that we have open, smart devices (where controls, drives and motors become smart sensors) that offer the highest degrees of connectivity; for example, we use Multi-Ethernet and IO-Link in all our drive and control technologies," Cameron said.

In the Factory of the Future everything is connected, from field level to cloud-based IT systems. Rexroth automation solutions use open standards to enable the highest level of connectivity. Rexroth uses Multi-Ethernet and IO-Link in all drive and control technologies. All components, modules and machines will be able to exchange information with IT in real-time without having a central execution system (e.g., distributed intelligence). The result: Total transparency in the Factory

of the Future.

Main machine cabinets are not necessary in the flexible environment of a Factory of the Future. Decentralized intelligent automation components with integrated software perform their tasks independently according to the specifications of higher-level systems. For example, look at distributed intelligence with smart motor-integrated drives:

"We brought together a motor, drive and a sensor in one device - the Rexroth cabinet-free IndraDrive Mi. It's a motor-integrated device that eliminates machine cabinets and enables flexible machine and factory layouts. It also reduces cabling by 90%, energy consumption for cooling, frees up shop floor space leading to a reduced machine footprint. The IndraDrive Mi also has a powerful controller that acts as an intelligent sensor," said Mueller.

These communication/connectivity concepts give visitors an idea of what the smart factory floor will look like in the coming years.

"Our vision of the Factory of the Future offers complete flexibility. The

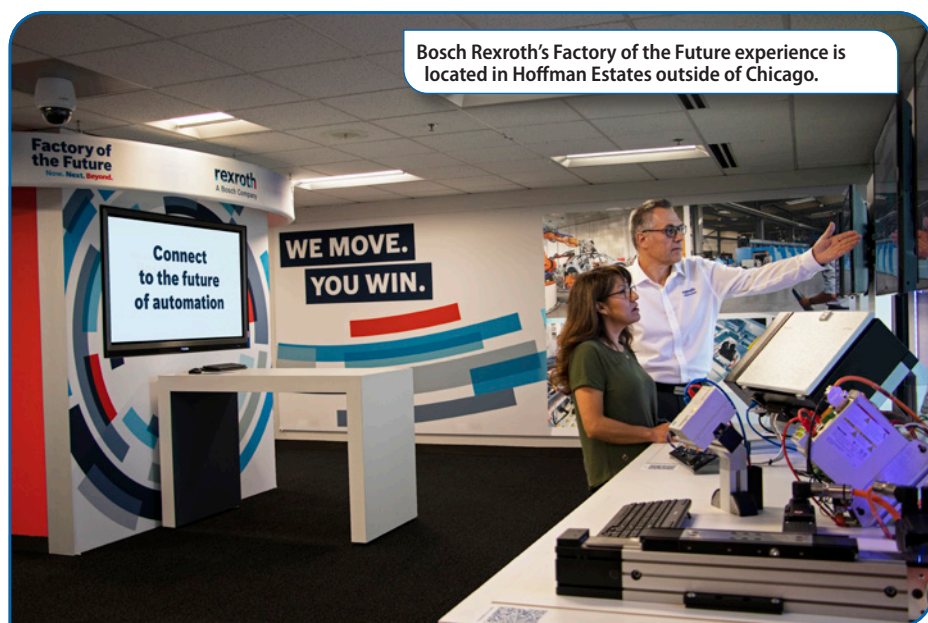



The flexibility of IndraDrive Mi contributes to cost reductions, reduced cabinet space and reduced energy consumption.

walls, the floor and the ceiling will all be fixed, but everything else will be mobile, with intelligent workspaces where equipment can move around independently. Power will be provided through the floor via inductive charging system,” Cameron said.

Assembly lines will be modular, and machines will move and reorganize themselves.

“In addition, machines and equipment will communicate wirelessly with one another and with other process functions via 5G. The backbone will be able to run a virtual production for planning and optimization. This will result in more flexibility to changing demands, which enables the production of small batches with new benchmarks in the cost-benefit ratio,” added Mueller.

### Real-World Examples

These Factory of the Future concepts are on display at the Bosch Rexroth facility outside of Chicago where visitors receive a backstage pass into how manufacturing communication is changing.

Highlights include:

**ActiveCockpit**—A networked IT application where production planning, quality data management and e-mailing with the software functionality of machines and plants is available directly on the shop floor providing real-time information.

“This puts a new spin on whiteboards by introducing technology so the group can incorporate team meetings, dashboards and visibility directly on the factory floor,” Cameron said.

**Cobots**—Shuttling parts throughout the factory and the introduction of collaborative robots (cobots) ramped up in 2018. Bosch Rexroth expanded

its portfolio of Automatic Production Assistants (APAS). This enables a simple and safe entry into the world of human-robot collaboration. Complete with capacitive sensor skin to avoid collisions, selectable control and the PLC interface mxAutomation, a six-axis robot can capture the strengths of both man and machine in the Factory of the Future.

**Transforming Legacy Products**—This demo in Chicago is a great starting point into IoT. Bosch took old machinery (a welding unit or drill, for example) and modernized it via gateways and sensors. Cameron said this allows you to take older, non-technical equipment and pull data off for operational benefits.

“We can measure vibration, light, humidity, temperature, etc.,” Cameron said. “The idea of taking data off an existing brownfield installation and using it to improve your production

process. Many huge OEMs, for example, have billions of dollars in capital investments and they cannot throw it all away in favor of new products. You have to offer products that adapt to the older equipment. Bosch makes sensors, software and gateways to be able to take this data and push it upstream.”

**Industrial IoT Gateways**—The Gateway is a device that takes in software data from existing motors, drives and controls and has all kinds of interfaces and gives you the ability to communicate with Oracle, Amazon or Bosch Rexroth’s own cloud service.

The idea is a device to push information through to another device. Taking a bunch of temperature, acceleration and machine data and sending this information into the cloud. “You’re not programming anything, you’re not interrupting the machine that was designed ten years ago, the gateway enables access to all kinds of information. This a market we’ve been involved in for a long time,” Cameron said.

**XDK Sensor Technology**—This universal programmable sensor device can be seamlessly integrated into the market’s most challenging IoT applications. There are new versions and new applications for sensing technology to measure data and evaluate productivity coming out regularly. It is also a great tool for IoT prototypes.

**Mechatronics**—Many of these innovations came out of Bosch’s Electrical Group in Chicago as well as the Mechanical Group in Charlotte and are being applied company-wide. Another example of electrical and mechanical principles coming together to solve the many daily challenges of manufacturing.

“The supply chain and operation side of our business is always evolving. Dedicated production lines to make a servo drive or a motor are transforming into production cells. I was used to seeing a dedicated production line for a product and suddenly the steps were all changing,” Cameron added. “This kind of flexible production is happening across all of our divisions.”

## Outside the Factory of the Future

My Chicago visit illustrated the many innovations happening on the shop floor today and tomorrow, but none of these technologies would be possible without the industry coming together to collaborate in areas like automation, security, network communication and IT (*Editor’s Note: See sidebar on page 35*).

“IoT and the realization of the Smart Factory depends on partners in the automation and IT area to make systems compatible and realize solutions. We have several partners, such as cloud providers (Microsoft, Oracle, Amazon), 5G and TSN (multiple automation companies) for example,” Cameron said.

OPC UA over TSN (Time-Sensitive Networking) is an example of how more than 25 participating companies are working together to provide Ethernet-based interoperability soon. “Oracle’s cloud interface and Java platforms are also examples’ of how we have solutions today in our products that are related to other partners,” he added.

Cameron said that technology creates a benefit through application. Applications can be remarkably diverse in manufacturing. Discovering

improvements in new applications helps feed new ideas back to technology ideas. “It’s like a circle,” he said.

## The Multi-Product Operation

Mueller and Cameron said that one of the most sophisticated operations is Bosch Rexroth’s industrial hydraulics manufacturing plant in Bethlehem, PA.

With a large building expansion in 2014, the Bethlehem facility produces valves and manifolds, industrial, mobile and compact controls and provides testing and service support. The distribution and logistics facility supports customers with functions such as shipping, receiving, logistics, quality control, traffic management and accounting. The company’s overall Bethlehem operations also include production for large hydraulic systems and power units. Customers served include those in the construction and agricultural mobile equipment industries, machine tools, presses, plastics machinery, die casting, marine and offshore, pulp and paper, specialty and test machinery, as well as its U.S. distributor network.

“The Bethlehem plant is proud to be one of the first Rexroth facilities worldwide to implement a full-scale manufacturing line using Rexroth’s



The IoT Gateway Rack has the ability to collect legacy PLCs and simple digital and analog I/O to collect data from machines that were manufactured without Industry 4.0 data transfer capabilities, making it the ideal solution for retrofitting older machines.

SafeLogic safely controls the drives for complex machines and plants, such as printing or packaging machines.



rapidly growing Industry 4.0 technology portfolio. The company's new Multi-Product Line (MPL) for assembling hydraulic components combines automated and manual systems with technology that connects operators, machinery and parts to make 34,500 different product variants. The result has been a significant increase in productivity, coupled with invaluable experience gained in the deployment of these forward-thinking technologies," Mueller said.

Within the MPL are a variety of impressive components that work in unison to provide Bethlehem plant management with the tools to keep up with the demands of the fourth industrial revolution. While using the MPL, the Bethlehem plant has experienced an impressive improvement in its production processes. Boasting an overall 2.8-year return on investment, the MPL has benefitted the plant with a 27% cycle-time reduction, 50% downtime-related maintenance and a 50% reduction in floor space.

"More importantly, most of the technology being utilized on the MPL is provided by Bosch divisions and are available for sale to other manufacturing customers," Cameron added.

### A Future of Disruption

New innovations in advanced sensors, data collecting, and the software capable of keeping up with it all, will determine how quick the paradigm will shift in manufacturing. How soon will the shop floor look more science fiction than science? What role will automation, augmented reality, artificial intelligence, and mixed reality play in the manufacture of motors, drives and controls? Bosch Rexroth is not waiting to find out. The company is taking steps in 2020 to prepare its manufacturing facilities as well as its customers for the disruptive technologies coming tomorrow.

It comes as no surprise that the organization is running these initiatives under the motto: Now, Next and Beyond. **PTE**

#### For more information:

Bosch Rexroth  
Phone: (800) 739-7684  
[www.boschrexroth-us.com/fotf-experience](http://www.boschrexroth-us.com/fotf-experience)

For Related Articles Search

IIoT

at [www.powertransmission.com](http://www.powertransmission.com)

## Bosch Rexroth Examines Mechanical Engineering Requirements with New Automation Platform

Thanks to the open and platform-neutral system architecture, ctrlX AUTOMATION offers the possibility to use future standards such as 5G, OPC UA over TSN, or programming languages yet under development as soon as they are ready for market, according to Dave Cameron, director of sales at Bosch Rexroth – Automation and Electrification Solutions,

"In the future, it will therefore also be possible for machine manufacturers and users to implement new types of automation concepts, whether intelligent AI systems, central server-based solutions, or distributed systems," Cameron said. "More than 30 direct connection options and communication standards offer maximum networking flexibility and enable end-to-end connectivity from field-level up to the cloud."

With this platform, Bosch Rexroth has eradicated the traditional boundaries between machine control systems, IT, and the Internet of Things. Centralized and decentralized automation topologies can now be created flexibly with the scalable platform. Thanks to a Linux real-time operating system, open standards, app programming technology, web-based engineering and a comprehensive IoT connection, ctrlX AUTOMATION reduces the engineering time and effort by 30% to 50%.

Today, mechanical engineering is based on software development. Bosch Rexroth's new ctrlX AUTOMATION platform addresses this market requirement, encompassing the latest engineering software technologies and all PLC and motion tasks. Software functions are combinable in any

number of ways with ready-made, customized and customizable apps. These apps can be created in a variety of programming languages such as C++, script languages such as Python or new graphical languages such as Blockly. This gives machine manufacturers new-found freedom.

The system is set up to allow for personalization and customization. Users decide whether to program in IEC 61131, PLCopen or G-Code, or in other conventional high-level or Internet languages. This liberates machine manufacturers from dependency on the availability of PLC specialists and proprietary systems.

Configuration and commissioning of automation components is completely web-based, eliminating the need to install software. Within minutes of switching on the system, the software is programmed. A completely virtual ctrlX AUTOMATION system environment is available, enabling programming without hardware. System functionalities can be extended at any time via the user's own process functions, apps, and open-source software. In total, ctrlX AUTOMATION cuts the engineering time and effort by 30% to 50%, which significantly reduces time to market for new machines.

This platform is based on a new generation of multicore processors which provide sufficient processing power for almost all automation tasks. These high-performance CPUs

can be integrated into embedded PCs and industrial PCs, or directly into drives. The all-new hardware and software module will cover all automation tasks – from simple control applications and IoT solutions to high-performance motion control.

And what might be one of the more welcoming features of the new automation platform is the lighter, smaller controller and its inherent adaptability. CIMCORP provides automated robotic solutions for the logistics market and is also an early adopter of the ctrlX AUTOMATION system.

Jyrki Anttonen, technology director at CIMCORP, said the company signed an agreement to become a lead customer due to their existing relationship with Bosch Rexroth products and services. As mentioned

earlier, the lighter, smaller controller was an immediate benefit to CIMCORP as well as the open nature of the controller to the IT world, which plays a huge role in future control system architecture.

It gave CIMCORP a unique opportunity to influence the development of ctrlX AUTOMATION. From the outset, they shared system requirements with Bosch Rexroth. By being able to implement the product early, CIMCORP has a head start, which gives the company a significant competitive advantage. It also gives the organization an opportunity to influence the development and offer feedback of ctrlX AUTOMATION through collaboration. **PTE**



For Related Articles Search

motion control

at [www.powertransmission.com](http://www.powertransmission.com)



# ADVANCED 100% SYNTHETIC GEAR OILS

**FROM A COMPANY ADVANCING  
LUBRICATION FOR 150 YEARS**

150 years ago, our founders set out to make the highest quality, best performing lubricants available. In doing so, they helped pioneer the use of anti-wear additives that significantly increased lubricant performance through the years. Today, that innovative tradition continues with our newest line of ultra high-performance, 100% synthetic gear oils. These new lubricants provide a wide range of benefits including: extended fluid change intervals, cooler operating temperatures, reduced friction and reduced downtime.

Products include...

**SYN LUBE SERIES 150 - 1000**

High performance, fully compatible PAO-based gear oils.

**SYN LUBE HD SERIES**

Heavy-duty, (EP) extreme pressure, PAO-based gear oils.

**SYNTHETIC WORM GEAR LUBRICANT**

High performance, ISO 460 Grade, PAO-based worm gear oil.

**PGO SERIES**

Ultra high-performance, PAG-based gear oils.

**PGO-FGL SERIES**

NSF H1 registered, food machinery grade, PAG-based gear oils.

**SFGO ULTRA SERIES 150 - 1000**

NSF H1 registered, food machinery grade, PAO-based gear oils.

QUALITY  
INNOVATION  
PERFORMANCE  
FOR 150 YEARS



CELEBRATING  
**150** YEARS  
OF QUALITY, INNOVATION  
AND PERFORMANCE

**LUBRIPLATE LUBRICANTS COMPANY**  
NEWARK, NJ 07105 / TOLEDO, OH 43605 / 800-733-4755  
LubeXpert@lubriplate.com / www.lubriplate.com



INCLUDED AT NO ADDITIONAL CHARGE



**Complimentary Extra Services Package**

COLOR CODED LUBE CHARTS & MACHINERY TAGS  
PLANT SURVEYS / TECH SUPPORT / TRAINING  
LUBRICATION SOFTWARE / FOLLOW-UP OIL ANALYSIS

## High Performance Bevel Gearboxes

The Tandler Spiral Bevel gearbox is both precise and ideal for demanding applications where robustness and high torque density are required.



- 9 sizes
- Low backlash
- 15 ratios
- Customizable

**DIEQUA**  
Corporation

[diequa.com/pte](http://diequa.com/pte) 800-430-1439

## Inline Helical Speed Reducers

An extremely compact design provides highly reliable, space saving performance for the most demanding applications.



- 14 sizes, 1 - 75 HP
- Multi-stage Ratios
- NEMA, IEC, or Servo Motor Adapters
- High Efficiency & Low Backlash
- Multiple Mounting Configurations

**DIEQUA**  
Corporation

[diequa.com/pte](http://diequa.com/pte) 800-280-5402

## Engineering sMart

is your resource for the latest in great ideas from our advertisers. Check this section every issue for sMart Engineering ideas and technology.

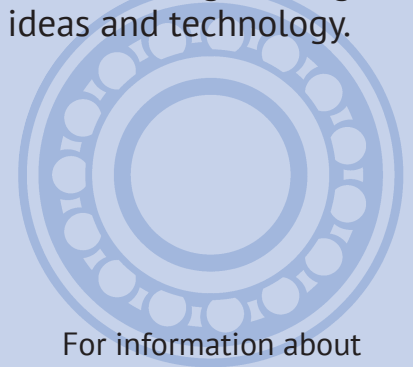

For information about advertising, contact

Dave Friedman  
at

(847) 437-6604

or

[dave@powertransmission.com](mailto:dave@powertransmission.com).

## Precision Mechanical Components & Assemblies

Standard Industrial Components | Made To Print Parts

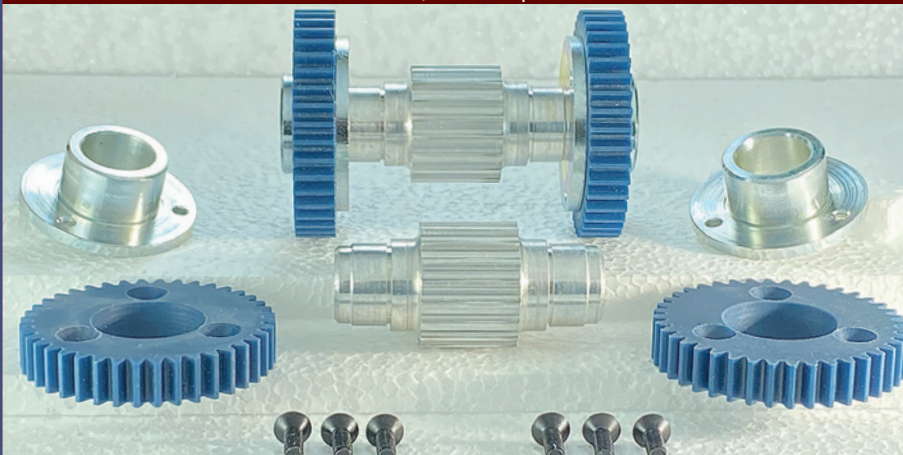

Gears, Pulleys, Shafts, Bearings, Couplings, Fasteners, Custom Gear Boxes  
Value Added Features and Services

Engineering, Refurbishing & Design  
Custom Made To Print Parts  
Modified Standard Parts  
Assemblies & Sub-Assemblies  
Custom Mounts For Shafts  
Build Sub-Assemblies And Complete Assemblies  
Prototype Work

- ▶ Press bearings into pulleys
- ▶ Assemble bearings to shafts
- ▶ Set backlash on gears
- ▶ Assemble drive boxes
- ▶ Straightening
- ▶ Welding
- ▶ Kitting
- ▶ Plating / Custom Coating
- ▶ Heat treat

ADD

- Grooves • Flats • Keyways • Pins
- Threads • Staking • Pressing
- Testing

**Nordex**  
INCORPORATED

[Nordex.com](http://Nordex.com) [Sales@nordex.com](mailto:Sales@nordex.com) [Eng@nordex.com](mailto:Eng@nordex.com)  
Phone: (800) 243-0986 or Call: (203) 775-4877

## Subscribe TODAY



IT's FAST. IT's EASY.  
IT keeps YOU in the KNOW.

[www.powertransmission.com/subscribe.htm](http://www.powertransmission.com/subscribe.htm)



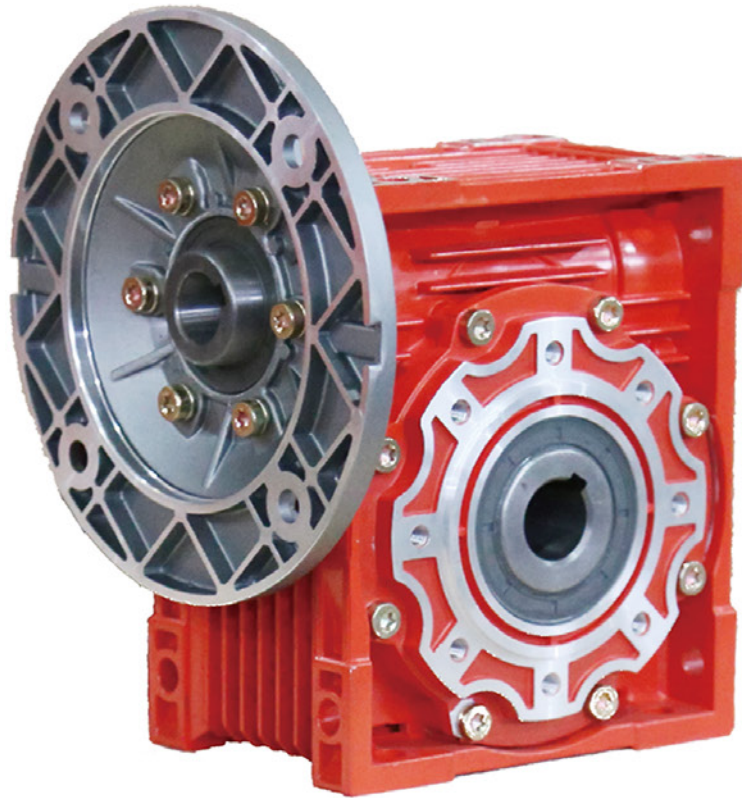

## **JRW WORM GEAR UNIT**

Same Day Delivery

NSK Bearing & SKF Seal

IEC & Servo Adapters Available

Size: 30-150

Ratio: 5-100

Input Power: 0.08 -20HP

Output Torque: 23-15580lb-in

[www.jie-drives.com](http://www.jie-drives.com) | [info@jie-drives.com](mailto:info@jie-drives.com) | 630 580 9986  
493 Mission St Carol Stream IL 60188 USA



## Watch *Power Transmission Engineering TV*

[www.powertransmission.com/tv/](http://www.powertransmission.com/tv/)



**Learn Something  
New Today!**



A wireframe funnel, resembling a time machine or a wormhole, is positioned vertically in the center of the page. At the top opening of the funnel, a small Earth is visible. At the bottom opening, a larger Earth is shown. The background is a dark space filled with a vibrant red nebula and numerous white stars. In the upper left and lower right corners, there are smaller, distant Earths.

# **GREAT SCOTT!**

## ***It's the future!***

**OK, you blinked and missed last month's issue of *Power Transmission Engineering*.** Fortunately, you don't need a DeLorean to travel back in time — just a computer and working fingers.

Hop online and visit [www.powertransmission.com](http://www.powertransmission.com) to view the entire magazine, including these exclusive features:

- Tackling Fluid Power Challenges
- A Mechatronic State of Mind
- Gearmotors Handle Harsh Environments
- Motor Sizing Unusual Loads

**...and much more!**

[www.powertransmission.com](http://www.powertransmission.com)

# Dynamic Behavior of Planetary Gears

Dr.-Ing. Burkhard Pinnekamp, Dr.-Ing. Michael Heider, and M.Sc. Andreas Beinestingel

## Introduction

Besides power density, reliability and efficiency, noise is always an important criterion for a successful gear design. In many theoretical and experimental investigations and papers, the influences and potential remedies were discussed. For example, in (Ref. 6) the importance of a large overlap ratio, achieved by a large helix angle is described as the most important factor for reducing gear noise. In planetary gear systems of high power density and high gear ratio, helical gears create undesirable tilting moments on the planet gears; therefore, spur gears are still preferred for planetary gears—a special challenge with respect to noise. Specifically, the different behavior of planetary gears with sequential and symmetric gear mesh is explained in this paper.

As described (Ref. 10), the variable mesh stiffness along the path of contact leads to oscillating forces on the shafts and bearings, which are transmitted to the casing. The casing vibrations radiate airborne noise (Fig. 1).

The influence of tooth geometry on the excitation behavior is determined by the geometry parameters, such as profile and overlap ratios, flank modifications and manufacturing deviations. For design to low noise emission, the knowledge of the elastic and dynamic behavior of the transmission system and the excitation mechanisms of the gear mesh is required. Parameters which are useful to evaluate the dynamic behavior of a gear mesh are described in this paper.

The findings of (Ref. 10) are summarized in this paper, further developed and, for sequential gear mesh, applied to a practical example with test stand measurements. Hereby, the theory is

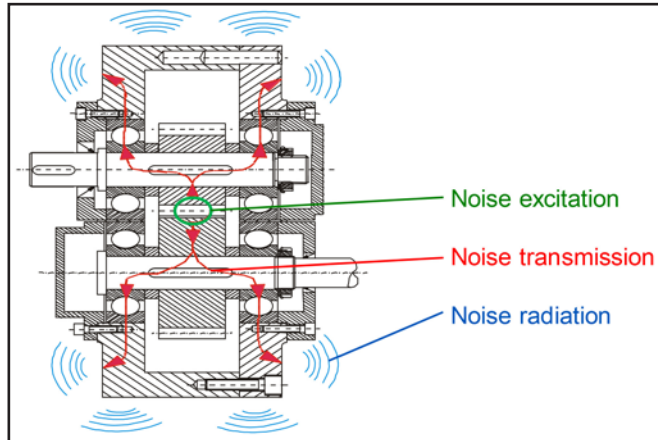

Figure 1 Noise: generation, transmission and radiation.

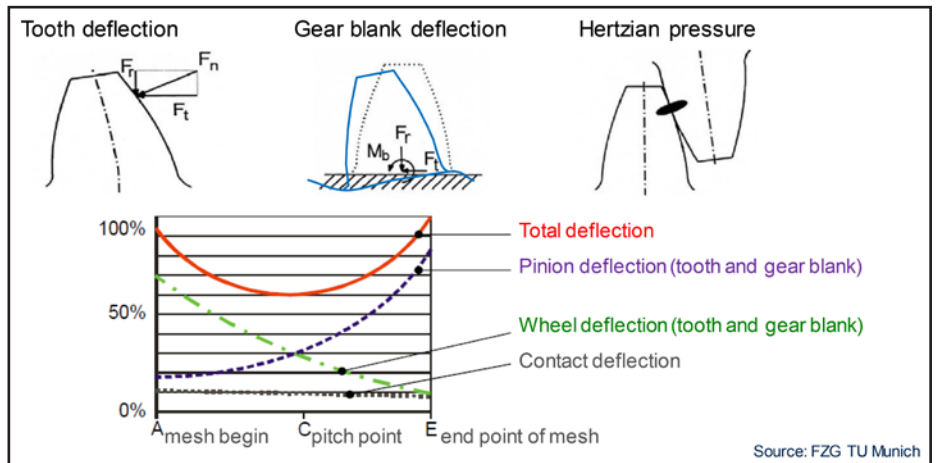

Figure 2 Contributions to single tooth contact deflection along path of contact (Source: FZG TU Munich).

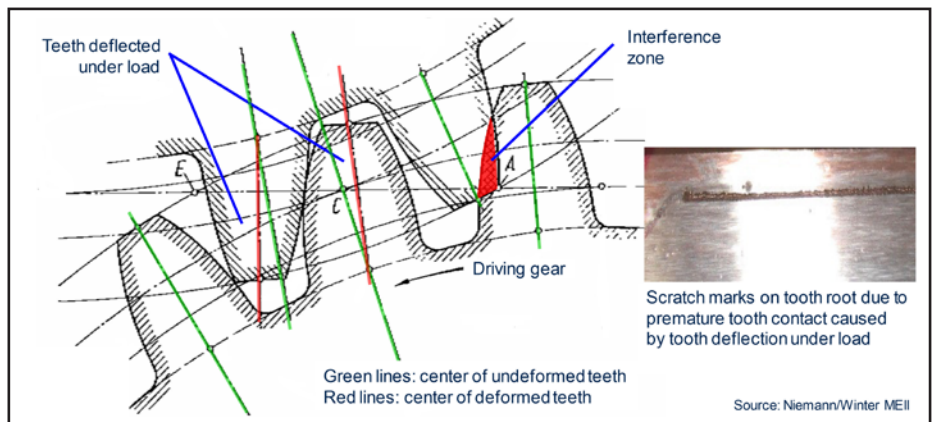

Figure 3 Interference due to tooth deflection under load (Source: Niemann/Winter MEI).

Printed with permission of the copyright holder, the American Gear Manufacturers Association, 1001 N. Fairfax Street, Fifth Floor, Alexandria, VA 22314-1587. Statements presented in this paper are those of the author(s) and may not represent the position or opinion of the American Gear Manufacturers Association.

further sustained on how several variables impact gear noise in parallel shaft and planetary gear trains.

## Gear Mesh Excitation

For a cylindrical, involute gear mesh, the main parameters of excitation are:

- Time-varying tooth stiffness
- Deflection of the teeth
- Deviations in tooth geometry
- Deflection of shafts, bearings and casing
- Premature tooth contact under load

### **Tooth deflection and mesh stiffness.**

Single tooth mesh stiffness consists of three components as depicted in Figure 2:

- Tooth deflection due to bending under load
- Bending deflection of the gear blank or gear rim
- Contact deflection of surfaces under Hertzian stress

Even with close to perfectly manufactured gear geometry, due to this elastic deformation under load, the flank position will shift relative to the theoretical unloaded position (Ref.5). There will be interference between the gear teeth with the subsequent, not-yet-loaded gear teeth, which are about to enter the mesh (Fig.3), causing periodic noise excitation. This interference can be compensated for by appropriate profile modification, which only can be optimized for one load level. If not addressed appropriately, the subsequent teeth will come into contact prematurely outside the path of contact (“premature gear mesh”) and may cause stretch marks (Fig.3).

**Dynamic excitation.** Even with perfect profile modification preventing an interference between the mating gear teeth entering the gear mesh, the total mesh stiffness varies considerably along the path of contact. This is caused by the influences as described in Figure 2 and, moreover, in the change between single and double tooth contact along the path of contact. Especially for spur gears, two indicators for excitation can be derived from this change of stiffness (Fig.4):

- **Transmission error**, which is the static deflection between pinion and wheel under load, ignoring mass acceleration forces, and describes the oscillation of output speed at

constant input speed.

- **Force excitation**, which is the maximum dynamic force created by the transmission error without compensating movement of masses (i.e., rigid masses). It may be used as the force parameter to evaluate the level of excitation, but does not, however, consider the real dynamic system.

Mesh stiffness, transmission error and force excitation are shown (Fig.4) for a spur gear pair without flank corrections. The mesh stiffness (red line) herein is defined from the ideal involute. The transmission error (blue line) represents the angular position difference from uniform transmission. The

effects of excitation can be seen significantly in this curve. Additionally, the force excitation (green curve) represents the mesh force when rolling pinion and wheel are at perfectly constant speed, as defined by the gear ratio. In addition to the time-dependent curves, the referring spectra are shown.

These values can also be used to evaluate influences of deviations or microgeometry modifications; therefore their description in an accurate way is necessary. The curves in Figure 5 (left side) are for a spur gear pair with pitch deviation. The amplitude of harmonics of mesh frequency are high and a low-frequency excitation is added. In Figure

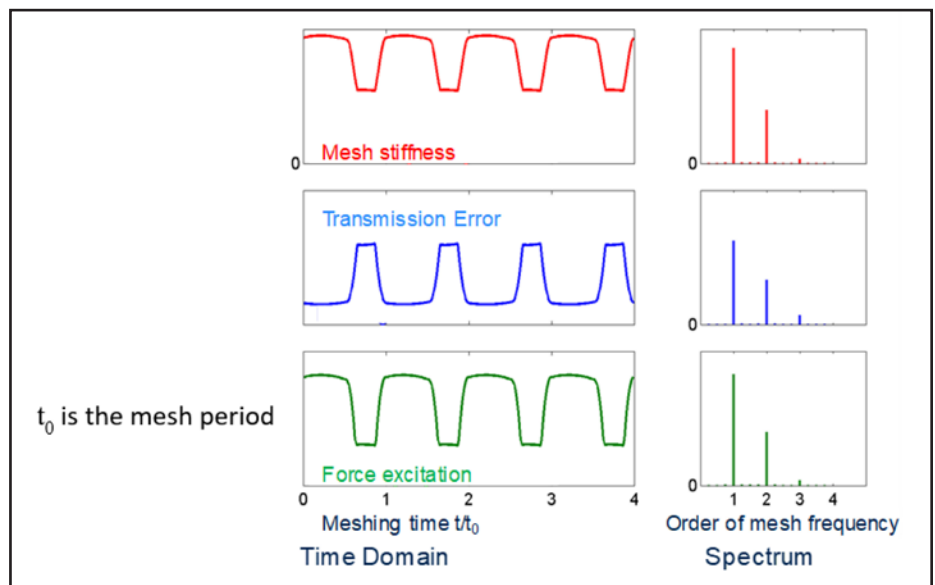

Figure 4 Characteristic parameters for spur gear with unmodified involute profile.

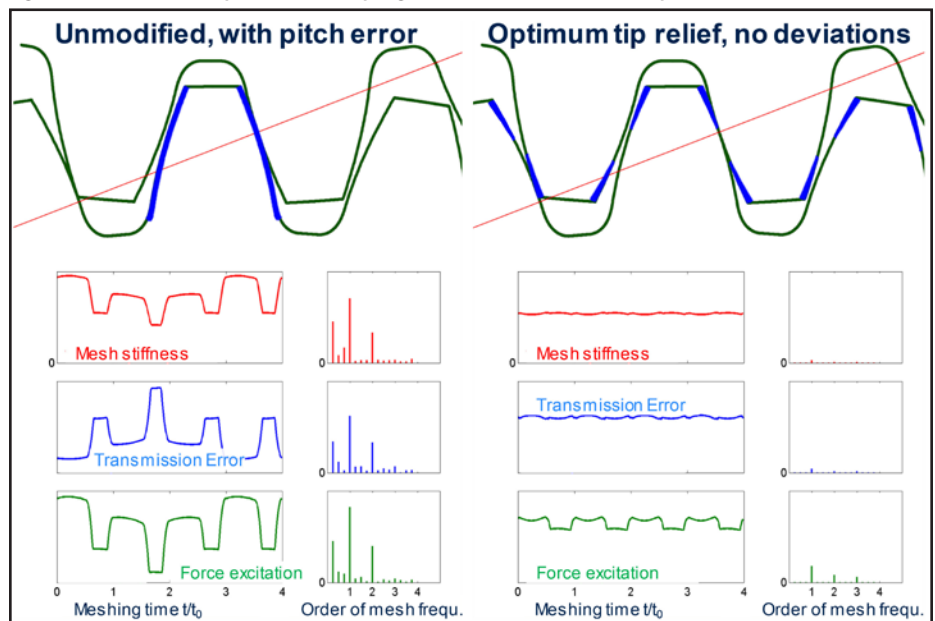

Figure 5 Influence of pitch deviation and profile modification on the characteristic parameters for a spur gear mesh.

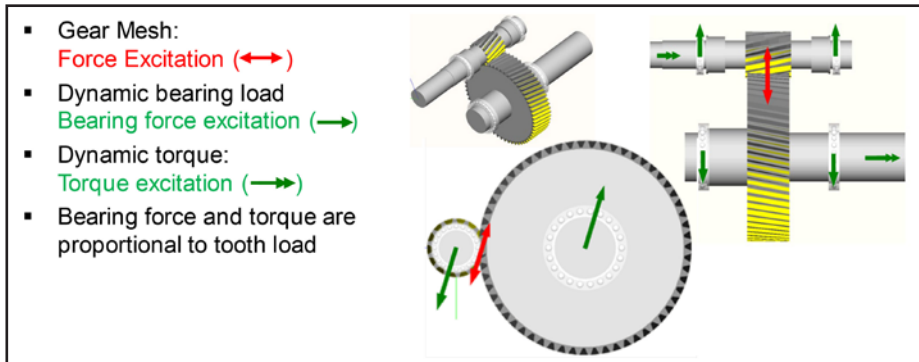

Figure 6 Dynamic excitation in helical gear stage; rotational and lateral dynamic effects are coupled.

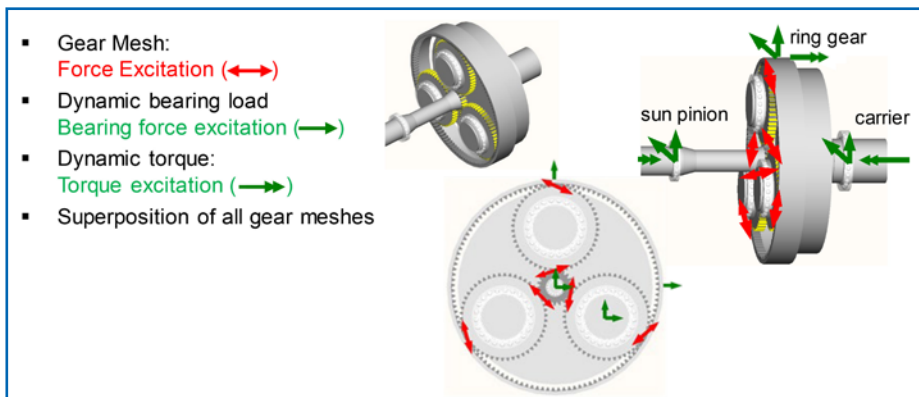

Figure 7 Dynamic excitation in planetary gear stage; rotational and lateral dynamic effects are not coupled.

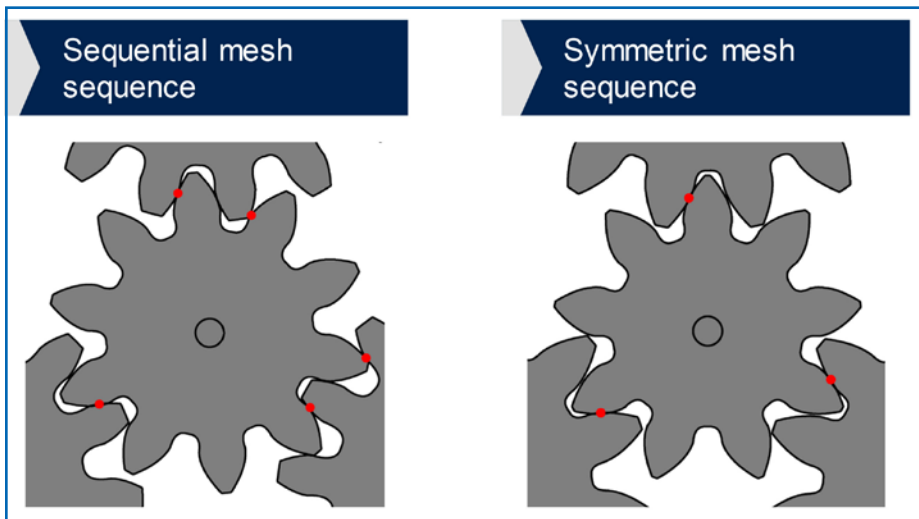

Figure 8 Mesh sequence in planetary gear stage.

5 (right side), the curves for the same mesh are shown without pitch deviation and with optimized profile modification. All values show significant improvements of excitation with considerably smaller amplitudes.

### Excitation Modes for Cylindrical Gear Stage and Planetary Gear Stage

For a parallel offset gear stage, one gear mesh is subject to transmission error and force excitation. This excitation causes both oscillating bearing load and shaft torque, where load and torque are synchronous and both proportional to the excitation. Rotational and lateral dynamic effects are therefore coupled (Fig. 6).

This is different with planetary gear stages as the sun pinion is in mesh with multiple planet gears simultaneously. The excitation of all meshes is superposed on the sun pinion. This superposition may be favorable or unfavorable:

- The *lateral excitation* of the sun pinion causing lateral vibrations and dynamic bearing load is determined by the sum of all force vectors of the individual meshes. To keep lateral excitation to a minimum, *all mesh forces should be equal* at any time and hereby fully balanced.
- The *rotational excitation* of the sun pinion causing torsional vibrations is determined by the sum of torque created by all gear meshes. To keep torsional excitation to a minimum, *the scalar sum of all mesh forces should be equal* at any time.

Both requirements are in contradiction; for planetary gears, rotational and lateral dynamic effects are not coupled (Fig. 7).

### Influence of Mesh Sequence in Planetary Gear Stages

The result of the superposition of force excitation in the individual gear meshes of a planetary gear stage strongly depends on the phase of the mesh excitations to each other. An important parameter is the mesh sequence which is the phasing between the individual meshes. For equally spaced planets, it can be distinguished between:

- **Symmetric mesh sequence:** number of teeth of the sun pinion is divisible by number of planets. All meshes are at the same point on the path of contact at any time.
- **Sequential mesh sequence:** number of teeth of the sun pinion is not divisible by number of planets. The meshes are at different points on path of contact at any time (Fig. 8).

**Planetary gear stage with sequential mesh sequence.** Figure 9 shows the force excitation and the torque excitation of the sun pinion for a planetary gear stage with sequential mesh sequence. The individual meshes are distinguished by different colors; they show the typical phase offset for sequential mesh sequence. There are always two meshes in single contact area (low force) and one mesh in double contact area (high force). In the schematic drawings, all radial forces on the sun pinion are shown for the indicated point in time. There is always one force higher than the other two, thus leaving a radial force in alternating directions (black arrows); the total torque, however, is constant at any time.

**Planetary gear stage with symmetric mesh sequence.** Figure 10 shows the force excitation and the torque excitation of the sun pinion for a planetary gear stage with symmetric mesh sequence. The individual meshes are theoretically shown in the same different colors (Fig. 9). As there is no phase offset, all curves are identical and cannot be distinguished. They show the typical synchronous phase for symmetric mesh sequence. All meshes are either in single contact area (low force) or in double contact area (high force) at the same time. In the schematic drawings, all radial forces on the sun pinion are shown for the indicated point in time. The force vectors always balance to zero; however, the total torque alternates periodically.

**Comparison of symmetric and sequential mesh sequence.** It can be derived from the statements in the previous paragraphs that either lateral excitation (with symmetric mesh sequence) or torsional excitation (with sequential mesh sequence) can be optimized by just the selection of mesh sequence. The comparison is shown in Figure 11 and Figure 12.

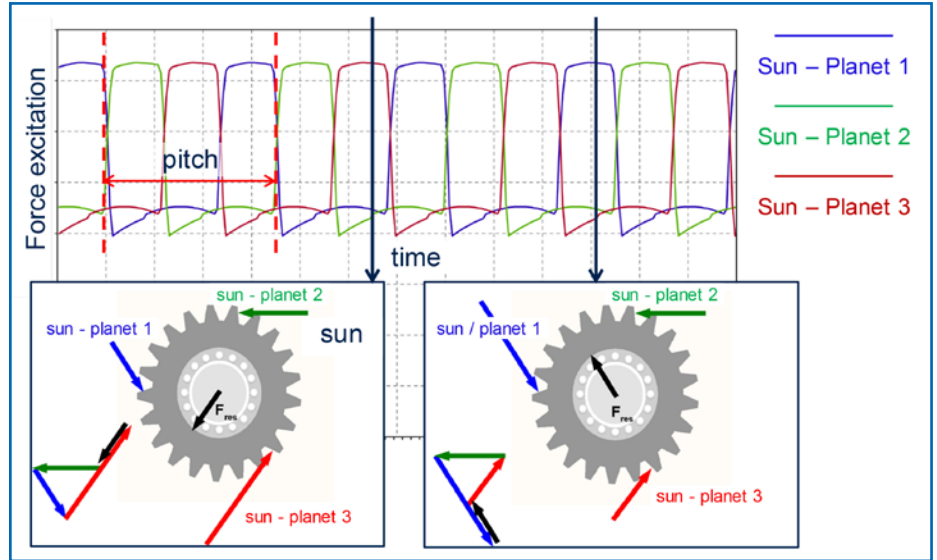

Figure 9 Force excitation of meshes sun-planet (unmodified spur gears); sequential mesh sequence.

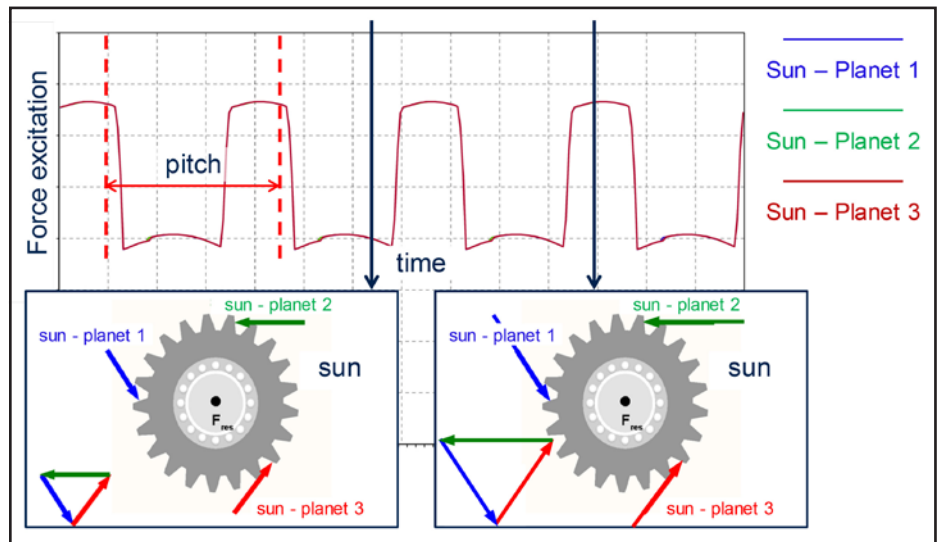

Figure 10 Force excitation of meshes sun-planet (unmodified spur gears); symmetric mesh sequence.

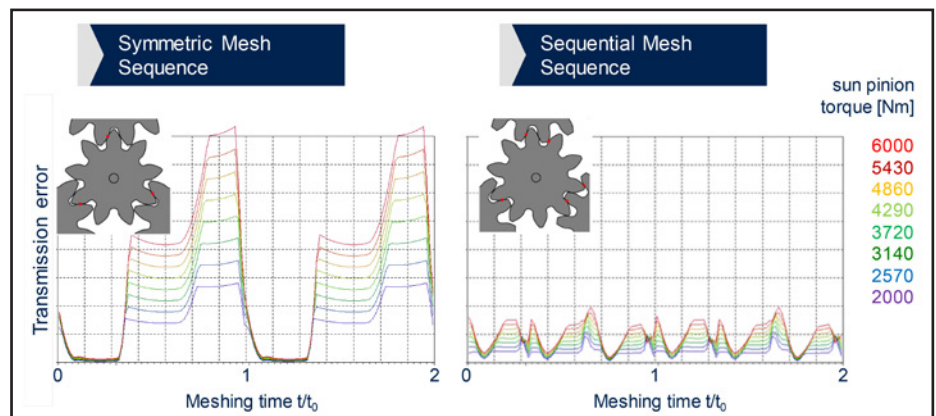

Figure 11 Transmission error between sun and ring gear (unmodified) — torsional excitation.

The only remedy to reduce both excitation modes to a minimum is to reduce the actual transmission error by optimum profile modification as shown on the right side of Figure 5. Profile modification should preferably be done by tip relief on both mating gears. The amount of tip relief depends on tooth deflection and therefore depends on load. Tip relief does not change natural

frequencies.

### Practical Example for Optimizing a Planetary Gear

For a practical application, two different sets of sun pinion and planet gears were used on a test bench—one with appropriate profile modification and one without. The different noise excitation levels were validated by measure-

ment of casing vibrations at increasing speed without generator load. The gear is for a 6 MW power plant application where a steam turbine (11,000 rpm) runs a generator (1,500 rpm) via the reduction planetary gear (Fig. 13).

The original gear design started with the typical selection of macrogeometry parameters such as module, number of teeth, contact ratio to match the requirements with respect to specification and load carrying capacity. The gear mesh frequency,  $f_z$ , is rated as:

$$f_z = \frac{(n_{sun} - n_{carr}) * z_{sun}}{60^{sec/min}} \quad (1)$$

where

- $n_{sun}$  is the sun pinion speed in rpm
- $n_{carr}$  is the planet carrier speed in rpm
- $z_{sun}$  is the number of teeth of the sun pinion

For the actual application, 23 teeth on the sun pinion result in sequential mesh sequence. With the planet carrier being at a standstill, and an input speed of 11,000 rpm, a tooth mesh frequency of 4,217 Hz is calculated. With this frequency, interference with natural frequencies (from lateral and torsional vibrations calculations) is avoided.

Figure 14 shows the actual test setup, where both gear sets, with and without profile modification were installed for testing. Measurements of casing vibrations were taken and plotted in waterfall diagrams ramping the speed up from zero to 105% of nominal speed without generator load. Figure 15 shows the resulting waterfall diagrams for the modified (left diagram) and unmodified (right diagram) gear set. It can clearly be seen that the overall vibration level is much greater with the unmodified gears—especially the mesh frequency and its second and third orders. This effect is predominant because of the strong lateral excitation for sequential mesh sequence.

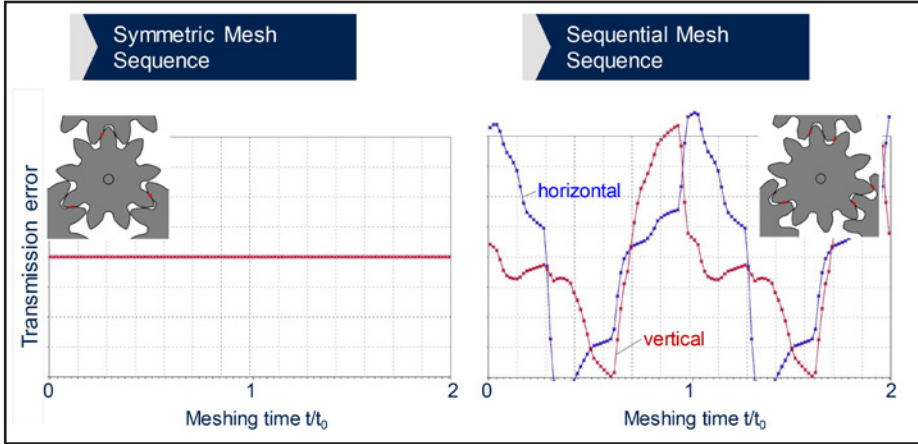

Figure 12 Radial displacement of sun pinion (unmodified) — lateral excitation.

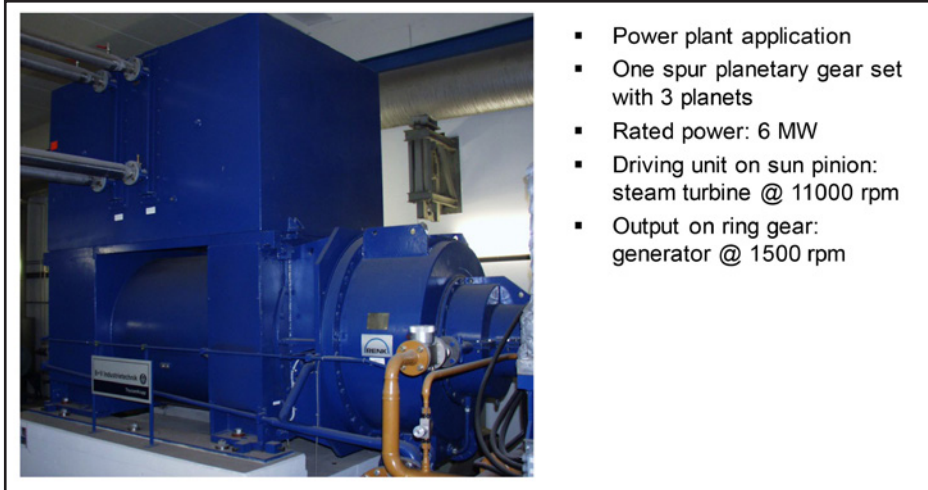

Figure 13 Gear application for testing — main data.

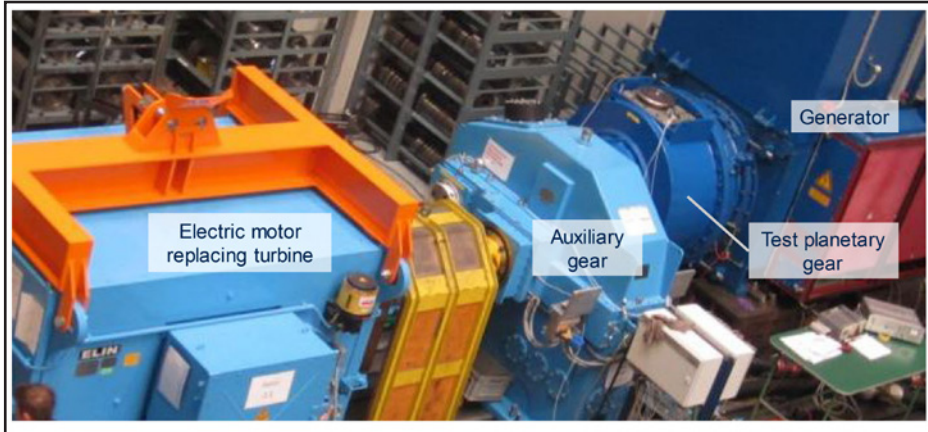

Figure 14 Test setup.



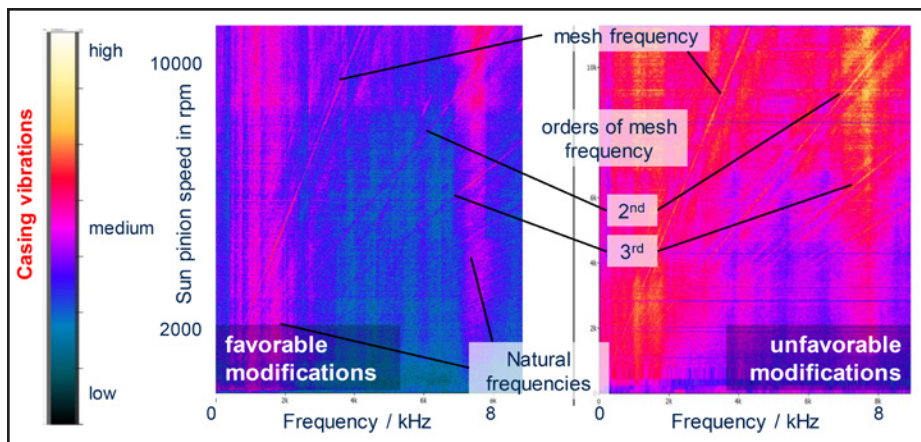

Figure 15 Speed ramp; measurement of casing vibrations.

## Conclusions

- Decisive parameters for the dynamic behavior of a gear mesh are transmission error and force excitation.
- Superposition of these parameters for planetary gears (three planets) leads to the following specific aspects:
  - Independent radial load and torque excitation
  - Gear geometry deviations and profile modification have a strong impact on the excitation level
  - Best remedy is low mesh excitation level
- Influence of mesh sequence:
  - For sequential mesh sequence, radial excitation is predominant; choose if torsional vibration excitation needs to be minimized
  - For symmetric mesh sequence, torsional excitation is predominant; choose if lateral vibration excitation needs to be minimized
- Practical example with sequential mesh sequence confirms the impact of profile modification on the vibration excitation level.
- Comparison of sequential and symmetric gear mesh could so far not be validated by testing. This should be done with the next suitable opportunity. **PTE**

### For more information.

Questions or comments regarding this paper? Contact the authors at [info@renk.biz](mailto:info@renk.biz).

For Related Articles Search

planetary gears

at [www.powertransmission.com](http://www.powertransmission.com)

## References

1. Oster, P. *Influence of Overlap Ratio on Noise Exciting Level*, Research program of FVA 58/T252, 1985.
2. Palmer, Fuehrer. "Noise Control in Planetary Transmission," SAE Paper No. 770561, April 18-20, 1977.
3. Müller, R. "Vibration and Noise Excitation with Toothed Gears," Dissertation at Technical University, Munich, 1991.
4. Hofmann, D.A., J. Haigh, and Lt. I. Atkins, "The Ultra-Low Noise Gearbox," *Transactions of INEC 2000*, Hamburg, March 2000.
5. Niemann, G. and H. Winter. *Maschinenelemente Band II*, Springer Verlag, Berlin Heidelberg New York (English).
6. Hoppe, F. and B. Pinnekamp. "Challenge and Success Based on Optimized Gear Geometries," *AGMA Fall Technical Meeting*, October 24-26, 2004, Milwaukee, WI.
7. Griggel, T., M. Heider and J. Bihl. FVA-Heft 937: FVA-Forschungsvorhaben 338 V, DZP / DZPopt, DZP Version 5.0 und DZPopt Version 2.0 / *Forschungsvereinigung Antriebstechnik e.V. (FVA)*; Frankfurt/Main, 2010 - *Abschlussbericht*.
8. Heider, M. FVA-Heft 968: FVA-Forschungsvorhaben 292 II, *Anregungsoptimaler Planetenradsatz: Software zur Optimierung des Anregungsverhaltens eines Planetenradsatzes / Forschungsvereinigung Antriebstechnik e.V. (FVA)*. Frankfurt/Main, 2011 - *Abschlussbericht*.
9. Heider, M. "Schwingungsverhalten von Zahnradgetrieben," Dissertation at Technical University, Munich, 2012
10. Heider, M., J. Bihl, M. Otto, B.-R. Hoehn and K. Stahl. "Vibration Excitation of a Planetary Gear Stage," *International Conference on Gears*, Munich, Garching, October 7-9, 2013.
11. Heider, M., B. Pinnekamp and A. Beinstingel. "Planetary Gears: Excitation Modes, Noise and Modifications," *International Conference on Gears*, Munich, September 18-20, 2019.

### Dr.-Ing. Burkhard Pinnekamp

earned his degree in mechanical engineering in 1987, and a Ph.D. in 1992 at the Gear Research Center (FZG), Technical University Munich. He continued work at FZG as chief engineer in the field of continuously variable transmission and hybrid car propulsion systems. From 1996 to 1999, he was deputy chief designer with the design department for marine gears at RENK AG, Augsburg. From 1999 to 2001, he headed the design department for industrial gears and, from 2001 to 2004, he led the design department for high-speed gears at RENK AG, Augsburg. From 2004 to 2006, he continued with RENK Corporation, USA, for various marine and industrial gear programs. Since mid-2006, Pinnekamp has served as head of the Central Technology division at RENK AG, Augsburg, focusing on gear calculation, programming, structural and dynamic analyses and innovation management.



### Dr.-Ing. Michael Heider

earned a degree mechanical engineering in 2006 and a Ph.D. in 2012 at the Gear Research Center (FZG), Technical University Munich. He continued work at FZG as team leader for gear dynamics and calculation. From 2014-2016, he was senior engineer at the Central Technology Division of RENK AG, Augsburg, focusing on gear calculation, programming, structural and dynamic analyses. Since 2016 Heider has been team leader for calculation at the Central Technology Division for RENK.



### Andreas Beinstingel

is a computational engineer for industrial and marine gears with a focus on structural dynamics and acoustics. He holds a bachelor degree in mechanical engineering from Augsburg University of Applied Sciences, and a master degree in computational engineering from Munich University of Applied Sciences. He joined the transmission industry at the beginning of 2015 at RENK AG Augsburg as a software developer in the field of structural mechanics. Since 2018, Beinstingel has also been working as an external Ph.D. student at the Chair of Vibro-acoustics of Vehicles and Machines (VIB) at the Technical University of Munich (TUM). The research partnership between RENK AG Augsburg and TUM includes the investigation of the excitation behavior of involute gears under operating conditions within its mathematical implementation in simulation algorithms.



# Combining Gear Design with Manufacturing Process Decisions

Dr. Ing. U. Kissling, Ing. U. Stolz and Dr. Ing. A. Türich

## Introduction

The layout of gear drives is a challenging process. Lifetime, noise, losses and other criteria must be considered. In the design process, first the overall geometry (e.g., center distance and outer

dimensions of gear pairs) must be determined. Then macro geometry (e.g., module, helix angle, number of teeth, and reference profile) must be defined and optimized based on the requested design requirements. Finally, the micro

geometry (e.g., profile and lead modifications) must be sized for optimum gear mesh behavior.

In this complex process a design engineer is focused on finding the best gear layout and will not often consider manufacturing constraints. It's only after the manufacturing department gets the gear design data that the most efficient manufacturing process is evaluated and manufacturing costs are considered. Today cost-efficient gear manufacturing processes are available. But whether a process—for example, power skiving or honing—is possible or not depends on certain gear and pinion geometry conditions and interference contours. Often, only a small change in the macro geometry would permit the use of a more productive or less-costly manufacturing process.

If the production department requests a change to the gear geometry, the design process often must be restarted, making the process time-consuming. Instead, an often-repeated request from production departments is to integrate certain manufacturing experience into the design process. Frequently designers are not familiar with manufacturing processes and so it is beneficial for them to have access to simple manufacturing information within their design software. This can, for example, determine if an intended manufacturing process is feasible or not.

## Selection of Available Tools during the Gear Design Process

*Choice of cutter or gear shapers.* For companies producing special gearboxes in single-unit or small batches, costs can be reduced if existing tools such as hobs or shaper cutters can be reused. The design software can present a list of available tools when the gear geometry (ref-

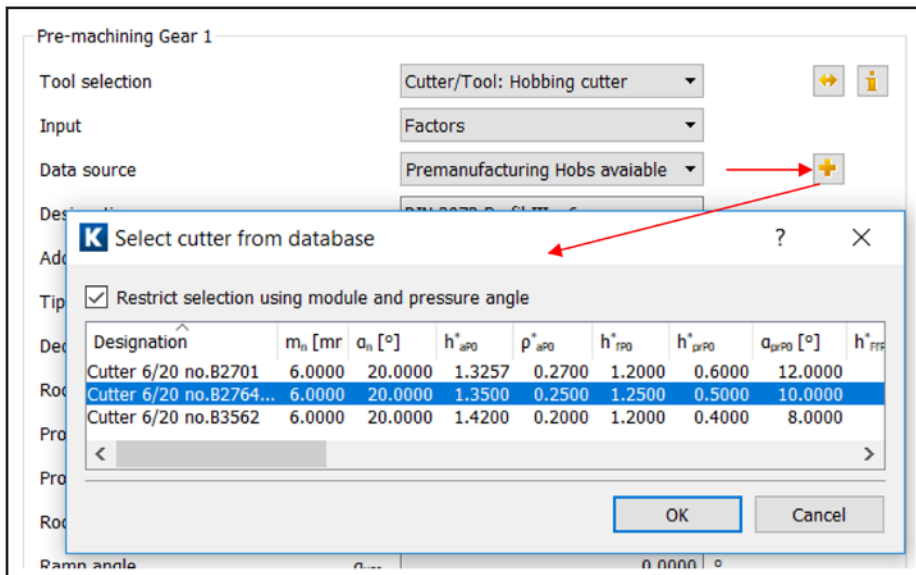

Figure 1 Selection of available cutters pre-filtered from module and pressure angle (symbols)

Setting:

List of cutters for reference profile Gear 1: Premanufacturing Hobs available

List of cutters for reference profile Gear 2: Premanufacturing Hobs available

Result list (extract):

Nr.	$m_n$ [mm]	$\alpha_n$ [°]	$\beta$ [°]	$z_1$	$z_2$	$h^*_{f1}$	$h^*_{f2}$	$p^*_{a1}$	$p^*_{a2}$	Tool Gear 1
1	6.000	20.000	0.000	25	76	1.350	1.350	0.250	0.250	16
2	6.000	20.000	0.000	25	76	1.350	1.350	0.250	0.250	16
3	6.000	20.000	0.000	25	76	1.350	1.326	0.250	0.270	16
4	6.000	20.000	0.000	25	76	1.350	1.326	0.250	0.270	16
5	6.000	20.000	0.000	25	76	1.350	1.420	0.250	0.200	16
6	6.000	20.000	0.000	25	76	1.350	1.420	0.250	0.200	16
7	6.000	20.000	0.000	25	76	1.326	1.350	0.270	0.250	17
8	6.000	20.000	0.000	25	76	1.326	1.350	0.270	0.250	17
9	6.000	20.000	0.000	25	76	1.326	1.326	0.270	0.270	17
10	6.000	20.000	0.000	25	76	1.326	1.326	0.270	0.270	17
11	6.000	20.000	0.000	25	76	1.326	1.420	0.270	0.200	17
12	6.000	20.000	0.000	25	76	1.326	1.420	0.270	0.200	17
13	6.000	20.000	0.000	25	76	1.420	1.350	0.200	0.250	18
14	6.000	20.000	0.000	25	76	1.420	1.350	0.200	0.250	18
15	6.000	20.000	0.000	25	76	1.420	1.326	0.200	0.270	18
16	6.000	20.000	0.000	25	76	1.420	1.326	0.200	0.270	18
17	6.000	20.000	0.000	25	76	1.420	1.420	0.200	0.200	18
18	6.000	20.000	0.000	25	76	1.420	1.420	0.200	0.200	18
19	6.500	20.000	0.000	23	70	1.322	1.322	0.200	0.200	19
20	6.500	20.000	0.000	23	70	1.322	1.322	0.200	0.200	19
21	6.500	20.000	0.000	23	70	1.322	1.322	0.200	0.200	19
22	7.000	20.000	0.000	21	64	1.318	1.318	0.200	0.200	20
23	7.000	20.000	0.000	21	64	1.318	1.318	0.200	0.200	20
24	7.000	20.000	0.000	21	64	1.318	1.318	0.200	0.200	20

Figure 2 Macro geometry variants using only available cutters.

This paper was first presented at the International VDI Conference on Gears 2019, 3rd International Conference on High Performance Plastic Gears 2019, 3rd International Conference on Gear Production 2019, Garching/Munich (VDI-Berichte 2355, 2019, VDI Verlag GmbH, Page 1533–1544)

erence profile) is defined. Such a task is simple to achieve if it is possible to add a list of available tools (Fig. 1) in the gear software.

A more advanced option is the integration of a list with available tools into a macro geometry variant generator. A tool called ‘Finesizing’ in *KISSsoft* (Ref. 2) permits, while keeping the main parameters such as center distance and face width fixed, for a given gear reduction, iterating over a range of normal modules, pressure and helix angles, with different combinations of number of teeth and profile shift coefficients. If the option ‘use only available tools’ is activated, only solutions using existing tools are displayed (Fig. 2).

**Use of available dresser/threaded grinding wheel combinations.** Another efficient manufacturing process is threaded wheel grinding which is used normally as a finishing process of gears. For dressing the grinding wheel, an expensive dresser is required. For a gear designer, when working on a new gear set likely with profile modifications, it would be helpful to get a list of existing grinding tools/dressers with the resulting profile modifications that will be produced when they are used for new gear geometry. With this information available, an existing dresser can possibly be reused for a new project. As displayed (Fig. 3), in the first step all available dresser/grinding wheel combinations are displayed with the amount ( $C_{ca}$ ) and length ( $L_{cda}$ ) of tip relief generated. After selecting the best fitting dresser, the tip relief amount can be further varied in the second step by the adaptation of the dresser wheel gap ( $A_{L^*eff}$ ).

### Checking if Economic Production Methods are Applicable

To design cost-competitive products, it is worthwhile to make production method decisions early. Many different methods such as grinding, shaping, honing, broaching, etc. can be considered and evaluated. In this paper, the relatively new manufacturing method—power skiving—is used to explain the integration of manufacturing restrictions into the design process.

**Power skiving.** The power skiving process is a breakthrough in the production of gears (Ref. 7). It is several times faster than gear shaping and much more flexible

than gear broaching. Power skiving is setting ever-higher standards in the *machining of internal gears and/or gears with critical interfering contours* (Fig. 4).

Originally intended as a competitive alternative to gear shaping, and in some cases to broaching, for small-to-medium-sized, non-hardened cylindrical gears, its range of application has expanded

significantly. Today, we find power skiving solutions for soft and hard finishing of internal and external gears, for machining shafts and worms, as well as for special profiles such as cycloidal gears for robot applications.

Most gear cutting applications are placed somewhere between distinct production worlds, i.e.: highly efficient mass

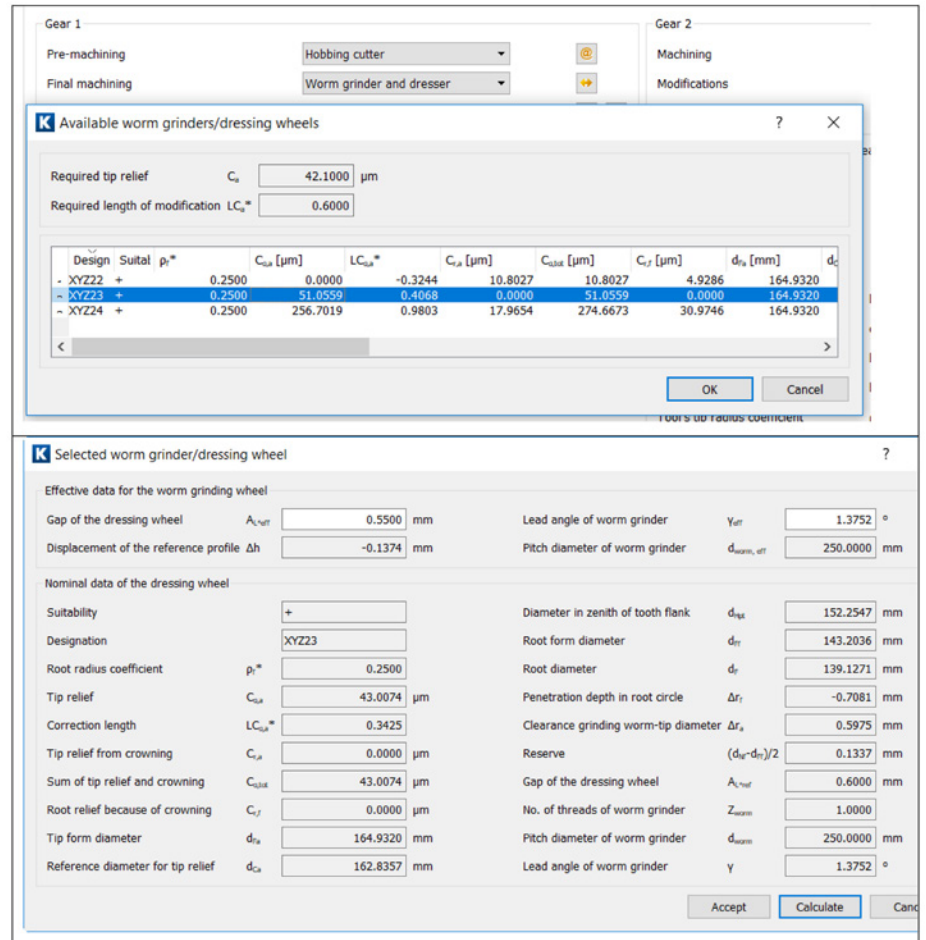

Figure 3 Selection of available dresser/threaded grinding wheel combinations. First step: selection of best fitting dresser; second step: due to a small change of the dresser wheel gap ( $A_{L^*eff}$ ), the requested tip relief amount ( $C_{ca}$ ) can be achieved.

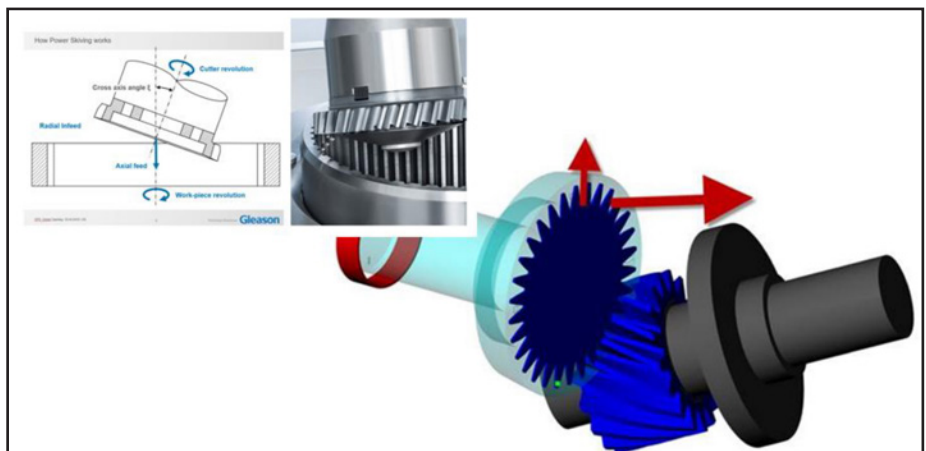

Figure 4 Left: power skiving process; Right: visualization in *KISSsoft* (Ref. 2).

production and flexible manufacturing of smaller, rapidly changing lots. Depending on the application, the power skiving process can be designed in such a way that it accommodates both requirements.

Demand for quieter gears and gear boxes and/or higher torque are increasingly determining requirements of the finishing methods for hardened gears. However, so far there has been no economical hard finishing solution for small to medium-sized internal gears on the market. Hard power skiving provides the potential for a particularly economical alternative to the traditional hard finishing processes.

The combination of extremely stiff latest-generation machines with direct drives in all relevant axes, integrated stock division, simulation software, process expertise and modern carbide tools have made hard power skiving a competitive production method for hardened gears. The quality and surface roughness which can be achieved are perfectly adequate for most

applications, and so a further finishing process step is usually not required.

Up until a few years ago, the boundaries of the skiving process were unknown. The process could only be optimized in advance to an unsatisfactory extent. In order to optimize the production output with respect to productivity and manufacturing costs, integrated solutions are becoming more important. These new, smart systems include gear design, process simulation, manufacturing and metrology equipment, workholdings, tools and support services such as re-sharpening and technology consulting.

**Verification of power skiving possibility.** Clearly, in gear design software, only basic manufacturing knowledge can be expected from a design engineer; therefore, only simple inputs can be imposed. This implies that not all data for a complete check of manufacturability is available. The check is therefore simplified and so there are cases where a reliable result cannot be achieved. The results of the

check can be in one of three categories: 1) power skiving is possible; 2) may be possible; 3) is not possible.

Whether power skiving is possible depends on different collision scenarios between the tool and gear (tool head, tool back or tool shaft) and on some geometric restrictions, e.g.—minimum length of involute on tool tooth, total overlap ratio, etc. The gear-tool setting is a classic crossed helical gear mesh, as defined by Niemann (Ref.3), but the theory must be extended to inner gear pairs. In many cases, a valid combination can be found just by adjusting the tool tooth number.

If such a check is available in a gear variant generator—showing macro geometry variants for a given gear stage—then it is easy for a gear designer to find a suitable variant which can be manufactured by power skiving (Fig. 6).

### Consideration of Known Manufacturing Deviations in the Gear Layout Process

**Manufacturing twist.** When grinding helical gears and applying lead modifications such as lead crowning an undesired side effect results — the manufacturing twist (Ref.4). It is therefore critical when designing the lead modifications to consider this usually unwanted side effect.

The root cause for the manufacturing twist is the contact line between the workpiece and the grinding wheel along the flank which is being ground. The contact line shape depends on the process, whether it is profile or threaded wheel grinding and the gear data itself. What both processes have in common is that the contact line for helical gears runs diagonally across the flank. However, the contact line in profile grinding is curved and oriented the other way around, compared to threaded wheel grinding where the contact line is straight but diagonal. Only on spur gears is the contact line straight and parallel to the top section of the gear—which is the reason why manufacturing twist does not appear on spur gears.

The effect of manufacturing twist is described as follows using the example of threaded wheel grinding. Figure 7 shows the diagonal line of contact on a simplified gear tooth. All points along this line, are generated at the same time. So, in case of grinding a symmetric lead crowning, the machine infed axis must follow a

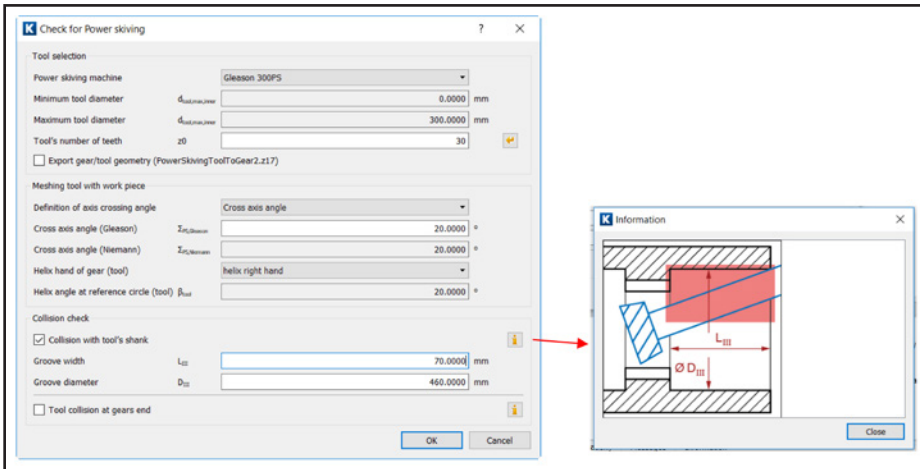

Figure 5 Requested data for the check, if power skiving is applicable.

Nr.	m <sub>n</sub> [mm]	α <sub>n</sub> [°]	β [°]	z <sub>1</sub>	z <sub>2</sub>	x <sub>1</sub>	d <sub>u1</sub> [mm]	ε <sub>α</sub>	ε <sub>β</sub>	ε <sub>γ</sub>	i	PSK <sub>1</sub>	PSK <sub>2</sub>
1	0.600	22.500	0.000	32	-50	0.800	29.341	0.975	0.000	0.975	-1.562	Yes	21
2	0.600	22.500	0.000	33	-51	0.800	29.941	0.980	0.000	0.980	-1.545	Yes	21
3	0.600	22.500	0.000	34	-52	0.800	30.541	0.984	0.000	0.984	-1.529	Yes	21
4	0.600	22.500	0.000	35	-53	0.800	31.141	0.988	0.000	0.988	-1.514	Yes	21
5	0.600	25.000	0.000	30	-47	0.146	27.169	1.459	0.000	1.459	-1.567	Yes	21
6	0.600	25.000	0.000	31	-48	0.133	27.754	1.464	0.000	1.464	-1.548	Yes	21
7	0.600	25.000	0.000	32	-49	0.120	28.339	1.469	0.000	1.469	-1.531	Yes	21
8	0.600	25.000	0.000	33	-50	0.108	28.924	1.473	0.000	1.473	-1.515	Yes	29
9	0.600	27.500	0.000	30	-47	-0.005	26.988	1.408	0.000	1.408	-1.567	No	0
10	0.600	27.500	0.000	30	-47	0.095	27.108	1.378	0.000	1.378	-1.567	No	0
11	0.600	27.500	0.000	31	-48	-0.017	27.573	1.411	0.000	1.411	-1.548	No	0
12	0.600	27.500	0.000	31	-48	0.083	27.693	1.382	0.000	1.382	-1.548	No	0
13	0.600	27.500	0.000	32	-49	-0.030	28.158	1.414	0.000	1.414	-1.531	No	0
14	0.600	27.500	0.000	32	-49	0.070	28.278	1.386	0.000	1.386	-1.531	No	0
15	0.600	27.500	0.000	33	-50	-0.043	28.743	1.416	0.000	1.416	-1.515	No	0
16	0.600	27.500	0.000	33	-50	0.057	28.863	1.389	0.000	1.389	-1.515	No	0
17	0.600	30.000	0.000	30	-47	-0.147	26.817	1.358	0.000	1.358	-1.567	Yes	27
18	0.600	30.000	0.000	30	-47	-0.047	26.937	1.334	0.000	1.334	-1.567	Yes	27
19	0.600	30.000	0.000	30	-47	0.053	27.057	1.312	0.000	1.312	-1.567	Yes	27
20	0.600	30.000	0.000	31	-48	-0.159	27.402	1.360	0.000	1.360	-1.548	Yes	27
21	0.600	30.000	0.000	31	-48	-0.059	27.522	1.337	0.000	1.337	-1.548	Yes	27
22	0.600	30.000	0.000	31	-48	0.041	27.642	1.315	0.000	1.315	-1.548	Yes	27
23	0.600	30.000	0.000	32	-49	-0.170	27.989	1.361	0.000	1.361	-1.531	Yes	27
24	0.600	30.000	0.000	32	-49	-0.070	28.109	1.339	0.000	1.339	-1.531	Yes	27
25	0.600	30.000	0.000	32	-49	0.030	28.229	1.317	0.000	1.317	-1.531	Yes	27
26	0.600	30.000	0.000	33	-50	-0.182	28.575	1.362	0.000	1.362	-1.515	Yes	27

Figure 6 Macro geometry variants with check, if power skiving is applicable.

parabolic function  $x(z)$  and will result in a change of radial feed over the face width “ $b$ ” of the gear. Usually the highpoint of a crowning is set to the middle of the tooth face width represented by the blue point in Figure 7. Since all points along the line of contact are ground (generated) at the same time, this results in the root area, represented by the red point, achieving its crowning highpoint shifted towards the top of the gear. The tip area, which is represented by the green point, achieves its highpoint displaced towards the bottom of the gear. Thus, the lead crowning is only symmetrical in the middle of the gear. When measuring the lead line in the root (red line) and tip area (green line), the crowning also shows a lead angle error while simultaneously affecting the profile modification. The middle section has no profile error but a slight crowning being affected by the lead crowning. The top and bottom profile lines show a clear profile angle error.

Figure 8 shows a grinding result where this effect can be seen. The amount of twist error, which is defined as the absolute change in profile angle error from top to the bottom, is for this example about  $25 \mu\text{m}$  and much more than the allowed tolerance.

**Considering manufacturing twist at design stage.** Today, it is possible with very modern grinding machines to compensate for this undesired effect (Ref.5). But if such a machine is not available, manufacturing twist should be considered, when a loaded tooth contact analysis is executed during the gear design process. Hellmann (Ref.6) proposed an accurate formula to get the amount of twist when a crowning in generation grinding is produced.

$$C = 8 * C_{\beta} * \tan(\beta_b) * L_{\alpha} / b \quad (1)$$

(Symbols according to ISO21771 (Ref.1).  $C$ : Twist;  $C_{\beta}$ : Crowning amount;  $\beta_b$ : Base helix angle;  $L_{\alpha}$ : Involute length;  $b$ : Face width.)

Based on this formula, the generated manufacturing twist can be determined by the gear design software (Fig.9). The twist is automatically calculated and considered in the contact analysis and the 3D display. The design engineer is therefore able to decide if the unwanted twist is acceptable or if additional profile and/or flank line modifications are necessary to compensate for this error.

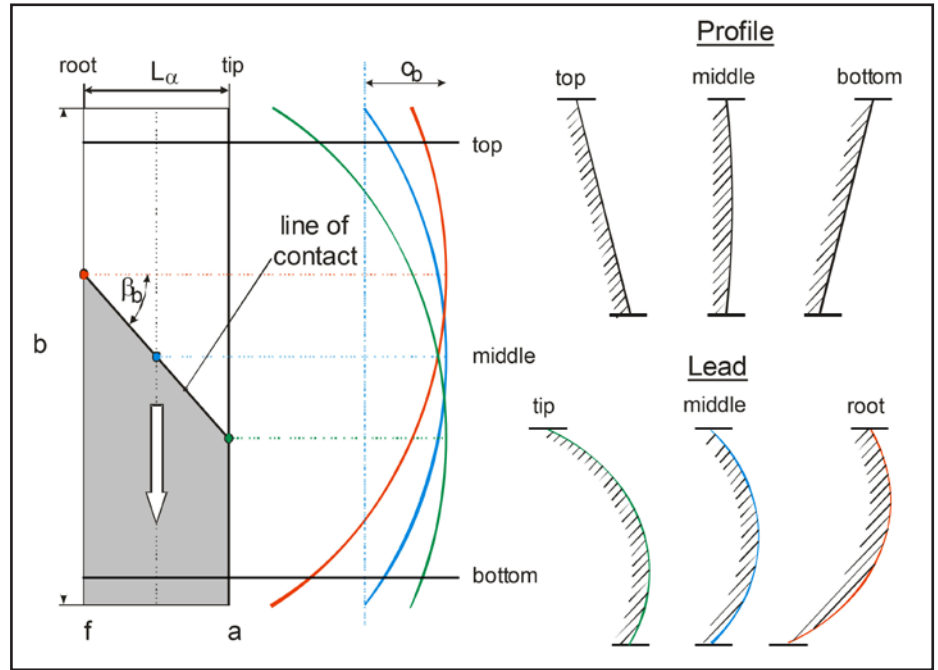

Figure 7 Contact line and twist generation in threaded wheel grinding.

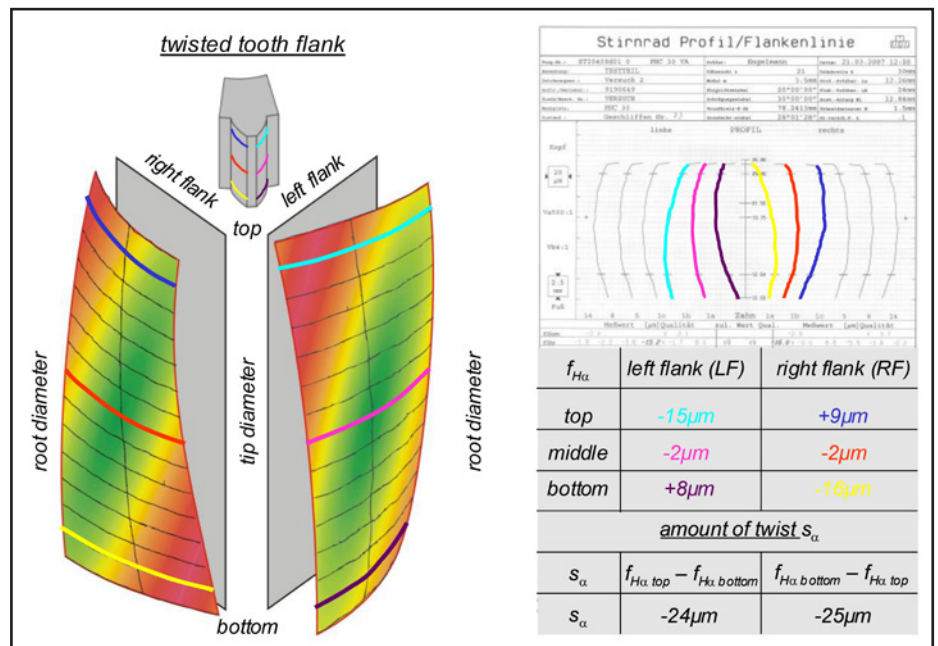
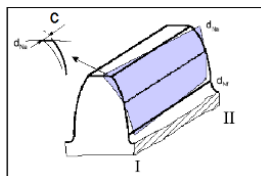

Figure 8 Twisted tooth flank.



### Conclusion

The integration of manufacturing information into gear design software reduces cost during the design process by avoiding time-consuming back and forth between the design and manufacturing departments. The challenging task for such software is ensuring the design engineer does not need specific manufacturing expertise. Otherwise he or she would be overwhelmed and not use such a feature. **PTE**

### References

1. ISO21771. 2007, Gears — Cylindrical involute gears and gear pairs:concepts and geometry.
2. KISSsoft gear calculation software, 2019, [www.KISSsoft.com](http://www.KISSsoft.com).
3. Niemann, G. and H. Winter. 1983, *Machine Elements Design and Calculation in Mechanical Engineering: Vol 3: Gears*, ISBN 0-387-10317-1, Springer publisher, Berlin.
4. Türich, A. "Producing Profile and Lead Modifications in Threaded Wheel and Profile Grinding" *Gear Technology Magazine*, Jan/ Feb 2010.
5. Türich, A. Schränkungskontrolliertes Schleifen — Von der Theorie zur Praxis, Seminar Feinbearbeitung von Zahnradern, WZL RWTH Aachen, November 2011.
6. Hellmann, M. Berücksichtigung von Fertigungsabweichungen in der Auslegung von Zahnflankenmodifikationen für Stirnradverzahnungen, WZL RWTH Aachen, November 2015.
7. Stolz, U. Power Skiving – die Grenzen Vrschieben Sich, WB Werkstatt+Betrieb, 5/2018.

Gear	Flank	Type of modification	Value [µm]	Factor 1	Factor 2	Status	Information
Gear 1	both	Tip relief, linear	16.0000	0.7376		active	dCa=661.966mm, ξ=25.147°
Gear 1	both	Crowning	26.0000			active	rcrown=155769mm
Gear 1	both	Twist due to manufacturing (generation grinding)	26.0000			active	C(R) = -19.3 C(L) = -19.3 µm
Gear 2	both	Tip relief, linear	16.0000	0.7376		active	dCa=158.956mm, ξ=33.334°

Figure 9 Gear with helix angle 23° and face width 180 mm; manufacturing twist is 19.3 µm for a crowing of 26 µm.

#### Dr. Ulrich Kissling

studied machine engineering (1976-1980) at the Swiss Technical University (ETH), where he also completed his doctoral thesis — "Pneumatic Weft Insertion on Weaving Machines. In 1981 he started his professional career as calculation engineer for a gearbox manufacturing company in Zurich, progressing there to technical manager and ultimately managing director. As a calculation engineer for gearbox design, he began developing software for gear, bearing and shaft layout. In 1985 he branded this software 'KISSsoft' and started to market it, selling its first license in 1986. In 1998 he founded his own company — KISSsoft AG — concentrating on software development and growing staff from three people in 1998 to workers in 2017. Today, aided by the contributions of partner and managing director Dr. Stefan Beermann, KISSsoft is the leading drivetrain design software, used by more than 3,000 companies on all continents. An internationally respected gear expert, Dr. Kissling is chairman of the TK25 committee (gears) of the Swiss Standards Association (SNV) and a voting member for Switzerland in the ISO TC 60 committee. He actively participates in different work groups of ISO for the development of international standards.



#### Udo Stolz

studied (1980 – 1985) mechanical engineering at Transylvania University in Brasov, Romania – graduation as Dipl. Ing. From 1993 – 1994, he enrolled in marketing studies for engineers at Free University of Berlin, Germany, graduating as master of business marketing. Since 1987 he has held several positions in the technical and sales departments at Hermann Pfauter GmbH, Gleason-Pfauter GmbH and Gleason Corporation. Stolz since 2009 has served as vice president, Worldwide Sales & Marketing, for Gleason Corporation.



#### Dr. -Ing. Antoine Türich

studied mechanical engineering (1990-1996) at the University of Hannover, and from 1996-2001 he was a research assistant at the Institute of Production Engineering and Machine Tools, University of Hannover, Germany. He earned his Ph.D. in 2005 at the University of Hannover: Werkzeug-Profilherstellung für das Verzahnungsschleifen. Türich has been with Gleason Corporation (Hurth, Munich) since 2002, serving in roles including manager of technology development and, currently, as director of product management—hard finishing solutions.



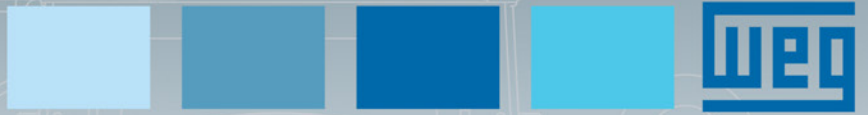

# THE **SUPERIOR** CHOICE

WEG's proven reliability in a Rolled Steel frame



- Rated Output: .25 to 25 HP
- 3600, 1800, 1200, 900 rpm
- 48-256T frame
- Foot mount, C-Face or footless available
- AEGIS® SGR Inside (up to 20 HP in stock)
- Brake Motors now available

- Robust base and eyebolts
- Superior Cooling System
- Dual Rated 50/60 HZ
- Class F Insulation
- Aluminum Enshields



**Wide Range of Configurations in stock.**

# Transverse Magnet Flux AKA Hybrid Step Motor Driver Techniques

Donald Labriola P.E. QuickSilver Controls

The transverse flux permanent magnet motor – also known as a hybrid step motor or hybrid servo motor – has a wide range of performances, depending upon how you drive these motors, and whether you operate them in open loop or one of the many variants of closed loop methods you use. In this third installment we will cover some of the many ways to drive these motors, as well as how these choices affect the performance of these motors.

The early years of transverse flux motors saw these motors driven from a sinusoidal line voltage, often using a capacitor to phase shift the current into the second phase to set the direction of motion. Voltage drive from a constant voltage produces an almost constant speed of operation. These motors are just a high-pole-count synchronous motor. The high-pole-count feature reduces the output speed while also increasing the available torque for a given package size. The use of high-pole-count motors can eliminate the gearhead—or at least a stage or two in high-inertia applications, thus simplifying the mechanical design.

Replacing the AC line voltage driving the coils, with switches that control the phase and frequency of the current through the stator windings, transformed the use of these motors from a synchronous motor to a step motor. The earliest step patents show relays being used to control the flow of current through the windings. These were later replaced with

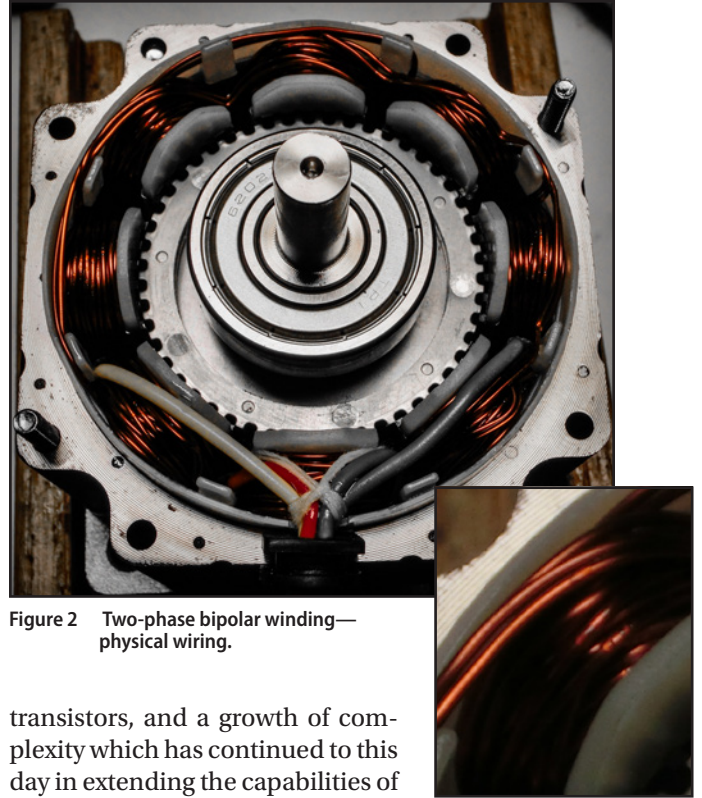

Figure 2 Two-phase bipolar winding—physical wiring.

transistors, and a growth of complexity which has continued to this day in extending the capabilities of these motors.

## Motor Construction

Let us first look at the physical wiring of these motors and then how they are typically represented in schematics. The common 2-phase, 1.8-degree stepper normally has 8 pole pieces with 5 or 6 teeth each. A gap between the pole pieces provides space for wire to pass while winding the motor; the two windings function similarly. I will label the top pole piece in this view as A. Going clockwise, then other poles are B, A\*, B\*, A, B, A\*, and B\* (Fig. 1). The winding sense for A windings is opposite the sense for A\* windings; likewise for the B and B\* windings. For this position of the rotor, with respect to the stator, the teeth of the stator poles at “A” locations have maximum alignment with the upper rotor teeth, while the teeth of the stator at “A\*” locations have minimum alignment with the upper rotor teeth and maximum alignment with the lower rotor teeth. A similar tooth alignment for “B” and “B\*” stator “claws” is seen if the rotor is rotated by one full step or 1.8 degrees mechanical. Thus, if A is energized such that A claws are attracted to the teeth of top pole cap, the A\* claws are simultaneously attracted to the teeth in the lower pole cap.

Although the actual design has 8 stator windings interconnected as two phases, the typical schematic shows the two winding (sets) at 90 (electrical) degrees from each other. The

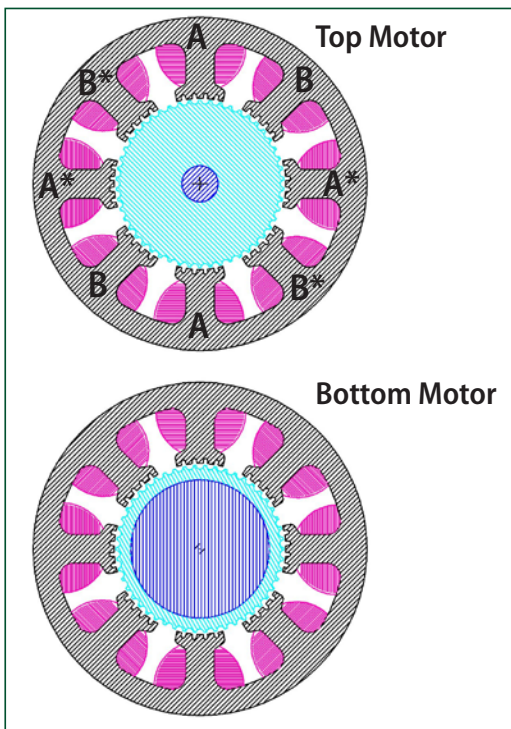

Figure 1 Motor windings, rotor teeth.



stators are typically wound with two smaller gauge wires wound simultaneously around each pole piece (claw), as the thinner wires are easier to handle, and they pack in better to give a higher copper fill (Fig. 2). The magnified view (Fig. 2 insert) shows the bifilar = two wire construction.

Some motors bring out all 8 connections (Fig. 3) to allow the user to wire them as they please. Other motors are sold with these internal coils either internally connected in parallel to provide a higher current winding, or in series for a lower current winding. A unipolar motor will commonly wire the coils of each phase in series and bring out the center tap, resulting in a 6-wire unipolar configuration. We will look at each of these and their various drive circuits.

### Unipolar Drivers

There are a couple of major divisions in the driving of these motors: Unipolar and bipolar. With unipolar, the (intentional) driven signal through a given winding only flows in one direction. Two separate windings over the same magnetic structure are used, with the connection for the second winding reversed to allow reversing the magnetic flux polarity between using the first coil half and the second coil half. Bipolar drives have one “logical” winding-per-pole-piece. I say logical as most commercial step motors use a bifilar winding, i.e. — two wires wound side-by-side around the stator pole. The smaller-diameter wire is easier to wind, and the resulting motor can be used either for unipolar or bipolar operations, according to how the windings are interconnected. The two bifilar windings on each of the two phases results in a number of wiring configurations: 4-wire, which is a bipolar configuration; 6-wire, which supports unipolar drivers (although bipolar drivers can use 4 of the 6 connections and ignore the others); and 8-wire configurations, which allow the user to choose how the windings are interconnected.

The 6-wire unipolar design (Fig. 4) runs the motor from a supply voltage that is equal to the motor winding voltage rating. The current is automatically limited by the winding resistance of the motor. Energizing Q1 causes current to flow from V+ through the center tap to A and to ground. We will consider that this causes the shown north-south alignment of the rotor magnets. Alternatively, energizing Q2 (with Q1 off) reverses the direction of the magnetic field, causing the rotor to want to move to 180 (electrical) degrees from the orientation shown. D1 provides a path for the current flowing through the motor inductance to continue flowing when Q1 is turned off, limiting the inductive “kick” to protect the transistor. This circuit will work, but the motor speed will be severely limited. First, the current will only slowly decay when the transistor is turned off, as the voltage across the inductor will only be one diode drop. The rate of change of current though the winding is the voltage across the inductance divided by the inductance; the higher-voltage motors tend to have a large inductance. Second, the energizing Q1 will pull node “A” low, which will try to pull A\* higher than V+, resulting in current flow through D2, which momentarily reduces the torque-producing magnetic flux.

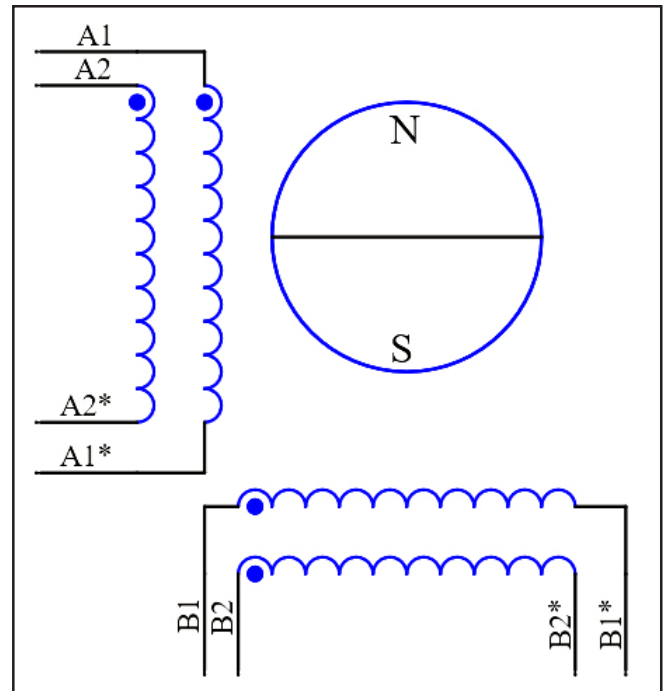

Figure 3 Eight-wire configuration.

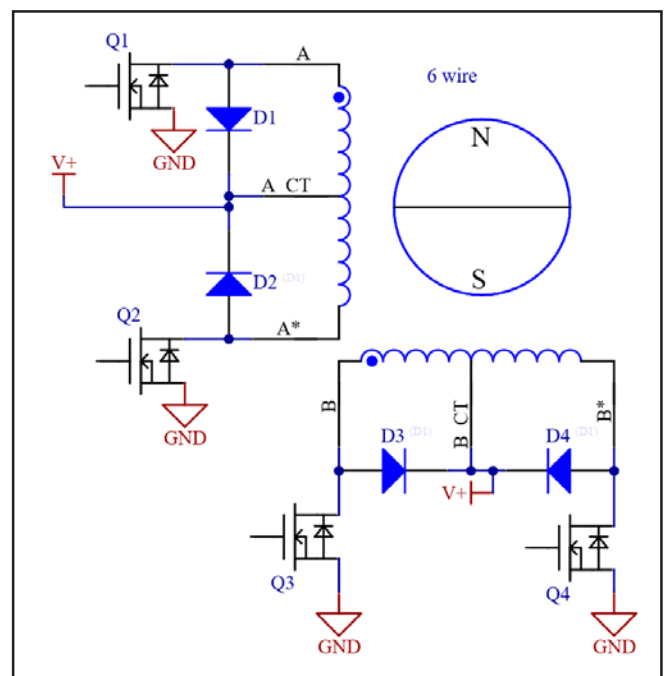

Figure 4 Six-wire unipolar.

Adding Zener diodes D5 and D6 (Fig. 5) — with a voltage rating greater than  $V_+$  — prevents the voltage induced at  $A^*$  when A is energized from being high enough to overcome D2 and D5; thus the flux is not reduced at turn on. The current through the energized coil is also now able to decay quickly at turn-off, as the voltage generated by the field decay sees a higher voltage, i.e. — the D1 and D5 in the case of phase A.

This improvement can increase the speed capabilities of the motor by about a factor of 3 for the same motor and supply. The current rise is still limited by the relatively low  $V_+$  rating and comparatively large inductance of high-voltage, low-current

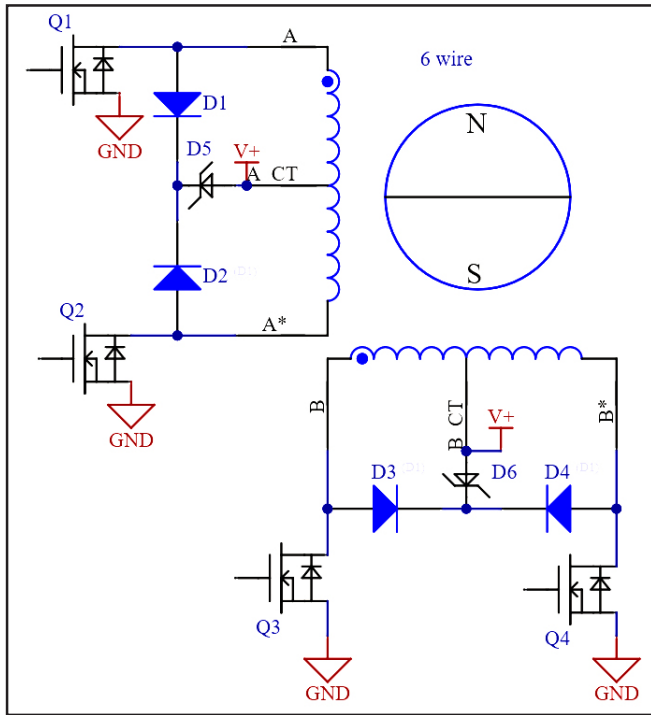

Figure 5 Faster decay unipolar.

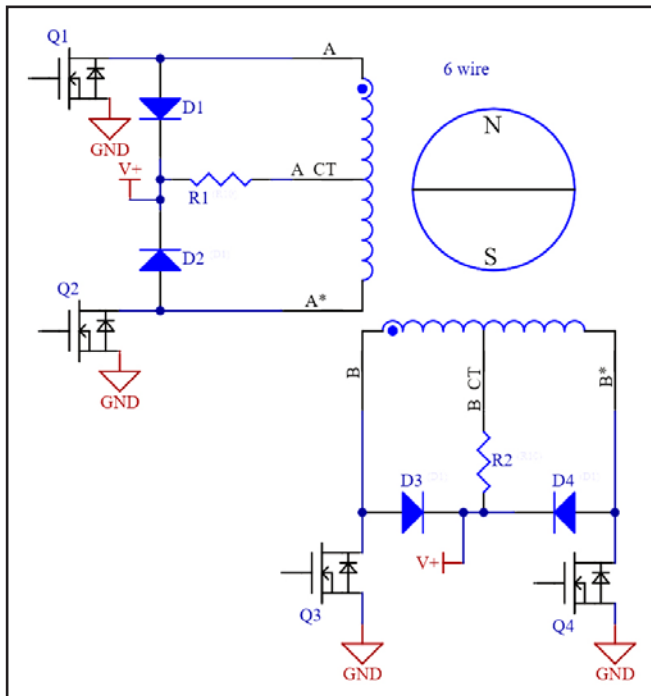

Figure 6 L/10R unipolar drive.

motors. The time constant of the current for this configuration is  $t=L/R$ . The current must be kept low to prevent overheating of these motors, as the resistive loss of each winding is  $V_+$  times the current rating of the winding at that voltage.

What is needed is a way to speed up the rise in current (and the fall in current) and to also allow the current to rise in the presence of a higher back-EMF present when the motor is spun faster.

This was accomplished (Fig. 6) by adding an external resistor in series with the center tap voltage. If the external resistance was 9 times the half-winding (A to A\_CT) resistance, the result is a 10-fold increase in current rise and fall times. Any back-EMF now faces a significantly higher power supply voltage, allowing the motor to supply significantly more mechanical power at higher speeds. This can be done using either a lower-voltage motor winding, a higher supply voltage — or a combination of both; this was a common solution to many early CNC implementations. The resistors generate a significant amount of unwanted heat, but rapid motion at high torques is easily accommodated.

### Bi-Level Unipolar Drivers

The next step along this full- and half-step methodology was to allow the resistor to be replaced by a switched high-voltage supply (Fig. 7); this is called *bi-level*. The high voltage is switched on just long enough for the current to reach the steady state current, and then the voltage is dropped down to the steady state voltage. For a 5v step motor rating, 50v may be applied for so many microseconds after a phase is turned on, and then the center tap voltage is dropped down to 5v. The catch diodes go to the higher voltage supply to allow for more rapid current decay when the phase is turned off.

For phase A, Q5 switches the  $V_{++}$  supply on to the center tap of A. Once a time has elapsed or (preferred) the current is sensed at the motor current rating, Q5 turns off and Q6 turns on, thus providing a supply path for the current to be sustained.

The unipolar drive can also be chopped to sustain current, but the rapid current decay can cause large ripple currents and increases losses (heating) in the motor. Most of the efforts with PWM drives have thus been developed with bipolar

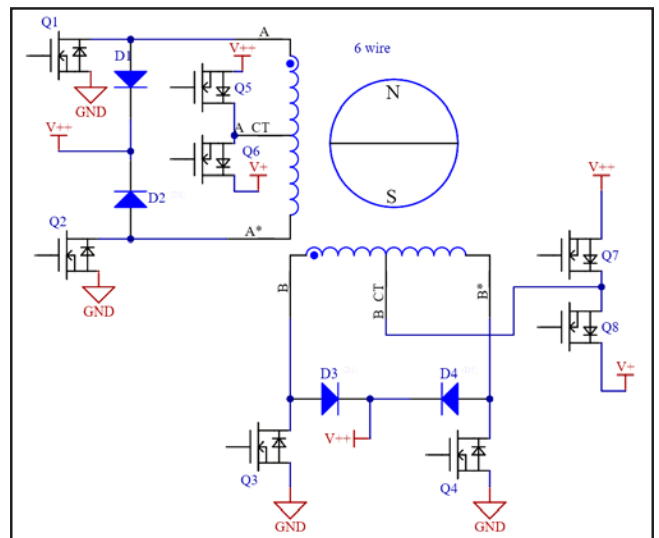

Figure 7 Bi-level unipolar drive.

motors, which will be detailed below.

Note that the unipolar drive does not need to operate fully switched; it alternately can be operated in analog fashion, where the winding current is monitored and the transistor (bipolar or MOSFET) modulated to produce the wanted current. US4121145 teaches a unipolar motor operating in microstepping mode where the net current for phase A is made to follow a sine wave, while that for phase B is made to follow a cosine. A lookup table feeding a DAC provides the sine and cosine voltage references to either an analog current controller or in other designs to a chopping drive to generate the wanted sine and cosine winding currents. Command step and direction pulses walk through the sine-cosine table. US4091316 takes this further using a tachometer on the shaft to add a damping term into the commanded current to implement damping in the system.

### Bipolar Drives

Bipolar drives require twice as many active power devices as the simple unipolar techniques. The two windings in the bifilar windings are commonly wired in parallel to reduce the back-EMF and the inductance. This results in one-half the winding resistance versus the unipolar configuration. With resistive power losses  $P=I^2R$ , for the same current the heating is one-half, or if the heating is maintained at the same level, the current can be increased by the square-root of two, which is a current increase of 41% with a similar torque improvement (if the motor magnetics are not saturating). This is a significant torque improvement now that active power devices have mostly been integrated and their cost has greatly reduced from the early days. Again, the schematics in this section are greatly simplified and do not show the transistor drive circuitry; bipolar transistors can be used instead of MOSFETS.

The same bipolar schematic (Fig. 8) can be used both in a full-step L/R configuration, as an L/10R by adding a resistor in series with each motor winding, or as a chopper drive if a current sensor is added to sense each winding current (Fig. 9).

The simple L/R bipolar driver keeps Q1 and Q4 in the same state, and opposite to Q2 and Q3. That is, the winding is either energized A to A\*, or alternatively A\* to A; phase B functions similarly. This drive operates similarly to the faster-decay unipolar drive in capability—except that the motor current can be 41% higher with the same motor heating—so the motor puts out more torque. The motor is also able to dynamically brake easily as the energy from the motor is easily regenerated back into the power supplies without the losses of the Zener diode. Again, the L/10R operation may be implemented by reducing the motor winding voltage (which normally raises the current rating) and or raising the power supply voltage by a factor of 10 (or a combination of the two) and adding a resistor in series with the winding, which has a resistance of 9 times the motor winding resistance.

With the addition of a current sensor (Fig. 9) and current control logic, this drive configuration may also be used for the popular bipolar chopper drive configuration. The current sensor is most commonly a resistor between the source of the lower side transistors (Q2, Q4 for phase A) and ground. The current sense resistor, or a hall current sensor, may also

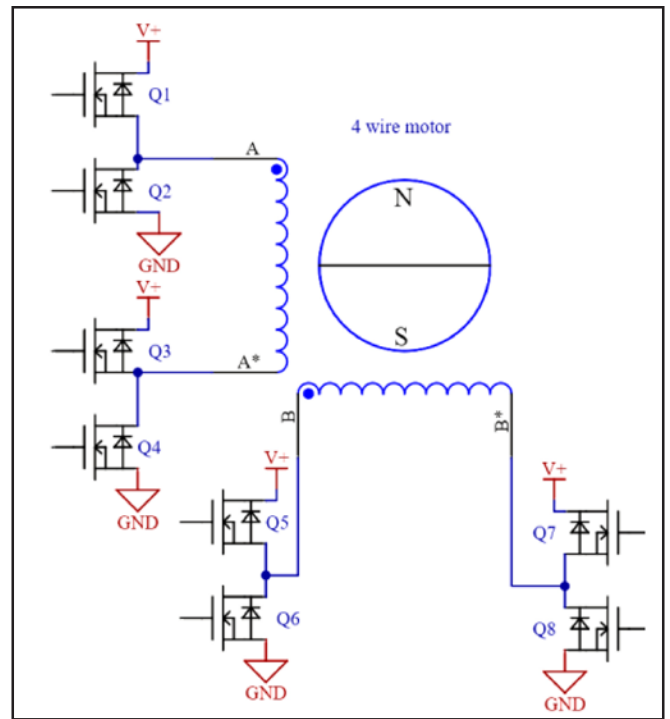

Figure 8 Bipolar driver.

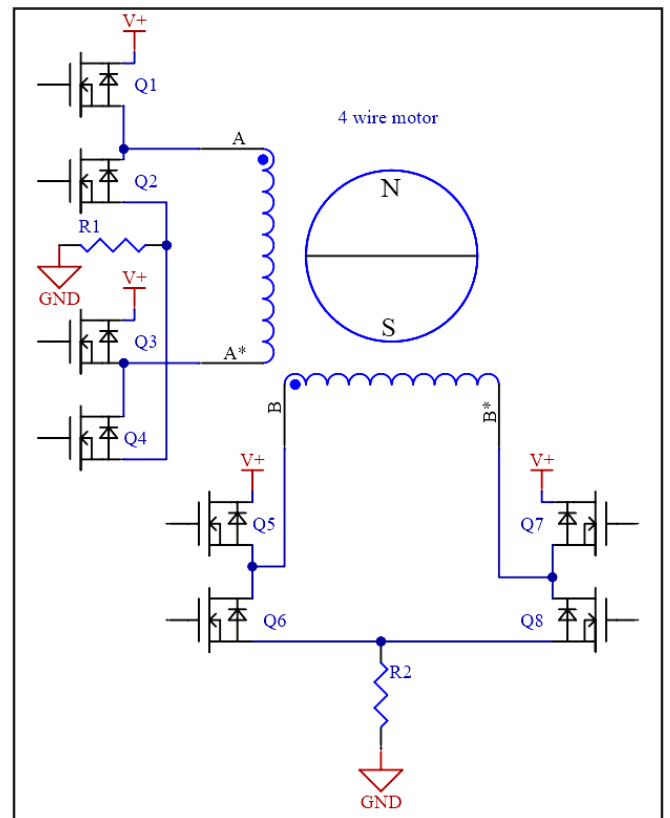

Figure 9 Bipolar drive with current sense.

For Related Articles Search

step motors

at [www.powertransmission.com](http://www.powertransmission.com)

directly measure the current through the windings. While either only Q2 or Q4 is on at one time (while both on bypasses the current sense resistor), the current can be measured with direction of current flow corrected by knowing which side of the lower bridge transistors is turned on at the measurement time.

The bridge may be driven as a positive drive voltage (Q1, Q4 on), a negative drive voltage (Q2, Q3 on), or recirculate (either Q2, Q3 on or Q2, Q4 on). The bridge may also be operated in a rapid decay mode by only having either Q2 or Q4 turned on, with the catch diode (or body diode) of Q3 or Q1 providing a path for current to flow back to the power rail. Recirculate mode keeps the winding shorted by two transistors, keeping the voltage across the winding low, which keeps the current from decaying quickly. The rapid delay mode causes the full power supply voltage to be across the winding in a direction that opposes the current flow until the current flow has decayed to zero (at which point the catch or body diode stops conducting). This is useful both to capture regenerated power from the motor and to rapidly drop the current when preparing to reverse the phase of the current through the winding.

### Basic Hysteretic Current Control

When the motor is operating from a voltage greater than the continuous motor voltage rating (motor resistance \* continuous motor current), that is not just an L/R configuration; the bridge must switch or chop to keep the current controlled within the motor ratings. This is commonly accomplished using a small sense resistor at the bottom of the bridge (US5952856). The current control is typically peak sensing with a fixed frequency. The input to the driver may be just the phase, or a phase and a current level. The current level may have either a few levels (half-step, quarter-step) or many levels (commonly 256) for microstepping. With hysteretic control, either Q1 and Q3 are switched on (for a positive current), or Q3 and Q2 are switched on (for a negative current) and the voltage across R1 rises to the desired threshold for the commanded current. The phase then goes into regenerate mode where Q2 and Q4 are turned on (alternately Q1 and Q3 for some drivers). The winding is effectively shorted with the only voltage drop being the losses in the winding resistance and the transistors; this causes the current to slowly ramp down. When the next chopper period is started by the clock, the two alternate transistors are again switched on, allowing the driver to sense the current and the resistor voltage is again monitored.

### Fast Decay Mode

A later addition allows the regeneration cycle to be replaced by a rapid decay cycle, as determined by either the driver or the attached processor. After the upper current threshold has been reached, the opposite low-phase is energized (Q4 turned on and Q2 turned off if it was a positive current cycle) and both upper transistors (Q1 and Q3) are turned off. The winding sees the full power supply voltage in a direction that causes the current to rapidly fall, which continues until the next cycle of the chopper clock. Some drivers implement a

lower threshold on the current, which allows the device to go into recirculating mode once the threshold has been reached by turning on both lower transistors (Q2, Q4) to slow the current decay rate.

### Minimum Current Problem

The current sensing PWM modulation has a problem near-zero current. The current comparator normally has a lock-out period on the comparator so that it does not trigger the turn on noise of the transistor (gate current spike and reverse recovery period of the body diodes). The drivers also commonly have a minimum on time to allow the transistors to completely turn on. The sum of these two time periods adds up to set a minimum on time. A 1 uS minimum on time with a 40 uS chopping period (25 kHz chopping frequency) is a 2.5% minimum on time. If the motor is being operated from a drive voltage that is substantially above its continuous operating voltage (for example a 3.3v motor with a 48v power supply), the minimum on time can be a substantial fraction of the full-rated current ( $48v/3.3v * 1us/40us = 36\%$ ). For full-step operation, or even half-step, this is not an issue; but for high-resolution microstepping, the minimum on time can introduce a significant distortion around the zero current point, making for a jump in rotor position as the current of each phase passes through zero commanded.

### Subharmonic Oscillation

The hysteretic current controller tends to have a mode where the motor chopping is audible, even though it is being chopped at 25kHz. When just holding a current, if the current starts out a bit lower than average, then the turn on time is longer to get the winding up to current; the recirculation time is thus reduced. The following cycle the current has not decayed down as far as the previous cycle, causing a shorter turn on time to reach the current threshold. This leaves a longer recirculation time, causing the current to decay to a lower level. The cycle now repeats. This causes a current variation at one-half the chopping frequency. The 12.5 kHz can make a high-frequency squeal. The circuit may also find a similar instability at one-third the chopping frequency, now moving the acoustical noise to 8.33 kHz — well within the hearing range. It is quite common to hear the stepper motor drivers “singing.” This is *not* a desirable sound!

### Mid-Frequency “Resonance”

The mid-frequency resonance operates almost like the subharmonic oscillation, but comes from a different mode of operation. With a current-controlled driver, as the motor reaches a critical speed, the back-EMF of the motor combined with the commanded step rate causes the current drive to not quite reach the desired current. This slight reduction in current reduces the motor torque, causing the motor to slightly slow, which then reduces the back-EMF. The chopper drive is then able to bring the current up to the commanded level, causing the motor to speed up again; this cycle then repeats. The motor operating at this speed sees an unstable speed of operation, causing rough motion. It is usually called a “resonance” in the literature, but it is really a limit oscillation, as

the driver switches back and forth from current control to just a voltage drive. The resulting unstable shift in the phase of the current applied to the motor varies between these two modes of operation, and gives rise to the instability at this critical speed.

### Second- and Fourth-Quadrant Operation

When the motor is operating in braking mode, i.e. — positive torque with negative speed or negative torque with positive speed — the motor is acting as a generator. The back-EMF causes the current to rise when the windings are shorted. The basic hysteretic control has difficulty accurately regulating the current, and the ability to precisely control the motor suffers. There are a couple of techniques to tame regeneration, as well as the zero-current control problem.

### Anti-Phase

Anti-Phase (Fig. 10) constantly switches modes between the opposite pairs of transistors; either Q1 and Q4 are on, or Q2 and Q3 are on. A zero-average voltage is obtained by operating the bridge at 50%, or half the time full-voltage positive, half the time full-negative. The advantage of this is that the applied voltage is smoothly variable, from full-positive through full-negative voltage, allowing the current to be well controlled through zero. As exactly one low-side transistor is always on, the current may be continuously monitored and the duty cycle can be adjusted to control the current, whether the winding is accepting power or generating power. The anti-phase current controller typically has tuning with damping capabilities that help eliminate the subharmonic oscillations.

Not surprisingly, the anti-phase phase drive is more complex to sense and control the driver. It unfortunately also maximizes the ripple current in the motor, which generates unwanted heat. It also applies a higher RMS voltage to the winding than the other methods. The core losses are a function of RMS voltage and frequency, so again this contributes to higher motor temperatures — even if the motor torque is low. The measured temperature rise in a motor with zero-average current was measured to be on the order of 20C from this combination of effects.

### Gated Anti-Phase

The advantages of anti-phase for controlling current and for good control through zero-current can be combined by using a method known as gated anti-phase (Fig. 11). This method is used by QuickSilver Controls and is described in Patent US59778737. The voltage to be applied to the motor for the following cycle is determined from a model of the motor. The duty-cycle necessary to cause the anti-phase signal to generate this voltage is determined. A gate is then applied to the drive signal, adding at least the minimum turn on time before the directional reversal signal at the start of the cycle, and enough after the transition to result in the desired voltage to the driver. Note that as the motor is being accurately modeled (using position feedback), the need to physically measure the motor current is eliminated, simplifying the hardware.

Gated anti-phase provides good current control through zero-current, it provides good 4 quadrant control, and it

minimizes the applied RMS voltage to the motor, significantly reducing motor heating. The sub-harmonic oscillations are also eliminated, making for a noticeably quiet drive. As this drive is always actually operating in voltage mode, there is no mid-frequency resonance.

The next installment of this series of articles will cover feedback methods and various closed loop control options. **PTE**

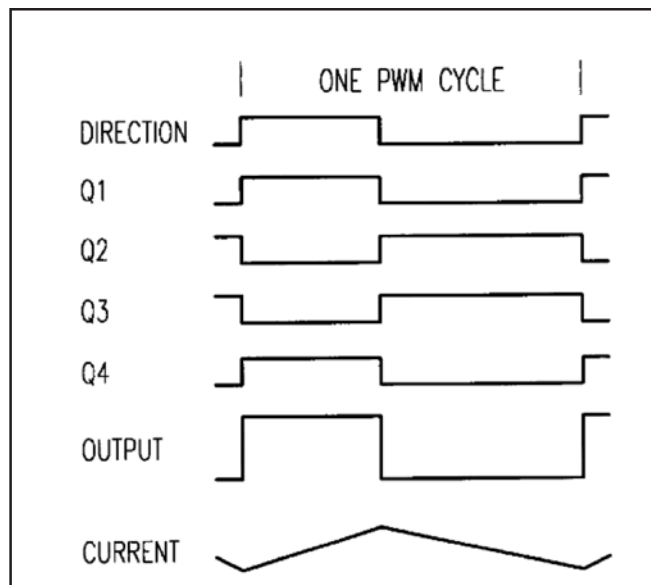

Figure 10 Anti-Phase

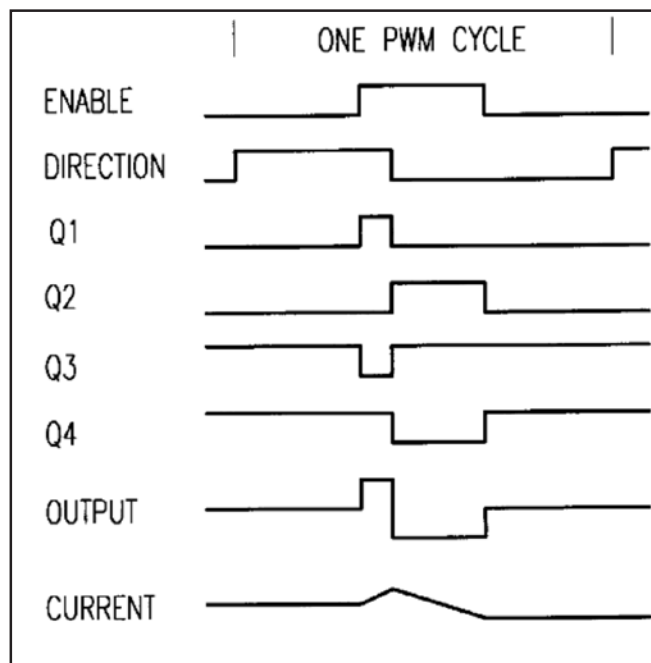

Figure 11 Gated anti-phase.

**Donald P. Labriola II**, president and founder of QuickSilver Controls, Inc., specializes in servo controllers and motors, with a special focus on cost-effective motion control. He has been granted eleven US patents as well as numerous international patents. His background includes over 40 years of motion control including 20 years in medical instrument design. He enjoys gardening, camping and Ham radio — and motion control!



## Voith

### COMPLETES ACQUISITION OF ELIN MOTOREN GMBH

After receiving all the official approvals, Voith successfully completed the acquisition of ELIN Motoren GmbH on April 30, 2020. ELIN Motoren, headquartered in Austria, is a high-tech company in the field of electric motors and generators that is active worldwide and supplies individualized solutions for industrial applications. “The acquisition of ELIN Motoren is an important strategic step for Voith,” states Dr. Uwe Knotzer, president and CEO of



Voith Turbo. “The portfolio of the company is an outstanding addition to our industrial drive solutions and supports our position as a technology-independent supplier of drive systems. With ELIN Motoren, we are able to offer our customers a significant advantage in terms of drivetrain electrification.” Voith and Trasys, the former parent company of ELIN Motoren, signed a sales agreement for ELIN Motoren on December 20, 2019. ELIN Motoren will remain independent as a business and will continue to be active using the established ELIN Motoren brand. As a result, customers of both Voith and ELIN Motoren will continue to have access to the same sales channels. ELIN Motoren GmbH has a total of about 1,000 employees and generates a turnover of about €120 million. The company manufactures electric motors and generators in small series, as well as individualized solutions for industrial applications. In this area, the company focuses on electric machines, motors in the low-voltage, medium-voltage but also in high-voltage range, and generators, in particular for wind energy and decentralized energy generation. With its product portfolio, ELIN Motoren serves the target markets wind energy, plastics, tunnels and mining, oil and gas, plant construction, as well as power plants. “As a globally established expert with many years of experience in the drive technology sector, Voith is pursuing a digitalization strategy for industrial applications, as is ELIN Motoren,” states Wolfgang Landler, CEO of ELIN Motoren GmbH. “The future cooperation between the two companies will allow us to offer significant added value. Together we can develop system solutions and especially technologies in digitalization. We are looking forward to the cooperation with Voith.” ([www.voith.com](http://www.voith.com))

## NES

### IS A FULL-SERVICE PARTNER FOR FAA-PMA BEARINGS CERTIFICATION AND MANUFACTURING

Napoleon Engineering Services (NES) offers Reverse Engineering (RE) of type certified aircraft ball and roller bearings in support of FAA-PMA certification. Additionally, NES is a qualified manufacturer of FAA-PMA bearings. RE of a type certified bearing is the first step in the PMA process. If carried out by a facility with the proper inspection, testing and bearing design capability, it will satisfy the requirements of CFR14 Subpart K and FAA Order 8110.42 under test and computation. NES is a qualified partner in this process.

“We fill in all the gaps for a customer who wants to be a certified PMA holder for an aircraft bearing. By providing a full-service, highly qualified Reverse Engineering team,” says NES President Chris Napoleon “along with the ability to manufacture custom bearings in-house, we are a full-service partner. NES provides a high level of bearing design and manufacturing expertise during the process along with a significant cost-savings to the FAA-PMA holder.” Proper reverse engineering ensures that FAA-PMA aircraft replacement bearings will meet or exceed the same rigorous quality, design and performance standards as those originally specified. To support these requirements, a team of highly experienced NES bearing engineers and technicians perform a thorough physical evaluation of the aircraft bear-

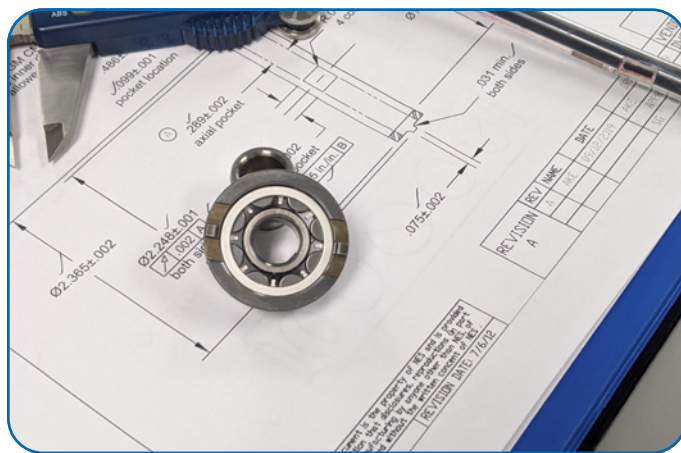

ings, using highly specialized equipment and data analysis tools. The end product is an accurate and detailed analysis which provides all of the necessary inspection data along with a detailed assembly drawing supporting the approval process coupled with manufacturing expertise that ensures that the bearing meets or exceeds the application requirements. PMA, when used in conjunction with a qualified aerospace bearing manufacturer, such as NES, is an excellent way to reduce the overall cost of aircraft and equipment maintenance, repair and overhaul. According to Napoleon, “We are always customer focused, it’s the core of our business model, and as an essential business, we’re fully operational and ready to answer customer calls within two rings day in and day out.” ([www.nesbearings.com](http://www.nesbearings.com))

# Regal Beloit

ANNOUNCES THE LAUNCH OF A MECHANICAL POWER TRANSMISSION PODCAST

Regal Beloit Corporation, a leading manufacturer of electric motors, electrical motion controls, power generation and power transmission components, announced the launch of its new Community News – On the Air podcast series from its Power Transmission Solutions (PTS) unit.



This podcast will share tools, tips and new innovations to help Regal customers address their challenges in mechanical power transmission and achieve more success. In one podcast, Regal reviews how a quarry was able to mitigate flooding risk by predicting the future with Perceptive Technologies 24/7 monitoring; in another, they share how a customer saved \$105,000 by implementing System Plast Speedset Brackets.

“The goal of the podcast is to share customer pain points and discuss how Regal PTS is working to solve problems,” said Carmen Ek, podcast host and distribution marketing manager, Regal. “Ultimately, we want to make our customers and their employees more successful.”

Each podcast is around 7 to 13 minutes long and can be accessed through popular apps like Spotify, Apple or Google podcasts, or directly from a desktop via a modern web browser like Google Chrome, Firefox or Microsoft Edge browsers. ([www.regalbeloit.com/podcasts/pts](http://www.regalbeloit.com/podcasts/pts))

## QuickSilver Controls SilverMax™ Integrated Hybrid Servos

Motor + Encoder + Controller + Driver

High Efficiency Over Wide Speed Range  
Highly Programmable  
Handles Large Inertia Mismatch  
NEMA 23 and 34

Bringing Our 23 years of Hybrid Servo Expertise to Your Project!



 +1 909 599 6291

[www.QuickSilverControls.com](http://www.QuickSilverControls.com)

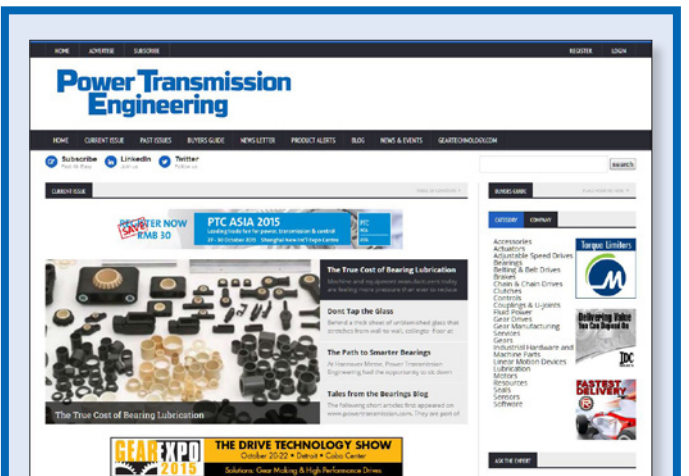

## Power Transmission Engineering

- Technical content free for everyone
- Comprehensive Buyers Guide
- The latest news

[www.powertransmission.com](http://www.powertransmission.com)

# Power Transmission Engineering



**AGMA MEDIA**  
1840 Jarvis Avenue  
Elk Grove Village, IL 60007  
Phone: (847) 437-6604  
Fax: (847) 437-6618

**EDITORIAL**

**Publisher & Editor-in-Chief**

Randy Stott  
stott@agma.org

**Senior Editor**

Jack McGuinn  
mcguinn@agma.org

**Senior Editor**

Matthew Jaster  
jaster@agma.org

**ART**

**Art Director**

David Ropinski  
ropinski@agma.org

**ADVERTISING**

**Advertising Sales Manager**

**& Associate Publisher**  
Dave Friedman  
friedman@agma.org

**China Sales Agent**

Eric Wu  
eric.wu@eastcotec.com

**Materials Coordinator**

Dorothy Fiandaca  
fiandaca@agma.org

**CIRCULATION**

**Circulation Manager**

Carol Tratar  
tratar@agma.org

**ACCOUNTING**

Luann Harrold  
harrold@agma.org

**MANAGEMENT**

**President**

Matthew Croson  
croson@agma.org

**FOUNDER**

Michael Goldstein founded Gear Technology in 1984 and Power Transmission Engineering in 2007, and he served as Publisher and Editor-in-Chief from 1984 through 2019. Michael continues working with both magazines in a consulting role and can be reached via e-mail at [michael@geartechnology.com](mailto:michael@geartechnology.com).

**ABB**

Page 3  
[new.abb.com](http://new.abb.com)

**Andantex**

Page 21  
[andantex.com](http://andantex.com)

**B&R Machine and Gear**

Page 40  
[www.brgear.com](http://www.brgear.com)

**Beyta Gear Service**

Page 2  
[www.beytagear.com](http://www.beytagear.com)

**Brother Gearmotors**

Inside Front Cover  
[BrotherGearmotors.com](http://BrotherGearmotors.com)

**Circle Gear**

Page 12  
[www.circlegear.com](http://www.circlegear.com)

**Designatronics**

Page 27  
[www.qbcbearings.com](http://www.qbcbearings.com)

**Diequa Corp.**

Pages 25, 38  
[www.diequa.com](http://www.diequa.com)

**Forest City Gear**

Page 17  
[www.forestcitygear.com](http://www.forestcitygear.com)

**Hy-Tech Engineered Solutions**

Page 15  
[www.ptggears.com](http://www.ptggears.com)

**ITW Heartland**

Page 15  
[SpiroidGearing.com](http://SpiroidGearing.com)

**JIE USA**

Page 39  
[www.jie-drives.com](http://www.jie-drives.com)

**Kyodo Yushi USA Inc.**

Page 2  
[www.kyodoyushiusa.com](http://www.kyodoyushiusa.com)

**Lubriplate**

Page 37  
[www.lubriplate.com](http://www.lubriplate.com)

**McInnes Rolled Rings**

Page 4  
[www.mcinnesorledrings.com](http://www.mcinnesorledrings.com)

**Molon Motor and Coil**

Page 16  
[www.molon.com](http://www.molon.com)

**Nordex Inc.**

Page 38  
[www.nordex.com](http://www.nordex.com)

**Philadelphia Gear**

Page 23  
[PhilaGear.com/MyMission](http://PhilaGear.com/MyMission)

**Quality Bearings & Components**

Page 27  
[www.qbcbearings.com](http://www.qbcbearings.com)

**Quicksilver Controls**

Page 61  
[www.QuickSilverControls.com](http://www.QuickSilverControls.com)

**R+W America**

Page 7  
[www.rw-america.com](http://www.rw-america.com)

**RBI Bearing Inc.**

Page 5  
[www.rbibearing.com](http://www.rbibearing.com)

**Regal Beloit**

Page 11  
[Regalbeloit.com/McGill](http://Regalbeloit.com/McGill)

**Schaeffler Group**

Back Outside Cover  
[www.schaeffler.us](http://www.schaeffler.us)

**SEW-Eurodrive**

Inside Back Cover  
[www.seweurodrive.com](http://www.seweurodrive.com)

**SMT**

Page 26  
[www.smartmt.com/masta](http://www.smartmt.com/masta)

**WEG Electric Corp.**

Page 53  
[www.weg.net](http://www.weg.net)

**Worldwide Electric Corp.**

Page 19, 31  
[worldwideelectric.net](http://worldwideelectric.net)

**Zero-Max**

Page 13  
[www.zero-max.com](http://www.zero-max.com)



# Power Transmission Engineering®

# FREE SUBSCRIPTION

20PTEALL

## Please Respond

Your response ensures that we deliver the magazine only to those who want it. It also gives us the vital information we need to serve you best.

- YES** I want to receive/continue to receive **Power Transmission Engineering**
- NO** Thanks anyway, but I don't need the world's best publication on mechanical components.

Name \_\_\_\_\_ (please print) Job Title \_\_\_\_\_

Signature \_\_\_\_\_ (required) Date \_\_\_\_\_

## How would you like to receive Power Transmission Engineering?

- PRINT Version (Verify mailing info below)
- DIGITAL Version (E-mail required)
- BOTH Print AND Digital (E-mail required)

E-mail \_\_\_\_\_ \*

**\*You can OPT OUT of your e-mail subscription at any time.**

## How is THIS LOCATION involved with power transmission products? (Check all that apply)

- WE MAKE power transmission products
- WE BUY power transmission products
- WE SELL power transmission products (Distributors, sales reps, etc.)
- WE DESIGN products with power transmission components in them
- Other (please describe) \_\_\_\_\_

What is your company's principal product or service? \_\_\_\_\_

## MAILING INFORMATION

NAME:

JOB TITLE:

COMPANY:

ADDRESS:

- Check if this is a home address

CITY:

STATE/Province:

ZIP/Postal Code:

PHONE:

FAX:

**If your label is incorrect or incomplete, please update it above!**

**FAX to 1-847-437-6618**

SCAN to: [subscribe@powertransmission.com](mailto:subscribe@powertransmission.com)

# 3×3 Puzzle Cubes with Gears

Joseph L. Hazelton, Contributing Editor

Looking at a Gear Cube XXL, you can't help but think about a Rubik's Cube. Both are 3×3 puzzle cubes with brightly colored pieces. Moreover, both are sold commercially as toys.

Created by Oskar van Deventer, the Gear Cube XXL and the smaller Gear Cube are made by Mefferts, a brand of puzzle toys, and are distributed by Recent Toys, Amsterdam, The Netherlands.

You also can't help but notice that Oskar's cube is different from a Rubik's. On Oskar's cube, the pieces have gear tooth shapes on them. This difference goes deeper than the surface. The shapes are actual gear teeth that extend into the puzzle's interior and that mesh and roll with each other. So, even though it looks *like* a Rubik's Cube, Oskar's cube works quite differently.

To understand how Oskar's cube works, though, you have to start with a Rubik's Cube. Holding a Rubik's in your hands, looking at a side, you see nine pieces. The pieces form three columns: a left, a middle, a right. Each column has three pieces. When you work the cube, you turn one column, say the right column, while you hold the left and middle columns steady.

With Oskar's cube, when you turn the right column, the middle column also turns. Now, both columns turn in the same direction, but the middle one turns at half-speed. So, if you do two full turns of the right column, the middle column will do one full turn.

Also, because the teeth mesh and rotate, they end up with a different orientation than they had when you started turning the right column. So, you'd have to do many double full turns of the right column to compensate for the turning of the middle column.

With all that turning, meshing, and rotating, you may think Oskar's cube would be hard to solve. "It looks very difficult," Oskar says, "but it is actually easier to solve because the gears limit how far one can scramble it."

From the start, the gears were the special part, the wrinkle, in the cube's design. Back then, the cube was a design challenge between friends, an impossible design challenge.

In 2007, in July, Oskar was in Brisbane, Australia. He had traveled from his hometown, Leidschendam, The Netherlands, to attend an annual event. An electrical engineer, Oskar works in information and communication technology. The event, though, was about his hobby.

Oskar is a puzzle enthusiast: "I have been designing mechanical puzzles since I was 12 years old." The event was the International Puzzle Party. Naturally, Oskar ran into a number of friends, fellow puzzle enthusiasts. One of them, Bram Cohen, had a design challenge for Oskar.

Specifically, the challenge was: Create a 2×2 puzzle cube with an inner mechanism that is symmetrical and is generic—that is, can be used in different puzzles, like a 2×2 or a 3×3. For puzzle designers, a 2×2 cube with a generic, symmetrical inner mechanism isn't a new challenge. It's an *ultimate* challenge: "It is like our moonshot," Oskar says.

To explain, Oskar starts with a Rubik's Cube. As a 3×3, a Rubik's uses an inner mechanism that's symmetrical. With a regular 2×2 cube, the inner mechanism isn't symmetrical. Rather, it's a doctored 3×3 in which some parts have been glued together. So, in Bram's challenge, symmetry was one degree of difficulty, genericness was the second degree. The third was Bram's wrinkle on the mechanism's design. "He had the idea of having something that is geared," Oskar says.

The challenge wasn't a surprise. Puzzle designers often give fun challenges to each other as part of their hobby. Bram's wrinkle wasn't a surprise, either. "Bram is the guy with the crazy ideas," Oskar says.

So, Oskar took up the challenge, with mixed results. "I could not answer Bram's puzzle-design challenge," he says, "but

I managed to build a 3×3 Rubik's Cube with gears inside. Then, it hit me that I should expose

those gears at the outside." This last design became the Gear Cube and the Gear Cube XXL.

Oskar's cube, however, is only one of his geared inventions. Others can be seen in videos on his YouTube channel, OskarPuzzle. Now, Oskar has created hundreds of puzzles, so his channel has hundreds of videos. "My hobby is puzzle designing," he says, "and I do a lot of that." **PTE**

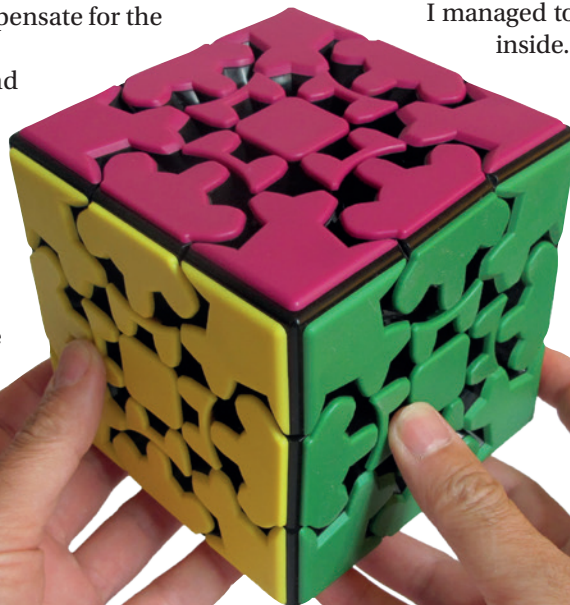

The Gear Cube XXL is a 3×3 puzzle cube that uses a geared mechanism for turning the sides and pieces. The XXL is the cube's large version, with sides of 4¾"×4¾". The cube's small version has sides of 2½"×2½". (Photo courtesy of Recent Toys)

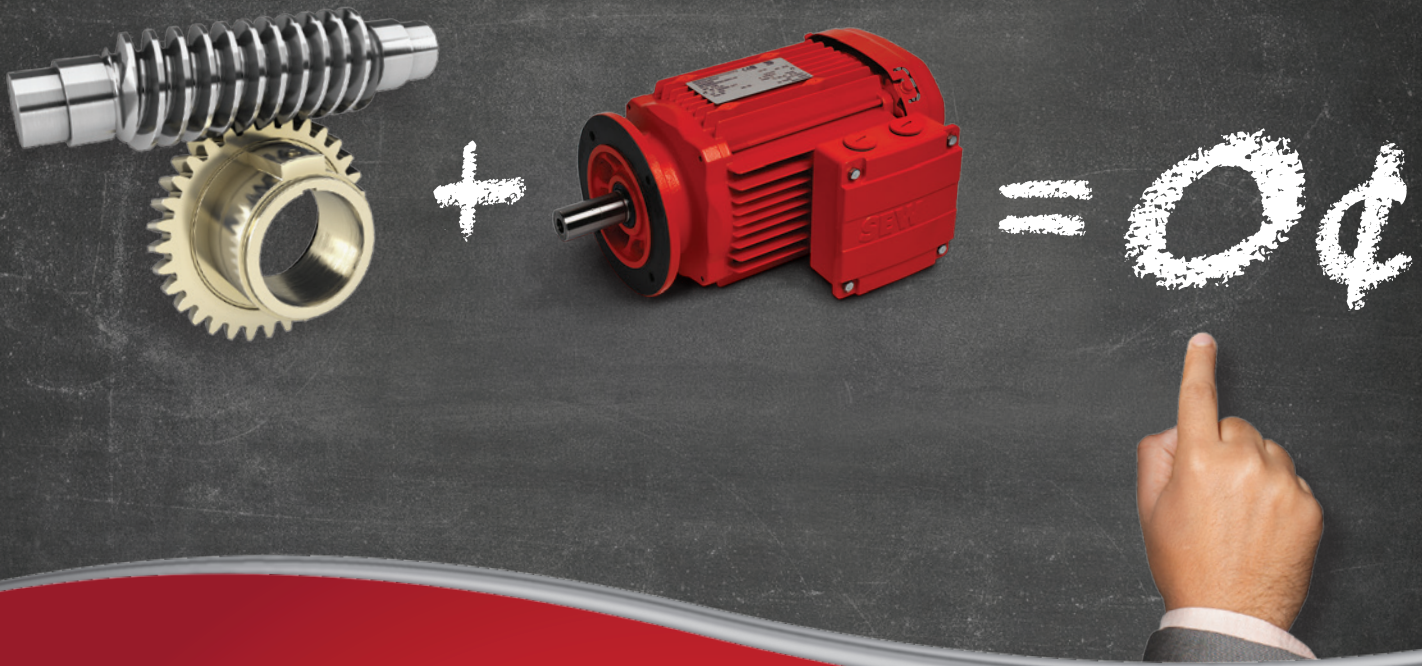

## Makes no cents!

Adding an inefficient single-stage worm gearbox to a premium efficient motor doesn't make sense if you are trying to save money.

Why gain 2-3% energy savings with a more efficient motor and then lose 50% or more through the worm gear?

**Solution:** Use a helical-bevel gearmotor from SEW-EURODRIVE and obtain 96% efficiency. Now that makes a lot of cents!

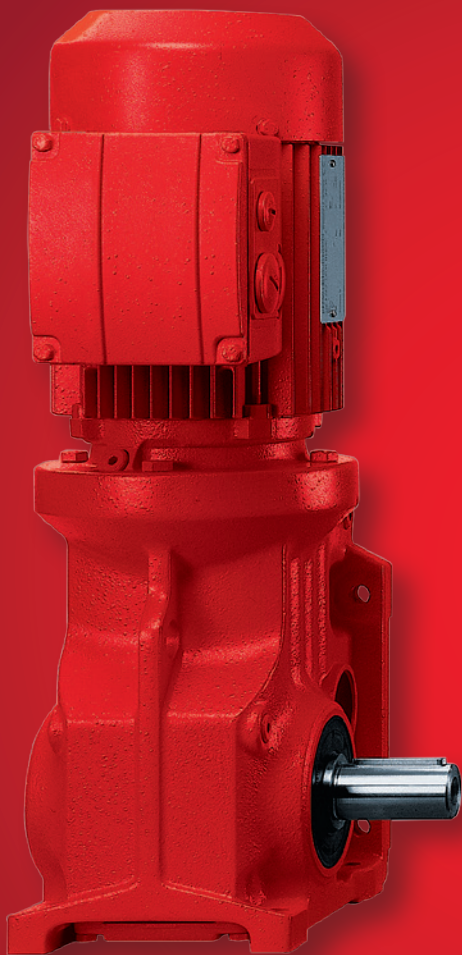

# Single-Row or Double-Row? With Schaeffler X-life™ Angular Contact Ball Bearings, the Answer Is Always “Yes!”



**FAG**

X-life single-row angular contact ball bearings from Schaeffler offer up to 30% higher dynamic load rating, as much as 50% longer rating life, and up to 10% less friction vs. conventional bearings. Need high thrust capacity in both directions? Choose Schaeffler's latest generation of double-row angular contact ball bearings – now available with a hardened, black oxide-coated steel cage.

Either way, Schaeffler-exclusive X-life features deliver increased load capacity, greater stiffness, superfinished raceway surfaces and improved geometry.