

# Power Transmission Engineering®

MARCH 2021

## AUTOMATION

- SAFETY IN MOTION CONTROL
- MECHATRONIC SUBASSEMBLIES
- DIGITAL FILTERING





**You could always rely on your brother for the best protection.**

**You still can. With Brother Gearmotor's industry-best 5-year limited warranty, you can be assured of the best protection and performance on every standard model.**



With premium protection comes the ultimate peace of mind. That's why Brother leads the way once again, by shielding its entire line of standard gearmotors with the industry's best warranty. No matter how far the journey or how rough the path, rest assured you've got the protection you need right at your side. Brother...we've got your back.

**Call us today for a sample gearmotor to try out.**

**brother**  
at your side

866.523.6283  
BrotherGearmotors.com

# Power Transmission Engineering®

MARCH 2021



A Publication of  
The American Gear  
Manufacturers Association

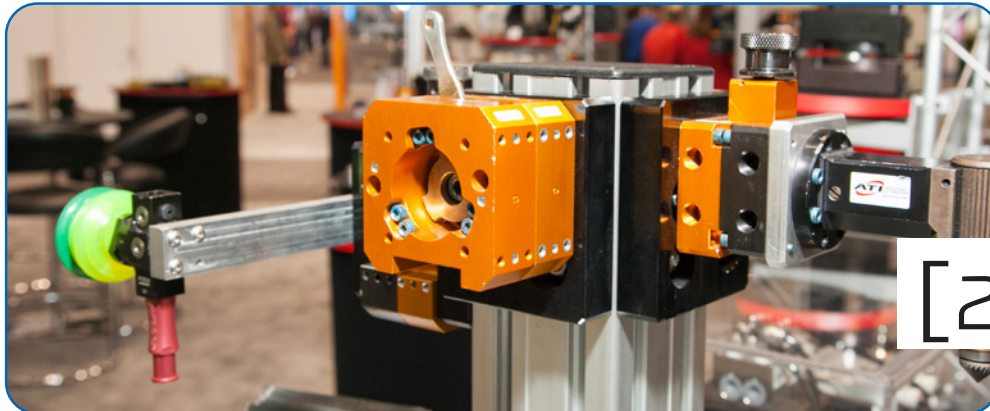

## FEATURE ARTICLES

- [22] **Examining Functional Safety in Motion Control Applications**  
The increased complexity of components as well as the need for system integration continues to challenge machine designers today.
- [26] **The Influence of Bevel Pinion Retractability on Casing Design**  
The intuitive modeling techniques in the FVA-Workbench guarantee consistent, valid, and manufacturable gears every time.
- [30] **Mechatronic Subassemblies for Factory Automation**  
Fully integrated mechatronic subassemblies provide versatile and cost-effective solutions for factory automation applications.

## TECHNICAL ARTICLES

- [42] **A Ten-Minute Introduction to Digital Filters**  
Filtering is needed in various control and communication Applications.
- [46] **Analysis of the Operational Behavior of a High-Speed Planetary Gear Stage for Electric Heavy-Duty Trucks in Multi-Body Simulation**  
The presented method offers a possibility for the quantitative evaluation of the operational behavior of integrated transmission systems.

## Stay Connected



Follow us on Twitter  
[twitter.com/#!/PowerTransMag](https://twitter.com/#!/PowerTransMag)



Connect with us on LinkedIn  
[www.linkedin.com/groups/Power-Transmission-Engineering-PTE-2950055](https://www.linkedin.com/groups/Power-Transmission-Engineering-PTE-2950055)



Subscribe Online  
[www.powertransmission.com/subscribe.htm](https://www.powertransmission.com/subscribe.htm)

Vol. 15, No. 2. POWER TRANSMISSION ENGINEERING (ISSN 2331-2483) is published monthly except in January, May, July and November by The American Gear Manufacturers Association, 1840 Jarvis Ave., Elk Grove Village, IL 60007, (847) 437-6604. Cover price \$7.00. U.S.

Periodicals Postage Paid at Elk Grove Village IL and at additional mailing offices. Send address changes to POWER TRANSMISSION ENGINEERING, 1840 Jarvis Ave., Elk Grove Village, IL 60007.

The American Gear Manufacturers Association makes every effort to ensure that the processes described in POWER TRANSMISSION ENGINEERING conform to sound engineering practice. Neither the authors nor the publisher can be held responsible for injuries sustained while following the procedures described. Postmaster: Send address changes to POWER TRANSMISSION ENGINEERING, 1840 Jarvis Avenue, Elk Grove Village, IL, 60007. ©2020 Contents copyrighted by THE AMERICAN GEAR MANUFACTURERS ASSOCIATION. No part of this publication may be reproduced or transmitted in any form or by any means, electronic or mechanical, including photocopying, recording, or by any information storage and retrieval system, without permission in writing from the publisher. Contents of ads are subject to Publisher's approval.

# Power Transmission Engineering

VOL. 15, NO. 2

## QuickSilver Controls silverMax™

### Integrated Hybrid Servos

Motor + Encoder + Controller + Driver

High Efficiency Over Wide Speed Range

Highly Programmable

Handles Large Inertia Mismatch

NEMA 23 and 34

Bringing Our 23 years of  
Hybrid Servo Expertise  
to Your Project!



+1 909 599 6291

[www.QuickSilverControls.com](http://www.QuickSilverControls.com)



## BEYTA GEAR SERVICE



### PUTTING A LIFETIME

OF

## GEAR DESIGN EXPERIENCE

### TO WORK FOR YOU

- Reverse engineering
- Gearbox upgrades
- Custom gearbox design
- Specification development
- Project management
- Vendor qualification
- Design reviews
- Bid evaluations
- Tooling design
- Customized gear training
- Equipment evaluation
- Custom machine design

**Charles D. Schultz**  
[chuck@beytagear.com](mailto:chuck@beytagear.com)  
[630] 209-1652

[www.beytagear.com](http://www.beytagear.com)

### [06] PTEExtras

**PTE Videos:** Stop Position Simulation with **ABB**; Motionworks with **Yaskawa America**. Events: **Hannover Messe** (Digital Version); **ABMA's** Lubrication and Wear, Advanced Concepts.

### [08] Publisher's Page

What's Your Story?

### [08] Product News

**Schaeffler** starts mass production of electric motors; **KTR Corporation** develops EVOLASTIC coupling; **ABB** HMI and drive faceplates provide comprehensive views into automation systems; **Faulhaber** offers drive solutions for robotics industry; **Drivetrain Hub** launches gears app; **Miki Pulley Brakes** assist with satellite control positioning; **Goodyear Belts** produces belts for the automotive and industrial markets

### [37] Engineering sMART

Products and services marketplace.

### [56] Industry News

**Nidec Corporation** To Acquire **Mitsubishi Heavy Industries Machine Tool Co., Ltd.**; **CC-Link Partner Association** examines TSN benefits in manufacturing; **Schaeffler's** Jeff Hemphill Assumes Presidency of SAE International; **EASA** offers guide for motor repairs; **QuesTek** awarded material development funding for energy applications

### [62] Advertiser Index

Contact information for every advertiser in this issue.

### [63] Subscriptions

Renew your free subscription today.

### [64] Power Play

An Inside Look at Bell's EDAT System.



Cover image courtesy of Bosch Rexroth Corp



***PRECISE. ROBUST. AVAILABLE.***

### **CD® Couplings**

- Zero-Backlash & High Torsional Stiffness
- Engineered Performance for Reliable 24/7 Operation
- Servo-Rated for Reversing, Positioning & Precision
- Single-Flex, Double-Flex, Floating-Shaft Solutions
- Standard Models / Fully **Customizable**
- Engineering Assistance / **Fast** Delivery



[www.zero-max.com](http://www.zero-max.com) 800.533.1731

**ZERO-MAX®**

**PTE Videos****Stop Position Simulation with ABB**

ABB's RobotStudio now offers new virtual robot braking distance function to create an exact simulation of the real-world stopping distance of a robot, improving safety and reducing the footprint of robotic cells. Learn more here:

*Stop Position Simulation with ABB (powertransmission.com)*

**MotionWorks with Yaskawa America**

This Yaskawa America video demonstrates and explains a few programming tips to help users understand the Hardware configuration in MotionWorks. Learn more here:

*Hardware Configuration in MotionWorks (powertransmission.com)*

**Event Spotlight: Hannover Messe 2021 (Digital Edition)**

The digital Hannover Messe will focus on a comprehensive conference program, the digitization of product presentations and software-based business dating. Topics will include AI, security, digital platforms, Industry 4.0, logistics 4.0, robotics, automation, motion control and more.

**HANNOVER MESSE**

**Lubrication & Wear: Advanced Concepts**

takes place May 25-27, 2021 at Daley College, Chicago. This ABMA bearing technology course is designed for engineers and scientists in the rolling element bearing, gear, and power transmission industries who desire a more fundamental knowledge of component-relevant topics in the field of tribology.

[www.americanbearings.org/page/LubricationWear](http://www.americanbearings.org/page/LubricationWear)

**Power Transmission Engineering**

**AGMA MEDIA**  
1840 Jarvis Avenue  
Elk Grove Village, IL 60007  
Phone: (847) 437-6604  
Fax: (847) 437-6618

**EDITORIAL****Publisher & Editor-in-Chief**

Randy Stott  
stott@agma.org

**Senior Editor**

Jack McGuinn  
mcguinn@agma.org

**Senior Editor**

Matthew Jaster  
jaster@agma.org

**ART****Art Director**

David Ropinski  
ropinski@agma.org

**ADVERTISING****Advertising Sales Manager & Associate Publisher**

Dave Friedman  
friedman@agma.org

**China Sales Agent**

Eric Wu  
eric.wu@eastcotec.com

**Materials Coordinator**

Dorothy Fiandaca  
fiandaca@agma.org

**CIRCULATION****Circulation Manager**

Carol Tratar  
tratar@agma.org

**ACCOUNTING**

Luann Harrold  
harrold@agma.org

**MANAGEMENT****President**

Matthew Croson  
croson@agma.org

**FOUNDER**

Michael Goldstein founded Gear Technology in 1984 and Power Transmission Engineering in 2007, and he served as Publisher and Editor-in-Chief from 1984 through 2019. Michael continues working with both magazines in a consulting role and can be reached via e-mail at [michael@geartechnology.com](mailto:michael@geartechnology.com).



# EXTREME ENVIRONMENTS CALL FOR RESILIENT & RELIABLE MOUNTED SPHERICAL UNITS.

Harsh environments need a resilient and reliable spherical roller bearing housed unit that can stand up to tough conditions. RBI Bearing's line of Mounted Spherical Units are designed to withstand challenging environmental conditions, such as, impacts from aggregate, extreme temperatures, heavy load conditions and misalignment. Available with Armor Bearing Technology & Protection to reduce bearing friction and substantially increase bearing life. Contact RBI Bearing for pricing.

[www.rbibearing.com](http://www.rbibearing.com) 1-800-708-2128

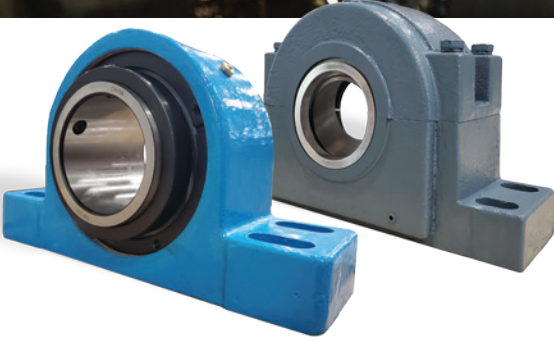

# What's Your Story?



*Power Transmission Engineering* is looking for a few good writers. Or even just a few good ideas. You see, we're always looking for a good story to tell.

But before you send me the story about how your great-great-grandfather was the walking champion of England at age 16 or some other such yarn, interesting as it may be, let's remember our focus.

*Power Transmission Engineering* is the magazine of mechanical components. So while we're definitely looking for interesting stories, we most want to hear about the technology of gears, bearings, electric motors and related components, and how they're being used to create better, more efficient, more productive machines.

And if there's an interesting personality or unique angle to the story, so much the better.

There are thousands upon thousands of cool and interesting applications involving mechanical power transmission components being developed and worked on every day. And some of you are the ones doing the work.

We need you to share those stories with us so we can share them with your peers around the world.

Show us how you're using technology in a creative way. Help us inspire your fellow engineers to create better products, processes and solutions. Show us how you're using mechanical devices to improve efficiency, increase productivity or solve problems that haven't been solved before.

Chances are, there are many others like you who could learn from what you're doing.

And don't forget, what's cool to us doesn't need to be some drama-filled saga worthy of Netflix, Hulu or whatever is your favorite streaming platform. When we say cool, we're looking for things that would be cool to other engineers.

We're looking for how-to. We're looking for practical explanations of theory. We're looking for the basics.

One of our goals is to provide the technical background reading for those new to our industry or those who just need to brush up. Help us train the next generation of engineers and end users of mechanical power transmission and motion control components.

Not sure if you have a story to tell or an idea that we could use? No worries! Just strike up a conversation with one of our editors and we'll help you flesh it out. We're always there at major industry events - like the upcoming AGMA/ABMA annual meeting or the Motion+Power Technology Expo (Sept. 14-16 in St. Louis). We're also happy to take your phone calls or e-mails.

If you still need inspiration, you should take a look at our Editorial Guidelines at [www.powertransmission.com/PTE-Contribute-2021.pdf](http://www.powertransmission.com/PTE-Contribute-2021.pdf). There you'll find the list of subjects we're planning to cover throughout the year, along with an overall focus or theme for each issue. You'll also find a description of the various types of articles we need - from basic news items to in-depth technical articles.

Send us your ideas:

[mcguinn@agma.org](mailto:mcguinn@agma.org) - Jack McGuinn, Senior Editor - for technical articles or Ask the Expert. If you've presented something related at a technical conference or created a white paper that might be adapted, Jack would love to hear from you.

[jaster@agma.org](mailto:jaster@agma.org) - Matt Jaster, Senior Editor - for feature articles, case studies, interview ideas and pretty much anything else. Matt will help you see and share with others what's cool about the applications you're working with.

[stott@agma.org](mailto:stott@agma.org) - that's me, and I'd love to hear about *any* ideas you have. And if you want to know about my great-great-grandfather (who was, in fact, the walking champion of England at age 16 - and quite the character besides), just ask!



**GROVE GEAR®**



## THE HEAVY DUTY WORKHORSE OF GEAR REDUCERS

The Grove Gear® IRONMAN® gear reducer handles the environmental assaults, shock loading, frequent reversing and continuous duty cycles typical in many industrial applications. Designed to be the premium worm reducer in the industry, IRONMAN reducers feature one-piece cast iron housings with single output cover design, Viton® double lip seals for extended life through increased resistance to harsh conditions, large oil capacity, oversized high-speed bearings and more.

For more information, visit

[regalbeloit.com/IRONMAN](http://regalbeloit.com/IRONMAN)  
Creating a better tomorrow™ ...

Viton is believed to be the trademark and/or trade name of The Chemours Company.  
Regal, Creating a better tomorrow, Grove Gear and IRONMAN are trademarks of Regal Beloit Corporation or one of its affiliated companies.  
© 2021 Regal Beloit Corporation, All Rights Reserved. MCAD20069E • 10398E

**REGAL®**

# Schaeffler

## STARTS MASS PRODUCTION OF ELECTRIC MOTORS

Schaeffler is now reaping the rewards of its decision to create a specific business division for electric mobility three years ago, at the beginning of 2018. The start of mass production for multiple products across all electrification levels is testimony to Schaeffler's successful engagement in the electric mobility arena and to its status as the technology partner for advancing how the world moves.

"We have successfully transformed ourselves into a drive system supplier for sustainable electric mobility solutions and established ourselves as a reliable partner for our customers," says Matthias Zink, CEO Automotive Technologies at Schaeffler AG. Schaeffler's key point of difference is its know-how on components and system levels. "We have been engaged with electric mobility for more than 20 years and we understand the drive train requirements. Our innovation capacity as a global automotive and industrial supplier plus our strong industrial skills make us a preferred partner for our customers."

Over the last few years, Schaeffler has progressively strengthened its electric mobility expertise through a series of targeted acquisitions. The purchase of Elmotec Statomat at the end of 2018 added new expertise in winding technology, providing Schaeffler with comprehensive coverage of all aspects of electric motor industrialization. Another highly successful acquisition back in 2016 was the takeover of Compact Dynamics, a specialist in the development of innovative electric drive concepts. Meanwhile, the Schaeffler Paravan Technologie joint venture is developing the Space Drive steer-by-wire system, a key technology for autonomous driving.

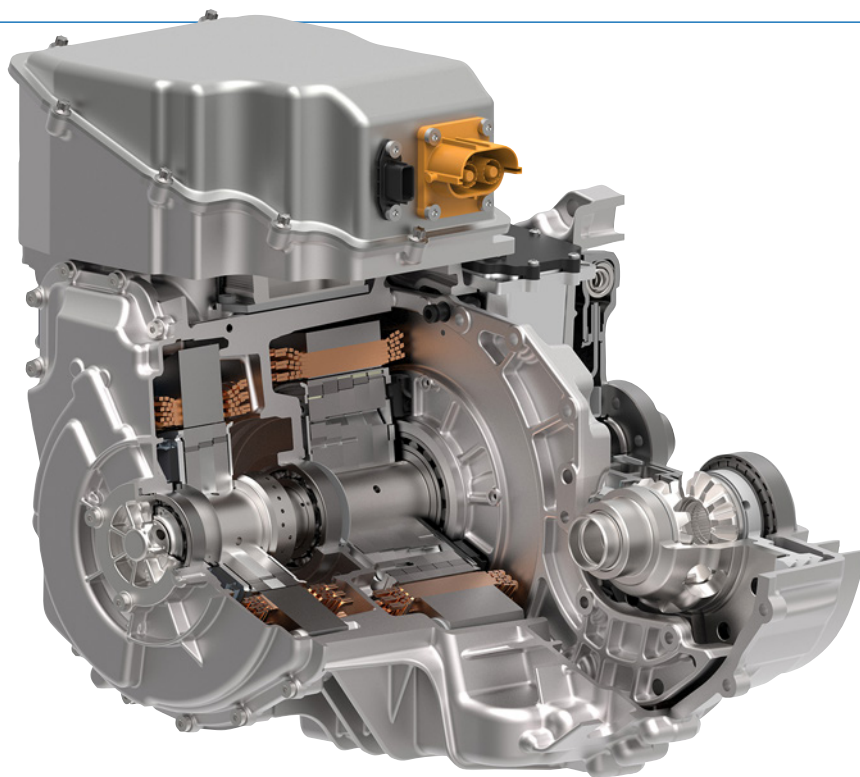

### Mass production solutions across all levels of electrification

Schaeffler supplies technologies for all electrified drive trains. Mass production of the electric axle transmission, a key component of electric axle systems, has been running successfully since 2017, providing optimum transmission ratios and power transfer from the electric motor to the wheels. This is a highly versatile component with a wide range of applications. In the Audi e-tron, for example, Schaeffler electric axle transmissions, with different structural designs, are used on both axles for all-wheel drive capability. And the Porsche Taycan is fitted with a high-efficiency Schaeffler coaxial electric axle transmission to provide the required transmission ratio on the front axle. In 2020, the coaxial electric axle transmission earned Schaeffler the prestigious PACE Award, regarded by the industry worldwide as

the hallmark for successful automotive projects. Schaeffler has also secured multiple orders for its complete "3in1 electric axles," which combine the electric motor, drive unit and power electronics in a single system. These are high-performance electric axles with advanced power density.

### Electric motors: Start of mass production

This year will see the start of the mass production of hybrid modules, hybrid drive units and all-electric axle transmissions. The basis of Schaeffler's electric motor production is a modular, highly integrated technology platform. Schaeffler's strong expertise in the areas of production and technology across all components of electric drive systems is the key to the successful industrialization of products that are both technologically advanced and highly profitable. Along with a series of mass production orders for electric motors in the passenger car sector, Schaeffler has recently reached another milestone by entering the heavy-duty applications segment for commercial vehicles. Schaeffler has announced a mass production order for electric motors featuring wave winding technology, a technology that provides high power density as well as advantages during assembly.

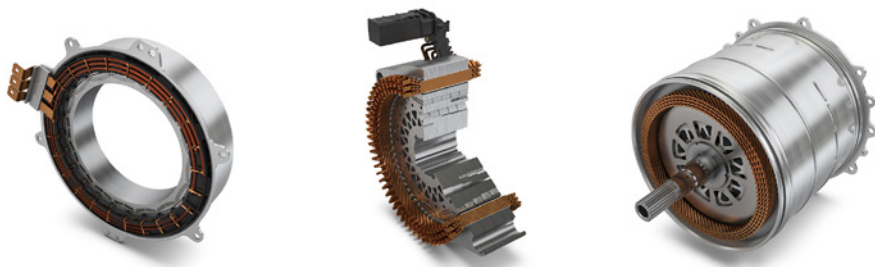

We deliver precision gears, high-quality machined parts, and molded components for thousands of applications.

- Prototype
- High-Volume Production
- Custom Design
- Engineering Support
- Precision Manufacturing
- Assembly



ISO 9001:2015 | AS9100D  
ITAR Compliant - DDTC Registered  
DFARS Compliant  
NIST SP 800-171 Compliant

**CNC Swiss Turning | CNC Milling & Turning | Gear Cutting | Bevel Gear Cutting**  
**Rapid Tooth Cutting Only Capability**



As an online engineering resource, SDP/SI provides:  
Engineered Mechanical Solutions  
Design Tools and Calculations  
Product Specifications  
3D CAD Models

Shop with us 24/7  
87,000 Component Choices  
Gears, Timing Belts, Pulleys, Couplings, and More

**SDP/SI looks forward to working with you!**  
Send an RFQ – we can quote from a  
3D model or drawing

For Metric Gears or Bearings, Check into our sister companies:



Supplying North America  
with Metric Gears  
<https://qtcgears.com>



The Bearing Marketplace  
<https://qbcbearings.com>

## Record order for dedicated hybrid drives

As reported last year, Schaeffler has received a record order for dedicated hybrid drives. From 2024, Schaeffler will deliver an entire drive unit comprising two electric motors and transmission with integrated power electronics. A system power rating of 120 kW offers sports-car like performance with low fuel consumption. "We are making excellent progress," says Dr. Jochen Schröder, president of the E-Mobility

business division. "Our modular product portfolio enables us to offer customized volume-production solutions to meet any customer requirement," Dr. Schröder continues. These successes in the E-Mobility business division reflect the company's high standing as an automotive and industrial supplier in general. Schaeffler is a component, system and service supplier, as its comprehensive product portfolio illustrates.

[www.schaeffler.us](http://www.schaeffler.us)



### Your Objective:

One face in perfect alignment with another. *For infinity.*

### No problems. No distress. No delays.

That's the same objective you have for choosing your gear producer. Circle Gear's objective is to engage with every customer's objectives.

- ▶ One to 1000 gears
- ▶ Customer designed or reverse engineered
- ▶ Gearbox repair, rebuild or redesign
- ▶ OEM or end-users
- ▶ ISO 9001:2015 Certified

1501 S. 55th Court, Cicero, IL 60804  
 (800) 637-9335  
 (708) 652-1000 / Fax: (708) 652-1100  
[sales@circlegear.com](mailto:sales@circlegear.com)  
[www.circlegear.com](http://www.circlegear.com)



Spiral and Straight Bevel Gears (*Cut, Ground or Lapped*) • Spur Gears • Helical Gears • Long Shafts • Herringbone Gears • Involute and Straight Sided Splines • Internal Gears • Worm and Worm Gears • Racks • Sprockets • ISO Certified



Partnering with QualityReducer to provide Gearbox repair, rebuilding and reverse-engineering.

## ABB

HMI AND DRIVE FACEPLATES PROVIDE COMPREHENSIVE VIEWS INTO AUTOMATION SYSTEMS

The CP600 Gen2 HMI with Drive Faceplates provides a NEMA 4X rating, brighter screens, additional communication ports and integral web server capability with faceplates to expand and customize operator views.

ABB's CP600 Gen 2 HMIs offer NEMA 4X rating, an expanded temperature range, 33% brighter screens, additional communications ports and integral web server capability, allowing users to expand HMI usage into more applications. Available in 7", 10" and 15" sizes, the CP600 Gen2 HMI units join the CP600-eCo units and the CP600-Pro units to cover the full range of industrial display needs. The economical CP600-eCo control panel, with screen sizes from 4.3" to 10.1" widescreen, is aimed for basic to standard functions and high usability for clear interaction with the operation process. The CP600-Pro HMI, with screen sizes from 5" to 21.5" widescreen, comes with high end

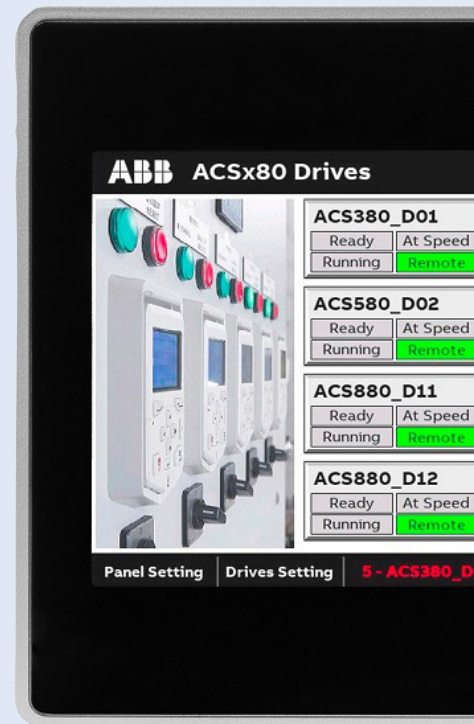

visualization performance, multi-touch operation, versatile trendsetting communication, and representative design.

With innovative Drive Faceplates, the ABB CP600 HMI expands drive operator interface options for ABB's All-Compatible Drives. Connected to one drive, or across a network of drives, these easy-to-use Faceplates provide the most commonly needed control, monitoring and diagnostic functions. Simple configuration enables users to monitor, control and diagnose up to eight drives, and by using ABB's Panel Builder 600 engineering tool, they can easily expand communications to even more drives. Expansion can be as simple as adding one additional parameter on a prewritten Faceplate, or adding a complete set of machine specific faceplates with complex graphics and company logos.

[new.abb.com/drives](http://new.abb.com/drives)

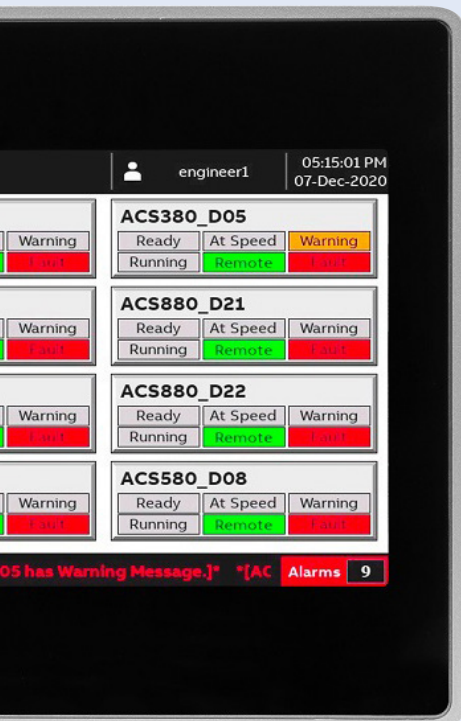

# KTR Corporation

DEVELOPS EVOLASTIC COUPLING

KTR developed a new all-purpose coupling for use in a broad range of applications from main to auxiliary drives in construction equipment and general industry. The zero-backlash and torsionally soft EVOLASTIC is available in ten base sizes and with variants in between covering nominal torques from 100 to 5,600 Nm. Spacers for large DBSE (distance between shaft ends) applications are also available.

The heart of the EVOLASTIC is a new, non-shear elastomer element that transmits torque through integrated aluminum jaw inside the optimized rubber profile. The elastomer is securely fastened to the hub and flange by radial and axial bolts which creates a designed prestress (similar to high strength concrete) that assures reliable torque transmission. The coupling requires low maintenance and



## INDUSTRY READY

### MOTORS, CONTROLS, AND GEAR REDUCERS



**WorldWide Electric's SSHdR Series Stainless Steel Gear Reducers are now BISSC Certified!** The SSHdR Series features IP69K Protection for close-range high pressure, high temperature spray downs and magnetic hardware for metal detection purposes. An affordable alternative to most major brands, the SSHdR Series comes backed with a 1 year warranty.

**Superior Customer Support**  
Driven to provide the best possible customer experience

**In Stock When You Need It**  
\$30M in inventory stocked at 6 regional warehouses

**Proven Quality & Affordability**  
Premium motors, controls, & gear reducers at competitive prices

**Same-Day Shipping Available**  
Most orders placed before 2PM local warehouse time can ship same-day.

Call us or visit us online!  
**(800) 808-2131 / [worldwideelectric.net](http://worldwideelectric.net)**

WorldWide Electric Corporation | 3540 Winton Place, Rochester, NY 14623  
Distribution Centers located in Allentown, PA | Atlanta, GA | Dallas, TX | Indianapolis, IN | Los Angeles, CA | Seattle, WA

compensates for permanent angular misalignments of up to 3° in a single plane while being able to accommodate significantly higher multi-plane misalignments than standard designs.



“Owing to its torsionally soft characteristics, the EVOLASTIC attains the requested vibration and acoustic insulation in the drive train. Besides torque transmission, the coupling also compensates for axial, radial and angular misalignment and absorbs overloads elastically,” said Jochen Exner, innovation manager at KTR’s think tank in Hilden, Germany.

The EVOLASTIC is the first new product release to evolve from KTR’s think tank which opened in 2019 and whose sole focus is new products.

[www.ktr.com/us](http://www.ktr.com/us)

## Faulhaber

OFFERS DRIVE SOLUTIONS FOR ROBOTICS INDUSTRY

Today, a world without robots is inconceivable. The areas of application that require process safety, reliability and economic efficiency from these robots are equally manifold. The drive systems from Faulhaber play a major role in fulfilling these requirements, and they continue to impress with their durability and performance in a robust and compact design. Due to these features, the drive systems can be used in a wide range of applications, from sewer robots and remote-controlled manipulators to robots for handling and logistics to surgical applications or prostheses. Whether high dynamics or precise positioning are needed, with its extensive range of products with more than 25 million possible combinations of microdrives, optical, magnetic or absolute encoders as well as speed and motion controllers with various interfaces, Faulhaber almost always has the perfect solution. At the same time, this technological construction kit is the basis upon which application-specific custom requests are realized, thus facilitating the further evolution of robotics.

In the past, small grippers that are both fast and powerful were always pneumatic. Because with compressed air, large amounts of pressure can be conveyed virtually without any time lag. But the elaborate infrastructure

that was required for pneumatics is no longer needed today. Mechatronic gripping systems can now easily achieve the performance of their pneumatic counterparts thanks to brushless DC-motors with a diameter of only 22 mm and an integrated motion controller.

Microdrives are also used in sewer systems. DC-motors with a diameter of just 15 mm and a precious metal commutation system mounted on inspection robots demonstrate how overload and shock-resistant as well as robust they are in daily use. The small drives confirm these characteristics in logistics as well. In this industry, an increasing number of work steps related to storing, retrieving and preparing items for dispatch is handled by intelligent robots. A typical unit comprising a lifting column and gripper used on a logistics robot contains a drive unit consisting of, e.g., brushless DC-servomotors with integrated Motion Controller and planetary gearhead. When used in the lifting column, for example, this combination ensures precise positioning during storage or retrieval – all during continuous operation with constant load changes. The small Faulhaber drive systems are thus represented in almost all areas of robotics.

[www.faulhaber.com](http://www.faulhaber.com)



Faulhaber provides drive solutions for the robotics industry including DC servomotors with motion controllers.

# Drivetrain Hub

## LAUNCHES GEARS APP

Drivetrain Hub has launched its fully web-based gear software, Gears App.

Gears App is the only Software-as-a-Service (SaaS) gear development platform that integrates gear system modeling, design-for-manufacturing, industry standards, powerflow analyses, CAD,

FE, 3D printing, manufacturing, data management, and collaboration tools. Model, analyze, and build gear systems for parallel-axis and planetary architectures.

Gears App is accessible online from anywhere on any operating system, no special hardware, software, or complicated license

required. It is the only professional gear engineering software made available as an affordable monthly subscription service, entirely online. Just open your web browser and start using it.

[drivetrainhub.com/gears](http://drivetrainhub.com/gears)



A Better Way to Buy Gearboxes  
[Shop.Bonfiglioli](http://Shop.Bonfiglioli)

DISCOVER MORE



 **Bonfiglioli**

Follow Us on Social Media to Learn More:     
or Visit Us at [Shop.Bonfiglioli.com](http://Shop.Bonfiglioli.com)

**MOLON**  
MOTOR & COIL CORPORATION

NEW PRODUCT LINE  
**BRUSHLESS DC  
MOTORS &  
GEARMOTORS**



VISIT OUR WEBSITE:



[www.Molon.com](http://www.Molon.com)



CERTIFIED  
ISO 9001: 2015  
CERTIFICATE NO:  
10001749 QM15



CERTIFIED  
ISO 13485:2016  
CERTIFICATE NO:  
10001749 MP2106

# SICK and Ibeo

COLLABORATE ON LIDAR SENSOR FOR AUTOMOTIVE APPLICATIONS

A technology partnership between Hamburg-based automotive LiDAR specialist Ibeo Automotive Systems GmbH and SICK AG has resulted in a 3D solid-state LiDAR sensor for industrial applications. The technology, developed by Ibeo to automotive standards, is based on a new photon laser measurement technique and is entirely free of moving parts. An additional, camera-like reference image adds a 'fourth dimension' to the measurement provided by the sensor.

The market for autonomous and semi-autonomous systems in an industrial context is predicted to grow at above-average rates. There is particular demand here for tough, ever-smaller and above all cost-efficient sensor solutions. The new solid-state technology from Ibeo works entirely without moving parts and features a compact form factor, thereby offering decisive advantages for mobile applications.

Now Ibeo and SICK have announced a technology partnership to develop a 3D LiDAR sensor based on this innovative solid-state technology from the automotive sector, for industrial applications. In this partnership, Ibeo is providing its ibeoNEXT measurement core. SICK will develop the system design and the application software for a new industrial LiDAR sensor so that industrial applications can be created

to meet customer requirements.

"Autonomous systems will bring increasing changes to the industrial sector in coming years. Even outside industrial facilities there is much potential in mobile applications for the implementation of intelligent sensor solutions. The partnership with Ibeo will enable us to use a robust and highly-developed technology from the automotive segment for future-ready industrial applications," says Dr. Robert Bauer, chairman of the executive board of SICK AG.

"Working together with SICK, we are making an automotive LiDAR sensor available on a large scale for industrial applications for the first time. In the industrial sector this is one of the largest LiDAR cooperation agreements ever concluded. Customers will profit from ibeoNEXT's close-to-production development based on automotive standards and the high-quality standards that result from this, as well as the scale effects associated with it," adds Dr. Ulrich Lages, CEO of Ibeo Automotive Systems GmbH. "We have had a long and close working relationship with SICK. Its extensive and in-depth application knowledge in the area of industrial applications and markets makes SICK an ideal partner to enable us to serve industrial markets."

The ibeoNEXT measurement core





# Miki Pulley

## BRAKES ASSIST WITH SATELLITE CONTROL POSITIONING

was developed for large-scale automotive production and is based on an entirely new photon laser measurement technique for measuring the spatial distance of objects in medium to long ranges. Even in adverse environmental conditions, such as precipitation, or in situations subject to high levels of shock or vibration, the ibeoNEXT measurement core reliably obtains over 10,000 elements of distance information from each 3D measurement. It also generates a black-and-white image similar to that from a camera, which enables an even more reliable '4D' detection of the surroundings.

"We decided to use Ibeo's solid-state LiDAR technology because it is currently one of the most advanced 3D LiDAR measurement systems available in the world. It is an addition to our technology portfolio and enables us to offer, on top of our existing industrial applications, new, easy-to-integrate solutions in the field of autonomous and semi-autonomous driving for use in the industrial sector," says Dr. Kay Fürstenberg, senior vice-president for research and development at SICK AG.

Selected customers of SICK will have the opportunity of testing this new 3D solid-state LiDAR sensor as early as in 2021.

[www.sick.com](http://www.sick.com)

Signals are effectively transmitted with the latest satellites when equipped with the newest Miki Pulley BXR-LE brakes. They effectively control satellite dish positioning using less power over long periods of operation.

The Miki Pulley brake opens and allows for free rotation when the satellite dish is panning and tilting, and snaps closed when power is disengaged holding precise position. When the satellite dish is in position for long periods of time, the brake consumes no voltage.

The brake's internal compression springs hold the armature plate against the rotor disc, holding movement. When voltage is re-applied, the brake opens and allows for position control.

These Miki Pulley brakes also act as a safety device during dish movement. If an unexpected power interruption occurs, the brake will halt and hold movement to mitigate potential mechanical damage to the satellite system.

[www.mikipulley-us.com](http://www.mikipulley-us.com)

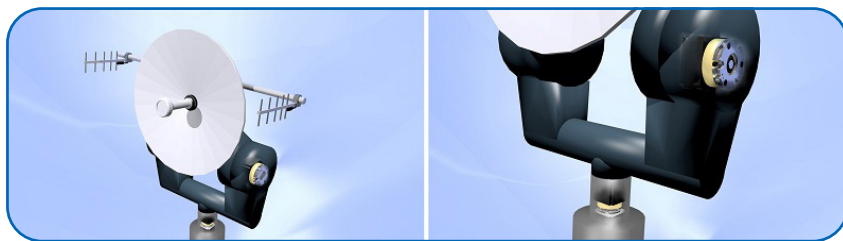

# Binder

## EXPANDS M12-A CONNECTOR PORTFOLIO

Binder USA, LP, has expanded its M12-A connector portfolio with two new rectangular flange connectors. Designed for today's advanced automation technology, the connectors provide new options for sensor and actuator applications.

The M12-A connectors include a stranded-wire version with 20mm or 26 mm rectangular housing, and a solder version with 20 mm housing. (The stranded-wire 26 mm version uses the same drilling template as the M16, allowing users to switch to M12 without changing the existing housing.) For simple and reliable installation,

binder used a two-part approach consisting of the housing and the contact holder, allowing the coding nose of the contact holder to be positioned in increments of 45°.

[www.binder-connector.us](http://www.binder-connector.us)

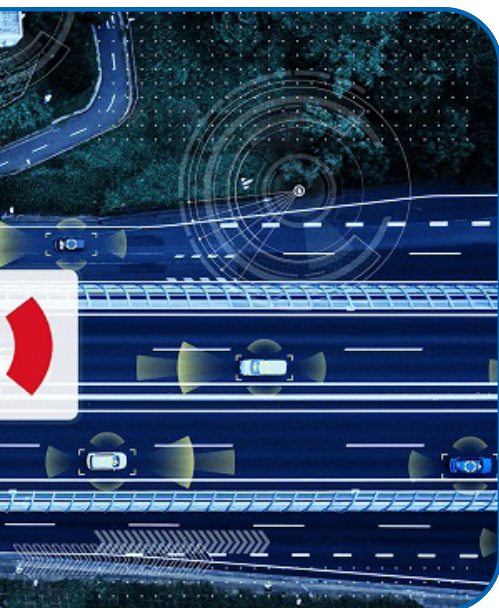

# Dana

## INTRODUCES HEAVY-DUTY DRIVETRAIN FOR ROUGH-TERRAIN CRANES

Dana Incorporated has introduced a new drivetrain for rough-terrain cranes with lift capacities from 83 to 110 tons (75 to 100 tonnes) and terminal tractors.

The Spicer 246 heavy-duty steer axle and Spicer C3300 remote torque converter are offered as part of a complete drivetrain solution for rough-terrain cranes that delivers premium

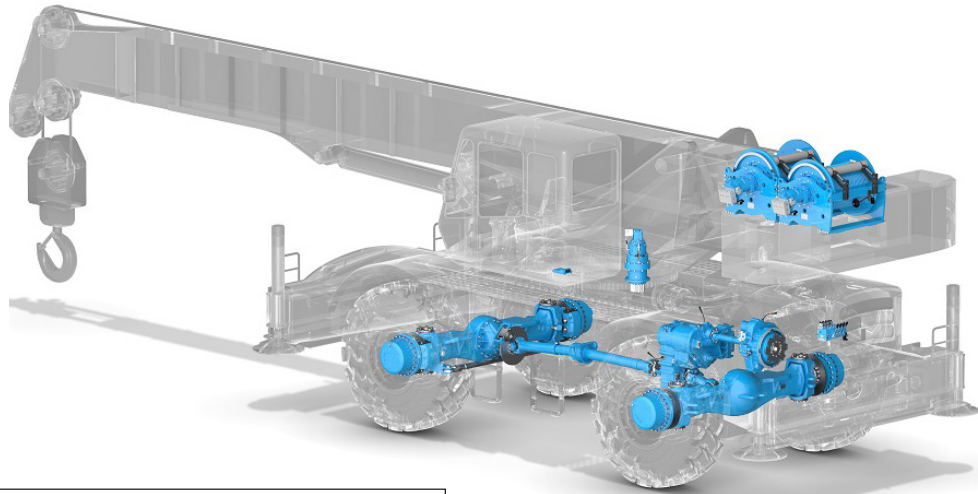

## YOUR BEST SOURCE FOR METRIC

### MOTORS, GEARBOXES & COOLANT PUMPS

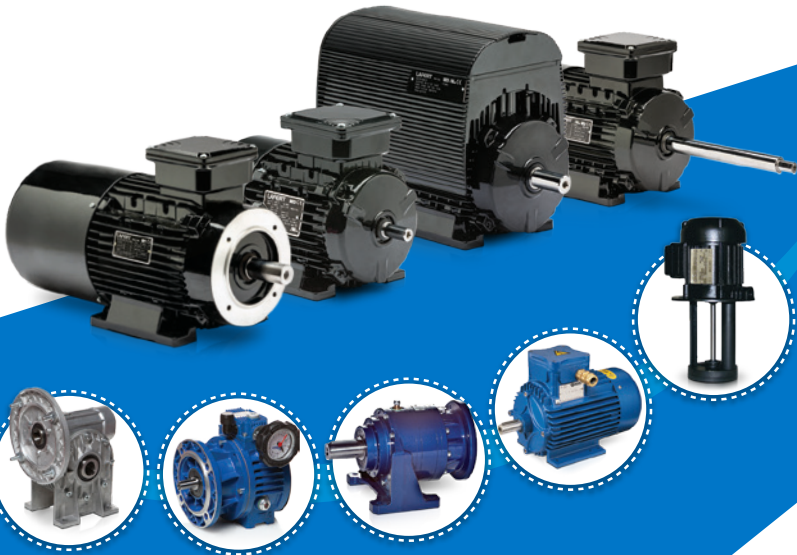

Toll Free: 1.800.661.6413 Fax: 1.905.629.2852  
www.lafertna.com Sales1@lafertna.com

Copyright Lafert North America 2017. All rights reserved.



performance through improved gradeability and travel speeds, higher efficiency in the field, increased productivity, and reduced operating costs.

“As the global construction market recovers, buyers are looking for high-performing vehicles that deliver exceptional productivity and efficiency,” said Aziz Aghili, president of Dana Off-Highway Drive and Motion Systems. “Dana’s large and growing capabilities for rough-terrain cranes enable us to anticipate market shifts and collaborate with original-equipment manufacturers to supply the drivetrain technologies that improve their competitiveness.”

#### New Heavy-Duty Spicer 246 Axle

Dana’s new heavy-duty Spicer 246 steer axle features a monolithic axle design and high integrity seals that deliver exceptional performance in the most severe working conditions. It features optimized steering geometries to minimize slippage, while the single universal joint design with outboard planetary gears provides high output torque and high-capacity braking with low drag at travel speeds.

Currently available for OEM field testing, the Spicer 246 axle can also be adapted for use with airport ground support vehicles, where it can be configured with optional wet brakes.

#### Efficient Spicer C3300 Remote Torque Converter

Dana has developed the new Spicer C3300 remote torque converter specifically for rough-terrain cranes. It is

optimized for engines up to 195 kW (260 hp) and can be packaged with Spicer remote transmissions. Dana is the only manufacturer worldwide that supplies a remote torque converter with three large pump drives for implements.

The Spicer C3300 remote torque converter is available with an optional lockup that improves efficiency while providing higher braking effort during downhill operation. It features new converter wheel sizes configured to optimize the performance of today's low-RPM engine designs.

Available now, the Spicer C3300 remote torque converter is already in use in terminal tractor applications, where it enables lower heights for fifth wheels.

#### Broad Portfolio of Drive and Motion Systems for Cranes

Dana has a large and growing selection of drive and motion technologies for manufacturers of tracked and wheeled cranes.

Earlier this year, Dana introduced a new series of Spicer Torque-Hub drives for crawler cranes and other large tracked vehicles. With torque ratings from 80,000 N-m up to 450,000 N-m, the new drives offer flexible packaging and gear ratios to meet manufacturer preferences for tracked and wheeled applications.

Also, Dana offers high-performance Brevini winches for cranes and other applications with lift capacities from 1.1 tons (990 kg) to 33 tons (30 tonnes).

Additionally, Dana supports the work functions of cranes with a wide selection of Brevini slew drives, hydraulic pumps and motors, and proportional directional valves.

[www.dana.com](http://www.dana.com)

## Goodyear Belts

PRODUCES BELTS FOR THE  
AUTOMOTIVE AND INDUSTRIAL  
MARKETS

Goodyear Belts, a licensee collaboration between Adventry and The Goodyear Tire & Rubber Company, has produced a line of power transmission belts targeting the demands of multiple markets globally. The line was launched on December 1, 2020 and offers belts for both industrial and transportation markets.

"We are thrilled to collaborate with such an iconic brand as Goodyear," said Tara Cevallos, CEO of Adventry. "Customers expect a great product and that is what we will deliver, along with our outstanding service. We truly strive to put the customer first in everything that we do."



"We are honored to be part of the incredible Goodyear heritage as we forge new relationships and product innovations," added entrepreneur Jorge Gomariz, chairman and founder of Adventry.

Goodyear Belts' new line features broad application coverage that meets or exceeds OEM specifications, refined engineering, and advanced manufacturing. Belt materials for both standard and specialty belts have been designed and tested to provide dependable and durable service.

[www.goodyearbelts.com](http://www.goodyearbelts.com)

Made in the USA  
Used Worldwide

OIL SHEAR  
MOTOR BRAKES



No Adjustment-Ever!



Maintenance Free!



FORCE CONTROL  
INDUSTRIES, INC

800-829-3244

[WWW.FORCECONTROL.COM](http://WWW.FORCECONTROL.COM)

# Forest City Gear

## ADDS ZEISS CMM TO QUALITY ASSURANCE DEPARTMENT

Forest City Gear has expanded the capabilities of its Quality Assurance Department with the addition of a Zeiss ACCURA Coordinate Measuring Machine.

The next-generation bridge-type Zeiss is Forest City Gear's fourth CNC inspection system, and is particularly well suited for very fast, complete analytical inspection of all types of high precision fine- and medium-pitch cylindrical gears. A variety of interchangeable Zeiss sensors provide a high degree of flexibility and faster calibration, approach and scanning for lead, involute, pitch, surface finish and other critical features across a wide size range.

The system also features a particularly compact and ergonomic design, making it ideal for Forest City Gear's fast-expanding, busy Quality Assurance room. The Zeiss ACCURA's bridge, for example, is made of steel and aluminum, making it extremely rigid, yet slim and compact. The reduced weight of the moving parts improves the dynamic rigidity and speed of the machine.

"The added capacity of the Zeiss ACCURA has now enabled Forest City Gear to move its existing Zeiss CONTURA CMM to meet the quality requirements of its new, stand-alone gear blanking facility," according to Forest City Gear Quality Assurance Lead, Amy Sovina. "The ACCURA couldn't have arrived at a better time, freeing up the CONTURA so we could put it in close proximity to the blanking operation and thus eliminate the travel time for inspection of blanks," says Sovina. "The Zeiss ACCURA checks all the metrology boxes. With quality and throughput requirements never higher in all the industries we serve, this system is the perfect addition."

[www.forestcitygear.com](http://www.forestcitygear.com)



aluminum worm speed reducers



Did you mean: **DieQua Corporation?**

## The search is over!

For quality aluminum worm gear speed reducers providing improved performance, high reliability and easy maintenance, look no further than DieQua.

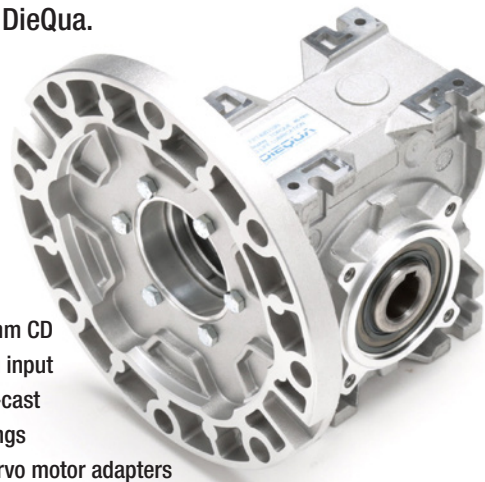

- 7 sizes, 28-110mm CD
- Flexible coupling input
- Light weight die-cast aluminum housings
- NEMA, IEC, or servo motor adapters

To finally find what you're looking for, check us out on the web, or give us a call.

[diequa.com/pte](http://diequa.com/pte) 800-276-1294  
**DIEQUA**  
 Corporation

# Altra Motion

PROVIDES STAINLESS STEEL POWERTRAINS FOR COASTAL MANUFACTURING

EDITED BY MATTHEW JASTER, SENIOR EDITOR

Hardly a day passes without a new FDA recall of some food product as the number of Americans falling ill from food contamination infections continues to rise.

While there are many causes of food poisoning, food processing equipment design plays a part. Motor and speed reducer drivetrains are found on all types of conveyors and equipment in food processing plants producing everything from beef and poultry to processed ready-to-eat products – in fact anything that people or their pets consume for nutrition or pleasure.

So, food processing equipment design, engineering and materials can play a big part in a plant's drive for food safety excellence. Anything that can be done to minimize contamination and reduce the costs of sanitizing these units is a worthy investment.

Many drivetrains on food processing equipment feature belts, chains and external gears enclosed in a cover for safety. All of these provide very attractive homes for all types of bacteria and other contaminants. One solution is to utilize hollow shaft reducers, which allow conveyor drive rollers to mount directly to the reducer, eliminating the need for these bacteria harboring components.

Cast iron and aluminum speed reducers and motors are widely used in the food processing industry. Their lower initial cost compared to stainless steel models makes them attractive. However, if the life cycle cost is considered, that picture can change drastically. If the use of stainless steel reducers and motors helps to avoid a single line shutdown due to coating failure that could cause a contamination risk, the cost of the lost production may pay for the stainless steel several times over. Because of this, many manufacturers are moving to all stainless steel speed reducers and drive motors.

Besides the consequences and cost of a coating failure

shutting down a production line, there is also the cost of keeping the line running. In one case, a poultry processor had laborers come in each weekend to paint and repaint gearboxes that had chipped paint or rust. This was done for each gear reducer at least once a year depending on the frequency of washdown. The cost of two of these re-coatings would have more than covered the cost differential between the gear reducers they were using and stainless steel gear reducers.

Coastal Manufacturing, a recognized industry leader, supplies custom designed equipment for food processing applications. According to Mark Hoffseth, a Coastal sales engineer, "Many of our customers face food safety audits that inspect every inch of their facilities and equipment, inside and out. Issues such as paint flaking or rust dripping in close proximity to a food contact area are unacceptable."

This equipment is typically used in production 16 to 20 hours/ day with the remaining hours used to sanitize with a combination of high-pressure water, acids, and sanitizing agents. Hoffseth says, "In our experience, no carbon steel products, regardless of how robust or cutting-edge the coating or plating, have ever held up in this environment over time. There is no easy way on this one, we have tried virtually every 'corrosion-resistant' surface available, and stainless steel is the only long-term solution."

For decades, the food processing and packaging industries have relied on Boston Gear 700 Series worm gear technology for long-lasting, high-quality performance. The Stainless Steel 700 Series takes that trusted performance to new levels by providing maximum corrosion resistance in the most challenging, caustic washdown environments.

Hoffseth explained that when so-called "corrosion resistant" products fail, it is often much more costly to repair



Boston Gear Stainless Steel 700 Series speed reducers were mounted to 3/4 hp stainless steel motors on conveyor drives in the system (photo courtesy of Coastal Manufacturing).

than with a stainless steel product. This is because, as they are failing, they are typically corroding and seizing onto the piece of equipment that they are mounted to. This can result in a far more difficult removal process, often damaging adjacent parts and components. Coastal has a 175-ton press in its shop, and there have been times when that press had to be used to remove seized, corroded parts. Typically, if that amount of force is required to remove a corroded part, there is often damage to other attached parts.

When asked about Coastal's customers' concerns regarding energy efficiency, cost of ownership, etc. Hoffseth said, "While these issues are important to everyone, I would say those are second-tier concerns. Food processing customers are mostly concerned with 'is it food safe'? and 'is this machine going to corrupt or harbor any product'? In most of the food and pharmaceutical areas that we work in, any equipment that contains corrosive parts is unacceptable. No question."

Coastal had used painted speed reducers from Boston Gear and other manufacturers for at least 20 years and decided to standardize on Boston's stainless steel units about 10 years ago. Hoffseth told us, "We have tried just about every brand of reducer - either due to customer specification or, often, because we are given other products to try out and there are some quality competitive reducers out there. But over the years, we have not found one that can beat the quality and availability of Boston Gear."

Hoffseth acknowledged that Coastal has a very large number of Boston Gear stainless steel units in the field. While all parts wear and eventually require rebuilding or replacement,



Boston Gear reducers have the lowest maintenance requirement of any component they use at Coastal Manufacturing (photo courtesy of Altra Motion).

he said that the stainless steel Boston Gear reducers have the lowest maintenance requirement of any component they use. "We install them and forget about them, typically never having to hear about them or work on them again. For us, the bottom line is Boston has a quality product and has never missed a delivery due date. That's the kind of company we want to work with, as that is the kind of company we are."

[www.altramotion.com](http://www.altramotion.com)  
[www.coastalmanufacturing.net](http://www.coastalmanufacturing.net)

## The Digital Experience with Regal Beloit

COMPANY DISCUSSES DIGITAL STRATEGY IN 2021

MATTHEW JASTER, SENIOR EDITOR

Regal Beloit Corporation recently announced it is now putting QR codes on Sealmaster and Browning mounted bearings products and bearing boxes including Browning, McGill, Rollway, Sealmaster and System Plast. Customers now have access to product specifications, including all critical



Perceptive Technologies install.

dimensions and features, and the Regal 2D and 3D CAD libraries, installation and maintenance instructions, and much more. PTE recently caught up with Dan Phillips, CMRP, technical director, monitoring and diagnostics, Regal Beloit, to discuss the company's digital strategies moving forward.

**PTE: Explain how Regal's QR codes make it easier to improve the customer experience in 2021.**

Phillips: Regal continues to look for ways to improve the customer experience. For instance, the company has added QR codes to products so that customers can easily scan them to access a mobile-friendly version of our website for additional product information. From the landing page, a user can receive direction on where to



Dan Phillips is the CMRP, technical director, monitoring and diagnostics, Regal Beloit.

find additional production information, how to register the bearing for an extended warranty, where to obtain maintenance and installation information, and learn where to make a purchase. Where possible, these QR codes are applied to Regal mounted bearing products and will soon be added to Regal gearing products. If not found directly on the product, these QR codes can also be found on our bearing boxes.

Regal has also launched the Perceptiv Tag-It program. Utilizing QR codes which plant personnel can apply to motors, speed reducers, bearings and other mechanical equipment, users can track assets, consolidate inventory, speed up the replacement order process, and upgrade to Regal remote monitoring and diagnostics services.



Regal bearing QR code example.

**PTE: What other digital tools and strategies is Regal implementing in the coming months?**

Phillips: In 2020, Regal merged several product/brand websites into [regalbeloit.com](http://regalbeloit.com), and we will continue to enhance the tools and functionalities on the site. We continue to work to improve our customer digital experience and our currently upgrading our eCommerce platform and selection tools to product a streamlined integrated mobile-friendly experience.

**PTE: How is smart manufacturing (IIoT, Industry 4.0, etc.) changing the way Regal conducts business? Describe the benefits of collecting more data from power transmission components via sensors, software etc.**

Phillips: At Regal, we continue to embrace the evolution to smart manufacturing, and our Perceptiv monitoring and diagnostics lead the way. Our team utilizes remote monitoring for some of our customers' critical equipment, providing real-time alerts and monthly performance reports. Fully integrating all of a facility's mechanical components is possible, and we work with our customers to evaluate the cost benefits and overall ROI of doing so. For some, having their critical equipment monitored is enough, while others integrate our components into their existing smart ecosystem.

**PTE: How has the pandemic altered your approach to digital solutions and strategies?**

Phillips: Because the Regal PTS group had already migrated its digital tools to the new [regalbeloit.com](http://regalbeloit.com) and continues to focus on improving the customer experience, we were ready for the remote interaction that the pandemic brought and the increased number of customers seeking information on our site. Less on-premises customer interaction in 2020 not only led to increased video conferencing, but also a strong focus on Perceptiv remote monitoring, which allows our team to help customers monitor the equipment in their facilities. We also expanded the Regal Training Academy.

**PTE: What are the greatest strengths of Regal's mobile apps? How will these apps evolve in the coming years?**

Phillips: The key focus of our mobile apps is putting information in the hands of our users via their ease of use. Our most popular and oldest app is the Browning HVAC Toolbox Technician App, and in 2020 we launched the Regal PT Mobile App. Both provide quick access to production, information, product interchanges and helpful tools. The Regal PT Mobile App allows users to register their Regal bearings for an extended warranty and then utilize its simple asset management function to schedule and track maintenance.

In 2021, we will be adding our gearing and component products to the Regal PT Mobile App. We will also expand the Perceptiv Mobile App, which allows users of our Tag-It program or remote monitoring to access information from their smartphone, laptop or desktop. In addition, we plan to continue to deploy mobile-friendly tools on the Regal website.

[regalbeloit.com](http://regalbeloit.com)

# Examining Functional Safety in Motion Control Applications

Matthew Jaster, Senior Editor

The International Society of Automation (ISA) defines functional safety as the detection of a potentially dangerous condition that depends on automatic protection or correction to prevent an unwanted consequence or reduce its severity. The automatic protection system is designed to respond appropriately to errors, hardware failures, and operational stressors. When every specified safety function is carried out and meets the set level of performance, functional safety is achieved. For years, many industrial organizations supported simple hardware and software solutions to protect its equipment as well as its workers. However, the increased complexity of components as well as the need for system integration continues to challenge machine designers today.

## A history of machine safety

A discussion on the history of machine safety starts with a good, firm barrier. Barriers that simply were put in place on the factory floor to isolate the operator from machine hazards. There were also emergency stop systems that halted the movement of the machine's operation. Power could be cutoff/shut-down immediately should the need occur.

Christopher Radley, senior product line manager, systems, at Kollmorgen believes these are all viable safety solutions, but they do have downsides as they can halt production, reduce productivity, damage in-process product, and may put the machine in an unpredictable state that leaves the operator exposed to the risk it was intended to address.

“Modern Functional Safety solutions can provide for the continued operation of the machine thus preserving productivity, avoiding in-process product damage and still offer

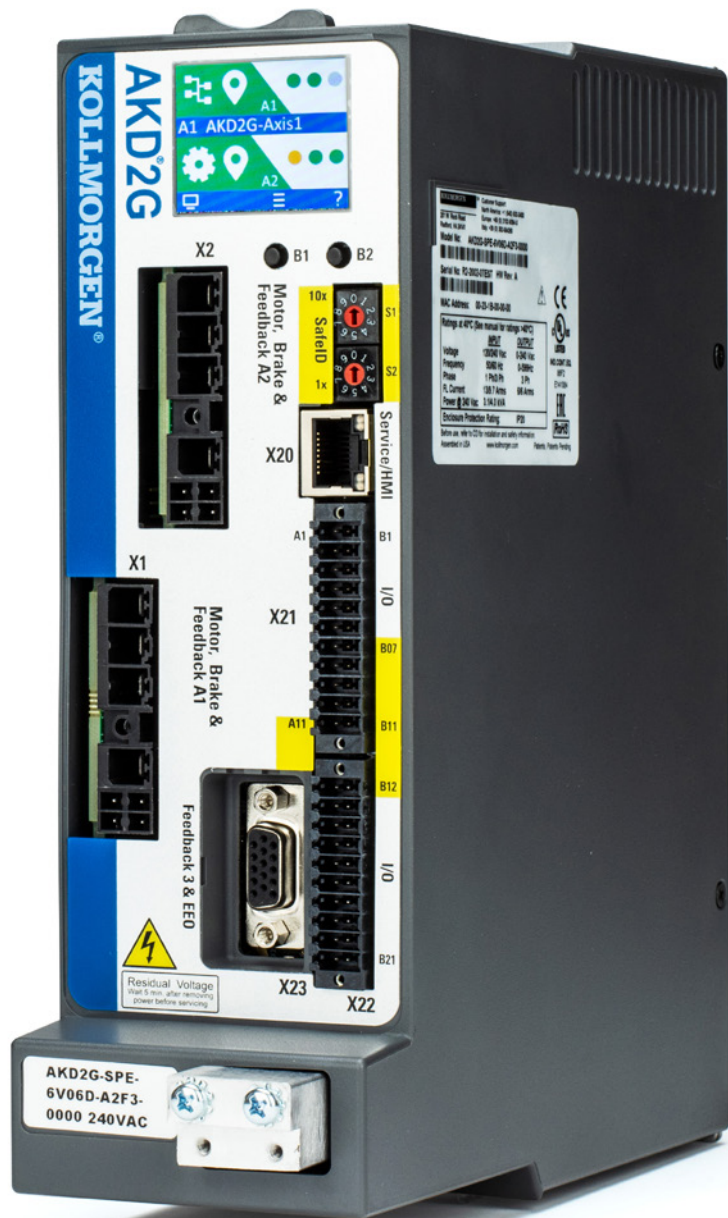

Kollmorgen's AKD2G Servo Drive with Built-in SafeMotion includes a full range of Safe motion options to suit virtually any functional safety requirement. These safety functions are 100% drive-resident, eliminating the need for external solutions that depend on complex integration between the controller, safe PLC, and drive (courtesy of Kollmorgen).



operator safety. These solutions retain the ability to provide emergency stopping when other safety measures are not adequate,” Radley said.

Europe has been a leader in machine safety and creating standardization around machine safety, according to Justin Hillukka, lead mechanical engineer of power transmission and custom products at Nexen.

“Industry standards like ISO 13849-1 have been around for a long time, but within the past 10 years, these standards have been revised and been applied more and more in the industry. Safety standards are utilized increasingly in machine design today,” Hillukka said.

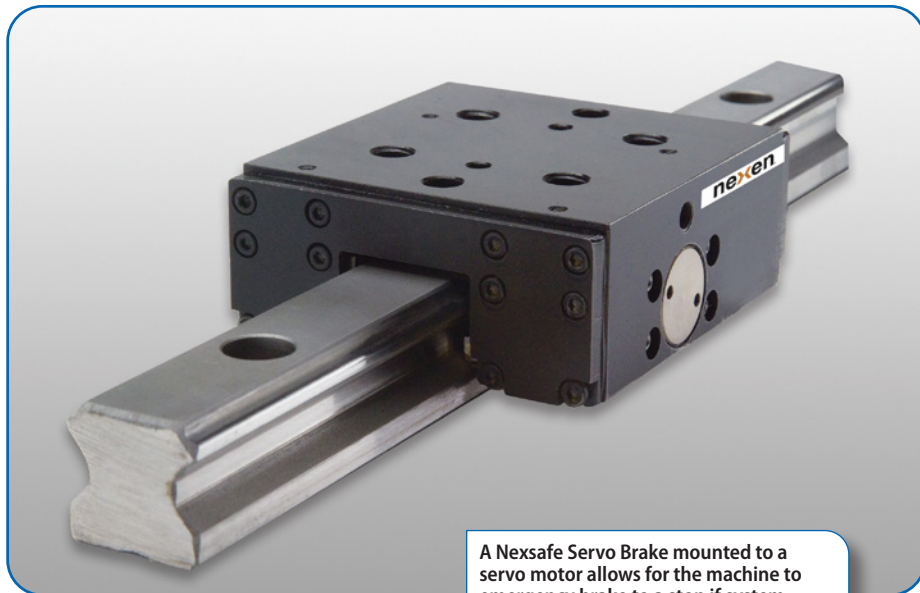

A Nexsafe Servo Brake mounted to a servo motor allows for the machine to emergency brake to a stop if system power is lost (courtesy of Nexen).

### Diagnostics, reliability and machine efficiency

What does functional safety mean to the power transmission market today and how can it improve diagnostics, reliability and machine efficiency?

Radley said that motion control with integrated safety functionality

can provide diagnostic information regarding which functionality (e.g. – Safe Stop, Safe Torque Off, etc.) was engaged and when. This lets machine builders and users consider whether something happened that affected the machine mechanics, the operator needs additional training, or there is



We answer EVERY CALL, EVERY TIME, within TWO RINGS.

*It's at the core of who we are.*



REVISION	REV	NAME	DATE
A	1	AKE	09/12/2019

NES Bearing Company has been providing American-made custom bearing products and services to customers in diverse industries for over 22 years.

-  NADCAP CHEMICAL PROCESSING
-  AS9100 CERTIFIED
-  ISO9001 CERTIFIED

NES Bearing Co., Inc.

nesbearings.com    sales@nesbearings.com    877-870-3200

-  Short lead times
-  Unique Materials
-  Custom or Made to Print



a material problem that is impacting machine performance.

“Today’s machines are designed to be more reliable than ever. But they still need to be properly maintained. Productivity demands can mean a desire to avoid machine shutdowns for routine maintenance, or at least delaying it. Machine designers can now take advantage of safety functions that let operation continue (function) while still being operated safely- (Functional Safety). Safety functions such as Safe Limited Speed, Safe Direction, and Safe Limited Position provide the ability to work with the functioning machine and maintain the needed operator safety,” Radley added.

Having fail safe, or default to safe position components in a machine is important for addressing risk of danger. “For example, having a Nexsafe Servo Brake mounted to a servo motor allows for the machine to emergency brake to a stop if system power is lost. Condition monitoring is also an important feature of safety systems. Having feedback loops in the controls systems allows the machine controller to know the state of the machine’s safety functions,” Hillukka said.

When performing a safety review on a design, Hillukka said it is required to review diagnostic coverage and reliability. The application risk/performance level will define and require the level of reliability and diagnostic coverage to be robust. A machine that is designed with safety in mind and a safety analysis performed according to standards like ISO 12100 and ISO 13849-1 will have sensor feedback for improved diagnostics, and more robust design for increased reliability.

“Depending upon rated durability of the components in a safety function, and how much risk is associated with the application, the safety function will need to allow for one or multiple faults in the machine before the safety function is compromised,” he added.

The most efficient machine—according to Radley—is the one that is running at top capacity as much of the time as possible. Avoiding unnecessary machine shutdowns when safety cages

are opened or light curtains breached, functionally safe systems can continue operating with specific protocols that provide operator safety. This can be particularly important when considering complex machines where a shutdown can entail significant time to reset and restart the machine.

#### Certifications and risk assessments

Any customer looking to take advantage of the previously discussed benefits of functional safety when implementing their motion system upgrade will need to perform a risk assessment.

“Risk assessment consists of a series

be part of your machine already meets a defined and certified level (such as SIL2 or PLd for example) makes the assessment teams task faster and more efficient while also improving confidence in the final determination. Having a stated SIL or PL for a given product is the data portion that helps with the risk assessment, however, it is the certification that tells the assessment team that the provided SIL or PL has been reviewed by a competent authority; it is not just the judgement of the supplier, Radley added.

Peace of mind also comes into play



Safety certifications, like the Functional Safety Certification Nexen received for its Nexsafe products, give an increased level of confidence to the machine builder (courtesy of Nexen).

of steps used to examine the hazards associated with machines. It consists of two stages, risk analysis and risk evaluation. The analysis and evaluation are used to make a risk estimation which is carried out for each identified hazard and hazardous situation. With this we can determine the required Safety Integrity Level (SIL) or Performance Level (PL) for the machine. This guides us as to the measures we will take, and the equipment we will use, to meet our required safety/performance level,” Radley said.

Additionally, safety certifications make the task of the risk assessment easier. Knowing that a product that will

for machine builders.

“Safety certifications, like the Functional Safety Certification Nexen received for its Nexsafe products, give an increased level of confidence to the machine builder. They know that the product is held to design, quality, and performance requirements specified by industry standards, and verified by an international recognized certification body. Nexsafe products are evaluated and confirmed by 3<sup>rd</sup> parted evaluation to meet all requirements for performance levels a thru e and categories B thru 4 per ISO 13849-1,” Hillukka said.

## Partnering on functional safety products and equipment

Beyond the obvious ability to supply the motion control products the machine builder needs, there are important considerations in the certification of the products *and* the equipment partners processes.

For the products, Radley said that the certifications need to be made by a competent, independent, third party such as TÜV.

“It is not enough that the equipment partner judges that they have designed the product to meet the requirement, the machine builder needs and wants that third party certification. It is also important that the equipment partner owns the safety certificate. It is less desirable to have a situation where the product is coming from another supplier and being labeled by the equipment partner. The lack of ownership of the safety certificate can create problems if the machine builder needs anything other than the standard product as changes may not be possible except by the safety certificate owner,” Radley said.

For the processes such as how the product is designed, built, and lifecycle managed Radley said there is also a need for certification. The equipment partner should have certification to IEC 61508-1 to 7, again from a competent, independent, third party such as TÜV. This is important for areas such as traceability for the products. This can be vital in case of an incident or a product recall.

“These certification requirements and processes are resource intensive, time consuming and expensive for equipment partners. Some equipment partners may want to gloss over their unwillingness or inability to make the investment. It is incumbent on the machine builder to ask the hard questions of their candidate partners- show me the certifications for the products, I need to confirm you are the certificate owner, show me your process certification, I’d like to review your process certification. In effect, asking ‘Are you certified by a competent,

independent, third party?’ and I want the proof because I’m going to use that in my risk assessment process,” Radley continued.

## Automation & the Factory of the Future

Demand for new safety functionality in response to the need for greater automation that maintains or enhances operator safety will increase in the coming years.

“The more we want collaborative work environments with machines and humans directly interacting the more we will demand those work environments be safe and efficient,” Radley said.

Improvements in electronics, and software architecture coupled with reductions in their costs will push more and more functionality to be integrated in the elements the machine must have, such as the motion control, rather than having to add additional hardware to the system.

“When we do need to expand beyond the core hardware the desire will be for standardized network-based solutions such as FailSafe over EtherCAT (FSOE) rather than extensive hardwired approaches, saving time, effort, and cost while making systems more reliable, easier to maintain, and easier to troubleshoot,” Radley said.

Kollmorgen offers a variety of control, drive and motor solutions that support functional safety from simple hardwired Safe Torque Off (STO) to complex implementations that need to bring together more advanced safety functions like Safe Stop, Safe Brake Control and even Safe Dynamic Braking. “These can require careful planning with our OEM machine builders to ensure that our portion works seamlessly with other hardware on the machine. When implementing functions like Safe Limited Speed or Safe Direction it’s important to work closely with these customers to know what their objective is for the function in relation to the machine operation,” he added.

Nexen’s approach has been to be aware how functional safety standards

and industry requirements are changing. “Based on these changes over the past few years, Nexen has shifted our focus to provide more safety focused components for machine builders. Nexen is committed to supporting our Nexsafe Functional Safety Certified components and furthering this portfolio of products to support applications outside of the scope of the rail brake, rod lock, and servo brake applications,” said Hillukka.

In the future, sensor feedback requirements for safety and for Industry 4.0 will become the standard. “Especially as factories become more automated,” said Hillukka. “The need for monitoring and diagnosing problems thru internal machine trouble shooting will keep increasing in value.”

All of these safety capabilities come back to making informative design decisions from the very beginning of a machine build.

“It is important to take a holistic view of functional safety beyond the products themselves,” Radley added. “The certification for the products, along with the certification for the design, manufacture, and lifecycle management tests the strength of an organization and builds the process muscle required for the customer’s success.” **PTE**

[www.isa.org](http://www.isa.org)  
[www.kollmorgen.com](http://www.kollmorgen.com)  
[www.nexengroup.com](http://www.nexengroup.com)



# Software for Gearbox Development

## The Influence of Bevel Pinion Retractability on Casing Design

Birgit Hutschenreiter, FVA GmbH

**The FVA-Workbench is a manufacturer-neutral tool for the simulation and calculation of transmission systems.**

As product development cycles become shorter, powerful modeling approaches and calculation algorithms become increasingly important. The predominantly analytical approaches in the FVA-Workbench deliver fast and reliable solutions to all important issues related to drive technology. For bodies that cannot be well described analytically, the results are supplemented by numerical methods. The intuitive modeling techniques in the FVA-Workbench guarantee consistent, valid, and manufacturable gears every time.

The calculations are developed, analyzed, and validated in research projects by Forschungsvereinigung Antriebstechnik e.V. (FVA, the German Research Association for Drive Technology). Through membership fees and public funding, the FVA is able to organize 14 million euros annually in research projects at leading German universities, chairs, and research. The FVA-Workbench serves as a platform to make this knowledge accessible to all engineers.

Load-free tooth contact simulation – the foundation for complex bevel gear calculations in the FVA-Workbench

Precise load carrying capacity calculations can be used to determine the stress, load carrying capacity, damage sums, and other characteristics of bevel gear stages. The load-free contact simulation, in particular, has the potential to significantly influence the design process.

The starting point for every calculation is the exact surface of bevel and hypoid gears and their position relative to each other. The descriptions of the tooth flank and tooth root are generated in a manufacturing simulation,

taking machine settings and manufacturing deviations into account. Compensation areas are used to transform this discrete point cloud into a gapless mathematical description of the tooth surface.

The load-free tooth contact simulation is the core component of the rolling contact simulation, and can efficiently determine the key parameters of the gear. Relevant evaluation criteria include: the ease-off, the load-free working variation, the load-free contact pattern, determination of the backlash, and the axial retractability of the pinion (FVA Research Project 456 II "BECAL - Backlash and Retractability," TU Dresden IMM, Prof. Dr. Schlecht).

The **circumferential backlash** is chosen based on the gear parameters, production quality, and the relative position deviations to be expected under load. This prevents meshing interference and gear jamming. Too little backlash can lead to jamming due to relative position deviations under load, too much can lead to increased

noise and reduced load capacity.

In addition to the microgeometry, the mounting position, relative position deviations under load, and specified pitch deviations of the working and trailing flanks are considered when calculating the backlash.

In practice, bevel gears always include flank modifications. Therefore, the backlash is not constant when considered across the meshing positions (see Figure 1). The difference between the minimum and maximum backlash is caused by superposition of the working variations in drive and coast operation. The theoretical foundation for the backlash calculations was developed and implemented in FVA Research Project 223/XVIII ("BECAL - Operating Clearance," TU Dresden IMM, Prof. Dr. Schlecht). The influences related to backlash calculation are being reassessed in ongoing research projects in order to better reflect the actual conditions under load.

Evaluation of the retractability of the pinion is another application for the

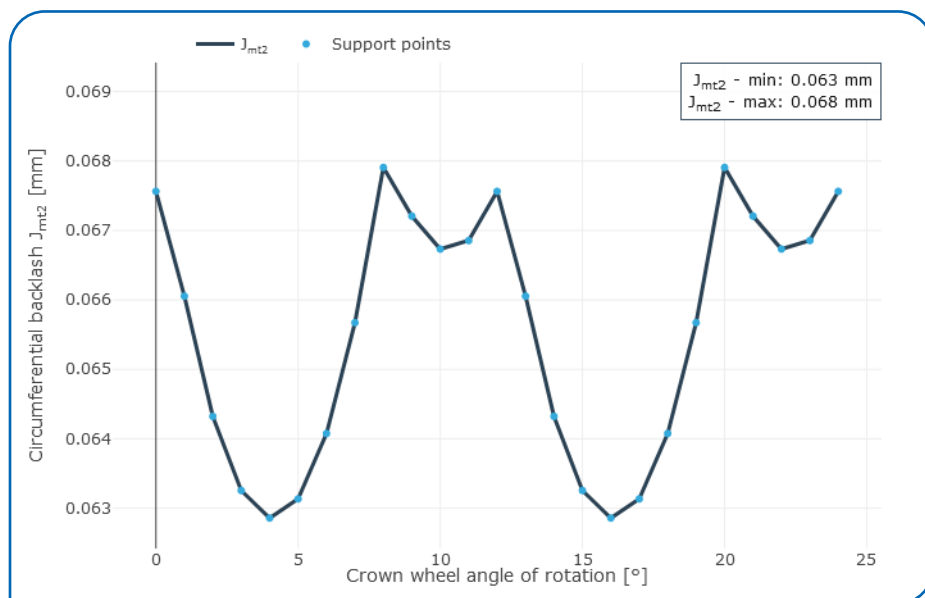

Figure 1 Representation of the average circumferential backlash over the angle of rotation of the crown wheel for 2 pitches in transverse section (graph taken from FVA-Workbench report).

circumferential backlash calculation. A pinion is **retractable** if it can be rotated out of the mesh and the pinion only moves along the gear axis. The relative position of the axis of the pinion only changes in the axial direction out of the mesh as a result. Retractability refers to both the mounting and disassembly procedures. This has an enormous influence, especially on the design of the casing. The question of whether or not the bevel pinion is axially retractable significantly influences the mounting and disassembly processes.

Retractability is calculated from the backlash. Therefore, the exact tooth form, including microgeometry and manufacturing deviations, is also taken into account here. The cutter head radius  $r_{c0}$  has the greatest influence on the retractability, as it determines the curvature of the flank in the longitudinal direction. This should be the very first thing to be adjusted in order to optimize the retractability. A larger cutter head radius increases the retractability, but is limited by economic considerations and a change in the displacement behavior, and therefore cannot simply be increased as desired.

In the FVA-Workbench, the minimum and maximum backlash over the axial displacement of the pinion are graphically represented as a result of the retractability calculation. The following three cases can occur:

- **Retractability:** The curves of the minimum and maximum backlash increase monotonously. The lowest values are located at the coordinate origin.
- **Conditional retractability:** The lowest value of the minimum backlash is negative and the lowest value of the maximum backlash is positive. This means

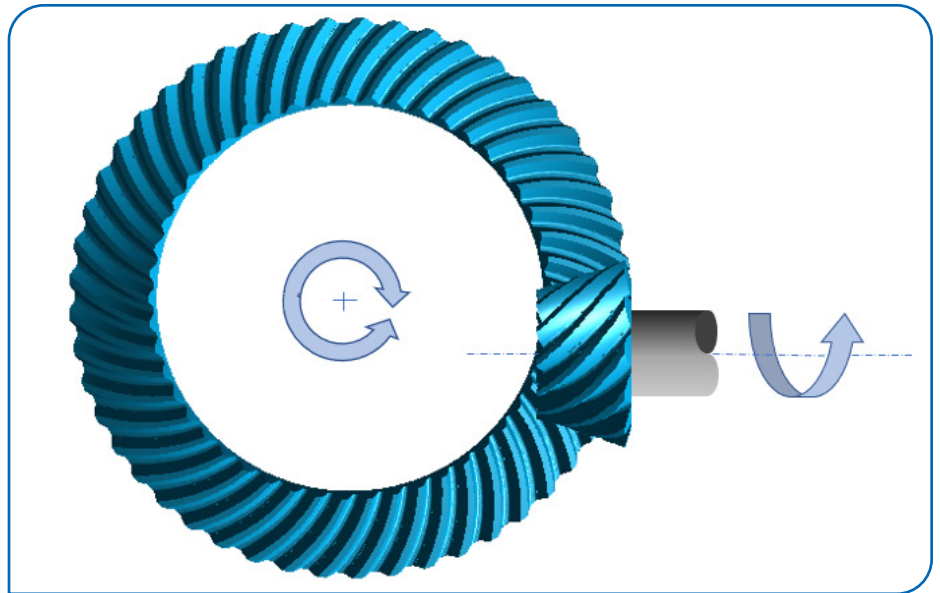

Figure 2 A pinion is retractable if can be rotated out of the mesh along the pinion axis.

that there are meshing positions in the corresponding axial pinion positions in which the pinion and the crown wheel do not interpenetrate. Jamming while rotating the pinion and crown wheel toward each other can only be avoided under ideal conditions. Retractability cannot be assumed without additional testing.

- **No retractability:** The minimum values are negative. This means that meshing interpenetration is calculated for all axial pinion positions with negative minimum and maximum backlashes. The gearing jams and the pinion cannot be moved axially.

The retractability results for a bevel gear with the basic geometry described in Table 1 are summarized in Figure 3.

Without retractability, the pinion can be mounted by placing it into the mesh in the axial direction of the crown wheel axis, or by lowering the crown wheel if the design allows (axial displacement of the crown wheel out of the mesh). Axial retractability of the pinion can be achieved under these conditions (see Figure 3). In this case,

it should be verified that the value specified for the lowering of the crown wheel is sufficient for the retractability calculation.

Calculation of retractability in the design phase makes it possible to draw important conclusions on the design as well as the requirements for the gearbox environment (casing). If the pinion is not retractable in the initial bevel gear design, the design can be adapted until retractability is achieved. The FVA-Workbench can quickly and efficiently calculate the effectiveness of these changes.

### About FVA GmbH:

FVA GmbH is a joint venture of VDMA (Verband Deutscher Maschinen- und Anlagenbau, the Mechanical Engineering Industry Association) and FVA e.V. (Research Association for Drive Technology). Founded in 2010, FVA GmbH works hand-in-hand with top-level German research institutions and leading companies from the drive technology industry toward the active

Table 1 Basic geometry of the bevel gear being examined		
Basic geometry parameters	Pinion	Crown wheel
Number of teeth	15	43
Normal module	3.18 mm	
Shaft angle	90°	
Hypoid offset	0.0 mm	
Face width	35 mm	35 mm
Average pinion cone distance	88.41 mm	88.41 mm
Average helix angle	35°	-35°

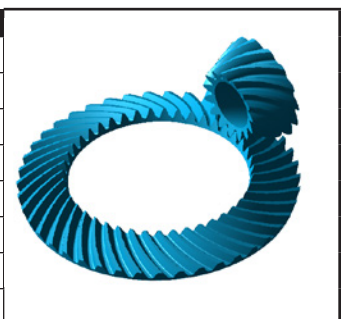

transfer of knowledge gained from FVA research projects into industrial practice. The company's core competencies are the development of calculation and simulation software for drive technology, preparation and transformation of established legacy code structures into modern software architectures, professional service and support, and technical seminars and conferences. **PTE**

[www.fva-service.de](http://www.fva-service.de)

**Birgit Hutschenreiter,**  
FVA GmbH.



For Related Articles Search

gear design

at [www.powertransmission.com](http://www.powertransmission.com)

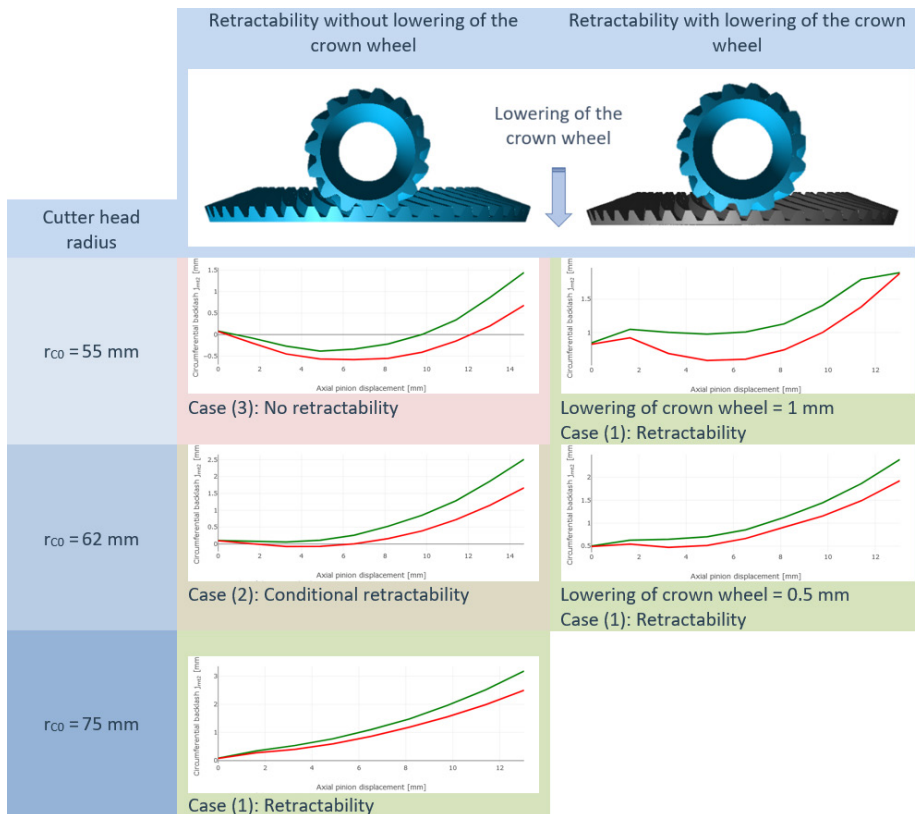

Figure 3 Influence of the cutter head radius and lowering of the crown wheel on retractability.

# Power Transmission Engineering online!

IT'S LIKE YOUR OWN **PROFESSIONAL SUPERPOWER.**

stronger, faster and smarter than your average website, [www.powertransmission.com](http://www.powertransmission.com) offers everything you need to supercharge your engineering-oriented organization.

- Complete archive of articles on engineered components
- Directory of suppliers of gears, bearings, motors and other mechanical power transmission components
- Product and Industry News updated daily
- Exclusive online content in our e-mail newsletters
- The Bearings Blog
- Calendar of upcoming events
- Comprehensive search feature helps you find what you're looking for — *faster than a speeding bullet!*

[www.powertransmission.com](http://www.powertransmission.com)



**REGISTRATION  
OPENS MAY 1**

Now accepting hotel reservations.



**MOTION+POWER**  
TECHNOLOGY EXPO

**GEAR**  
**ELECTRIC**  
**FLUID POWER**

 **MOVING THE FUTURE.**

At MPT Expo, you'll see the full range of power transmission solutions, including hybrid solutions, utilizing mechanical power transmission, pneumatics, hydraulics, electric motors, and drives.

**SEPTEMBER 14-16, 2021**

AMERICA'S CENTER CONVENTION COMPLEX  
ST. LOUIS, MO

**Your safety is our priority.  
Regular updates posted at  
[MotionPowerExpo.com](http://MotionPowerExpo.com).**

Formerly Gear Expo Owned by



American  
Gear Manufacturers  
Association

# Mechatronic Subassemblies for Factory Automation

## Three trends to consider in 2021

Richard Vaughn, Automation Engineering Manager  
Richard Hansen, Senior Automation Engineer  
Bosch Rexroth Corp.

Fully integrated mechatronic subassemblies provide versatile and cost-effective solutions for factory automation applications. These pre-engineered mechatronic subassemblies are an essential component of today's high-speed and high-precision automation. Cartesian robots provide simple, robust and readily available multi-axis motion. Utilizing complete solutions, including linear components, servo motors, controls and sensors, makes it easier and faster for machine builders to bring the overall complex manufacturing system for demanding industries to market.

### Industry Trends in Machine Building

Constant pressure to improve both the cost-efficiency and the flexibility of the machines they build and use is driving increasing numbers of original equipment manufacturers (OEMs) and end-users to seek suppliers that can deliver integrated solutions versus committing their own resources to engineer and develop solutions. There are several key industry factors driving this movement.

- OEMs and end-users are focusing on core competencies: OEMs that build highly specialized machines realize the value of concentrating engineering resources on optimizing the performance of their machines' core functions. This makes it more attractive to outsource the creation of the machines' subsidiary motion functions to suppliers with proven expertise in these areas.
- Integration of control and mechanical functions: Machine builders and users alike are recognizing the benefits of approaching motion technologies as a single discipline. Adopting a method that combines multiple



Integrating a complete, well-engineered and intelligent solution that includes linear components and electric motors, controls and sensors makes it easier for machine builders to quickly build complex manufacturing systems for demanding industries ranging from food processing and packaging to semiconductor fabs. All photos courtesy of Bosch Rexroth.



technologies into complete subassembly solutions delivers economies of scale and design advantages.

- **Next-generation engineers:** Recent engineering graduates may be more inclined towards the use of integrated subassemblies compared to their predecessors due to engineering roles becoming more demanding in ever-increasingly lean-running companies.
- **Retrofitting existing production lines:** To meet the demand for customization and Industry 4.0 capabilities, manufacturers are retrofitting existing production lines. Using subassemblies equipped with open engineering control interfaces that can communicate with existing systems, regardless of programming language, makes it easier to facilitate these transitions.
- **Supplier consolidation:** Rather than relying on multitudes of suppliers, engineering staff and purchasing agents are seeking one source to engineer, integrate and supply as many components as possible into complete solutions.
- **Globalization of the end-user:** Global supply chain dispersal causes many manufacturers to require OEMs to support their products, from engineering through delivery and long-term maintenance, in locations throughout the globe.

### Applications for Subassemblies

In many applications, ready-to-use subassemblies built from standard equipment can readily meet customer requirements; in some instances, however, these subassemblies may require custom engineering to address special or unique specifications. With either scenario, there are advantages to working with a single-source supplier that can provide a more complete solution.

Ready-to-use systems with standard

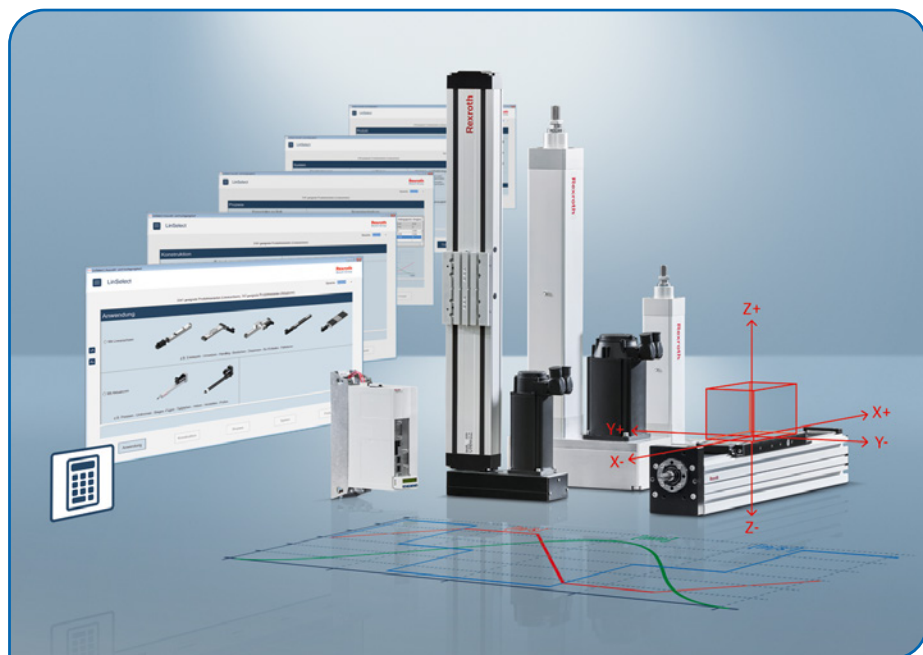

Integrating a complete, well-engineered and intelligent solution that includes linear components and electric motors, controls and sensors makes it easier for machine builders to quickly build complex manufacturing systems for demanding industries ranging from food processing and packaging to semiconductor fabs.

linear modules and preconfigured control function blocks can be suitable for applications such as material transport between production lines. Common uses include pick-and-place machines, automated storage and retrieval, palletizing and tool handling for machining operations.

For more intricate and unique projects, custom-engineered subassemblies solve challenges associated with precision motion profiles, tooling accuracy and vibration elimination in complex manufacturing systems. For example, in the semiconductor manufacturing industry, Bosch Rexroth developed a wafer-lift subassembly designed for ultra-smooth motion when transitioning delicate semiconductor wafers between process points. Our engineers created a cost-optimized subassembly design using Rexroth ball screws and servo motors that integrated into the existing machine envelope. This subassembly solution reliably exceeded the five million cycles target while providing a 30% cost reduction versus an OEM in-house version.

In another application, our team designed a linear transport subassembly to move laboratory samples within a medical diagnostic tool. This compact subassembly required precise

engineering to fit within the existing machine envelope. The result was a cost-effective design which enabled the machine builder to concentrate valuable engineering resources on its core competencies.

### Key Factors in Subassembly Selection

Efficiency, reliability and long-term maintainability depend on component performance and supplier engineering competency. Selecting the right supplier calls for a full understanding of that company's capabilities, including the requisite portfolio of motion products, as well as the supplier's engineering resources, experience and manufacturing capabilities.

A supplier's strength in motion subassemblies represents more than just proven products integrated into thousands of installations worldwide. The coupling of premium products with advanced engineering expertise is critical to success. This engineering expertise includes a thorough knowledge of design requirements for use in sizing, selecting and integrating appropriate motion components joined with extensive experience in programming motion control systems.

To take full advantage of the versatility and cost-savings that subassemblies

# FORGING AHEAD OF THE PACK

MADE IN THE  
**USA**

**Fast.  
No Fine Print.  
No Premium.**

At McInnes Rolled Rings, we provide quality products, shipped fast. And we partner that with exceptional customer service to forge the perfect partnership with our customers.

**McINNES  
ROLLED RINGS**

**1.877.736.4409**

[www.McInnesRolledRings.com](http://www.McInnesRolledRings.com)

offer, it is important to consider certain design factors when working with a supplier.

One should always look at the mechanics first before forging ahead with the electrical and controls design. Trying to specify electrical components before the mechanics can lead to wasted time and potential rework. Parameters such as motor inertia and torque are influenced by the system's mechanical components. Factors for

load, orientation, speed, travel, precision, operating environment and duty cycle are most critical. Deviating from this process can result in the selection of unnecessarily large or expensive mechanical systems. For example, if the OEM or end-user forces a design to accommodate a specific motor without considering these criteria, larger mechanical components may be required to handle the motor torque or inertia than those actually needed for



Machine builders and end-users alike are recognizing the benefits of approaching motion control and linear motion technologies as a single discipline. Adopting a method that combines both technologies into complete subassembly solutions delivers economies of scale and design advantages.

the application.

One should also consider the motion controller and drives so they align with the characteristics of a specific linear module. The motion controller and drive parameters need to have correct, safe torque and end-of-stroke limits programmed to ensure that the linear module does not overshoot its limits and crash. Likewise, if a ball screw-driven module can achieve 0.010 mm in position repeatability, the encoder must meet or exceed this specification; otherwise, you will not be able to take full advantage of the ball screw precision.

An oversized motor could potentially exceed the module's torque limit, causing mechanical failure or inertia and settling issues. Unpredictable settling can be a particular problem in precision applications. Excessive motor inertia compared to the module may result in difficulty achieving the desired position, resulting in longer overall cycle times than required. Particularly in precise applications, it is imperative to size the mechanical and electrical components together to achieve an ideal one-to-one inertia ratio or as close as possible to this ratio. Minimum power consumption is also important for customers who are looking to reduce the overall environmental impact.

Similarly, selecting linear modules based on inaccurately overestimated performance criteria can lead to a system that is more complex and expensive than necessary. The ideal supplier will offer a range of appropriate mechanical drive options to meet the performance criteria, including ball screw, toothed belt or linear motor drives, for example. It is also important to ensure that the supplier's electrical and mechanical engineers clearly understand and communicate all the established parameters for the performance of each linear module.

### Working with Suppliers

To ensure that motion subassemblies satisfy the given project requirements, it is critical to work with a supplier that can test the operation with state-of-the-art production equipment and

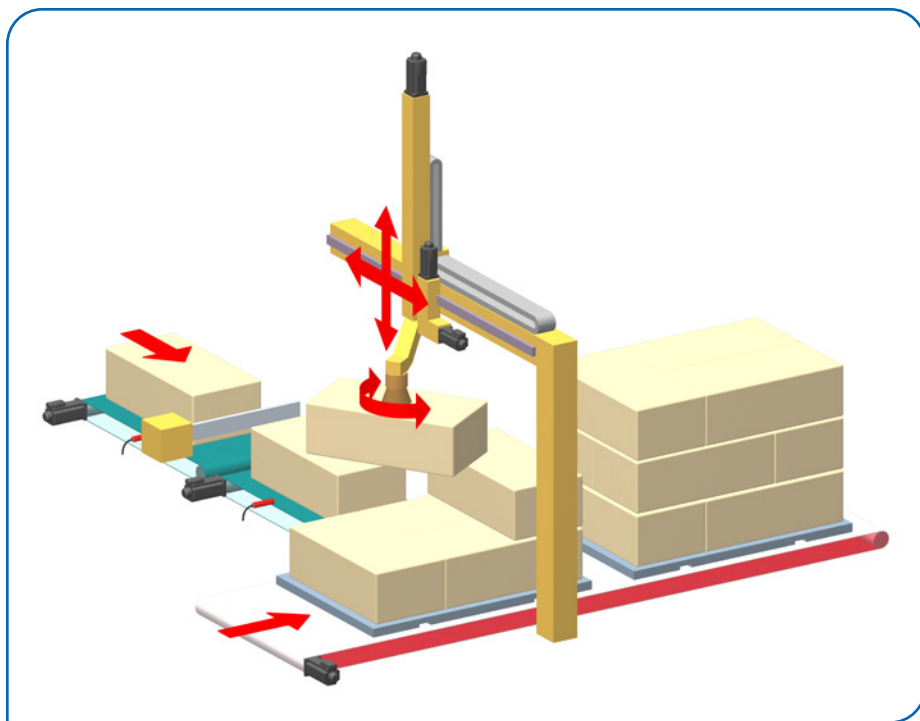

Ready-to-use systems with standard linear modules and preconfigured control function blocks based on common applications can be suitable for applications such as material transport between different production lines.

quality processes. Key capabilities to evaluate here include:

- Product qualification plans that feature documented controls related to manufacturing
- Standardized Supplier Quality Assessment (SSQA) programs that include complete enterprise audits
- Reliability testing
- Precision measurement capabilities, including laser inspection of finished subassemblies if needed
- Major industry certifications, including ISO 9001, ISO 14001 and ISO 18001

Finally, besides product portfolio and manufacturing capabilities, it is also important to consider the supplier's global and local resources for collaborative engineering, project management and support. Meeting these important criteria is crucial for a sub-assembly supplier looking to join forces with customers in the development of mechatronic solutions that satisfy performance, manufacturing and cost-savings requirements. **PTE**

[www.BoschRexroth-US.com](http://www.BoschRexroth-US.com)

For Related Articles Search

automation

at [www.powertransmission.com](http://www.powertransmission.com)

# Stock Drive Products/ Sterling Instrument

## Precision CNC Machined Components

**Stock Drive Products/Sterling Instrument (SDP/SI)** creates precision gears, superior mechanical components, and custom engineered solutions for the most highly-regarded names in the aerospace, precision medical, and defense industries. Our in-house design, precision manufacturing, and assembly capabilities let us meet the critical tolerances and functionality needs our customers require.

As a full service provider, OEMs around the world rely on us for innovative solutions. Providing engineering support from beginning to end, we offer valuable insights during the early design stage of a project. Drawing from 70 years of problem solving capabilities and manufacturing experience, customers benefit from our expertise, resulting in design improvements and optimum manufacturability.

SDP/SI specializes in miniature to small mechanical components as well as subassemblies for integration into larger systems fully supporting our customers from prototype to high-volume production. Our small power transmission and motion control components can be found in thousands of applications in a wide assortment of industries.

Partnering with medical device manufacturers we deliver the high-quality components required for precision medical applications including surgical robotics, blood analyzers, drug delivery systems, and COVID testing equipment.

As a manufacturer in the aerospace gearbox industry, our custom gearbox assemblies provide the means to position wings, open doors, fuel control, instrumentation, loading and steering mechanisms. A wide variety of SDP/SI precision gears and custom gear assemblies can be found on components, assemblies, and subassemblies around

Standard over 87 a preference and the



- Timing Belts and Pulleys
- Precision Gears
- Precision Gearboxes
- Motors
- Gearheads
- Motion Control Products
- Speed Reducers / Increases
- Bearings
- Couplings
- Clutches and Brakes
- Hardware

SDP/SI provides solutions that fit your needs; mechanical, electromechanical, molded, machined, assembly, our engineers look forward to working with you!

### Certifications

ISO 9001:2015 + AS9100D Certified  
 ITAR Compliant – DDTC Registered  
 RoHS & REACH Compliant  
 DFARS compliant

# SDP/SI

STOCK DRIVE PRODUCTS/STERLING INSTRUMENT

### FOR MORE INFORMATION

250 Duffy Avenue, Hicksville, New York 11801

Phone: 516-328-3300

Toll Free: 800-819-8900

Fax: 516-326-8827

Email: [sdp-sisupport@sdp-si.com](mailto:sdp-sisupport@sdp-si.com)

[www.sdp-si.com](http://www.sdp-si.com)

# Andantex USA

## Powering Industry Worldwide

### RACK & PINION DEDICATED REDUCERS

Only a handful of manufacturers in the world are able to offer planetary reducers with extremely high precision achieving less than 1 arc-minute of backlash without mechanical preload. Out of this already-small group of manufacturers, only Redex-Andantex makes a family of high precision planetary reducers specifically designed for use with racks on linear axes, ring gears on rotary axes for machine tools, and automation equipment.

#### What is a rack & pinion dedicated reducer?

A rack and pinion dedicated reducer has a pinion as the output, and is optimized to position within microns while moving large loads and providing smooth motion for in process operations (i.e. machining parts, carbon fiber placement, robot axes etc.). The parameters that the design of the reducer must meet in order to achieve this performance are:

- Extremely high compound stiffness
- Minimum transmission error for smooth operation and low noise during high speed operation
- Compact footprint to easily integrate into machine designs
- High efficiency
- Minimum to ZERO-BACKLASH

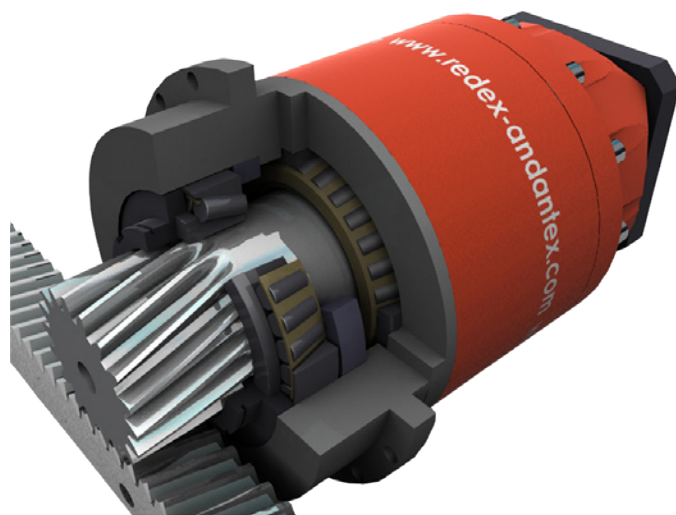
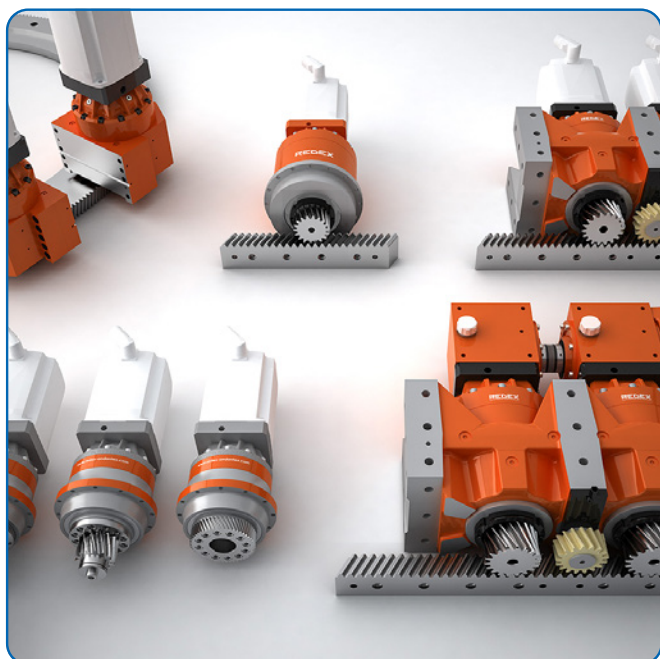

### RP Range Output Pinion Design

The Redex-Andantex family of rack and pinion dedicated reducers achieves all of these objectives through unique design. The most important parameter in a rack and pinion drive is stiffness to provide excellent position repeatability during high accelerations and avoid resonant frequencies that make servo-control difficult. So, we have optimized the output stiffness to minimize deflection in all planes (radial, torsional, and axial) through a patented integration of the output pinion onto the output shaft.

The pinion pitch diameter is kept small and is perfectly matched to the torsional stiffness of the planetary gear train, thereby ensuring high torsional stiffness. Large, preloaded tapered roller bearings go over the pinion and provide the radial and axial stiffness of the system. This compound stiffness minimizes the linear deflection of the drive system.

Redex-Andantex RP products meet all of the requirements of a high-performance rack and pinion or rotary axis drive system. There is no other solution on the market that incorporates all of this performance in one range of dedicated reducers. Please contact Andantex for application solutions.

## ANDANTEXX USA Inc.

#### FOR MORE INFORMATION

1705 Valley Road, Ocean Township, New Jersey 07712

Phone: 800-713-6170 (732-493-2812))

Fax: 732-493-2949

Email: [info@andantex.com](mailto:info@andantex.com)

[www.andantex.com](http://www.andantex.com)

# Zero-Max, Inc.

## Innovative Motion Control Products

For nearly 70-years, **Zero-Max, Inc.** has created innovative motion and control technologies such as servo-rated shaft couplings, adjustable speed drives and keyless shaft bushings. We have an international reputation for innovative designs that provide the quality, durability and performance required for demanding applications. Our high precision engineered solutions are used in automation machines world-wide including packaging, printing, CNC machine tools, wind turbines, forestry and construction equipment, servo motor driven machines, and more.

With strategic distribution points located throughout the world, Zero-Max can deliver your motion control solution. Whether you need a SAE mount or non-SAE mount overhung load adaptor or a counter-rotating gearbox, our team of application specialists can engineer a solution to meet your motion control requirements.



# ZERO-MAX

### FOR MORE INFORMATION

13200 Sixth Avenue North Plymouth, MN 55441-5509

Phone: 763-546-4300

[www.zero-max.com](http://www.zero-max.com)

# Power Transmission Engineering

## Free Knowledge Served Daily

For even more great information on automation, including technical articles, features and insight from the leading manufacturers, case studies and application examples, visit the *Power Transmission Engineering* archive.

[www.powertransmission.com/subjects/automation](http://www.powertransmission.com/subjects/automation)

But don't stop there! Just type what you're looking for into our search box at the top-right of any page, and you'll find just as much great information from our archives on virtually any topic related to mechanical power transmission and motion control, whether it's gears, bearings, motors, clutches, chain, gearboxes and more.

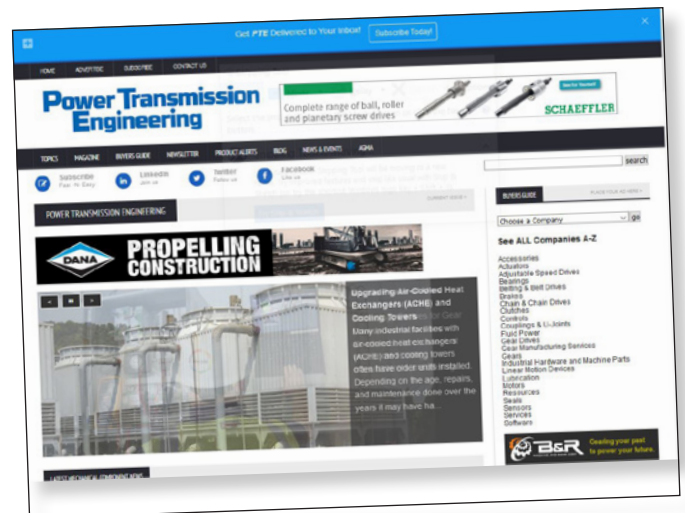

# Power Transmission Engineering

### FOR MORE INFORMATION

1840 Jarvis Avenue, Elk Grove Village, IL 60007

Phone: 847-437-6604

Fax: 847-437-6618

Email: [publisher@powertransmission.com](mailto:publisher@powertransmission.com)

[www.powertransmission.com](http://www.powertransmission.com)

**JIE  
DRIVE**

IP69K

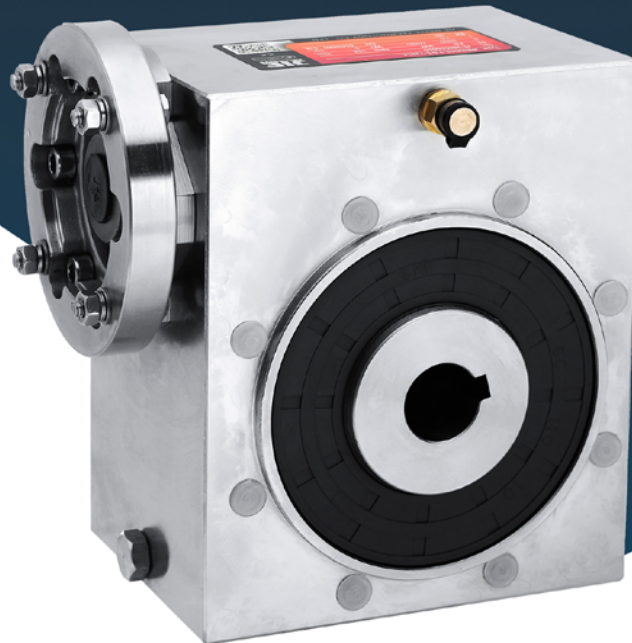

## **JRESND Stainless Steel Worm Gear Unit**

- Ratio 7.5 - 100
- Size 40 / 50 / 63
- Viton & NBR Seal
- Laser Nameplate
- Material Stainless Steel 304
- NEMA Inputs 48 / 56 / 140 TC
- Food Grade Lubrication Option
- Hollow / Single / Double Output Shaft & Torque Arm

### **2 Day Delivery**

- Assembled in USA

[www.jie-drives.com](http://www.jie-drives.com)    [Info@jie-drives.com](mailto:Info@jie-drives.com)    +1 630 580 9986

# We Can Handle It!

The only totally U.S. owned manufacturer of Link-V-Belting

## DuroDrive

LINK V-BELT

**BDH BELTS**

Ph 717-871-0994  
[www.bdhbelts.com](http://www.bdhbelts.com)

Fax 717-871-0995  
[sales@bdhbelts.com](mailto:sales@bdhbelts.com)

**Engineering sMart** is your resource for the latest in great ideas from our advertisers. Check this section every issue for sMart Engineering ideas and technology.



For information about advertising, contact Dave Friedman at (847) 437-6604 or

[dave@powertransmission.com](mailto:dave@powertransmission.com).



# B&R

MACHINE AND GEAR CORP

[BRGEAR.COM](http://BRGEAR.COM)



# Screw Jacks

The NEW Zimm ZE screw jack series offers all the connecting, drive and safety components from a single source.

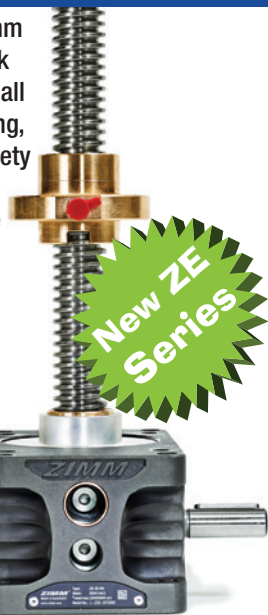

**ZIMM** USA  
by **DIEQUA**  
screwjacks.com 800-804-8619

# Helical Worm Speed Reducers

Our helical worm gearmotors and speed reducers provide unmatched performance, durability, and design flexibility.



- 6 sizes, fractional to 10 HP
- Multi-stage Ratios
- NEMA, IEC, or Servo Motor Adapters
- Low Backlash & Efficiency up to 90%
- Multiple Mounting Configurations

**DIEQUA**  
Corporation

diequa.com/pte 800-280-5402

## Precision Mechanical Components & Assemblies

Standard Industrial Components | Made To Print Parts

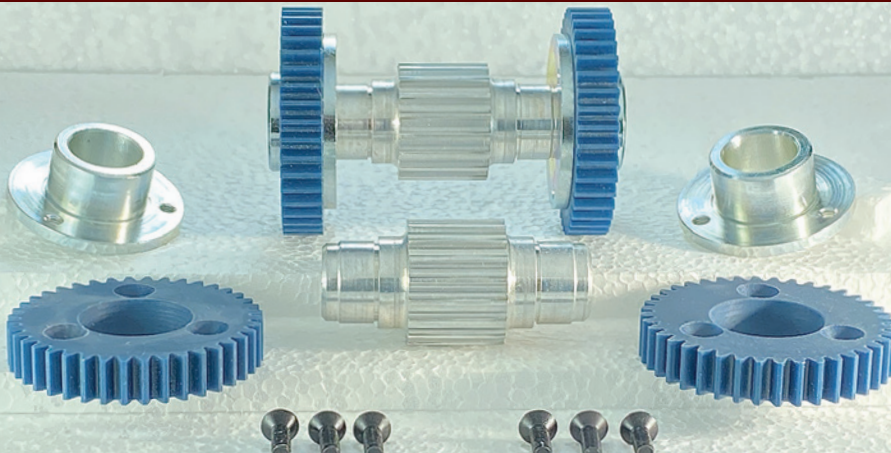

Gears, Pulleys, Shafts, Bearings, Couplings, Fasteners, Custom Gear Boxes  
Value Added Features and Services

Engineering, Refurbishing & Design  
Custom Made To Print Parts  
Modified Standard Parts  
Assemblies & Sub-Assemblies  
Custom Mounts For Shafts  
Build Sub-Assemblies And Complete Assemblies  
Prototype Work

- ▶ Press bearings into pulleys
- ▶ Assemble bearings to shafts
- ▶ Set backlash on gears
- ▶ Assemble drive boxes
- ▶ Straightening
- ▶ Welding
- ▶ Kitting
- ▶ Plating / Custom Coating
- ▶ Heat treat

ADD

- Grooves • Flats • Keyways • Pins
- Threads • Staking • Pressing
- Testing

**Nordex**  
INCORPORATED

Nordex.com Sales@nordex.com Eng@nordex.com  
Phone: (800) 243-0986 or Call: (203) 775-4877

www.sipco-imak.com

## VISIT OUR NEW WEBSITE & GEARBOX CONFIGURATOR



Our Services



INTUITIVE GEARBOX SELECTION TOOL,  
DOWNLOAD .STP .DWG AND .PDF FILES



Helical Gear Motors



Planetary Gearboxes

Industrial Gear Drives



BUILT IN THE USA!

**SIPCO i.Mak**  
Gearboxes and Drives

281.480.8711

sales@sipco-imak.com

# WE'RE

# ALL IN

# MOVING THE FUTURE.

**3M** Science.  
Applied to Life.™

  
Advanced Heat Treat Corp.

  
ASH GEAR  
AND SUPPLY

  
Bent Gear (India) Pvt. Ltd.

**Blaser.**  
SWISSLUBE

**BK** BOURN  
& KOCH

  
**BUNTING**  
Bunting-Drubs

**CAPSTAN**  
ATLANTIC

**CGI**

Circle  Gear

  
**Columbia Gear**  
Corporation  
A SUBSIDIARY OF INDUSTRIAL MANUFACTURING COMPANY

**Dontyne**  
Systems

  
**DOPPLER**  
GEAR COMPANY

**DTOR**  
PERFECTION MOVES US

**GDVS**  
TECHNOLOGY  
AMERICA

**EMAG**

  
ENGINEERED  
ABRASIVES™

  
euro • tech

  
**FOREST CITY GEAR**

  
**FOERSTER**

**GEAR**   
motions  
Precision in Motion

**GEAR**Solutions

**Gleason**

  
GREAT TAMAR GEAR

**GWJ**  
TECHNOLOGY

  
**AMERICA**  
**HAINBUCH**  
WORKHOLDING TECHNOLOGY

**HAYES**  
MANUFACTURING

  
**HELIOS**  
gear products

**HOFFMANN**

**ph HORN ph**

  
**IMT**  
FORGE GROUP

  
Member IMC Group  
**Ingersoll**  
Cutting Tools

**I**   
nnovative  
BACK & GEAR  
CELEBRATING 25 YEARS  
We Help You Move the World

  
**IPM**  
Precision Machining  
& Gear Cutting

  
**KAPP NILES**

  
**KLINGELBERG**

**LIEBHERR**

  
**LOUIS BELET**  
Swiss cutting tools

  
**MTB** Machine Tool Builders  
BUILDING • REPAIRING • SERVING

**MIL** MAGNETIC  
INSPECTION  
LABORATORY, INC.

**MB**  
METAL  
TECHNOLOGIES



# MOTION+POWER TECHNOLOGY EXPO

**SEPTEMBER 14-16, 2021**

AMERICA'S CENTER CONVENTION COMPLEX  
ST. LOUIS, MO



American  
Gear Manufacturers  
Association



Power Transmission  
Engineering

AGMA and its members are leading the power transmission industry into a stronger 2021. Join AGMA, the exhibitors you see listed here — industry leaders and experts in all sectors of manufacturing — in our commitment to MPT Expo and the global supply chain.

**IF WE ARE ALL IN, WE ALL WIN.**



LEARN MORE AT [MotionPowerExpo.com](http://MotionPowerExpo.com)

# A Ten-Minute Introduction to Digital Filters

Don Labriola, Quicksilver Controls

Filtering is needed in various control and communication applications. These can be both continuous time— analog filters, or sampled data— called discrete or digital filters. The basics of the filters can be understood in a few minutes, a “complete” understanding could be a thesis and would not cover everything. We will dive into the basics of digital filters in this article, including how to use a spread sheet to implement a simple low-pass filter.

Filters may be viewed by how they alter an input signal, both in time and when looking at a range of frequencies. For this article we will start with the basic low-pass filter, meaning the filter allows low frequency signals to pass without being diminished or attenuated, while reducing or attenuating higher frequencies.

Figure 1 shows a simple RC (resistor-capacitor) low-pass filter. The same transfer function is observed in mechanical systems where one element varies the flow based on differences, while another element integrates the flow. For example, for hydraulics this would be a flow restriction and an accumulator or a tank.

## Output vs. Time - ANALOG

The low-pass RC filter in Figure 1 can be studied by looking at its time response. To simplify, we will assume the capacitor starts out discharged, and then  $V_{in}$  steps to  $1v$ .

This filter is designed for 10Hz low-pass cutoff—that is at 10 HZ half of the power (70.71% of the voltage) will

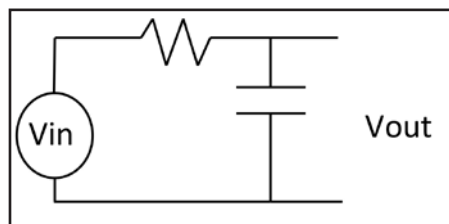

Figure 1 Low-pass analog filter.

pass through the filter. As you can see, initially the capacitor will charge at a higher rate, as the voltage across the resistor is the full 1 volt input (when the capacitor voltage is zero). As the capacitor charges, less voltage will be across the resistor, so the current will drop. As the voltage across the capacitor reaches close to the full 1 v input signal, the voltage across the resistor drops to almost zero, so the current will drop to almost zero, and the capacitor stops charging.

Now consider if the input reverses before the capacitor has fully charged; the output voltage will only change a fraction of the input voltage. The faster the signal reversals, the less the output will change. Thus, sufficiently low frequencies will “pass” through this filter, while higher frequencies are attenuated or “stopped.”

**Digital filter.** The digital filter approximates this response by simulating the interaction of the resistor and capacitor with the input voltage. We look (sample) only at certain times, but if we sample at least 2x faster than the highest input frequencies present, we get a fairly good approximation.

**Capacitor.** The voltage across the capacitor is proportional to its charge, which is the time summation (Integral) of the current into the capacitor. The Digital simulation of Figure 1 is shown in Figure 3. The box labeled 1/Z is just a delay box (a latch or memory location): it holds the previously sampled output estimate until we update the simulated estimate, implemented as a memory location when implemented on a computer. The circles represent addition / subtraction functions, and the tapered

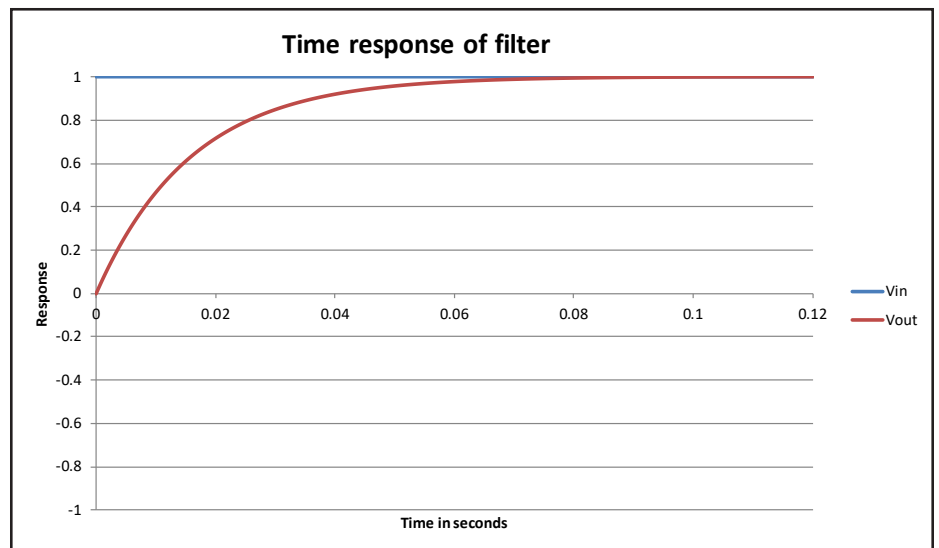

Figure 2 Time response of a low-pass filter.

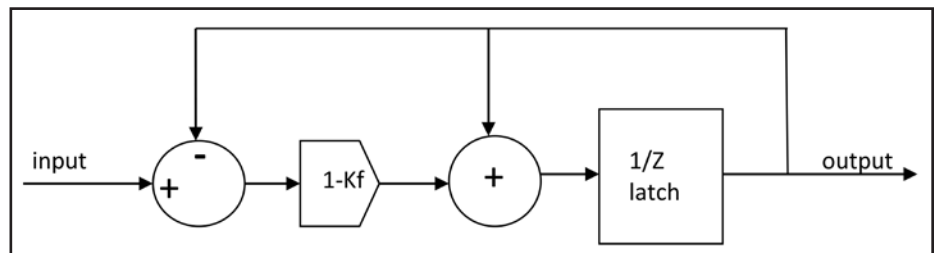

Figure 3 Digital filter implementation.

box is a multiplication operation.

The simulated capacitor voltage is the sum of the simulated current, taken at discrete time steps (the total charge divided by the capacitance in farads). As long as the sampling rate is fast compared to the input variations, this is a good approximation. In the computer, this is done by taking the previous “charge” estimate value from memory and adding the new charge (current  $\times$  time step) each update cycle and saving the result. The “current” is calculated from the difference in the input voltage and the capacitor voltage. To save an extra multiplication every cycle and the resulting rounding error, the circuit has been normalized by  $1/C$  so that the capacitor is modeled as  $1F$ , and the resistor as  $RC$ ; this results in the same  $RC$  time constant for the simulated circuit. The estimated capacitor value is thus updated each sample period. For the QuickSilver controllers, this is typically every 120 microseconds — about 8,333 times per second.

In the digital implementation, the  $T/(R \times C)$  becomes  $1 - Kf$ , where  $Kf$  is the feedback term, always less than 1, and  $T$  is the sample period;  $Kf$  represents the fraction of the previous charge remaining on the capacitor after one sample period if the input were zero. It may also be easily observed that the new output value will equal the previous output value if the input is equal to the old output value. Said another way, the filter has a gain of one for DC inputs.

Many modern processors can multiply as fast as they can add. To speed up the calculations, the filter can be re-arranged as shown in Figure 4.

Although the simulation is simplified, it actually produces good results as long as the sampling rate is sufficiently fast compared to the time response of the filter and at least twice as high as the highest frequency of the input waveform.

The spread sheet related to this article [[www.quicksilvercontrols.com/SP/WP/QCI-WP005\\_DigitalFiltersLesson.xlsx](http://www.quicksilvercontrols.com/SP/WP/QCI-WP005_DigitalFiltersLesson.xlsx)] shows the step response as the first sheet, and the frequency responses in Figures 5, 6, and 7.

Figure 5 shows a 50 Hz low-pass filter with a 100 Hz input sine wave. There is a slight start up transient when the input

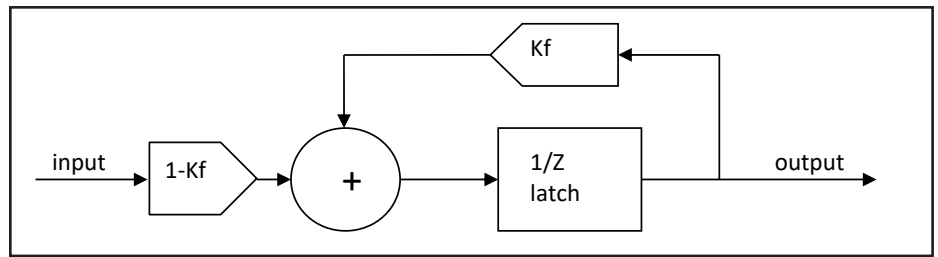

Figure 4 Simplified low-pass digital filter.

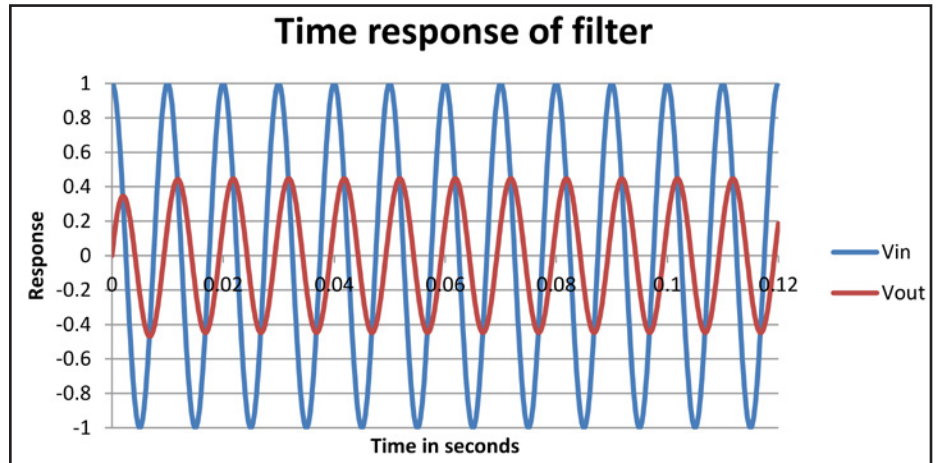

Figure 5 100 Hz input, 50 Hz cutoff selected.

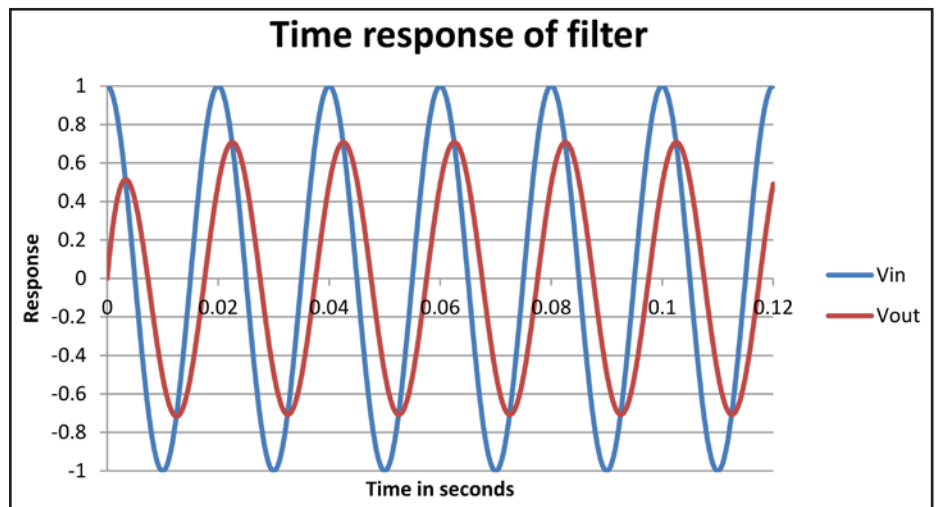

Figure 6 50 Hz input, 50 Hz cutoff.

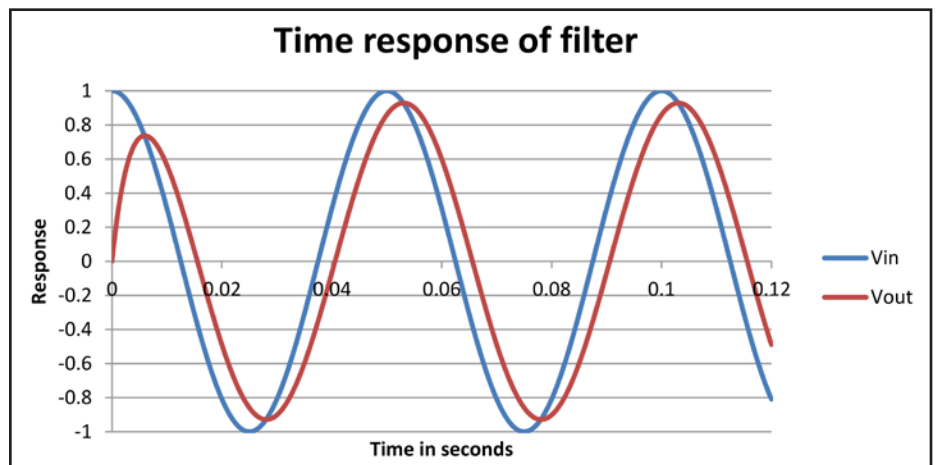

Figure 7 20 Hz input, 50 Hz cutoff.

is switched on. In the example, the first cycle of input started at peak value but was only on for half of a sine peak before reversing. The filter did not fully charge on the first cycle, so it takes several time constants for the resulting DC offset to settle). The steady state amplitude is  $1/((F_{in}/F_c)^2+1)^{.5} = 1/(2^2+1)^{.5} = .447$

When we repeat this with a 50Hz input to a 50Hz filter, the steady state amplitude is  $1/((50/50)^2+1)^{.5} = 1/\text{Sqrt}(2) = .707$

This is the half power point called the cutoff frequency.

We repeat with a 20Hz input into a 50Hz filter and we get a steady state response amplitude of:  $1/((20/50)^2+1)^{.5} = 0.928$  (Fig. 7).

Each of these filters is included as a sheet in the spread sheet referenced above. You can change the selected cutoff frequency and input frequency. The sampling time in the spread sheet is 120uS, which corresponds to the filters used in our QuickSilver products. This corresponds to 8,333Hz. The input frequency for this implementation should remain below 4166Hz (1/2 sampling rate) for proper operation.

### Calculating Kf for the desired cutoff frequency

For the analog version, consider the capacitor is charged to 1v, and at time=0 we attach the resistor.

The natural (decay) response for the RC circuit will be  $V(t) = V_0 \times e^{-(t/RC)}$ , a simple exponential decay.

We can do the same for the digital

circuit by loading the register holding the estimate to 1 while keeping the simulated input voltage at zero. The output would start at 1. At the next sample period the output would be  $1 \times Kf = Kf$ . The 2<sup>nd</sup> sample period it would become  $Kf \times Kf = Kf^2$  at the second sample period. In general, it would drop to  $Kf^n$  at sample interval n. Time(n) = sample period  $\times n = 120e-6 \times n$  for this particular filter.

Going back to the the analog filter we are simulating: this filter has a natural response (for an initial charge voltage =1) of  $v(t) = e^{-(t/RC)} = e^{-(2 \times \text{PI} \times F_c \times t)}$

where the cutoff frequency  $F_c = 1/(2 \times \text{PI} \times RC) \Rightarrow RC = 1/(2 \times \text{PI} \times F_c)$

If we set the transient output for the time series equal to the transient output for the analog filter (looking only at the sampled times),

$$e^{-(2 \times \text{PI} \times F_c \times t)} = Kf^{t/T_s}$$

Where  $T_s$  is the sample time and  $F_c$  is as defined above, we can take the natural log of both sides, isolate  $Kf$ , and then take the natural antilog of both sides and we have:

$$Kf = e^{-(2 \times \text{PI} \times F_c \times T_s)}$$

This calculation is shown in cell F4 of the respective worksheets.

**Limits of simulation.** This simple model of the low-pass filter works well as long as there are enough samples compared to the frequency components in the input. For inputs containing frequencies of more than half the sample frequency, an effect known as "aliasing" will occur, which will cause frequencies in the output that are

different from those that were applied to the input (down-mixing for those familiar). These are normally not desired and should normally be avoided. (Aliasing = one frequency taking on an alias as a different frequency due to the sampling process.) Carefully controlled aliasing can be used to mix RF frequencies to an IF by proper sampling, so this effect can be used effectively. But the total bandwidth of the input signal still needs to be limited to prevent unwanted mixing!

This aliasing effect may be seen in movies showing the propeller of an airplane or the blades of a helicopter that appear to stop spinning or to reverse direction. In the case of the movie, the camera is commonly at 24 frames-per-second for film (often other speeds for electronically captured videos). If a propeller is spinning right at 24 revolutions per second (1,440 rpm) the camera catches successive rotations of the propeller on each subsequent frame, making the propeller appear to be stationary. A little faster and the propeller will appear to be slowly turning forward, a little slower and the blade will appear to reverse direction. A serious issue may occur if older fluorescent lighting (non-electronic ballast) are powered from a single phase (all flashing at 120Hz) in a machine shop. When observing a tool connected to a synchronous motor, the strobe effect of all of the lights flashing at rotational rate of the motor may cause the tool to appear to be stationary when it is actually spinning. An induction motor with a small slip can appear to be moving slowly. In both cases the strobing lights may make the rotating device appear safe to touch! This is one of the reasons that the fluorescent lighting was normally wired with adjacent lights wired to successive phases of 3-phase power in machine shops. The combined light would thus always have one or more of the sets of lights glowing, which eliminates the strobe effect that would otherwise make the spinning parts appear to be slow or stopped.

Sampling a fast-moving waveform can cause the same effects for the sampled data. In Figure 8 the input waveform is 8.033kHz and is sampled at 8.333kHz. The sampling is less than twice the frequency component of the

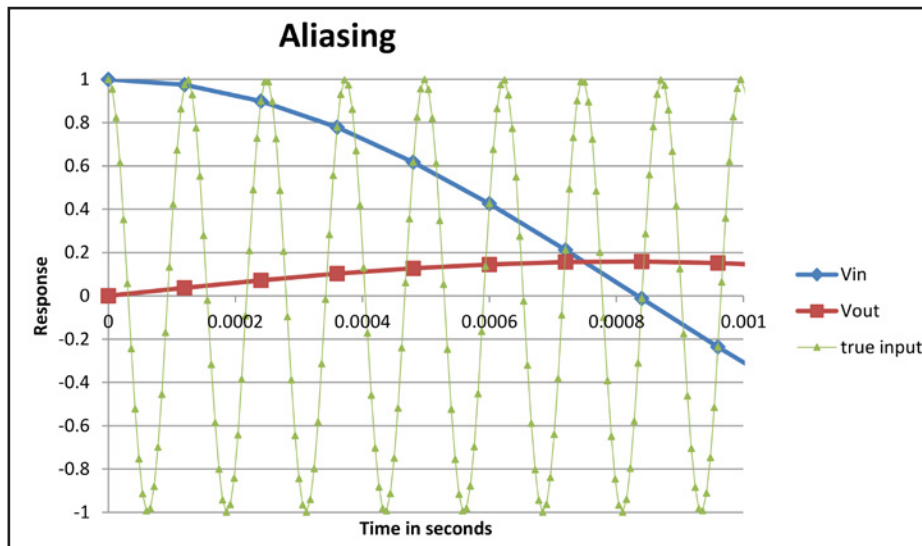

Figure 8 Aliasing: sampling an 8.033 kHz waveform at 8333 Hz.

waveform, so the sampling causes mixing between the actual waveform and various harmonics of the sampling rate. In this case, the first harmonic of 8,333 Hz sampling rate is mixed with the 8,033 Hz signal, resulting in a 300 Hz mixing, which then is filtered and shows up in the data.

The green “true input” shows this data if it was sampled 20x faster. The blue “Vin” diamond that overlaps the green arrowhead shows those points of the actual data that gets collected by the sampling at a rate that is less than twice the input data frequency.

Although no 300 Hz signal was present in the input waveform, this 300 Hz aliasing artifact shows up. Although the 50 Hz filter should have almost completely filtered out an 8 kHz signal, a significant 300 Hz signal appears at the output of the filter. If this is a control system, significant mechanical problems can result! If the input noise is near the sampling frequency, the alias can show up as a DC baseline that is varying around, which is essentially impossible to filter out.

This issue can be addressed by filtering the analog input with a continuous filter or by sampling at a much higher frequency, filtering sufficiently to remove the high frequency components, and then down-sampling (decimating) the data prior to subsequent processing at a lower processing rate.

This aliasing can appear in surprising places in sampled data. On one optical sampling system in which I was involved, a flash lamp was used to take data from multiple sample containers as they spun between the flash lamp and a polychromatic (multi-color) detector. The data was taken over periods as long as several minutes to watch chemistry reactions occurring. The flash lamp had a certain amount of flash-to-flash variation, which was expected, and which the math tried to handle as random. In looking at the data we would occasionally see a large saw-tooth-shaped artifact that was quite significant in amplitude and sometimes has positive ramp, sometimes negative ramp, and had a wide variety of frequencies. A little more analysis showed that the high voltage power supply powering the flash lamp had a simple hysteretic

voltage regulator: when the voltage got below a certain threshold, the switch mode power supply would add one pulse of energy to the storage capacitor. The voltage waveform was thus a slow decay with an occasional step up. The actual pulsing to keep the voltage stable was on the order of a few kHz once the voltage had been reached. This variation happening at a couple thousand times-per-second is what got played out over minutes when the temperature of the system caused the frequency of the oscillator in the power supply to slowly drift to exactly the right (wrong!) frequency, compared to the approximately 1 sample point-per-second-per-sample when we were taking data. We changed the power supply design to be proportional rather than hysteretic—this greatly reduced the amplitude of the ramp in power supply voltage (and the resulting flash intensity), and the resulting ramp in the measured data disappeared!

I encourage you to download the spread sheet and experiment with the results! **PTE**

#### For more information.

Questions or comments regarding this paper? Contact Donald Labriola P.E., President, QuickSilver Controls, Inc. at [don\\_labriola@quicksilvercontrols.com](mailto:don_labriola@quicksilvercontrols.com)

**Donald Labriola P.E.** is president at QuickSilver Controls, Inc. He has been working with step motors since high school, and has had these motors operating field-oriented closed loop control since 1984.

[don\\_labriola@quicksilvercontrols.com](mailto:don_labriola@quicksilvercontrols.com)



# Analysis of the Operational Behavior of a High-Speed Planetary Gear Stage for Electric Heavy-Duty Trucks in Multi-Body Simulation

Christian Westphal, Jens Brimmers and Christian Brecher

## Introduction

More restrictive environmental requirements are prompting vehicle manufacturers to develop electrically powered mobility solutions. In the field of commercial vehicles, distribution transport is of great interest due to its impact on the environment in urban areas. Within the research project “*Concept ELV<sup>2</sup>*,” an integrated drive unit consisting of an electric machine and gearbox for heavy-duty distribution traffic is being developed and tested. The sub-project “*Concept ELV<sup>2</sup> Technology Development*,” which is being carried out in cooperation with the Daimler AG, the Institute for Automotive Engineering at RWTH Aachen University (ika) and the Institute of Electrical Machines at RWTH Aachen University (IEM), includes the development of an innovative and efficient e-axle at RWTH Aachen University. Due to the high rotational speed of electric machines compared to usually used diesel engines, the transmission topology changes significantly. With a high power density combined with a high transmission ratio, planetary gearboxes are increasingly being used in these applications.

With the trend towards electrically driven vehicles, the reduction of driving resistances and thus optimization of power density is of great interest due to the limited energy density of batteries. However, increasing power density usually results in higher load-related displacements in the transmission systems. Simulation methods should be used to evaluate the influence of structural stiffness on operational behavior since test bench investigations are time and cost-intensive. Especially in the case of automotive and commercial vehicle transmissions, interactions between the transmission stages should be taken into account, and, if possible, overall transmission systems should be simulated. The objective of this report is the analysis of the influence of a planet pin position error on the operational behavior under consideration of different simulation model configurations in MBS. Therefore an FE-based method will be developed and a verification with other simulation methods will be performed.

## Multi-dimensional Excitation Effects in Planetary Gear Stages

In contrast to single or multi-stage cylindrical gearboxes, the dynamic misalignment behavior of planetary gear stages is more significant due to the kinematic coupling between the tooth meshes and the power flow split. A planetary gearbox with three planets already shows a static overdetermination for non-flexible gear components (Ref. 1). In addition to the number of planets, there are other factors that influence the dynamic operational behavior of planetary gearboxes. A division of the influences on the operational behavior into three main groups is shown in Figure 1. A distinction is made between geometrical constraints, manufacturing deviations, and system stiffness. The geometrical constraints include, in addition to the number of planets, the mesh sequence, which has an effect on the temporal sequence of the meshing stiffness. In contrast to planetary gearboxes with spur gears, the helix angle of helical gears leads to excitations by the opposite axial forces of the sun-planet and the planet-ring gear mesh (Ref. 2).

To evaluate the operational behavior of planetary gearboxes, it is very important to consider the system stiffness. The load-related deformations of the components, such as the planet carrier, cause a multi-dimensional misalignment of the gears in the tooth contact (Figure 1). In particular, the interaction with additional gear stages and thus forces acting externally on the planetary gearbox can have effects in form of load-related displacements (Ref. 3). This occurs especially with power density optimized gearboxes. The static

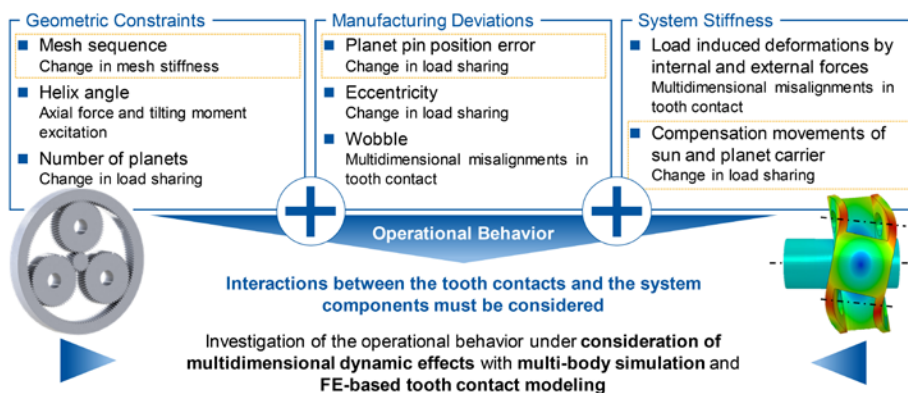

Figure 1 Operational behavior of planetary gearboxes.



overdetermination of a planetary gearbox can be reduced with movable components. Then the stiffness of the bearings in addition to the mass inertia of the movable component must be considered in the simulation. The effects described in Figure 1 are examples since interactions and overlapping of those effects can occur.

Manufacturing deviations are a main influencing variable in the excitation of gears. In case of planetary gearboxes this effect is intensified due to the kinematic overdetermination. The torque sharing between the planets is particularly influenced by planet pin position errors and eccentricity at the sun or planet gear. Similar to cylindrical gears, manufacturing deviations in form of wobble can also have a significant negative influence on the operational behavior. In addition for planetary gearboxes, a wobble of the planet carrier must be taken into account.

Extensive research contributions exist for the static and dynamic calculation of the torque sharing in planetary gearboxes, whereby mostly a plane modeling approach without three-dimensional displacements of the gears is used. If the effects of manufacturing deviations and stiffness influences on the operational behavior of planetary gearboxes are investigated, simplified models are often used to calculate the tooth stiffness or the contact areas are calculated with analytical methods (Refs. 2, 4-7).

An overall system modeling approach including the local stiffness changes in the tooth contacts due to the misalignment of the gears and system components with a focus on the influence of manufacturing deviations is not possible with simplified models. The FE-based calculation of the mesh stiffness considering the misalignment in the tooth contacts in the dynamic multi-body simulation (MBS) offers the possibility to simulate the interactions between the tooth contacts and the system components (Ref. 8).

Modally reduced FE-models can be integrated for the stiffness-appropriate modeling of the components so that entire transmission systems can be simulated. In this report a method for the simulation of planetary gearboxes

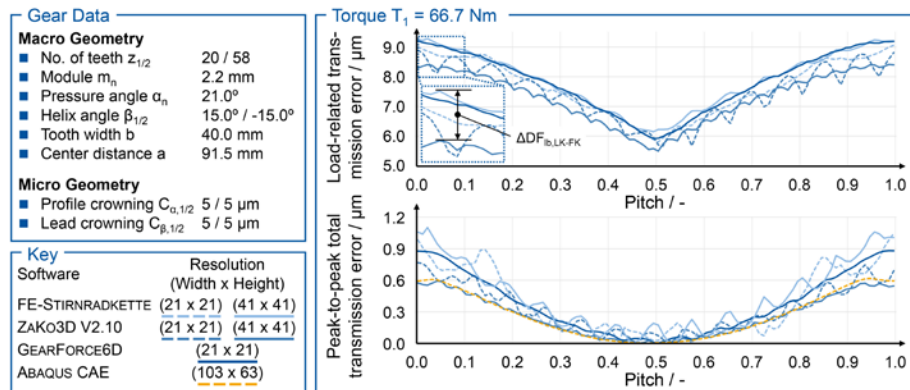

Figure 2 Verification of load-induced transmission error.

in dynamic multi-body simulation is presented. For this purpose, a verification of the simulation results with quasi-static methods will be carried out in the following chapter.

### Verification of the Developed Tooth Contact Calculation in MBS

To verify the tooth contact calculation *GEARFORCE6D* developed by the authors, a comparison with validated programs is performed. For this purpose, simulations with *FE-STIRNRADKETTE V4.2.24*, *ZAKO3D V2.10*, and *ABAQUS CAE* are carried out (Refs. 9-10). The *FE-STIRNRADKETTE* determines the contact line based on an analytical approach. In contrast, the contact area is numerically calculated in *ZAKO3D*, *ABAQUS*, and the method presented here. To reduce the numerical effort, the new method approximates the contact area by a contact line, while *ZAKO3D* and *ABAQUS* use the entire contact area.

To evaluate the differences, calculations of the load-related transmission error and the total transmission error are performed with different point-grid resolutions of the tooth flanks. The general FE software *ABAQUS CAE* is used as a reference for the total transmission error due to the general contact calculation approach. The sun-planet mesh of a planetary gearbox is used as a gear set example. In addition to the basic gear data, the calculated transmission errors of the various simulation methods for a pinion torque of  $T_1 = 66.7$  Nm are shown in Figure 2. In the upper diagram on the right side in Figure 2, the load-related transmission error is shown over one

pitch. The higher frequency deviations of the results of *ZAKO3D* are smaller in their amplitude at the finer resolution of 41x41 points than at the coarser resolution.

For the *FE-STIRNRADKETTE*, there are also differences in the results when using different flank resolutions. At a resolution of 21x21 points, deviations can be seen that are caused by the 20-node hexahedral elements of the FE-model. The lower stiffness of the nodes on the element edges compared to the nodes of the vertices has an effect on the resulting overall stiffness curve in the form of deviations. This stiffness variation becomes visible in the load-related transmission error. At a resolution of 41x41 points the deviations of the results of the *FE-STIRNRADKETTE* are reduced. In comparison, the deviations of the results of *GEARFORCE6D* are already small even at a resolution of 21x21 points. This is due to the 8-node hexahedral elements of the used FE-model, which are also used in *ZAKO3D* and *ABAQUS*. With this FE element type there are no nodes on the edges, so that eight 8-node FE elements are used instead of one 20-node FE element. A disadvantage of the 8-node FE elements is the longer calculation time due to the higher number of elements.

There is a difference between the methods with a line-based and surface-based contact approach. The load-related transmission errors of the *FE-STIRNRADKETTE* and *GEARFORCE6D* show a variable offset of up to  $\Delta DF_{lib, LK-FK} = 0.8 \mu\text{m}$  in comparison to *ZAKO3D* with fine point grid and surface contact approach.

In the lower diagram of Figure 2,

the fluctuation of the peak-to-peak total transmission error is shown for the different simulation approaches. First the high correlation between the results of ZAKO3D with fine resolution and ABAQUS is visible. In addition, a division of the methods according to contact approach is possible, so the results with a line-based contact approach (FE-STIRNRADKETTE and GEARFORCE6D) are above those with surface contact approach (ZAKO3D and ABAQUS). A possible explanation is an increase in the stiffness of the tooth contact by including several contact points in the profile direction when using a surface contact approach. Additional contact points are simulated in the mathematical spring model by additional springs, which increase the overall stiffness in a parallel connection. The variations in the results of the FE-STIRNRADKETTE depend on the chosen element types. The results of GEARFORCE6D show the smallest higher frequency fluctuations in addition to the results of ABAQUS. Due to the line-based contact approach, the

results are higher than of those with a surface contact approach (ABAQUS and ZAKO3D).

Thus, the newly developed contact calculation of GEARFORCE6D represents a numerically efficient method for calculating the stiffness of tooth contacts. Especially for dynamic multi-body simulation, the reduction of periodic deviations is of great importance, as these otherwise cause an incorrect, numerically caused excitation in the entire system.

For the verification of the pressure calculation, simulations with the FE-STIRNRADKETTE, ZAKO3D, and ABAQUS were carried out and evaluated. The pressure distribution on the tooth flank for one pitch is shown in Figure 3 on the right. The results of ZAKO3D with a fine flank point-grid resolution (41x41 points) and ABAQUS show a high correlation. With a resolution of 21x21 points in ZaKo3D, the calculated pressures are up to 30% lower compared to the other methods. This is also evident when comparing the pressure curve in the middle of

the tooth width, see Figure 3 top left. The pressure distributions of the FE-STIRNRADKETTE and GEARFORCE6D show both qualitative and quantitative similarities. The slight differences between the results of the line-based methods (FE-STIRNRADKETTE and GEARFORCE6D) and the area-based methods (ABAQUS and ZAKO3D) are due to the contact calculation method itself.

In summary, it can be stated that GEARFORCE6D allows the calculation of the transmission error and the tooth flank pressure with a high accuracy. Compared to the other simulation methods, the results show a high correlation. The number of points required to describe the numerical contact was in comparison always the lowest with an equal quality of results. In contrast to analytical contact methods used in the FE-STIRNRADKETTE, which also provide good results with a low flank resolution, GEARFORCE6D allows the consideration of displacements of the gears in the numerical contact model.

### Effect of Manufacturing Deviations on the Operational Behavior of Planetary Gearboxes

Deviations from the ideal geometry occur in almost all manufacturing processes. They can usually only be reduced to a minimum at uneconomically high costs. Thus the possibility of a simulative evaluation of the effects of the deviations on the overall system behavior is even more necessary. In this chapter a multi-body simulation (MBS) model of the gear stages of an electrically driven rear axle for trucks in DASSAULT SYSTEMS SIMPACK 2019X is built up. The developed method GEARFORCE6D is used for multi-dimensional simulation of misaligned tooth contacts in the dynamic MBS. In the subsequent analysis, a manufacturing deviation on the planet carrier is varied and the operational behavior is analyzed. Here the designed planetary gearbox is in the focus and is extended in the last section by a helical gear stage, the final drive.

**Introduction of the Test Gear Set and the Model Configuration.** The gear data of the designed planetary gear set

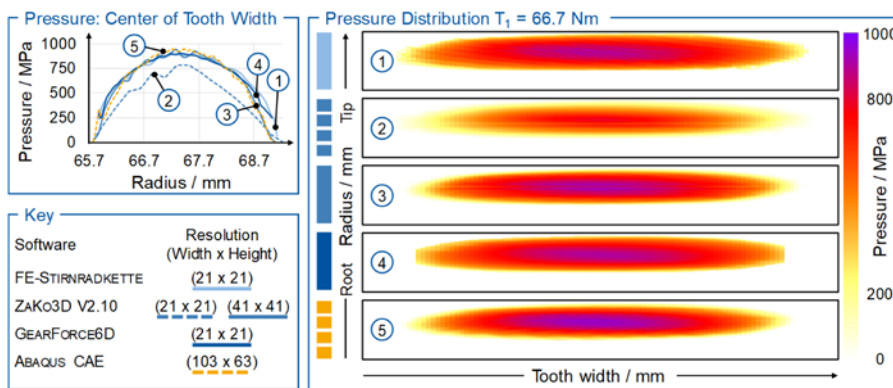

Figure 3 Verification of the pressure calculation.

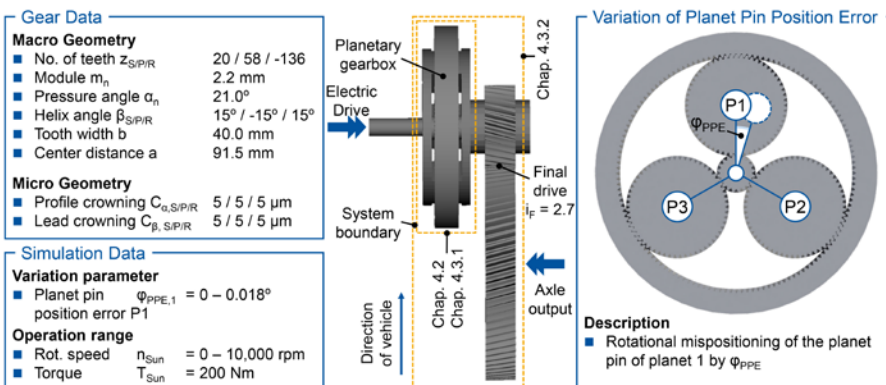

Figure 4 Introduction of the test gear set.

is shown in Figure 4. The gearbox topology is shown next to it. The planetary gearbox is used in a two-shaft operation with a fixed ring gear. Starting from an electrical machine with a maximum power of  $PEM_{max}=235$  kW, and a maximum speed of  $nEM_{max}=10,000$  rpm, the power is transmitted via the sun and the three planets of the planetary gearbox to the planet carrier. From there the power is transmitted via a helical gear stage to the differential cage and thus to the axle. The electrical machine, the gear housing, the differential, and the axle are not part of the simulation model but could be simulated in further investigations.

The planet pins are modeled as pinion shafts and are supported on both sides in the planet carrier. The planet carrier is supported by bearings on the input and output side in the reference coordinate system.

For the sun shaft, a fixed/floating bearing concept was selected. The radial stiffness of the floating bearing, which is located closer to the sun gear, is varied in the simulations. For the bearing stiffnesses empirical values were used, since the bearing selection was not yet carried out in the development process. To simulate the stiffness of the components, the sun shaft, the planet carrier, and the planet pins are integrated as modally reduced FE-bodies created with ABAQUS.

The simulated operating conditions are selected in the power range of the electrical machine. To analyze the dynamic operational behavior, a speed run-up of  $n_{Sun}=0-10,000$  rpm is simulated at a constant torque of  $T_{Sun}=200$  Nm, see Figure 4 bottom left. The electric motor can provide this torque over the entire speed range. This report focuses on the influence of a planet pin position error on the operational behavior. A planet pin position error describes a rotational mispositioning of the planet pin of the first planet. The position of the planet pin is thus rotated by the angle  $\varphi_{PPE}$ , see Figure 4 right. In the following sections, the planet pin position error is varied for different gearbox configurations from  $\varphi_{PPE,1}=0^\circ$  to  $\varphi_{PPE,1}=0.018^\circ$ . In addition, the radial bearing stiffness of the floating

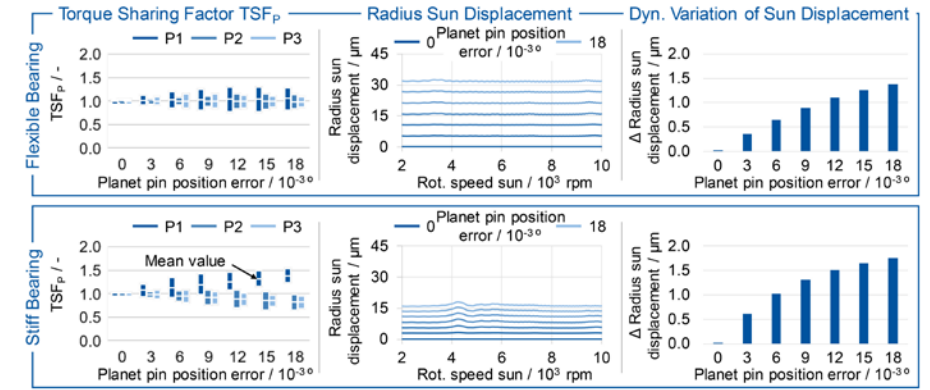

Figure 5 Torque sharing and sun displacement with symmetrical mesh sequence.

bearing of the sun shaft is varied so that the effects can be described for a *stiff* ( $C_{Radial,Sun}=400$  kN/mm) and a *flexible* ( $C_{Radial,Sun}=4$  kN/mm) sun shaft bearing.

In the analysis of the simulation results, the torque sharing between the planet gears in the sun-planet mesh is evaluated. For this purpose, the torque sharing factor TSFP (Torque Sharing Factor) is calculated for each planet  $p$  for each time step of the speed run-up according to (Ref. 1) and shown as maximum, average, and minimum value. In addition, the radius of the sun shaft trajectory and the dynamic radius variation around the mean radius are evaluated. Furthermore, the resulting misalignment and the occurring maximum Hertzian pressure in the sun-planet mesh is examined. Finally, the first tooth mesh order of the transmission errors between sun and planets and between sun and carrier is analyzed.

$$TSF_{p,i} = \frac{T_{p,i} \cdot n_p}{\sum_{p=1}^{n_p} T_{p,i}} \quad (1)$$

Where

$TSF$  is the torque sharing factor

$T_{p,i}$  is the torque at planet  $p$  at time step  $i$

$n_p$  is the number of planets

**Influence of Mesh Sequence.** The phase shift actually resulting from the number of teeth and assembly position causes a sequential mesh sequence. But first a symmetrical mesh sequence is simulated to compare the influence of different mesh sequences. For this theoretical application, the initial rolling positions of the gear meshes are synchronized in the simulation. The simulation model in this and the following subchapter includes only the planetary gearbox, thus

interactions with the helical gear stage are neglected.

**Symmetrical Mesh Sequence.** The simulation results for the planet pin position error variation of Planet 1 and symmetrical mesh sequence are shown in Figure 5 and Figure 6. In the case of a flexible sun shaft bearing, the influence of the planet pin position error on the mean torque sharing is only slightly visible, see Figure 5 top left. Planet 1, which is affected by the planet pin position error of  $\varphi_{PPE,1}=0.018^\circ$ , transmits in average 4.5% more torque with a mean torque sharing factor of  $TSF_{1,mean}=1.045$  than with an ideal torque sharing. However, the fluctuation range of the torque sharing factors increases significantly up to  $TSF_{1,max}=1.277$  at maximum planet pin position error. With a stiffer sun shaft bearing, the average torque sharing factor at the first planet is  $TSF_{1,mean}=1.375$  and the maximum torque sharing factor is  $TSF_{1,max}=1.519$  in the case of the highest planet pin position error, see Figure 5 bottom left.

The explanation for the higher torque sharing factors can be found in the comparison of the radial sun displacement, see Figure 5 middle. For an ideal planet pin position, the sun remains in its radial starting position, as expected. In the case of a planet pin position error, the sun shaft performs a circular motion with the rotational speed of the carrier to compensate the deviation. If the planet pin position error is  $\varphi_{PPE,1}=0.009^\circ$ , a radial deflection with a radius of the sun's movement takes place in case of the flexible bearing of  $r_{dyn,sun,flex} \approx 15.5 \mu\text{m}$ , whereas a stiff bearing only permits a compensatory movement of up to  $r_{dyn,sun,stiff} \approx 7 \mu\text{m}$ . The lower adjustment movement of the sun shaft

leads to higher kinematic constraining forces in case of the stiff bearing, which increases the transmitted torque by the protruding planet 1. The dynamic variation of the radial sun displacement over one revolution of the carrier shows smaller differences between the bearing stiffnesses, see Figure 5 right. The dynamic variation of the sun displacement also increases with an increasing planet pin position error.

The sun shaft does not perform a purely translatory movement in its compensatory movement. Due to the bearings a tilting movement is

superimposed. Thus, influences on the rotational misalignment in the tooth contact of the sun-planet-mesh can be expected. In Figure 6, the misalignment components inclination and skew in the tooth contact are converted into a resulting lead angle deviation  $f_{HP}$  according to Wittke (Ref. 11). They are shown on the left as bar plot with the minimum, average, and maximum.

Without planet pin position error, all planetary gears have a misalignment in tooth contact of  $f_{HP} = 7.0 \mu\text{m}$ . This depends on the tilting moment on the planet gears caused by axial forces and

the load-dependent deformation of the carrier. The bar height in Figure 6 on the left represents the dynamic range of the misalignment. With increasing planet pin position error, the misalignment of the individual planets differs significantly. In the contact of the first planet, which is under higher load, the misalignment components inclination and skew compensate each other with a larger planet pin position error, independent of the stiffness of the sun shaft bearing. Since the amount of the sun displacement is different for the flexible and the stiff sun shaft bearings, the compensation also results from a displacement of the planet. Thus it can be concluded that an unbalanced torque sharing leads to a more optimal displacement of the system for the highest loaded planet. Since the mean values of the resulting displacement are less influenced by the stiffness of the sun shaft bearing, higher forces have to be applied to achieve the displacement with a stiff sun shaft bearing. That is the reason for the higher torque sharing factor in Figure 5 and the higher maximum tooth flank pressure in Figure 6. The lower transmitted torque in the two planets without planet pin position error leads accordingly to a maximum tooth flank pressure that is up to 12.4% lower. Here the differences between planet 2 and planet 3 are due to dynamic effects that become visible when evaluating the maximum value.

The first tooth mesh order of the transmission error of the first sun-planet mesh shows a nearly constant excitation in case of a soft sun shaft bearing, whereas the excitation at the second and third planet decreases. In contrast, the excitation with a stiff sun shaft bearing is higher at planet 1 and is constant for the other planets. The transmission error excitation of the first tooth mesh order between the sun and the carrier, which is shown by the dashed shape, is not significantly affected in both cases of bearing stiffness.

In summary, it can be stated that a planet pin position error leads to a significant negative effect on the dynamic torque sharing for a planetary gear-set with symmetrical mesh sequence. A more flexible sun shaft bearing offers the possibility of reducing

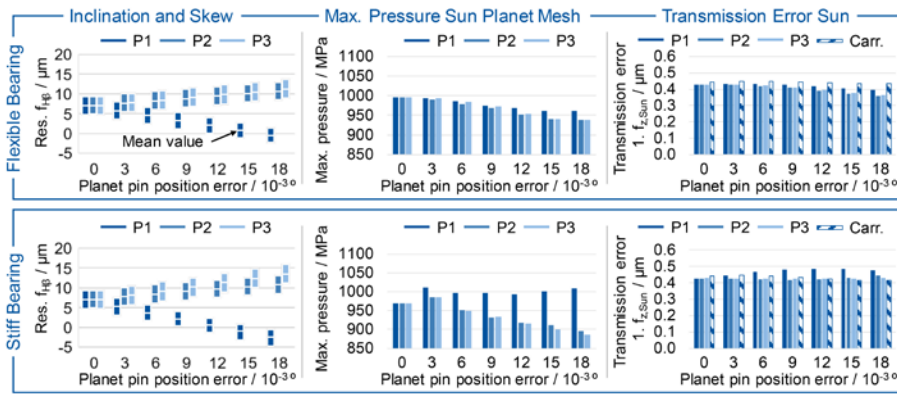

Figure 6 Sun-planet displacement and operational behavior with symmetrical mesh sequence.

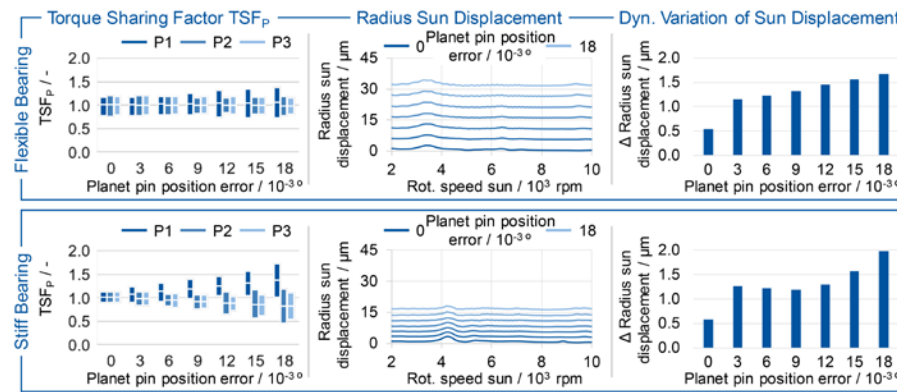

Figure 7 Torque sharing and sun displacement with sequential mesh sequence.

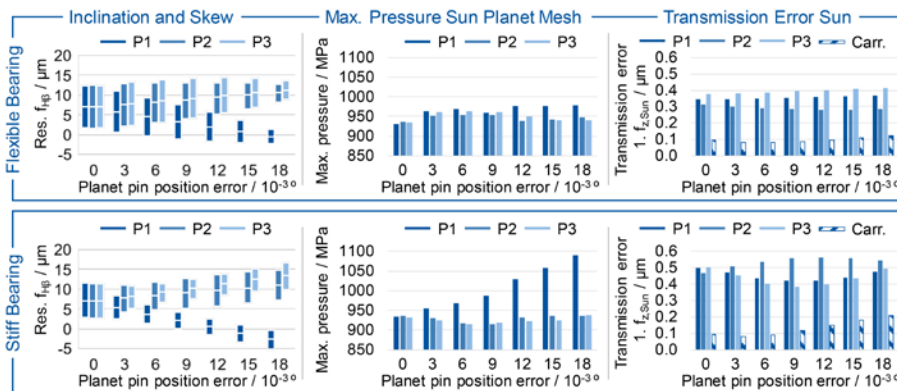

Figure 8 Sun-planet displacement and operational behavior with sequential mesh sequence.

the maximum torque sharing factors, which has positive effects on the maximum tooth flank pressure and the excitation behavior of sun-planet meshes.

**Sequential Mesh Sequence.** The simulation results with sequential mesh sequence are shown in Figure 7 and Figure 8. The average torque sharing factor is comparable to the results with a symmetrical mesh sequence. The dynamic fluctuation range of the load sharing factors is higher even without the planet pin position error. This is due to the time shift of the mesh stiffness in the sun-planet meshes because of the mesh sequence. With increasing planet pin position error the fluctuation range of the load sharing factors increases. With a planet pin position error of  $\varphi_{PPE,1} = 0.018^\circ$ , the load sharing factor of the first planet is  $TSF_{1,max} = 1.364$  for the flexible sun shaft bearing and  $TSF_{1,max} = 1.724$  for the stiff sun shaft bearing. The load applied to the tooth contact and surrounding components with a stiff sun shaft bearing is therefore up to 61.7% higher than without planet pin position error.

The radius of the sun displacement shows a low dynamic influence, which could not yet be determined with the symmetrical mesh sequence. Especially for small planet pin position errors, an increase of the dynamic radius variation can be seen, Figure 7 middle. Overall, the displacement movements of the sun gear are comparable with those of the symmetrical mesh sequence.

The misalignment in tooth contact is significantly higher than with symmetrical mesh sequence even without planet pin position error, see Figure 8. Due to the time-shifted tooth meshing and tooth forces, the planet carrier moves more, which results in higher misalignments in the tooth contact. This influence decreases with increasing planet pin position error. The planet pin position error is then responsible for the carrier movement and a compensating movement due to the mesh sequence is less significant. The fluctuation range of the misalignment in the tooth contact decreases with increasing planet pin position error. In general, the dynamic range of variation of the misalignment is smaller with a stiffer sun

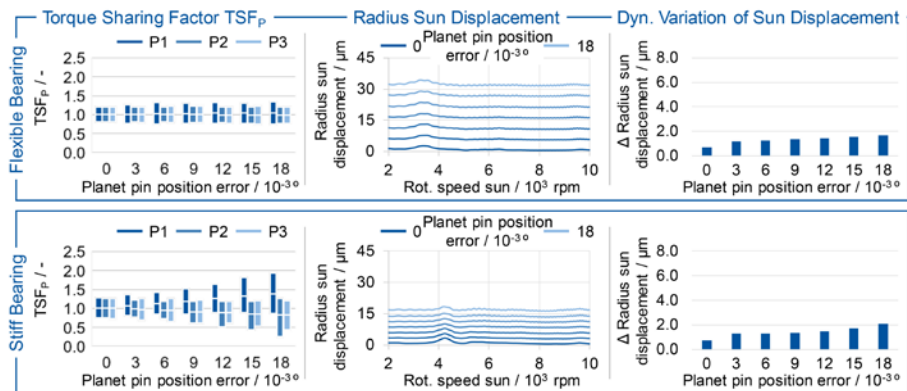

Figure 9 Torque sharing and sun displacement with tilted planet carrier.

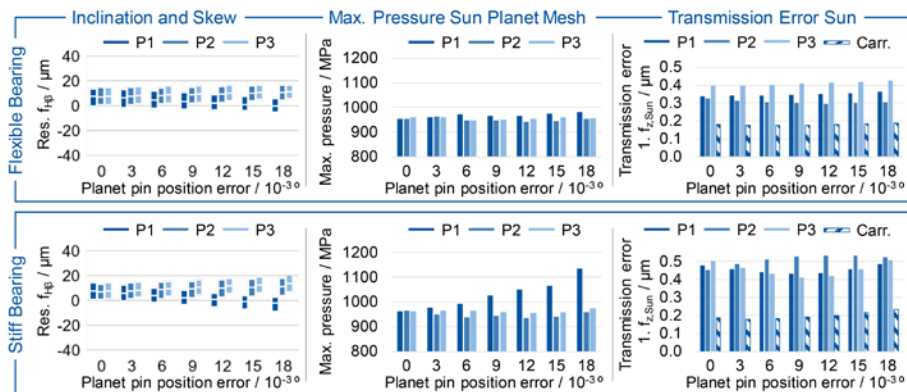

Figure 10 Sun-planet displacement and operational behavior with tilted planet carrier.

shaft bearing.

The effects of the planet pin position error on the tooth flank pressure are different for the sequential mesh sequence than for the symmetrical mesh sequence. In the sequential mesh sequence, the maximum pressure also increases with increasing planet pin position error in case of a flexible sun shaft bearing. The increase is less significant compared to the rigid sun shaft bearing. With a planet pin position error of  $\varphi_{PPE,1} = 0.018^\circ$ , and a stiff sun shaft bearing the maximum tooth flank pressure in the contact of the first planet is 11.2% higher than with a flexible sun shaft bearing. Compared to a symmetrical mesh sequence, a stiff sun shaft bearing leads to an increase of 7.9% in flank pressure.

While the load distribution, the misalignment in tooth contact, and the tooth flank pressure are negatively influenced by the sequential mesh sequence, the effects on the first order of the transmission error between the sun and the planet carrier are positive. Due to the time-shifted mesh stiffness of the individual sun-planet meshes, a more uniform overall stiffness between the

sun and the planet carrier results.

## Influence of External Loads and Misalignments

The modeling of the planet carrier without external forces of the following helical gear stage is a simplification. For this reason, in the next modeling step a load-related displacement of the carrier is applied by displacing the output-side bearing position of the planet carrier in the direction of the radial force of the helical gear stage by  $\Delta x = 10 \mu\text{m}$ . Thus the effects and interactions of an additional misalignment of the planet carrier can be analyzed and evaluated in a differentiated way. Afterwards the helical gear stage is included in the simulation model instead of the static misalignment of the carrier.

**Tilted Planet Carrier.** The results with a misaligned planet carrier are shown in Figure 9 and Figure 10 with an otherwise unchanged simulation model. The mean torque sharing factor  $TSF_{p,mean}$  is not influenced by the misaligned planet carrier, see Figure 9 top left. Compared to the results without a misaligned planet carrier, it can be seen that the dynamic torque sharing

with a stiff sun shaft bearing is subject to higher fluctuations, see Figure 7 and Figure 9. The radial sun displacement shows a continuous increase of the radius with increasing planet pin position error. With a flexible sun shaft bearing and a planet pin position error of  $\varphi_{PPE,1} = 0.018^\circ$ , the mean radius of the sun shaft trajectory is  $r_{dyn,Sun,soft} \approx 31.8 \mu\text{m}$ , whereas with a stiff bearing it is only  $r_{dyn,Sun,stiff} \approx 16.8 \mu\text{m}$ . The center of the circular trajectory of the sun is moved due to the displacement of the carrier but remains almost completely in one position during the speed run-up.

The displacement of the bearing position of the planet carrier causes a tilting of the planet carrier and the planet gears inside it. During one revolution of the carrier, each planet performs a wobble due to this misalignment. This multi-dimensional movement becomes visible in the variation of the resulting lead angle deviation  $f_{H\beta}$  in the sun-planet meshes, see Figure 10 left. Here, the mean value of the lead angle deviation in the results without carrier misalignment is comparable to those with carrier misalignment, so that only the range of fluctuation due to the wobble increases. The lead angle deviation oscillates with the first rotational order of the planet carrier around the respective mean value, whereby higher frequency oscillations from the interaction of the tooth mesh with the system are superimposed. The maximum tooth flank pressure is also influenced by the higher misalignment in the tooth contacts. It increases by 4.2% at the maximum planet pin position error and a stiff sun shaft bearing on the affected planet compared to the simulation with an ideal carrier position. The results show that a flexible sun shaft bearing can almost compensate the effects of a planet pin position error on the tooth flank pressure, see Figure 10.

The evaluation of the transmission error shows an increase in the excitation between sun and planet carrier for all simulation points compared to the results with an ideal positioned carrier. Especially with a small planet pin position error of  $\varphi_{STE,1} = 0.003^\circ$ , the effect of the planet carrier misalignment with an increase in excitation of up to 125% in case of a stiff sun shaft bearing

is significantly high. For larger planet pin position errors, the additional influence of the carrier displacement is lower, see Figure 10 right.

In summary, this means that a misalignment of the planet carrier leads to multi-dimensional misalignments in the form of a wobble of the planet gears. Nevertheless, in case of a planet pin position error, a displacement situation is more optimal for the most heavily loaded planet. The bearing stiffness of the sun shaft bearing determines the resulting additional loads in the overall system.

**Overall System with Helical Gear Stage.** After the influences of a carrier displacement in combination with a sequential mesh sequence have been shown, the results are analyzed in this section under consideration of the influence of the helical gear stage, see Figure 4. The previously applied carrier displacement is removed so that the load-related displacement of the planet carrier is applied due to the forces acting in the helical gear stage. In addition, the excitations of the helical gear stage and the interaction with the planetary

gearbox are simulated.

The results of the variation of the planet pin position error are shown in Figure 11 and Figure 12. The mean values of the torque sharing factors are slightly increased compared to the statically misaligned carrier, compare Figure 9 and Figure 11. However, the range of variation increases so that the maximum torque sharing factor of the first planet increases by  $\Delta TSF_{max,flex} = 0.171$  for a flexible and by  $\Delta TSF_{max,stif} = 0.186$  for a stiff sun shaft bearing without planet pin position error. In combination with a planet pin position error of  $\varphi_{PPE,1} = 0.018^\circ$ , the increases are larger with  $\Delta TSF_{max,flex} = 0.493$  for the flexible and  $\Delta TSF_{max,stif} = 0.206$  for the stiff sun shaft bearing, see Figure 11 left. Overall, the highest loaded planet transmits up to 213.7% of the ideal torque due to the planet pin position error and the interaction with the helical gear stage.

This means that the excitation and the load-induced carrier misalignment of the helical gear stage has a reinforcing effect on the influence of the planet pin position error. Furthermore, the maximum and average torque sharing

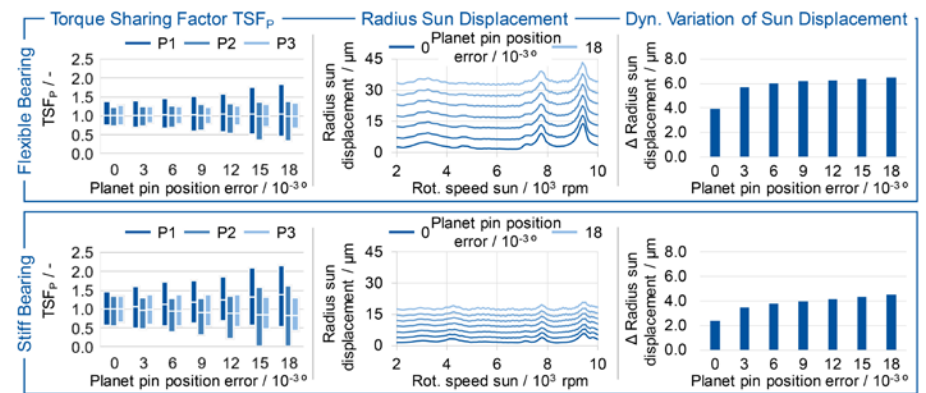

Figure 11 Torque sharing and sun displacement in the overall system.

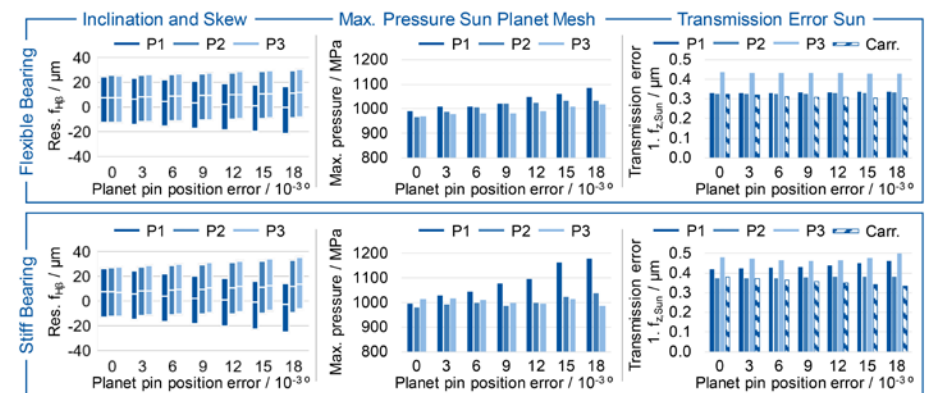

Figure 12 Sun-planet displacement and operational behavior in the overall system.

factors are lower with a flexible sun shaft bearing than with a stiff sun shaft bearing. The differences between the two planets 2 and 3 can be explained by the angular offset of the planets in the carrier and the excitation of specific resonance frequencies that occur only momentarily. The rotational position of the carrier at the time when the highest resonance excitation occurs thus determines the maximum effects on the individual planets.

The displacement of the sun shaft over one revolution of the carrier describes not a circle with a constant radius but with a varying radius. The mean radius of the movement increases with increasing planet pin position error and becomes larger overall in comparison to the modeling without a helical gear stage, see Figure 11. In addition, at  $n_{Sun}=7,800$  rpm and  $n_{Sun}=9,400$  rpm more significant peaks in the radial displacement are visible. The dynamic radius variation of the sun displacement, which results from the additional forces of the helical gear stage, increases up to 285% compared to the simulation with a statically misaligned carrier. Even with a planet pin position error of  $\varphi_{PPE,1}=0.003^\circ$ , the dynamic fluctuation of the radius due to the non-ideal circular motion is significant. Overall, the dynamic fluctuation of the sun's displacement is higher with a flexible sun shaft bearing than with a stiff one, see Figure 11 right.

The compensating movement of the sun shaft, as well as the load-induced displacement of the planet carrier lead to a higher dynamic misalignment in tooth contact. As already described in the previous section, the carrier displacement affects the first rotational order of the planet carrier in form of an oscillation of the misalignment components in the tooth contact. The forces of the helical gear stage acting on the planet carrier double these dynamic oscillations in comparison to the consideration of the only misaligned carrier, see Figure 12 left.

The average amounts of the resulting lead angle deviation are less influenced by the consideration of the helical gear stage. Here it can be seen once again that a flexible bearing of the sun shaft has no significant influence on

the average displacement that occurs in the tooth contact. Rather, it reduces the compensating forces required to achieve the optimum radial sun movement for the planet affected by the planet pin position error. In turn, the lower forces required result in lower maximum pressures. The differences in the pressure in the first sun-planet mesh without planet pin position error between flexible and stiff sun shaft bearing are still small. The pressure increase with a planet pin position error of  $\varphi_{PPE,1}=0.018^\circ$ , and a stiff bearing compared to a flexible bearing is 8.6%. If only the stiff bearing is considered, the pressure increase due to the planet pin position error of  $\varphi_{PPE,1}=0.018^\circ$  is 18.2%, see Figure 12. Compared to the simulation with a misaligned carrier, the maximum pressure in the first sun-planet mesh is 3.7% higher with a planet pin position error of  $\varphi_{PPE,1}=0.018^\circ$ .

When analyzing the transmission error, a lower dependence of the amplitude on the planet pin position error is visible due to the helical gear stage, see Figure 12 right. Furthermore, the excitation of the first tooth mesh order of the transmission error between sun and carrier is higher than in the simulation without helical gear stage and with the misaligned carrier. The transmission error between sun and carrier is therefore influenced by the tooth mesh orders of the following helical gear stage.

Altogether, the necessity of an integrated system modeling approach under consideration of the local misalignment conditions in the tooth contact of planetary gearboxes is clarified. The mesh sequence, the bearing stiffness of the sun shaft as well as a manufacturing-related planet pin position error have significant influences on the torque sharing and thus the increase of the tooth flank pressure and the dynamic transmission error. A comprehensive evaluation of the operational behavior of planetary gearboxes cannot be made with sufficient accuracy using simplifying methods.

## Conclusion

The simulation of the operational behavior of planetary gearboxes under consideration of the load-induced interactions of the components and

possible manufacturing deviations is challenging due to the dynamic displacement behavior of planetary gear stages. Within the research project "Concept ELV,"<sup>2</sup> an electrically driven rear axle for a heavy-duty distribution truck is being developed and examined with regard to its operational behavior.

The designed planetary gearbox is examined in four different model configurations with regard to the effects of a planet pin position error. First, the difference between a symmetrical and a sequential mesh sequence is considered. In the next step, a displacement of the planet carrier, which would occur in the real system due to the forces acting from the subsequent helical gear stage, is specified. Even a slight displacement of the carrier at one bearing position causes a multi-dimensional displacement of the planet gears, which thus execute a wobbling motion over one carrier revolution. This results in a higher maximum torque sharing factor as well as a higher resulting misalignment in the sun-planet mesh. This leads to higher tooth flank pressures and a higher excitation. The influence of the bearing stiffness of the sun shaft is considered. Here, as with the model configurations before, it can be seen that a more flexible sun shaft bearing has positive effects on the investigated parameters of the operational behavior.

Finally, a helical gear stage, which in the power flow follows the planetary gear stage, is also included in the simulation model. The effects of the planet pin position error are increased by the load-induced displacement caused by the forces of the helical gear stage acting on the planet carrier. Thus the maximum torque sharing factor is  $TSF_{max}=2.137$  and can be reduced to  $TSF_{max}=1.872$  with a more flexible sun shaft bearing.

The presented method offers a possibility for the quantitative evaluation of the operational behavior of integrated transmission systems. The interactions between manufacturing deviations and load-induced displacements can be simulated. In addition, the FE-based modeling of tooth contacts ensures a high quality of mesh stiffness calculation.

For further development of the method,

the calculation of the local loss energy on the tooth flank and thus an efficiency analysis of an overall system under consideration of the dynamic displacement behavior is possible. In order to evaluate the load-carrying capacity, the quantitative evaluation of the tooth root stress is possible as an extension in addition to the already available pressure calculation. Furthermore, a validation of the simulation model must be performed with experimental investigations. **PTE**

*Acknowledgement. The authors gratefully acknowledge financial support by the Federal Ministry for Economic Affairs and Energy for the achievement of the project results.*

### For more information.

Questions or comments regarding this paper? Contact Christian Westphal at [c.westphal@wzl.rwth-aachen.de](mailto:c.westphal@wzl.rwth-aachen.de).

### Bibliography

1. Klocke F.; Brecher C., 2017: Zahnrad- und Getriebetechnik. 1. Aufl, München: Carl Hanser.
2. Neubauer B., 2016: Lastverteilung und Antriebsverhalten in Planetengetriebesystemen. Diss. TU München.
3. Theling J.; Brecher C. et al, 2018: Einfluss von Planetenträgerabweichungen auf die lokale Lastverteilung in Planetengetrieben. In: KISSsoft AG (Hrsg) Schweizer Maschinenelemente Kolloquium, Dresden: TUDpress, S. 29–40.
4. Gu X.; Velex P., 2012: A dynamic model to study the influence of planet position errors in planetary gears. *Journal of Sound and Vibration* 331(20): S.4554–4574.
5. Papies J., 2014: Methodik zur systematischen Analyse und Optimierung dynamischer Kraft- und Weganregungen in Planetengetrieben. Diss. Ruhr-Universität Bochum.
6. Iglesias M.; Fernandez del Rincon A. et al, 2017: Planetary transmission load sharing: Manufacturing errors and system configuration study. *Mechanism and Machine Theory* 111: S.21–38.
7. Leque N.; Kahraman A., 2017: A Three-Dimensional Load Sharing Model of Planetary Gear Sets Having Manufacturing Errors. *IOP Conf. Ser.: Mater. Sci. Eng.* 139(3): S.2290.
8. Brecher C.; Brimmers J. et al, 2019: Einfluss der dynamischen Lastverteilung in Zahnkontakten auf das Systemverhalten. In: Schlecht B. (Hrsg) Dresdner Maschinenelemente Kolloquium DMK 2019, 1. Aufl, Göttingen: sierre VERLAG - Internationaler Wissenschaftsverlag, S. 353–372.
9. Cao J., 2002: Anforderungs- und fertigungsgerechte Auslegung von Stirnradverzahnungen durch Zahnkontaktanalyse mit Hilfe der FEM. Diss. RWTH Aachen University.
10. Hemmelmann J. E., 2007: Simulation des lastfreien und belasteten Zahneingriffs zur Analyse der Drehübertragung von Zahnradgetrieben. Diss. RWTH Aachen University.
11. Wittke W., 1994: Beanspruchungsgerechte und geräuschoptimierte Stirnradgetriebe Toleranzvorgaben und Flankenkorrekturen. Diss. RWTH Aachen University

**Christian Westphal** is a research associate in the gear department at the Laboratory for Machine Tools and Production Engineering (WZL) of RWTH Aachen University. He studied industrial engineering and management with a major in automotive engineering and corporate development at RWTH Aachen University. He started his research activities in 2019 in the group "Gear Acoustics." Currently, Westphal is working on special gearings and the dynamic excitation behavior of planetary gearboxes.



**Dr.-Ing. Jens Brimmers** is the head of the gear department at the Laboratory for Machine Tools and Production Engineering (WZL) of RWTH Aachen University since June 2019. He graduated from RWTH Aachen University with master's degrees in mechanical engineering and business administration. His Phd thesis focussed on beveloid gears and topological tooth flank modifications.



**Prof. Dr.-Ing. Christian Brecher** has since January 2004 been Ordinary Professor for Machine Tools at the Laboratory for Machine Tools and Production Engineering (WZL) of the RWTH Aachen, as well as Director of the Department for Production Machines at the Fraunhofer Institute for Production Technology IPT. Upon finishing his academic studies in mechanical engineering, Brecher started his professional career first as a research assistant and later as team leader in the department for machine investigation and evaluation at the WZL. From 1999 to April 2001, he was responsible for the department of machine tools in his capacity as a Senior Engineer. After a short spell as a consultant in the aviation industry, Professor Brecher was appointed in August 2001 as the Director for Development at the DS Technologie Werkzeugmaschinenbau GmbH, Mönchengladbach, where he was responsible for construction and development until December 2003. Brecher has received numerous honors and awards, including the Springorum Commemorative Coin; the Borchers Medal of the RWTH Aachen; the Scholarship Award of the Association of German Tool Manufacturers (Verein Deutscher Werkzeugmaschinenfabriken VDW); and the Otto Kienzle Memorial Coin of the Scientific Society for Production Technology (Wissenschaftliche Gesellschaft für Produktionstechnik WGP).



For Related Articles Search

planetary gearboxes

at [www.powertransmission.com](http://www.powertransmission.com)



# MISSING A PIECE?

We've got you covered! Go to [powertransmission.com](http://powertransmission.com) to see what you missed in last month's issue, plus another fourteen years of back issues, industry and product news, and more!

## In last month's issue:

- Bearing Predictability
- Predictive Maintenance
- Evolving Technology of the Gearbox

... and more!

# Power Transmission Engineering

# CC-Link Partner Association

## EXAMINES TSN BENEFITS IN MANUFACTURING

Time-Sensitive Networking (TSN) is considered by industry leaders as the future of industrial communications. In effect, it is poised to bring data transfer to the next-level, enabling Industry 4.0 applications. While the adoption of TSN is still in its early stages, with future-oriented businesses picking up the pace, this technology holds enormous potential for numerous manufacturing sectors.

Thomas Burke, global strategic advisor at the CC-Link Partner Organization (CLPA), looks at how different industrial sectors can reap a multitude of benefits by leveraging TSN for industrial communications:

### 1. Simplified machine design and higher performance for the converting sector

One of the key features of TSN that can bring great benefits to manufacturers is its ability to synchronize all network devices with high accuracy, especially when used with gigabit bandwidth. As a result, it is possible to ensure deterministic communications for time-critical high-speed applications, such as motion control.

For example, when this feature is adopted in networks used in the converting industry, plants can achieve accurate synchronization between multiple axes on a machine. By being able to control the motion of many different axes simultaneously over one network, facilities can optimize product quality and production processes as well as increasing the flexibility of their architectures and machines, while simplifying the mechanical set up. The end result is reduced time for retooling and maximized product yield.

### 2. Transparency and traceability for food & beverage

Accurate and precise time synchronization, as offered by TSN technology, is also extremely important when transparency and traceability are crucial.

The success of sensitive industries, such as food & beverage, relies heavily upon key process data, which need to be monitored to ensure product quality and compliance with relevant regulations or good manufacturing practices. These data require accurate timestamps that support visibility within the network and throughout the production process, eliminating any “blind spot” where issues can grow unnoticed.

By building a fully synchronized device network, TSN can support precise timestamping for timing analysis. In this way, food & beverage facilities can rely on a high degree of traceability throughout their networks and guarantee product quality and safety.

### 3. Better quality in automotive

TSN technology, particularly when combined with gigabit bandwidth, can also push manufacturing facilities to speed up their production processes, whilst ensuring determinism. This can be particularly useful for automotive assembly plants.

These facilities are responsible for the production of a wide variety of models, each characterized by different trim levels.

Hence it is mandatory for these manufacturing systems to handle large amounts of data generated in real time during the assembly of various car parts. Only in this way, manufacturers can ensure that the different combinations of possible model variations do not slow down cycle times and the allocated parts are fitted correctly on the right models, at the right time, in a traceable manner. Automotive companies can use TSN to build production lines that ensure short cycle times, as the technology combines advanced synchronization with traffic prioritization capabilities. The latter allow the network to deliver time-critical traffic exactly when needed, while allowing less critical traffic to co-exist on the network. Consequently, total cost of ownership can be reduced, since multiple types of network can now be combined onto a single hierarchy. The end result is higher performance, lowered costs and simplified maintenance. This finally translates into better quality vehicles.



### 4. Higher levels of integration for semiconductor manufacturing

Synchronicity and traffic prioritization are also key to combining different types of process control on one network and effectively handling different recipes and activities across multiple machines and stations.

For example, TSN can support the semiconductor industry, which is characterized by numerous processing stages, all requiring process, discrete and motion control, along with integration of robots and IT systems. TSN-based networks for the sector allow businesses to mix time-critical data for high-performance, high-speed motion control with slower, less time-dependent traffic, e.g. for machine vision process monitoring. Furthermore, manufacturers are given the opportunity to integrate auxiliary systems into their process and associated networks.

Ultimately, semiconductor producers can enhance flexibility in their network architecture and in their processes.

[am.cc-link.org/en/](http://am.cc-link.org/en/)

# Schaeffler's Jeff Hemphill

ASSUMES PRESIDENCY OF SAE INTERNATIONAL

Schaeffler Vice President and Chief Technical Officer **Jeff Hemphill** is the new president of SAE International for 2021. Hemphill, whose one-year term officially began on January 20, was elected by the SAE International general membership.

Hemphill is a 23-year member of SAE International. In addition to serving on the SAE Clutch Standards Committee,

he has authored and organized various SAE International technical papers, served on meeting panels, presented at SAE International conferences, and participated in and organized sponsorship of SAE International's North American International Powertrain Conference since its inception.

"SAE has been a constant presence throughout my career," said Hemphill. "Its mission - to advance mobility knowledge and solutions for the benefit of humanity - is of critical importance during this time of rapid innovation and industry transformation. The opportunity to serve as SAE International president is a tremendous honor for me, and I am looking forward to an exciting year."

As chief technical officer for Schaeffler in the Americas, Hemphill is responsible for research and new product development for automotive transmission, engine and chassis applications as well as industrial components and systems. To date, Hemphill has had nearly 80 patents filed or issued.

A 31-year veteran of the automotive industry, Hemphill started his career at Schaeffler as a machinist and co-op student while earning a Bachelor of Science degree in mechanical engineering from The University of Akron. He also earned an Executive Certificate in Strategy and Innovation from the Massachusetts Institute of Technology.

[www.sae.org/about/leadership](http://www.sae.org/about/leadership)



## Nidec Corporation

TO ACQUIRE MITSUBISHI HEAVY INDUSTRIES MACHINE TOOL CO., LTD.

Nidec Corporation has announced it will acquire Mitsubishi Heavy Industries Machine Tool Co., Ltd.

Nidec has been actively engaged in manufacture, sales and services associated with reduction gearboxes and pressing machines through its subsidiary, Nidec-Shimpo Corporation. After completion of the acquisition, Mitsubishi Heavy Industries Machine Tool will become the Nidec-Shimpo's third main business. Furthermore, the



company expects to utilize Mitsubishi Heavy Industries Machine Tool's technology for its future insourcing plan.

Nidec is expecting further demand increase for E-Axle, the electric vehicle traction unit that Nidec is most focused on at present. They aim to expand the sales of this product which combines a motor, an inverter and a reducer, it therefore imperative to strengthen manufacturing capabilities of gears, the core component of the traction unit.

Mitsubishi Heavy Industries Machine Tool started its business in 1936 for manufacturing of lathe in Hiroshima, Japan. Since then, Mitsubishi Heavy Industries Machine Tool has been a group company of Mitsubishi Heavy Industries and has grown its business, while supporting Japanese manufacturing for many years. Mitsubishi Heavy Industries Machine Tool, which designs, manufactures and sells machine tools, cutting tools and related products and provides after-sales services for the products, owns highly professional personnel in addition to its long-nurtured technologies. Mitsubishi Heavy Industries Machine Tool has products related to automotive transmissions and reducers businesses, such as a gear cutting machine and a gear grinding machine with high accuracy and efficiency. The company has top market share in Japan with this product. The company also has laser and semiconductor manufacturing equipment with unique cutting-edge technologies.

After this acquisition is completed, Nidec has a view of further expansion of machine tool business with Mitsubishi Heavy Industries Machine Tool, and believes that, with necessary investment, the business will be able to play a major global role.

[www.nidec.com](http://www.nidec.com)

## EASA

OFFERS GUIDE FOR MOTOR REPAIRS

EASA has published a "Good Practice Guide" that can help end users obtain three-phase electric motor repairs and rewinds that maintain the motor's energy efficiency and reliability.



The Guide explains in practical terms industry best practice repair/rewind procedures from ANSI/EASA Standard AR100-2020: Recommended Practice for the Repair of Rotating Electrical Apparatus that apply to all three-phase electric motors, including Premium Efficiency/IE3 motors. Based on rewind studies by independent test facilities, these procedures maintain and sometimes even improve the efficiency of repaired/rewound motors.

"More than 97 percent of an electric motor's lifetime cost is for the electricity it uses to operate. Any measurable change in its efficiency can significantly affect operating costs, a big

concern for end users” said Linda Raynes, CAE, EASA president and CEO. “EASA’s Guide provides practical insights about repair/rewind procedures for end users who can rely on ANSI/EASA AR100 to evaluate repair services and providers.”

The new Guide covers best practices for inspection, testing, mechanical repair and electrical rewinds. It also explains how repair procedures can affect common types of motor losses and motor efficiency, underscoring the importance of requiring service providers to follow the repair best practices in ANSI/EASA AR100-2020.

[www.easa.com](http://www.easa.com)

## QuesTek

AWARDED MATERIAL DEVELOPMENT FUNDING FOR ENERGY APPLICATIONS

QuesTek Innovations LLC recently announced that it was awarded \$1.2 Million in funding from the U.S. Department of Energy’s Advanced Research Projects Agency-Energy (ARPA-E). The funding will be used to design and develop a novel materials solution for next-generation turbine blade alloys and compatible coating systems. QuesTek will design a system of functionally-graded Niobium-based alloys suitable for Additive Manufacturing and that will be capable of sustaining high temperature operation and thus increasing fuel efficiency.

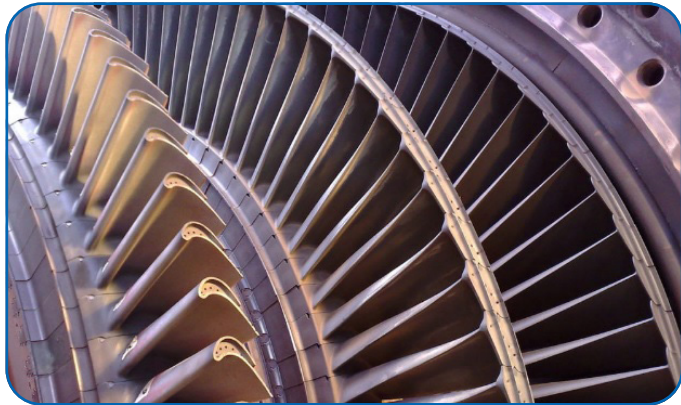

Dr. Dana Frankel, QuesTek’s manager of design and product development, stated “Designing a new turbine material with significantly better performance than current nickel-based superalloys is one of the biggest challenges facing the field of materials science today.” She added, “We’re excited for this opportunity to apply our proven computational materials design approach to develop a new refractory turbine alloy, paving the way for a step-change in turbine engine performance and efficiency.”

QuesTek will apply its Integrated Computational Materials Engineering-based models and extensive experience in design of superalloys, refractory alloys, high entropy alloys, and coatings to design a printable niobium-based multi-material alloy system. Concurrent design of material and component, with the goal of accelerating adoption of the designed materials into next-generation engines, will be achieved by teaming with leading turbine engine OEM Pratt & Whitney to define aerospace requirements, perform component design,

and guide testing and qualification. Furthermore, the project team includes NASA Jet Propulsion Laboratory for AM process development, and the University of Minnesota for coating development.

QuesTek received this competitive award from ARPA-E’s Ultrahigh Temperature Impervious Materials Advancing Turbine Efficiency (ULTIMATE) program, to develop and demonstrate ultrahigh temperature materials that can operate in the high temperature and high stress environments of a gas-turbine blade.

This effort directly addresses the need to improve gas turbine efficiency for aerospace and energy applications (e.g., ground-based industrial gas turbines), critical for increasing fuel economy and decreasing carbon emissions. Engine efficiency is fundamentally determined by maximum cycle temperature, and thus scales directly with the operating temperature. However, current state-of-the-art superalloys have limited high-temperature stability.

[www.questek.com](http://www.questek.com)

## Auburn Bearing

ACQUIRES AUROTEK TSB

As of February 1, 2021, Auburn Bearing & Manufacturing Inc, an American-based designer and manufacturer of thrust bearings, custom bearings and precision components, is excited to announce that it has acquired the assets of Aurotek TSB, Inc.

Aurotek TSB, Inc. is specialized in the production of precision thin section bearings for a broad array of industries. These bearings are used in a variety of applications, namely, for use in defense weapon systems, medical equipment, radar equipment, aerospace guidance systems, packaging machines, industrial assembly machines, and robotics for security, medical, nuclear and defense systems.

## Auburn Bearing & MANUFACTURING

*Made in the USA since 1898*

Peter Schroth, president of Auburn Bearing & Manufacturing, notes that this acquisition aligns with the company’s strategy to expand their product offerings to include American-made precision radial bearings, along with current thrust ball and roller bearings, in low- to mid- volume production runs and with reasonable lead times.

Aurotek TSB was founded by Dr. Don Cancelmo, who spent his entire career working in the thin section bearing industry. Auburn Bearing & Manufacturing had been a supplier of rings and bearing components to the company since 2011.

Previously located in Herkimer NY, the operations and assets of Aurotek TSB will be moved to Macedon, NY, where the business will continue to operate within the Auburn Bearing & Manufacturing facility, located at 4 State Route 350, Macedon, NY 14502.

[www.auburnbearing.com](http://www.auburnbearing.com)

# Poggi

CONTINUES SUCCESSFUL GREEN AND SUSTAINABLE JOURNEY WITH PHOTOVOLTAIC SYSTEM

Poggi Trasmissioni Meccaniche Spa continues to provide green solutions and focus on renewable energy. The photovoltaic system installed last winter by Siat Energy has recorded performances in line with expectations, proving to be an asset of strategic importance for the company's future. During the first operation year, the plant recorded a high-level performance, producing a total energy of 402,383 kWh and reducing the emission into the atmosphere of 233.4 tons of CO<sub>2</sub>.



The plant, consisting of 1,383 modules of 285 Wp each and with a nominal power of 394,155 kWp, recorded performances in line with the expectations and estimates of engineers and technicians of Siat Energy, a leading player in the sector, who oversaw its development in all its phases, from the feasibility study to the technical implementation. From 3-13-2020 (working start) until 12-31-2020, the monthly comparison between expected and actual production marked very slight differences, in some cases negative, in other cases positive as in March, April and September when the actual produced energy exceeded the estimated one.

Altogether, the expected project values were met with a total energy produced equal to 402,383 kWh instead of 412,538 kWh. Finally, on the environmental impact profile, important benefits arised for the entire community. The plant has reduced the emission into the atmosphere of 233.4 tons of CO<sub>2</sub>, an important figure that can be translated more effectively with the imaginary presence of a small forest of 30,470 trees.

"After these first results," said Andrea Poggi, president, "we are even more convinced of the investment made. The decision to install a photovoltaic system reflects our commitment to the environment, but at the same time our will to grow as a company. I am sure that this plant will prove to be an increasingly important and strategic asset in the coming years, capable of having a positive impact not only on sustainability but also on the entire company productivity."

[www.poggispa.com](http://www.poggispa.com)

# Portescap

BRUSHLESS DC MOTORS ACHIEVE ISO 13485 CERTIFICATION FOR RESPIRATORS

Portescap recently announced that its slotless brushless DC motors for respirators have received ISO 13485:2016 certification. Thanks to this compliance, medical device original equipment manufacturers (OEM) can be confident their motion control system has been manufactured to the highest quality standards.

Expanding on ISO 9001, this standard contains specific requirements for parts traceability and risk management activities throughout the design and development stages. It also requires process and software validations at defined intervals. Presented by independent risk management and quality compliance firm, DNV GL, ISO



13485 compliance is an important part of Portescap's quality management system and demonstrates its consistency in design, development, production, storage and distribution.

As a result of ISO 13485 compliance, OEMs can be certain that products manufactured at Portescap's 72,000-square-foot facility in Mumbai, India meet the highest standards for quality and consistency. The plant currently includes over 1,100 staff and is outfitted with machining, winding and injection molding equipment, as well as an electrostatic discharge (ESD) safe assembly facility.

[www.portescap.com](http://www.portescap.com)

# BorgWarner

AGREES TO PURCHASE GERMAN BATTERY PACK SUPPLIER AKASOL AG

BorgWarner Inc. have signed a business combination agreement ("BCA") with Akasol AG to position BorgWarner to significantly expand its commercial vehicle electrification capabilities.

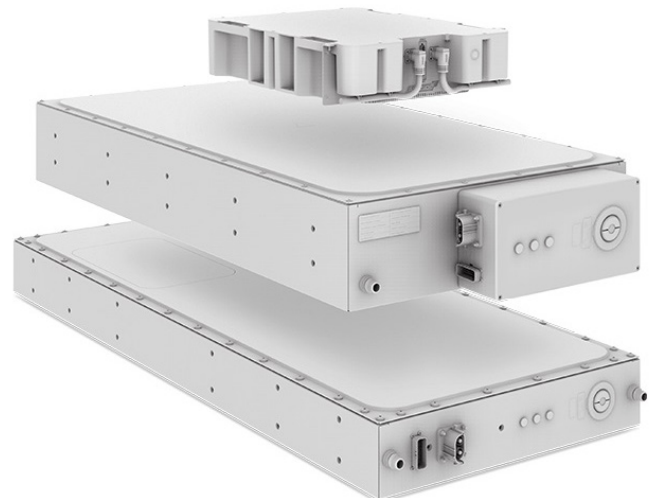

Headquartered in Darmstadt, Germany, Akasol AG designs and manufactures customizable battery packs for use in buses, commercial vehicles, rail vehicles and industrial vehicles, as well as in ships and boats. This proprietary system technology is cell-agnostic, providing a low-cost, flexible solution to world-class customers. With more than 300 full-time employees and three facilities across Germany and one facility in the United States, Akasol believes it is well positioned to capitalize on the large market opportunity across Europe and North America.

“Akasol is an excellent strategic fit as BorgWarner seeks to continue to expand its electrification portfolio and capitalize on the profound industry shift towards electrification. Akasol’s manufacturing footprint and established, in-production customer base are complementary to BorgWarner’s and would accelerate our foothold into the fast-growing commercial vehicle and off-highway battery pack market,” said Frédéric Lissalde, president and CEO of BorgWarner. “Akasol is highly-regarded as a reputable and reliable partner, and like us, they have a customer-first mentality and a culture of innovation and environmentally friendly technology leadership. We look forward to welcoming their incredibly talented team to BorgWarner.”

BorgWarner believes the acquisition would significantly strengthen its commercial vehicle and off-highway battery systems business as it continues to execute its electrification strategy. With the global, lithium-ion battery market for electric vehicles expected to grow, Akasol believes it is well positioned to meet the demand for battery systems in the global electric commercial vehicle market.

“The executive board welcomes the strategic partnership with BorgWarner, as it offers significant strategic perspectives to Akasol,” said Sven Schulz, CEO and founder of Akasol. “BorgWarner shares our vision of emission-free mobility, and with joint forces, we will expand Akasol’s technology and market leadership for high-performance battery systems.”

[www.borgwarner.com](http://www.borgwarner.com)

## Regal

### TO COMBINE WITH REXNORD’S PMC SEGMENT

Regal Beloit Corporation and Rexnord Corporation have announced that they have reached a definitive agreement whereby Rexnord will separate its Process & Motion Control (“PMC”) segment by way of a tax-free spin-off to Rexnord shareholders and then immediately combine it with Regal in a Reverse Morris Trust (“RMT”) transaction. Regal shareholders will own 61.4% and Rexnord shareholders will own 38.6% of the combined entity (“New Regal”), before a potential dividend to Regal shareholders and a corresponding ownership adjustment to Rexnord shareholders, sized at closing to ensure that RMT ownership requirements are met. Rexnord



shareholders will continue to own 100% of the businesses’ Water Management platform.

With the addition of PMC, Regal’s 2020 pro forma revenue was approximately \$4.1 billion with Adjusted EBITDA of \$740 million, excluding \$120 million in annualized cost synergies expected to be achieved by year three after closing. The pro forma 2020 EBITDA margin was approximately 18%.



The transaction combines Regal and PMC’s best-in-class power transmission portfolios to drive innovation in industrial power transmission and motion control solutions through superior engineering, technology, and manufacturing capabilities. PMC is a world-class provider of specialized, highly-engineered power transmission components and solutions, with a strong portfolio of Industrial Internet of Things (“IIoT”) solutions. The transaction expands Regal’s portfolio, customer reach, and product diversity while creating shareholder value through enhanced growth and substantial cost synergies.

“This transformative combination brings together two highly complementary businesses, creating a premier provider of power transmission products, poised to deliver enhanced value for our customers, associates, and shareholders,” said Regal CEO, Louis Pinkham. “Combining with PMC accelerates our transformation momentum and is an important step towards our vision to accelerate profitable growth. We believe this transaction will create meaningful value for customers by providing comprehensive solutions across the entire industrial drive train, increased portfolio and reach, and an enhanced presence in diverse and attractive end markets and geographies. Shareholders will benefit from compelling value creation and financial benefits, including enhanced growth, cost synergy-driven margin expansion, attractive ROIC, and earnings accretion.”

“We have long admired PMC’s products and capabilities, highly-regarded brands, and talented team. Importantly, Regal and PMC are a terrific cultural fit with a shared commitment to integrity, customer success, continuous improvement, and a passion to win. We are confident these shared values and complementary business structures will help facilitate a seamless transition and fuel our continued success,” he added.

Todd Adams, chairman, president and CEO of Rexnord, commented, “This transaction provides clear and compelling value for Rexnord shareholders through ownership in a combined company with enhanced scale and significant growth opportunities. Regal is committed to investing in the continued growth of its power transmission business, and we are confident the PMC platform and team are a perfect fit to accelerate their strategy. Rexnord’s Water Management business will be well-positioned to continue to drive differentiated growth as a standalone business aligned around its distinct competitive advantages and market dynamics.”

[www.regalbeloit.com](http://www.regalbeloit.com)

[www.rexnord.com](http://www.rexnord.com)

# Atlanta Drive Systems

OPTIMIZES GEAR RACK ASSEMBLY WITH DIGITAL TOOLS

The positioning accuracy of a rack and pinion drive is dependent on the cumulative pitch error inherent in each gear rack used. For long travel lengths, this cumulative pitch error can add up very quickly and dramatically affect the positioning accuracy of the axis.

Atlanta now offers “digital” gear racks and a smartphone app that when used together can optimize the assembly of a multi gear rack system to minimize the cumulative pitch error and maximize positioning accuracy over the complete axis travel length.

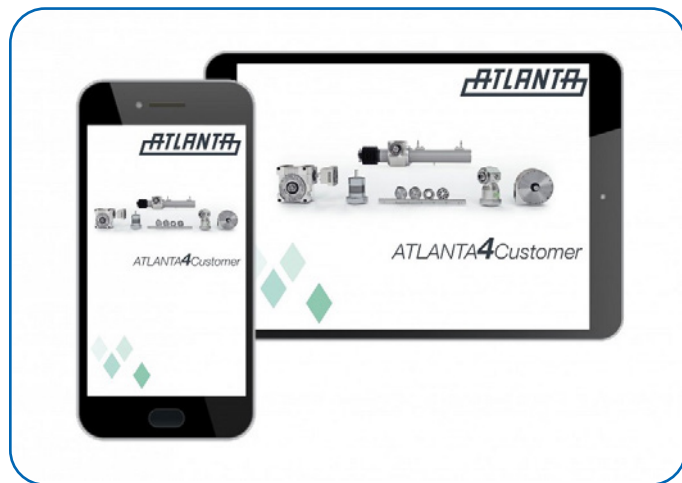

A “digital” gear rack has a 2D matrix code (similar to a QR code) and serial number marked directly onto it to encode the gear rack production and measurement information. This transforms an ordinary gear rack into a “digital” gear rack with smart drive technology built into it.

The “digital” gear rack can now be used with the ATLANTA4Customer smartphone app to create an assembly map. The app allows a customer to scan the 2D matrix code on the gear racks and download the encoded manufacturing information from the Cloud. This information can be used to create an assembly map for the gear racks.

For a desired travel axis length, a series of gear racks would be set out to be scanned. Each gear rack would be scanned into the smartphone app, which would collect all of the gear rack pitch error information into the mapping tool in the app. Once all of the gear racks have been scanned, the smartphone app would sort the gear rack assembly order to achieve the minimum cumulative pitch error and maximum positioning accuracy for the total axis length.

This can be very helpful for machines with longer travel lengths, allowing for significant machine performance and precision improvements with increased assembly efficiency using standard, off-the-shelf Atlanta rack and pinion products.

[www.atlantadrives.com](http://www.atlantadrives.com)

# Timken’s Philadelphia Gear

EXPANDS RELATIONSHIP WITH U.S. NAVY

The Timken Company is expanding upon its decades-long relationship with the United States Navy. Huntington Ingalls Industries – Newport News Shipbuilding (HII-NNS) recently awarded a contract to Timken’s Philadelphia Gear to supply the main reduction gears (MRGs) for the future USS Doris Miller (CVN-81) aircraft carrier.

Philadelphia Gear will provide engineering support for the MRGs at its technical center in King of Prussia, Pa., and will perform manufacturing and assembly at its marine center of excellence in Santa Fe Springs, Calif. The cumulative value of the contract is in excess of \$100 million, with delivery of the MRGs scheduled for 2025-2026. Once commissioned, the Doris Miller will serve in the Navy’s Fleet into the 2080s.



Computer-generated image courtesy of the U.S. Navy.

“Philadelphia Gear has built essential gear systems for a variety of classes of U.S. Navy ships over the years, and we’re honored to continue that relationship by supplying the MRGs for CVN-81,” said Carl Rapp, Timken group vice president. “We thank HII-NNS for entrusting us with this critical role for the U.S. Navy’s cornerstone platform.”

The Doris Miller is the first aircraft carrier named for an enlisted sailor and the first named for an African-American. It’s part of the Gerald R. Ford carrier class of 1,100-foot-long, 100,000-ton ships. Considered the centerpiece of the Navy’s Carrier Strike Groups (CSGs), each Gerald R. Ford class ship is able to accommodate 75+ aircraft.

Timken acquired Philadelphia Gear, a recognized leader in high-performance gear drives, components and related services, in 2011. With over 128 years of power transmission design experience, Philadelphia Gear offers world-class expertise in the service and manufacture of power transmission equipment.

[www.timken.com](http://www.timken.com)

## CALL FOR PAPERS!

Are you sitting on an idea for a technical paper but wondering where to present it? Do you have one already written, sitting on your desk, gathering machine dust?

How about *Power Transmission Engineering*? We are always looking for gearing- and power transmission component-relevant technical papers for publication in the magazine and in its digital version. Having your work appear in *Power Transmission Engineering* guarantees you an audience of the most experienced and discriminating industry players. You say your work has not been peer-reviewed? Not a problem, as we are lucky—and thankful—to have on-hand some of the most experienced and brilliant minds in the industry—our technical editors. So if your work “passes muster” and is published, you’ll know you were reviewed by the best—and most demanding.

Chances are you’ll be creating the paper under the auspices of the company for whom you work or own, or for one of the various industry-relevant associations. That means they as well will bask in the reflected glory that accrues with publication in *Power Transmission Engineering*.

For publication guidelines and more information, please contact Jack McGuinn at [jmguinn@powertransmission.com](mailto:jmguinn@powertransmission.com).

### AGMA

Pages 29, 40-41  
[MotionPowerExpo.com](http://MotionPowerExpo.com)

### Andantex USA

Page 35  
[www.andantex.com](http://www.andantex.com)

### B&R Machine and Gear

Page 38  
[www.brgear.com](http://www.brgear.com)

### BDH Belts

Page 38  
[www.bdhbelts.com](http://www.bdhbelts.com)

### Beyta Gear Service

Page 2  
[www.beytagear.com](http://www.beytagear.com)

### Bonfiglioli USA

Page 13  
[www.bonfiglioli.com/usa/en/Bonfiglioli-ecommerce](http://www.bonfiglioli.com/usa/en/Bonfiglioli-ecommerce)

### Brother Gearmotors

Inside Front Cover  
[BrotherGearmotors.com](http://BrotherGearmotors.com)

### Circle Gear

Page 10  
[www.circlegear.com](http://www.circlegear.com)

### Designatronics

Pages 9, 34  
[www.sdp-si.com](http://www.sdp-si.com)

### Diequa Corp.

Pages 18, 39  
[www.diequa.com](http://www.diequa.com)

### Force Control industries

Page 17  
[www.forcecontrol.com](http://www.forcecontrol.com)

### JIE USA

Page 37  
[www.jie-drives.com](http://www.jie-drives.com)

### Lafert North America

Page 16  
[www.lafertna.com](http://www.lafertna.com)

### McInnes Rolled Rings

Page 32  
[www.mcinnesrolledrings.com](http://www.mcinnesrolledrings.com)

### Molon Motor and Coil Corp.

Page 14  
[www.Molon.com](http://www.Molon.com)

### NES Bearing Co., Inc.

Page 23  
[www.nesbearings.com](http://www.nesbearings.com)

### Nordex Inc.

Page 39  
[www.nordex.com](http://www.nordex.com)

### PBC Linear

Outside Back Cover  
[pbclinear.com](http://pbclinear.com)

### Quality Bearings & Components

Page 9  
[www.qbcbearings.com](http://www.qbcbearings.com)

### Quicksilver Controls

Page 2  
[www.QuickSilverControls.com](http://www.QuickSilverControls.com)

### RBI Bearing Inc.

Page 5  
[www.rbibearing.com](http://www.rbibearing.com)

### Regal Beloit

Page 7  
[Regalbeloit.com/IRONMAN](http://Regalbeloit.com/IRONMAN)

### SDP/SI

Pages 9, 34  
[www.sdp-si.com](http://www.sdp-si.com)

### SEW-Eurodrive

Inside Back Cover  
[www.seweurodrive.com](http://www.seweurodrive.com)

### SIPCO i.Mak

Page 39  
[www.sipco-imak.com](http://www.sipco-imak.com)

### Worldwide Electric

Page 11  
[worldwideelectric.net](http://worldwideelectric.net)

### Zero-Max

Pages 3, 36  
[www.zero-max.com](http://www.zero-max.com)



# Power Transmission Engineering®

# FREE SUBSCRIPTION

20PTEALL

## Please Respond

Your response ensures that we deliver the magazine only to those who want it. It also gives us the vital information we need to serve you best.

- YES** I want to receive/continue to receive **Power Transmission Engineering**
- NO** Thanks anyway, but I don't need the world's best publication on mechanical components.

Name \_\_\_\_\_ Job Title \_\_\_\_\_  
(please print)

Signature \_\_\_\_\_ Date \_\_\_\_\_  
(required)

## How would you like to receive Power Transmission Engineering?

- PRINT Version (Verify mailing info below)
- DIGITAL Version (E-mail required)
- BOTH Print AND Digital (E-mail required)

E-mail \_\_\_\_\_ \*

**\*You can OPT OUT of your e-mail subscription at any time.**

## How is THIS LOCATION involved with power transmission products? (Check all that apply)

- WE MAKE power transmission products
- WE BUY power transmission products
- WE SELL power transmission products (Distributors, sales reps, etc.)
- WE DESIGN products with power transmission components in them
- Other (please describe) \_\_\_\_\_

What is your company's principal product or service? \_\_\_\_\_

\_\_\_\_\_

## MAILING INFORMATION

NAME:

JOB TITLE:

COMPANY:

ADDRESS:

- Check if this is a home address

CITY:

STATE/Province:

ZIP/Postal Code:

PHONE:

FAX:

**If your label is incorrect or incomplete, please update it above!**

**FAX to 1-847-437-6618**

SCAN to: [subscribe@powertransmission.com](mailto:subscribe@powertransmission.com)

# An Inside Look at Bell's EDAT System

Matthew Jaster, Senior Editor

**Bell's Electrically Distributed Anti-Torque (EDAT) is Bell's latest commercial innovation, unveiled in February 2020. The EDAT system is composed of four small fans within a tail rotor shroud in an offset two-by-two pattern.** Each of the rotors contains four blades, and they are powered by four separate motors with the electrical energy provided through generators driven by the turbine engines.

This innovation provides enhancements to reduction in noise pollution compared to an aircraft with a conventional tail rotor as well as lower operational and maintenance costs. Throughout the year, Bell's EDAT innovation has garnered interest as the first technology of its kind in the rotorcraft industry, challenging the norms for aircraft noise output, safety, and electrical distribution.

"We replaced conventional drive system components—gearboxes, drive-shafts, etc.—with electric motors and electric generators that power the motors," said Eric Sinusas, director, development programs at Bell. "We took an existing helicopter, the Bell Model 429, and we stripped out all the classic drivetrain components that power the tail rotor and we replaced it with the EDAT system."

This unique electric system offers a variety of rotorcraft benefits including reduced noise pollution, enhanced safety features, and lower operating costs.

"One of the main drivers for rotorcraft noise is the tip speed of the blades—with a conventional system the tail rotor is mechanically-linked to the engine through the drivetrain," Sinusas said. "With an electrically driven propulsion system, we're able to change the speeds and control thrust by varying the speed of the electric motor driven fans. As a result, we can reduce the tip speed in most operating conditions."

This results in the ability to shut down the tail rotor completely when you hit a certain forward air speed, for example. In conventional mechanical systems, the tail rotor is always spinning at 100-percent rpm.

Rotorcraft safety is another area where the EDAT system thrives.

"When the aircraft is on the ground, we can completely shut off the tail rotor," Sinusas said. "In a conventional system during warm-up or cool down, the tail rotor is going to

be running and linked to the engine. If you're an EMS operator on the side of the highway loading patients into a standard rotorcraft, the tail rotor is still running. The EDAT presents an opportunity to keep ground crews safer as they work around the vehicle."

If the aircraft loses one, two or three fans due to a mechanical failure or a bird strike, the pilot can still get the rotorcraft to the ground safely with the EDAT system. Operating costs also go down by removing the gears, bearings, couplings, and any lubricated components that require additional maintenance.

"Our team at Bell is focused on innovation," Sinusas said. "Research and development is something we take very seriously and we're investing strongly in these areas. The team



Bell's EDAT system

continues to design, build and fly new innovative solutions by applying a unique approach to meet the needs of current and future customers."

Bell rebranded its name back in 2018, dropping "Helicopter" to reflect that the organization is evolving into something much more than just a helicopter company. With an emphasis on innovation and technology, it will be interesting to see where the organization pushes the boundaries of flight in the future. **PTE**

To learn more about Bell's innovative EDAT system, visit [www.bellflight.com](http://www.bellflight.com)



## Stressed out?

Juggling too many motion control projects while trying to keep up with new technology can be overwhelming! It's time to contact an SEW automation specialist.

Our exclusive software modules empower you to perform complex automation very simply and **without** experience. Or, we can provide a complete package, including project planning, software, components, commissioning, and worldwide support.

Either way, relax... We got this!



# Motion Control Solutions from Extra Large to Extra Small

**XL**  
SIZE

Configure Today at [pbclinear.com](http://pbclinear.com)  
and Make Your Tailored Solution!



**MUK Series**  
[bit.ly/Config-MUK](http://bit.ly/Config-MUK)

**MTB Series**  
[bit.ly/Config-MT](http://bit.ly/Config-MT)

**PLA Series**  
[bit.ly/Config-PL](http://bit.ly/Config-PL)

**UG Series**  
[bit.ly/Config-UG](http://bit.ly/Config-UG)

**Compact Series**  
[bit.ly/Config-Compact](http://bit.ly/Config-Compact)

**ML Series**  
[bit.ly/Config-ML](http://bit.ly/Config-ML)

**LSM Series**  
[bit.ly/Config-LeadScrew](http://bit.ly/Config-LeadScrew)

**XS**  
SIZE



6402 E. Rockton Road, Roscoe • Illinois 61073 USA  
+1.800.962.8979 • [pbclinear.com](http://pbclinear.com)



Request a FREE  
product sample at:  
[bit.ly/sample-lead-screw](http://bit.ly/sample-lead-screw)