

# Power Transmission Engineering®

FEBRUARY 2017

M E C H A T R O N I C S

A MECHATRONICS  
RENAISSANCE

CHANGING  
TECHNOLOGIES,  
CHANGING  
PERSPECTIVES

## FLUID POWER

IFPE PREVIEW  
FLUID POWER CHALLENGE





# Can your gearbox go the distance?

## Optimize driveline performance with SKF bearings and more.

SKF optimizes transmission performance and reliability for manufacturers and end users alike. Using the SKF Life Cycle Management approach, we can help you

- Increase torque
- Downsize designs
- Double bearing service life
- Improve energy efficiency
- Increase reliability
- Reduce energy use

We help you reach these goals with a complete range of gearbox solutions – from upgraded SKF Explorer spherical roller bearings to commissioning, repair and remanufacturing services and much more.

For more information, visit [skf.com](https://www.skf.com).

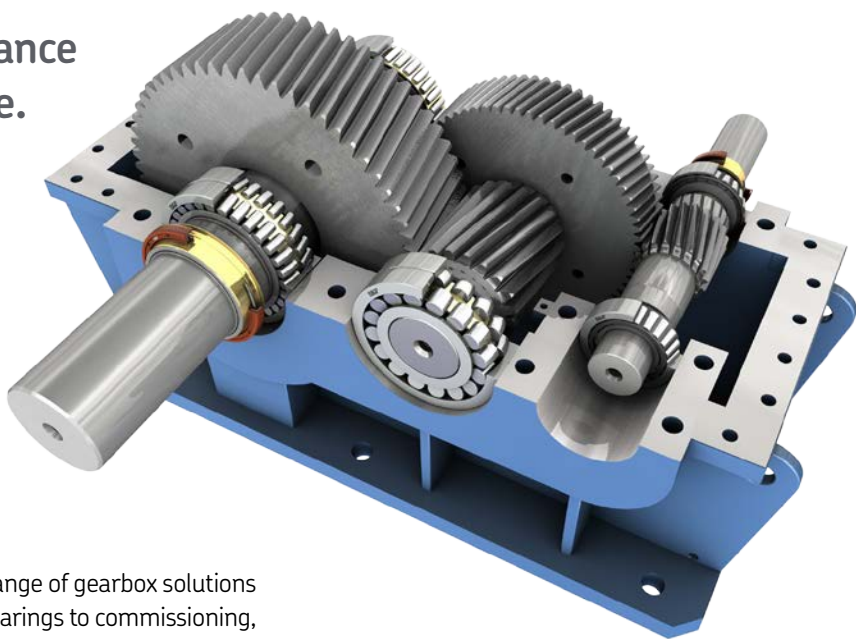

**SKF**®

# Power Transmission Engineering®

FEBRUARY 2017

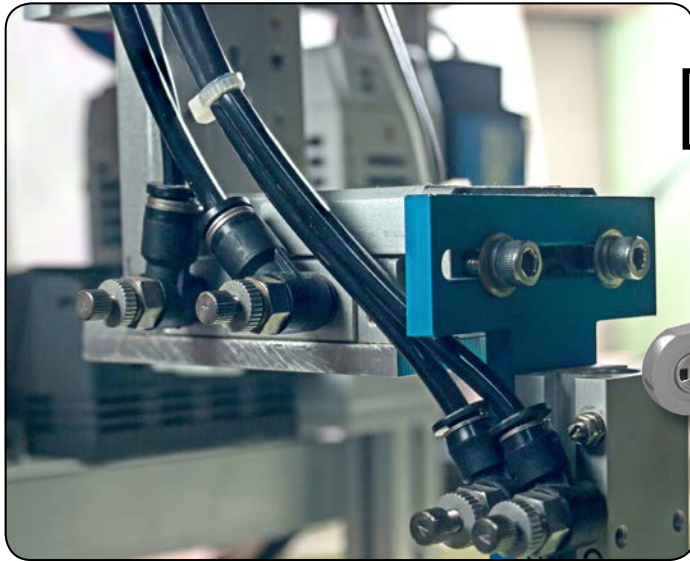

[22]



## FEATURE ARTICLES

[18] **Changing Technologies, Changing Perspectives**

A conversation with Jeff Hemphill, CTO, Schaeffler Group USA Inc.

[22] **Mechatronics — Gaining Control and Applications**

"New" technology turning heads — and profits.

[26] **Navigating Product Lifecycle Management**

How and why to implement a PLM strategy.

[30] **Hands-On Hydraulics & Pneumatics**

Action Challenge introduces students to fluid power industry.

[58] **IFPE**

Hydraulics, pneumatics, motion control and power transmission take center stage in Las Vegas.

## TECHNICAL ARTICLES

[36] **Ask the Expert**

Putting the skids to pulley slippage.

[38] **Baldor Motor Basics, Part 2**

The mystery of motor frame size  
Primer for two-speed motors

[44] **Lightweight, Highly Efficient Drive System**

New integrated drive system incorporating PM motors and brake solution — a market changer?

[50] **Defining and Predicting Housing Strength for Mounted Bearings Design**

Facilitating applications-specific selection of pillow block bearings.

Vol. 11, No. 1, POWER TRANSMISSION ENGINEERING (ISSN 2331-2483) is published monthly except in January, May, July and November by Randall Publications LLC, 1840 Jarvis Ave., Elk Grove Village, IL 60007, (847) 437-6604. Cover price \$7.00. U.S. Periodicals Postage Paid at Elk Grove Village IL and at additional mailing offices. Send address changes to POWER TRANSMISSION ENGINEERING, 1840 Jarvis Ave., Elk Grove Village, IL 60007.

Randall Publications LLC makes every effort to ensure that the processes described in POWER TRANSMISSION ENGINEERING conform to sound engineering practice. Neither the authors nor the publisher can be held responsible for injuries sustained while following the procedures described. Postmaster: Send address changes to POWER TRANSMISSION ENGINEERING, 1840 Jarvis Avenue, Elk Grove Village, IL, 60007. ©2017 Contents copyrighted by RANDALL PUBLICATIONS, LLC. No part of this publication may be reproduced or transmitted in any form or by any means, electronic or mechanical, including photocopying, recording, or by any information storage and retrieval system, without permission in writing from the publisher. Contents of ads are subject to Publisher's approval.

**SUHNER**

Transmission expert.



## Flexible shafts for special machinery

Efficient automation starts with efficient shafts.



**SUHNER MANUFACTURING, INC.**  
Rome, GA 30161  
706-235-8046  
[www.suhner.com](http://www.suhner.com)  
[info.usa@suhner.com](mailto:info.usa@suhner.com)

**SUHNER**  
EXPERTS. SINCE 1914.

# Power Transmission Engineering

VOL. 11, NO. 1

## [04] PTEExtras

Check us out — [www.powertransmission.com](http://www.powertransmission.com) — for latest videos, blog postings, social media and events

## [06] Publisher's Page

The Big Picture

## [08] Product News

R+W intros STE Safety Coupling Series; new Siemens technology controller simplifies motion control tasks

## [34] Engineering sMART

Products and services marketplace

## [54] Industry News

News and names worth noting

## [60] Calendar

**March 7-11:** IFPE 2017, Las Vegas, Nevada

**March 21-23:** AGMA 2017 Gearbox CSI, Concordville, PA  
**March 30-April 1:** AGMA-ABMA

## [62] Advertiser Index

How and where to reach every supplier in this issue.

## [63] Subscriptions

Free subscriptions, anywhere in the world.

## [64] Power Play

Now *That's* Smart Manufacturing!

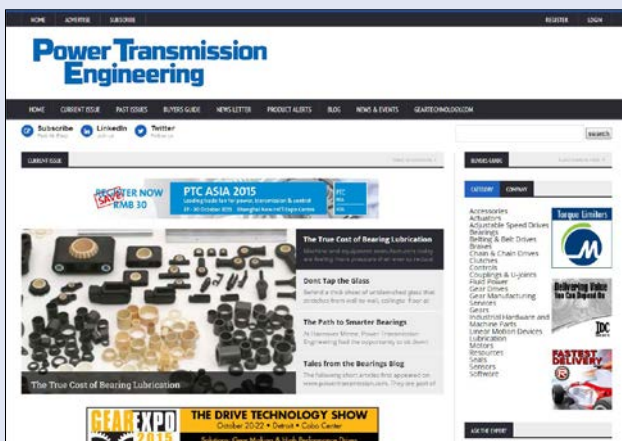

## Power Transmission Engineering

- Technical content free for everyone
- Comprehensive Buyers Guide
- The latest news

[www.powertransmission.com](http://www.powertransmission.com)



**GEAREXPO**  
**2017**  
THE DRIVE TECHNOLOGY SHOW



# WHAT DRIVES YOU

Gear Expo drives innovation. It's where power transmission and drive technology experts come to discover advancements in the gear industry. In addition, our education courses will keep you up to date on how to avoid gear and bearing failures, gearbox maintenance and lubrication.

Drive home with new insights and technology for your business.

FOR MORE INFORMATION, VISIT  
[www.gearexpo.com/pte](http://www.gearexpo.com/pte)

## NETWORKING, ON-SITE DEMONSTRATIONS, AND TOP-NOTCH EDUCATION

**JOIN THOUSANDS** of design, manufacturing and application engineering professionals as well as gear buyers and manufacturers to network and build relationships that drive profits for your company.

**EXPLORE A SOLD-OUT EXHIBIT HALL** filled with the latest equipment and machines to make your operations more efficient and your systems made to the highest quality. See them in action firsthand.

**GET NEW IDEAS** during education sessions led by industry experts who provide relevant and timely solutions to the challenges you and your team face every day.

October 24–26, 2017

Columbus, OH  
Greater Columbus Convention Center

## PTE Videos

Our *Power Transmission Engineering* video library is expanding (<http://www.powertransmission.com/videos/>). New videos recently posted include product information from Gates, Baldor, Mobil, Schaeffler and more. Submit your videos for consideration to [mjaster@powertransmission.com](mailto:mjaster@powertransmission.com).



## Automate 2017



Automate 2017 will showcase the full spectrum of automation technologies and solutions, from traditional industrial applications to cutting edge new technologies. Live show demonstrations will inform the industry on the successful integration of automation, robotics and machine vision. Keynote speakers include Andrew Winston, Markus Lorenz and **Earvin "Magic" Johnson**. For more information, visit [www.automateshow.com](http://www.automateshow.com).

Visit us at Automate 2017. *Power Transmission Engineering* will be in Booth #2565.

## PTE Library: Bearings

We've collected our database of bearing articles and product information in one place, visit <http://www.powertransmission.com/subjects/bearings/> to find information on everything from roller bearings to plastic bearings as well as purchasing and sizing and selecting practices.

## The Bearing Blog with Norm Parker

Norm Parker is the bearing technical specialist for the driveline division at General Motors LLC. Read some of his latest blog entries on the website here: [www.powertransmission.com/blog/demystifying-bearing-fit-practices/](http://www.powertransmission.com/blog/demystifying-bearing-fit-practices/).

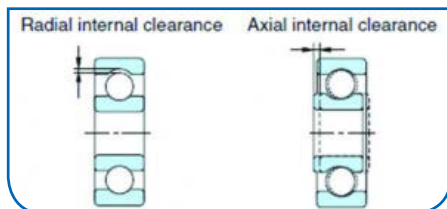

## Stay Connected



Follow us on Twitter  
[twitter.com/#!/PowerTransMag](https://twitter.com/#!/PowerTransMag)



Connect with us on LinkedIn  
[www.linkedin.com/groups/Power-Transmission-Engineering-PTE-2950055](http://www.linkedin.com/groups/Power-Transmission-Engineering-PTE-2950055)



Subscribe Online  
[www.powertransmission.com/subscribe.htm](http://www.powertransmission.com/subscribe.htm)

# Power Transmission Engineering

### Randall Publications LLC

1840 Jarvis Avenue  
Elk Grove Village, IL 60007  
Phone: (847) 437-6604  
Fax: (847) 437-6618

### EDITORIAL

#### Publisher & Editor-in-Chief

Michael Goldstein  
[publisher@powertransmission.com](mailto:publisher@powertransmission.com)

#### Managing Editor & Associate Publisher

Randy Stott  
[wrs@powertransmission.com](mailto:wrs@powertransmission.com)

#### Senior Editor

Jack McGuinn  
[jmcguinn@powertransmission.com](mailto:jmcguinn@powertransmission.com)

#### Senior Editor

Matthew Jaster  
[mjaster@powertransmission.com](mailto:mjaster@powertransmission.com)

#### News Editor

Alex Cannella  
[alex@geartechology.com](mailto:alex@geartechology.com)

#### Editorial Consultant

Paul R. Goldstein

### ART

#### Art Director

David Ropinski  
[dropski@powertransmission.com](mailto:dropski@powertransmission.com)

### ADVERTISING

#### Advertising Sales Manager & Associate Publisher

Dave Friedman  
[dave@powertransmission.com](mailto:dave@powertransmission.com)

#### China Sales Agent

Eric Wu  
Eastco Industry Co., Ltd.  
Tel: (86)(21) 52305107  
Fax: (86)(21) 52305106  
Cell: (86) 13817160576  
[eric.wu@eastcotec.com](mailto:eric.wu@eastcotec.com)

#### Materials Coordinator

Dorothy Fiandaca  
[dee@randallpublications.com](mailto:dee@randallpublications.com)

### CIRCULATION

#### Circulation Manager

Carol Tratar  
[subscribe@powertransmission.com](mailto:subscribe@powertransmission.com)

#### Circulation Coordinator

Barbara Novak  
[bnovak@powertransmission.com](mailto:bnovak@powertransmission.com)

### RANDALL PUBLICATIONS STAFF

#### President

Michael Goldstein

#### Accounting

Luann Harrold



# Your ball screw Your servomotor Our coupling

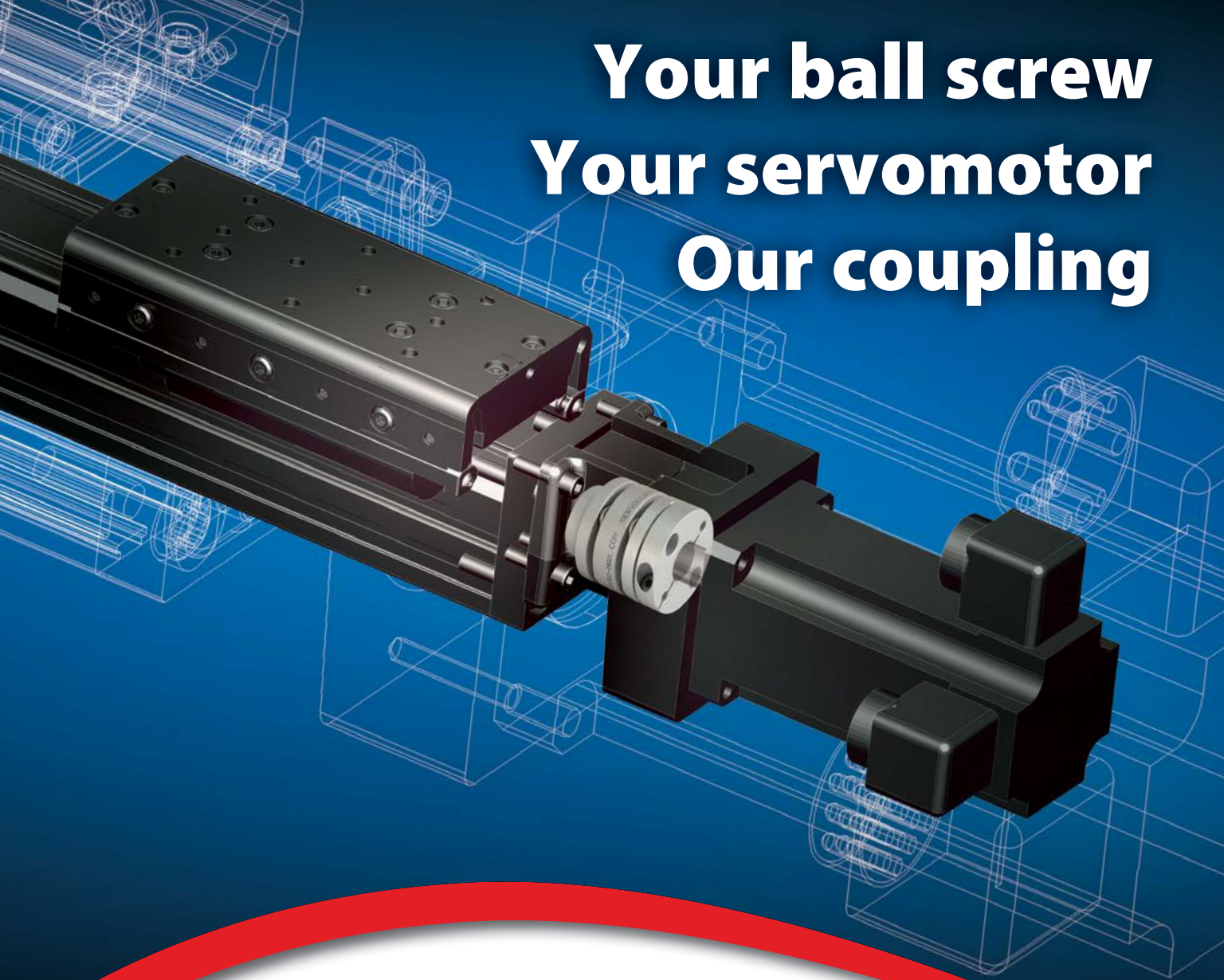

## ***Together a winning combination for today's servomotor applications.***

Our ServoClass® couplings have been recently redesigned to enable your actuator to go even faster and achieve the positional accuracy that will take your designs to the next level. Our couplings will do all this with low bearing loads.

3 New sizes now available.

Now, size, select and see the right ServoClass® coupling solution for your application with Zero-Max 3D CAD files.

Check our FAST deliveries.



# The BIG Picture

When you work day-in and day-out with components — like gears, bearings or electric motors, for example — it's easy to forget that those components are always part of a much bigger system. The best gears can fail if the system around them fails. Likewise for bearings, motors, couplings and so on.

To make matters more complicated, today's components are surrounded by, driven by and controlled by electronics. Sensors give feedback to controls, and components have to respond.

This issue's focus on mechatronics highlights this systems-oriented approach to engineering. Perhaps Jeff Hemphill, CTO of Schaeffler Group USA said it best: "We make everything from washers to complete mechatronic solutions. We come at it from a very unique perspective in that we really understand all the details and exactly how everything comes together at the system level."

In the article "Changing Technologies, Changing Perspectives," by Senior Editor Matthew Jaster (page 18), you can read more of Hemphill's insights about how Schaeffler Group's approach to mechatronics is helping them engineer systems that are more suitable for the automobiles and machinery of tomorrow.

Of course, mechatronics isn't really a new concept, as Senior Editor Jack McGuinn points out in his article, "Mechatronics - Gaining Control and Applications" (page 22). It's actually been around for some time, but only in recent years has it really taken on a life of its own, especially in fields like robotics, medical devices and even oil & gas.

But the big picture can go even beyond total systems design. Alex Cannella's article on product lifecycle management (page 26) delves

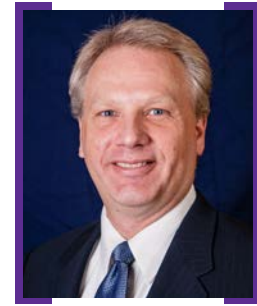

into the reasons why manufacturers should consider adopting a PLM strategy. Today's software is tapping into the Industrial Internet of Things, taking readings from sensors in the field, to give manufacturers the feedback they need to keep improving products, anticipate maintenance issues and mitigate risks. PLM's goal is to get the right information into the hands of the people who can use it. So it's a tool that extends far beyond the design engineering department and touches on marketing, sales, shipping and legal issues.

What does development look like at your company? Do your products take advantage of the Industrial Internet of Things? Are your mechanical engineers working closely with the electrical engineers? Do you develop individual components or complete systems? And perhaps most importantly, do you develop your products with the whole lifecycle in mind? I'd love to hear your thoughts, so please drop me a line at [wrs@powertransmission.com](mailto:wrs@powertransmission.com).

In the meantime, happy reading. I hope you enjoy the big picture.

Randy Stott





APRIL 3-6, 2017 | MCCORMICK PLACE | CHICAGO, ILLINOIS

North America's Broadest Automation Solutions Show

# AUTOMATE • 2017



Connect.  
Discover.  
Grow.



HERE'S  
WHY YOU  
SHOULD  
ATTEND

**Connect** with top suppliers and industry experts

**Discover** new technologies, and learn how automation can benefit your company

**Grow** your business using knowledge gained on the show floor, at Expert Huddles, and in the conference sessions

**REGISTER TODAY!**

Free registration available at:  
[AutomateShow.com/PTEngineering](http://AutomateShow.com/PTEngineering)

Brought to you by



Collocated with  PROMAT 2017

# R+W

## INTRODUCES STE SAFETY COUPLING SERIES

R+W has recently narrowed the gap between its classic precision and industrial drive safety couplings with the new STE series. Featuring the well proven technology of the ball-detent safety element system, which disconnects drivelines within milliseconds of a torque overload event, this version is more cost effective and available in smaller sizes than the standard ST product line of the past.

The STE series is available in three sizes and can be configured for disengagement torques between 200 Nm to 14,000 Nm. Customers can individually adjust the safety elements to fine tune the disengagement torque level, or change the number of safety elements to make large adjustments to the disengagement torque range even after installation. This particular model is available in the full disengagement function system, and comes with an optional ring for easier re-engagement.

Unlike the previous ST2 design of elastomer safety couplings, this version makes use of R+W EK elastomer couplings, with a more compact polyurethane insert, saving space and cost for applications without severe vibration.



The elastomer inserts, which can be replaced in the field, provide some vibration damping and compensation for misalignment. Shore hardness is selected by the customer based on the requirements of the application.

**For more information:**

R+W America  
 Phone: (630) 521-9911  
<http://www.rw-america.com/products/industrial-drive-couplings/safety-couplings/ste.html>



## Torque Systems

### RELEASES NEW FAMILY OF BRUSH DC MOTORS

Torque Systems, a division of SL-MTI, has developed a high performance family of three new size 15 permanent magnet DC motors. They are used in a wide range of applications that includes semiconductor processing equipment robots UAVs and medical devices. The longer stack size 15 DC motor (model MS1525-A) reaches a rated torque value of 10 ounce-inches at 6,700 rpm. Rated power output is an impressive 50 watts out. Shorter models MS1509-A and MS1515-A provide 30 and 40 watts out respectively. All models have a top speed of 10,000 rpm. The theoretical acceleration performance ranges from 45 K radians per second squared up to 65 K radians per second squared. Peak torque reached 77.8 ounce-inches on the MS1525-A model.

**For more information:**

Torque Systems  
 Phone: (800) 669-5112  
[www.slmti.com](http://www.slmti.com)

# MMI

## IMPROVES AND EXPANDS O-RING PRODUCTION

Michigan Manufacturing International (MMI) announced that it recently added new stainless steel and Inconel seal ring production to its impressive list of capabilities. With this new service, technicians can now provide precision welding, making MMI a one-stop shop for original equipment manufacturers (OEMs).

Stainless and Inconel O-rings from MMI can be used for applications such as pressure control valves where non-metallic seals are not suitable or will not be reliable due to factors such as temperature or pressure. These long-lasting rings fabricated by MMI are made so the seam is indistinguishable from the rest of the ring. In addition to the standard profiles, MMI can design seals to meet the customer's specifications. Stainless and Inconel rings are used in various applications in the oil and gas, chemicals, plastics, aerospace, and semi-conductor industries.

Jacob Prak, CEO of MMI, mentioned that the company is growing and evolving to meet its customers' needs. "Our goal is to design the most effective and highest quality solutions for our customers. Adding this new service helps ensure that we can provide the best solution for the intended use, customized according to the specific application. Ring making is one more way that we can partner with our customers to design, manufacture, and deliver solutions to challenging equipment situations."

**For more information:**  
Michigan Manufacturing International  
Phone: (800) 677-0504  
[www.michmfg.com](http://www.michmfg.com)



### Extraordinary People Make the Difference



*Amy Sovina  
Lead Gear Inspector*

**She'll put 27,000 hours  
into your gear inspection**

In an increasingly complex industry where quality is paramount, it's nice to know that Amy Sovina is in our Quality Assurance Lab. Yes, we've invested millions in one of the industry's most advanced and productive quality rooms, but you can't put a price on experience. Or reliability. Or results. With 27,000 hours of inspection experience, there's almost nothing that Amy, or our other FCG quality experts, haven't seen.

Gear quality challenges? Relax. Amy's got this.

***Excellence Without Exception***

**FOREST CITY GEAR**



815-623-2168 | [www.forestcitygear.com](http://www.forestcitygear.com)

# PRECISELY WHAT YOU NEED

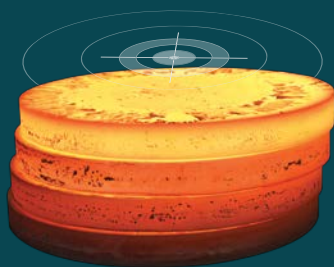

**CARBON • ALLOY • STAINLESS  
UP TO 54" OD & 10" THICK**

**You already know us for our high quality seamless rolled rings, but now we've expanded our product line to include forged discs manufactured with precise and accurate tolerances and shipped in as few as five days.**

**McINNES  
ROLLED RINGS**

**Speed. Quality.  
McInnes Rolled Rings.**

[McInnesRolledRings.com/ForgedDiscs](http://McInnesRolledRings.com/ForgedDiscs)

**1.800.569.1420**

## Mayr

DEVELOPS NEW DISENGAGING TORQUE LIMITER

With their EAS-reverse, Mayr Power Transmission has developed a new, disengaging torque limiter on which all functional processes can be automated through the drive. It is easy to handle, permits long run-out times and re-engages again through slow backwards rotation. A housing also makes the clutch resistant to dust or spray water — and thus ideal for use in heavy mechanical engineering.

In case of rough operating and ambient conditions such as dust, dirt, spray water, heat or cold, the drive lines, particularly in heavy mechanical engineering, are frequently encapsulated and therefore hard to access. But these machines in particular require reliable overload protection. Therefore, Mayr has now developed with the EAS-reverse a robust, disengaging torque limiter which can withstand both high loads and which automatically re-engages — which is ideal for drives without access possibilities for re-engagement.

On the EAS-reverse torque limiter, all functional processes can be automated via the drive alone. In case of overload, if the torque exceeds the value set on the clutch, a patented disengagement mechanism separates the input and output almost residual torque-free with high switch-off and repetitive accuracy. The kinetic energy from the rotating masses stored in the system can slow down freely. After responding, the clutch can withstand long drive run-out times. Through slow reverse rotation, the EAS-reverse torque limiter re-engages automatically without the use of pneumatics or hydraulics.

The new EAS-reverse torque limiter transmits the torque with exceptionally low wear (<0.05°) and features hardened functional parts. It is easy to handle and represents adaptable,

branch-optimized solutions with its numerous versions and additional characteristics. In this way, for example, the combination with an elastomer coupling permits easy separation of the drive line by loosening a few screws, without the motor or gearbox having to be displaced.

In addition, applications with load-holding outputs can also be combined with a brake disk on the output side. The EAS-reverse can also easily be integrated into a solid housing with standard IEC or NEMA dimensions. It is thus protected against dust and spray water



and resistant to adverse ambient conditions. The new torque limiter already covers the first three construction sizes with a torque range from 80–2,500 Nm, and this range is now to be extended with a fourth construction size up to 5,000 Nm and a bore diameter of up to 100 mm. The EAS-reverse provides permanent protection for machines and protects them reliably against overload damage, thus ensuring operational safety and maximum productivity.

**For more information:**

Mayr Corporation  
Phone: (201) 445-7210  
[www.mayrcorp.com](http://www.mayrcorp.com)

# Huco Dynatork

AIR MOTORS BRING EFFICIENCY TO  
HAZARDOUS APPLICATION AREAS

Huco Dynatork 3 air motors bring efficiency, performance and versatility to hazardous application areas. When you require a low cost, efficient and reliable motor for applications in a sensitive environment, the Dynatork 3 air motor from Huco presents an optimum solution.

Designed for efficient, spark-free operation, the Dynatork 3 air motor offers simplicity and high performance even under harsh duty cycles. Affordable, compact and easy to maintain — such benefits have seen Dynatork 3 air motors utilised in the wood, hydrocarbon, paper, paint, food processing and even stealth industries.

The immediate benefit of selecting an air motor is that it offers spark-free operation without resorting to an expensive shielded ATEX-rated electric motor. In hazardous environments it's important to reduce the risk of sparks wherever possible, so specifying a motor that operates entirely on compressed air is the recommended and most cost effective solution. As a result, the Dynatork 3 air motor is compliant for use in ATEX Zone 1 applications.

The air motor incorporates Huco's unique free-floating piston technology, which minimizes air leakage past the piston. This ensures that the vast majority of the energy present in the compressed air is converted into motion, resulting in air consumption up to 80 percent less than an equivalent vane air motor. This of course translates into substantial energy savings for end users, even during heavy operation.

Air is supplied at up to 100 psi to each of the three pistons through an integral rotary valve, providing maximum torque from start-up. The motor can also be fitted with torque sensors to provide closed loop feedback for accurate position control without the need for expensive electronic controls.

## For more information:

Huco Dynatork  
Phone: +44 (0) 1992 501900  
[www.huco.com](http://www.huco.com)



# BK

THE COUPLING. ABSOLUTE  
PRECISION 0.1-100,000 NM.



[WWW.RW-AMERICA.COM](http://WWW.RW-AMERICA.COM)

**R+W**  
A POPPE + POTTHOFF COMPANY

# IKO

## MINIATURE BEARING LINE OFFERS CUSTOM DESIGN OPTIONS

IKO's standard miniature bearings line is now available in rail widths from 1 mm to 25 mm with wide-bearing options as high as 42 mm. They are also available in up to four different lengths—compact, standard, long and extra-long in many sizes.

The variety of widths and bearing lengths enables designers to easily tailor a miniature bearing system to specific payload requirements. IKO's largest miniature linear bearings with the larger bearing lengths can handle much higher dynamic and moment loads than expected from a miniature unit. The largest miniature models for example, have dynamic load ratings in excess of 16,600 N (LWLG25) and moment load ratings over 320 N•m (MLFG42) in the roll axis.

To ensure its miniature bearings keep running smoothly, IKO has integrated its C-Lube long-term lubrication system into many units, which

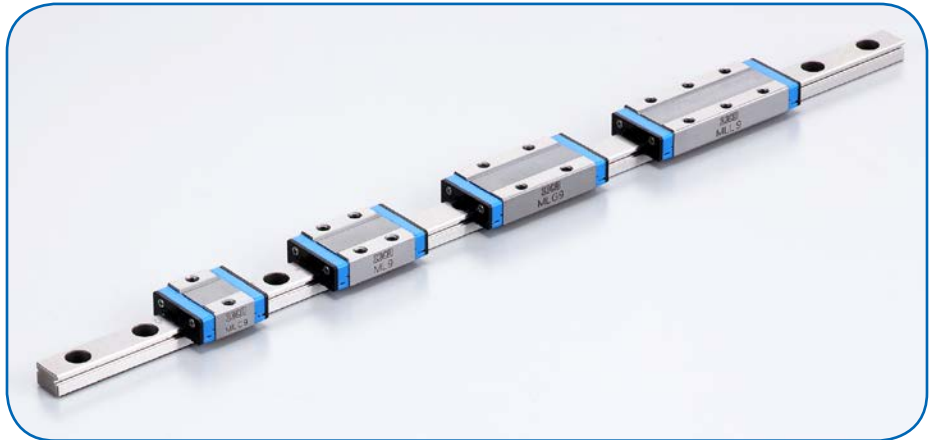

offers a controlled release of lubricant over 20,000 km of operation. C-Lube technology can be integrated into bearings as small as 3 mm wide.

**For more information:**

IKO  
Phone: (800) 922-0337  
[www.ikont.com](http://www.ikont.com)

# DieQua offers more gearboxes

## Are You Selecting The Right Technology?

Whether your application is for precise motion control or for general power transmission, there are several gear technologies that can do the job. But which one does it best?

Only DieQua offers the widest range of gearmotors, speed reducers and servo gearheads along with the experience and expertise to help you select the optimal solution to satisfy your needs.

**If you are using gearboxes, you should be talking to DieQua!**

**DIEQUA**  
Corporation  
[www.diequa.com](http://www.diequa.com) 630-980-1133

### Power Transmission Solutions

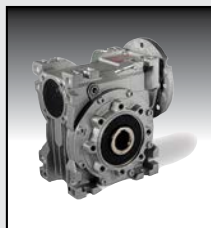

Worm Reducers

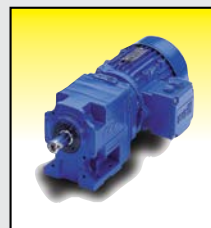

Helical Gearmotors



Spiral Bevel Gearboxes

### Motion Control Solutions



Planetary Gearheads

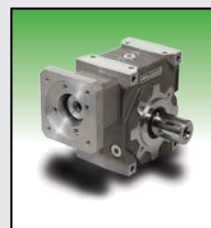

Servo Worm Gearheads



Precision Cycloidals

# Zero-Max

OFFERS CUSTOM CD COUPLING DESIGN FOR CHALLENGING MOTION SYSTEM APPLICATIONS

Connecting motion components over a long space requires multiple engineering design disciplines to manufacture a coupling that maintains smooth operation and avoids rotation through the system's axial natural frequency (ANF).

This Zero-Max Custom CD Coupling design is one of many different ones available for difficult and challenging motion system applications. The 80-inch floating shaft coupling pictured is designed around Zero-Max's CD Composite Disc technology bringing to bear several engineering disciplines. This coupling design was optimized such that the operational speed (2,600 rpm) is below the ANF point. That means that the coupling will never go through the critical speed and always operate in a sub-critical speed.

Key to this design is the accurate prediction of the axial natural frequency point based on Zero-Max's composite flex disc performance. Connecting

to these custom discs are 316 stainless steel hubs passivated for extra cleanliness required for the application. A three-inch diameter 80-inch long thin-walled alloy tube connects the two coupling assemblies at each end for mounting in the motion system.

The engineering disciplines Zero-Max applied to this and many other custom coupling applications include: metallurgy and alloy material design, composite disc formation, disc deflection control, precision fastening of components and dynamic coupling balancing. These engineering disciplines required precise control of tube stiffness, stiffness properties of the composite disc and overall weight of the coupling assembly.

(Note: Often a custom coupling can be designed so that the ANF point is above the particular application's maximum speed. When this is not possible



and the desired operational speed exceeds the ANF band, it is possible to design the coupling so that the ANF band will be within a speed range not critical for that application. The motion system operator simply programs his system to run through the ANF band to the desired operating rpm range. This ensures smooth and consistent performance where needed.)

## For more information:

Zero-Max, Inc.  
Phone: (800) 533-1731  
[www.zero-max.com](http://www.zero-max.com)

## WORLD LEADING INSPECTION & TESTING



## SUPER PRECISION CUSTOM BEARINGS



✓ SOURCE QUALIFICATION, FAILURE ANALYSIS  
REVERSE ENGINEERING INSPECTION

✓ ENDURANCE, ENVIRONMENTAL,  
IMPACT/STATIC LOAD TESTING



✓ CORROSION RESISTANT, HIGH TEMPERATURE,  
HIGH FATIGUE LIFE BEARINGS

✓ SHORT LEAD TIMES, SMALL PRODUCTION  
RUNS, COST-EFFICIENT SOLUTIONS

Napoleon Engineering Services - Visit us at [nesbearings.com](http://nesbearings.com) or call (877) 870-3200



Quality Solutions Since 1960



- Standard Components
- Made to Print Parts & Assemblies
- Design & Engineering

**Nordex.com**

sales@nordex.com  
eng@nordex.com

Phone: (800) 243-0986  
or Call: (203) 775-4877

## AutomationDirect

EXPANDS LINE OF UNMANAGED ETHERNET SWITCHES

AutomationDirect's line of Stride Unmanaged Industrial Ethernet Switches now offers even more connectivity choices for Ethernet applications. The new Stride SE2 series DIN rail mountable switches offer up to 16 ports and include models with Gigabit Ethernet and SFP options; select models are IP65 rated to withstand washdown environments. These Ethernet switches feature a "plug and play" design with no user setup required and immediately start operating once powered up and connected to the network.

Starting at \$75.00, SE2 series switches offer a wide operating temperature range and are available with a 12-48

VDC or 18-30 VAC redundant power input, reverse polarity protection, and IP30 metal cases.

Stride Ethernet switches, designed for the industrial environment, survive extreme temperatures, as well as noisy industrial power. Meeting hazardous location requirements (Class I Div. 2), and the IEC60068-2 standard for vibration resilience, the Stride switches provide years of reliable connectivity in applications too tough for commercial grade switches.

**For more information:**

AutomationDirect  
Phone: (800) 633-0405  
[www.automationdirect.com](http://www.automationdirect.com)



## Siemens

SIMPLIFIES MOTION CONTROL TASKS WITH TECHNOLOGY CONTROLLER

Siemens has matched its new advanced Simatic S7-1500 T-CPU controller with its popular Sinamics servo drive system, simplifying complex motion control tasks.

The matched controller and drive system are integrated into Siemens TIA Portal engineering framework, making them suitable for electronic gearing, camming and other advanced motion control applications. Additionally, the new controller is suitable for safety applications, eliminating the need for multiple CPUs for standard, safety and

motion control automation tasks.

An easy-to-use integrated Cam Editor simplifies configuration, optimization

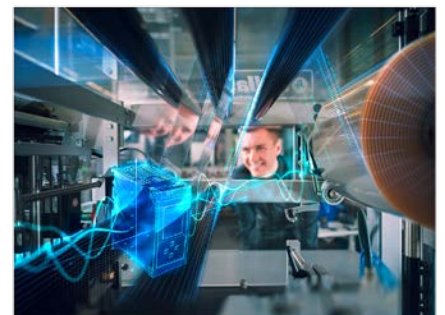



tion and diagnostics of variable, position-dependent transmission ratios between leading and following axes. The cams can be changed or readjusted for product changes, even while the machine is running.

Siemens Digital Factory (DF) offers a comprehensive portfolio of seamlessly integrated hardware, software and technology-based services in order to support manufacturing companies worldwide in enhancing the flexibility and efficiency of their manufacturing processes and reducing the time to market of their products.

**For more information:**

Siemens Industry Inc.  
<http://sie.ag/2i67fYZ>

## Heidenhain

INTRODUCES LINEAR AND ANGLE ENCODERS AT PHOTONICS WEST

Heidenhain displayed precision measurement components for the photonics industry at the Photonics West trade show in San Francisco, California from January 28–February 2. Heidenhain's linear and angle encoders were highlighted.

A feature on the linear side was the LIF 400 1Dplus scale from Heidenhain that is a uniquely innovative two-dimensional encoder. It is frictionless with gratings in two dimensions, and includes models featuring two or three scanning units for simultaneous measurement of both the X and Y directions. The scale allows measurement of linear guiding and thermal drift errors during movements of a stage or machine, allowing the processing and immediate compensation of guiding and thermal drift errors.

On the angle encoder side, Heidenhain's newest MRP 5000 angle encoder was on display. This is the result of a development of a new product family that is a merger of Heidenhain bearing and an-



gle encoder technologies. This unique module series contains bearing sets not conventionally available, and are able to be integrated with various encoder types to yield highly stiff modules that are easy to install. This new component family represents a successful merging of the key requirements for precision rotary axes used in metrology, calibration devices, automation technology, micro machining, and the semiconductor industry.

**For more information:**

Heidenhain Corporation  
Phone: (847) 490-1191  
[www.heidenhain.us](http://www.heidenhain.us)

## Regal Beloit

LAUNCHES NEW FEATURES FOR SEALMASTER BALL BEARING

Regal Beloit Corporation has announced it has launched the Time Saving Axial Groove in Bore feature to the SealMaster Large Bore Performance Gold Line Mounted Ball Bearing. The new feature is available in both a medium 2<sup>7</sup>/<sub>16</sub>" and up and standard 2<sup>1</sup>/<sub>16</sub>" and up shaft sizes, and the Time Saving axial groove in the inner ring bore allows for easier bearing re-

moval. This design provides clearance from the burr created by the setscrew used to lock the bearing to the shaft, which makes removal difficult and can cause damage to the shaft during removal. This feature has no impact to ball path roundness, load and speed rating, strength or bearing performance.

"Through years of customer discussions, on-site installation and removal observations, it was evident that the burr created by the setscrew had a significant impact on the time required to remove mounted bearings," said Ian Rubin, director of marketing, bearings, at Regal Beloit Corporation. "With time being a very valuable commodity in plant operation, we recognized the importance of developing a solution that reduces downtime and lost production, in turn potentially saving thousands of dollars."

In addition to the time and related costs saved during bearing removal, the design also reduces damage to the shaft. A reduction in damage to the shaft not only then reduces the cost associated with repairing the shaft before reuse, it can eliminate the cost of having to replace the shaft.

**For more information:**

Regal Beloit Corporation  
Phone: (859) 342-7900  
[www.regalpts.com](http://www.regalpts.com)



# HMB, Inc.

OFFERS T12HP DIGITAL TORQUE TRANSDUCER

HBM, Inc. has introduced the new T12HP digital torque transducer. The T12HP supports dynamic measurements in the test stand and provides precision, particularly in terms of temperature stability. Temperature influences have virtually no impact on the measurement result, due to a TC0 value of 0.005%/10K. In addition, the resulting FlexRange function provided by the T12HP allows users to take a closer look at any partial range of the full nominal (rated) measurement range.

The T12HP, therefore, meets the market requirements for increasingly flexible and efficient test cycles; for example, in the development of ever more energy-efficient motors. Due to the T12HP's integrated and unparalleled high basic accuracy and the resulting FlexRange function, users can run more detailed analyses in any partial range from the full measurement range—as if looking through a magnifying glass. Unlike other technologies used in the market (“Dual Range”), different measurement tasks can be performed using a single characteristic curve. Switching to a second measurement range is a thing of the past with T12HP. Moreover, test bench setup times are reduced, and besides, utilization as well as the number of tests can be increased.

CAN, Profibus, EtherCAT, and Profinet interfaces ensure easy integration of the T12HP torque transducer with different test stand concepts. The T12HP measurement flange is in-

stalled directly in the drivetrain and is, therefore, maintenance free. The transducer is available with different nominal (rated) torques, ranging from 100 Nm to 10 kNm.

The T12HP digital torque transducer is the successor of the “T12” model that was introduced 11 years ago and takes



over its role as HBM's flagship product range of torque sensors (“HBM smarttorque”). As the first company to provide a measuring flange and fully digital torque sensors, HBM has continuously strived to achieve higher levels of innovation in torque measurement for decades so that users benefit from meaningful data for further improvement in drives.

**For more information:**

HBM, Inc.  
Phone: (800) 578-4260  
[www.hbm.com](http://www.hbm.com)



## THIN ENOUGH?

- BXR Brakes
- Up to 480 in-lbs static
  - Up to a 1.125" bore
  - 19 watts or less
  - Produced for over 10 years

Our Innovative design features a very thin profile, reducing weight and saving space.

For more information:  
Call: 800.533.1731  
[www.mikipulley-us.com](http://www.mikipulley-us.com)



# Curtiss-Wright

INTRODUCES OFF-HIGHWAY INNOVATIONS AT IFPE 2017

Curtiss-Wright's Industrial division has announced its attendance at the International Fluid Power Exposition (IFPE 2017) in Las Vegas. The show, which is co-located within the CONEXPO-CON/AGG 2017 exhibition, is an ideal opportunity for Curtiss-Wright to showcase the latest innovations from its product brands of Arens Controls, Penny & Giles and Williams Controls.

Commenting for Curtiss-Wright, Senior Vice President and General Manager of the Industrial division, Kevin Rayment says: "This is one of the few industry trade shows in North America where most of our legacy product brands will be exhibited together. Products from the division's diverse portfolio are suitable for a wide range of applications within off-highway specialty vehicles, from wheeled loaders, skid-steer loaders, excavators, compactors, heavy haulers and articulated dump-trucks, to telehandlers, mobile cranes and aerial work platforms."

The product brands within Curtiss-Wright's Industrial division have extensive experience in designing and manufacturing solutions for the monitoring and control of vehicles operating in extreme conditions, including applications throughout the construction and off-highway sectors.

Arens Controls products will include by-wire shift selectors for automatic and automated manual transmissions; and off-highway mechatronic controls including mechanical lever shifters and hydrostatic lever controls. Key products include electric and hybrid vehicle power management systems such as traction inverters, voltage converters and inverters and power distribution modules.

The Penny & Giles branded products will include finger- and hand-operated, multi-axis joystick controllers, position sensors and examples of custom



HMI systems demonstrating the growing capability for integrated operator controls.

Finally, the Williams Controls brand will be represented by a range of floor-mounted electronic throttle controls, including suspended and rocker pedal versions; with complementary systems that include lever-operated and rotary electronic hand controls and new Hall-effect rotary position sensors.

#### For more information:

Curtiss-Wright Corporation  
Phone: +44 1425 271444  
[www.cw-industrialgroup.com](http://www.cw-industrialgroup.com)

OUR **EXCELLENCE**

## GEAR DESIGN SOFTWARE JUST GOT MORE POWERFUL: NOW WITH BEVEL GEAR MODULE!



*The tried-and-true, quick-and-easy way to optimize gear designs with minimal input is now right at your designers' fingertips:*

- Applicable to all common gear types – including bevel gears!
- Optimizes gear design, runs load/life analysis, and calculates manufacturing and inspection data.
- Easily mastered by even those who aren't gear experts.

Visit:

[www.excel-lentsoftware.com](http://www.excel-lentsoftware.com)

**EXCEL  
GEAR, INC.**  
DRIVEN BY EXCELLENCE

**Ready to Excel? Contact: 815.623.3414 / [www.excelgear.com](http://www.excelgear.com)**

# Changing Technologies, Changing Perspectives

## A Conversation with Jeff Hemphill, CTO at Schaeffler Group USA Inc.

Matthew Jaster, Senior Editor



We first heard from Jeff Hemphill, CTO at Schaeffler Group USA Inc., during the CTI Symposium USA that took place May 2016 in Novi, Michigan. Hemphill discussed how Schaeffler was creating an entirely new mobile ecosystem by improving transmission efficiency and noise, vibration and harshness (NVH) testing. Hemphill's presentation was one of the highlights of the week. Months later, *PTE Magazine* had an opportunity to further discuss the automotive industry, mechatronics and Schaeffler's unique role in creating these new mobile ecosystems.

### Complete Mechatronic Solutions

During CTI, Hemphill talked about looking at potential technologies in new ways by "rearranging" the components in automotive systems. He believes Schaeffler is in a unique position in the mechanical power transmission market to accomplish this.

"We make everything from washers to complete mechatronic solutions. We come at it from a very unique perspective in that we really understand all the details and exactly how everything comes together at the system level. This allows us to put things together in different ways," Hemphill said.

One example is the company's E-Clutch for manual transmissions in Europe. Hemphill said that one of the greatest challenges in automobile applications is to hybridize a manual transmission because the computer never knows exactly what the human driver is going to do. With the E-Clutch, the company created a product where a human is driving and operating the clutch, but the computer can also operate it.

Depending on the development stage, the new E-Clutch system either operates the clutch only under specific driving situations, or completely automates all clutch operations. This enables fuel saving driving strategies, from "sailing" to electrically supported driving, to be integrated into vehicles with manual transmissions.

In the automotive market, Hemphill says that everything for a supplier comes down to saving fuel or saving money.

"This is where things are really changing in terms of shared ownership. Vehicles are used more like in fleets than sitting in people's garages. The hours of usage go up which really changes the TCO (total cost of ownership) for the fleet owner," he said.

This opens the door for new solutions, like the adoption of battery-electric vehicles. "When you have a steady,

relatively cheap electricity supply and you eliminate the maintenance issues that come with combustion engines and transmissions, it pays for itself faster than a commuter. In that picture, mechatronics are very important," Hemphill added.

He also believes autonomy is going to play a large role in our shared mobility future. "For an autonomous vehicle to work, it's going to need control of everything in the vehicle. That means you need many more actuators, everything that is moving will become mechatronic in some way," Hemphill said.

### The Importance of E-Mobility

In 2011, the company had a lot of activity in both the automotive and industrial sectors that focused on renewable energy or electric or hybrid vehicles.

"We wanted to bring that detailed knowledge together so we could add



Schaeffler's 48-volt hybrid module provides a point of entry into hybridization and offers potential for reducing CO<sub>2</sub> emissions.



The active roll control system compensates movements in an automobile chassis caused by driving around corners or on uneven road surfaces.

some resources, restructure some others and try to generate some new solutions,” Hemphill said. “We formed our E-Mobility Systems Division as a result.”

Schaeffler engineers took out the conventional powertrain from a vehicle and put in flexible hybrid and electrical architecture. They were able to study in one vehicle, electric wheel motors, electric axles, and also a range extender with a combustion engine in the same car.

“It was basically a rolling laboratory. It was a way to study the advantages and disadvantages of different types of technology. It’s the systematic approach that we’re taking with E-Mobility,” Hemphill said.

Many of the technologies first used in this rolling laboratory are now Schaeffler products. The wheel motors, for example, are now on their third generation.

“We’re convinced there is real potential for wheel motors when we start seeing more RoboCab (autonomous taxi services) that companies like Google and others are working on,” Hemphill said. “When a vehicle’s job is to operate at low-speeds in congested cities, it’s helpful to have a small vehicle and put the powertrain into the wheels. This will free up space for passengers or storage.”

### Electric and Hybrid Challenges

Hemphill believes the potential and flexibility of hybrid and electric vehicles from an engineering standpoint is pretty easy to take advantage of. “The issue is largely battery cost,” Hemphill said. “Schaeffler has come up with a couple of things to combat these costs.”

One idea is Schaeffler’s hybrid module. It’s an electric motor with a disconnect clutch and a damper, all built into an aluminum housing that you can bolt in-between a conventional engine and transmission.

“This makes the vehicle a hybrid, to-

gether with power and batteries. You don’t have to develop a purpose-built engine for your hybrid vehicle which can save you hundreds of millions of dollars. We have two in production right now and the next generation is entering production over the next sev-

eral years,” Hemphill said.

Schaeffler is also working on how to make better use of the car battery. The company has a number of solutions including a 48-volt mild hybrid for automatic transmission (similar to the manual). Here, a 48-volt motor gener-

**Martin**

Quality PT Products  
In Stock When & Where  
You Need Them

*Martin* products are stocked in more than 30 North American branches and MTO's ship same day or next day from a location near you.

Free PT Maintenance & Troubleshooting Guide  
Scan or visit <http://bit.ly/2aQL322> to download!

[www.martinsprocket.com](http://www.martinsprocket.com)  
817-258-3000

ator is connected inside the transmission giving a lot more flexibility than the usual solution which is typically putting it on the belt drive where it has to turn with the engine.

“We connected this to the transmission and that means it’s also directly connected to the road,” Hemphill said. “When you’re coasting or slowing the vehicle down you can collect all of that kinetic energy directly into the batteries which you can’t do with a belt starter alternator because you have to use some of it to crank over the engine. It’s better in that respect and it also can do more with a smaller battery.”

Additionally, they connected all the accessories to that motor generator. So items such as the air conditioning, transmission oil pump, vacuum pump and water pump can also be driven from the road when the vehicle is slowing down. That means that you’re recovering energy mechanically as well as electrically. “It’s reconfiguring the system to make the most use of the energy available in the vehicle with the least amount of cost,” Hemphill said.



Depending on the development stage, the new E-Clutch system either operates the clutch only under specific driving situations, or completely automates all clutch operations.

### Learning from the Past, Preparing for the Future

Another interesting development from Schaeffler is the company’s electro-mechanical anti-roll stabilizer. “This is basically an anti-sway bar that we cut

apart in the middle and put in a brushless DC motor with a three-stage planetary gear set allowing us to not just passively control the vehicles roll but also actively,” Hemphill said.

The active roll control system compensates movements in an automo-

**E-BIKE**  
On dedicated cycle routes, it is possible to cover short distances really quickly and without damaging the environment using high-performance pedelecs. On-board system: Schaeffler hardware and software.

**BIO-HYBRID**  
This innovative and compact mobility solution for urban areas offers more than just protection from the weather: Four wheels and the electric pedelec drive system provide both extremely stable driving and plenty of storage space.

**ELECTRIC AUTOMOBILE**  
Schaeffler's electric axle is making inner city traffic noise a thing of the past.

**E-BOARD**  
Highly maneuverable, fitted with a hydraulic braking system and with a range of 25 km, this is the ideal means of transport for short distances in urban areas.

**SELF-DRIVING TAXI**  
Autonomously driven buses with Schaeffler's integral wheel hub drive provide on-demand, emissions-free local public transport. With the exception of the battery, all the drive components are incorporated into the wheel.

**HYBRID VEHICLE**  
Schaeffler's hybrid components are helping improve the efficiency of future conventional powertrains which include an internal combustion engine.

**SCHAEFFLER**

A few examples of Schaeffler's "Mobility for Tomorrow" strategy.

bile chassis caused by driving around corners or on uneven road surfaces. When combined with intelligent wheel bearings, a high-accuracy satellite navigation system and a communications module, it may, in the future, be possible to produce a real-time image of the condition of the road. This could then be used to send information to vehicles following behind or to the infrastructure operator.

If a vehicle is going around the corner and wants to lean to the outside, this enables the vehicle to push back and straighten out. "That's a good performance advantage, in the autonomous space, and it reinforces what we learned many years ago. The more disengaged the driver is to the operation of the vehicle, the more every small disturbance disturbs them," Hemphill said.

First, some history on these changing technologies: This goes back 15 to 20 years ago when Schaeffler introduced some automatically shifted manual transmissions in Europe. It was a great solution from a cost perspective, easy to implement, use an existing transmission and it made the manual transmission behave like an automatic. "We developed the system to the point that the computer could shift far more quickly and smoothly than a human," Hemphill said.

"But the problem was the driver no longer knew when the vehicle was going to shift. In a manual, you have to interrupt the engine torque in order to select a new gear, so the computer would open the clutch, the vehicle would stop accelerating for a fraction of a second and the driver and passengers weren't expecting it. They didn't like it at all. We've used the tech in other applications, like dual clutch transmission but no longer in automated manual transmissions."

Fast forward to autonomous vehicles, you can imagine that's 10-times worse. "Now, the driver is not even holding the steering wheel anymore. So every little pothole, speed bump, certainly no shifting would be tolerated so things like roll control (which can be used to hold the wheel up, for example, are going to become more and more important now that the driv-

er and passengers are so disengaged," Hemphill said.

These technologies reinforce Schaeffler's "Mobility for Tomorrow" strategy and the company's desire to expand its R&D efforts with an emphasis on digitization.

"The future is going to be complicated in our business," Hemphill said. "I believe the automotive industry will be a mixture of shared and personal ownership of vehicles and personally-driven versus autonomous. All of these so-

lutions are going to exist on our roads side-by-side." **PTE**

**For more information:**  
Schaeffler Group USA, Inc.  
Phone: (803) 548-8500  
[www.schaeffler.us](http://www.schaeffler.us)

For Related Articles Search

mechatronics

at [www.powertransmission.com](http://www.powertransmission.com)



**Your Objective:**

One face in perfect alignment with another. *For infinity.*

**No problems. No distress. No delays.**

That's the same objective you have for choosing your gear producer. Circle Gear's objective is to engage with every customer's objectives.

- ▶ **One to 1000 gears**
- ▶ **Customer designed or reverse engineered**
- ▶ **Gearbox repair, rebuild or redesign**
- ▶ **OEM or end-users**
- ▶ **ISO 9001:2015 Certified**



1501 S. 55th Court, Cicero, IL 60804  
(800) 637-9335  
(708) 652-1000 / Fax: (708) 652-1100  
[sales@circlegear.com](mailto:sales@circlegear.com)  
[www.circlegear.com](http://www.circlegear.com)



Spiral and Straight Bevel Gears (*Cut, Ground or Lapped*) • Spur Gears • Helical Gears • Long Shafts • Herringbone Gears • Involute and Straight Sided Splines • Internal Gears • Worm and Worm Gears • Racks • Sprockets • ISO Certified

**Partnering with QualityReducer to provide Gearbox repair, rebuilding and reverse-engineering.**

# MECHATRONICS: Gaining Control and Applications

## “New” Technology Turning Heads — and Profits.

Jack McGuinn, Senior Editor

### Not to bury the lead, but did you know that mechatronics has been around since the 1960s?

For some, that is old news. For the majority others—who knew?

Mechatronics sounds like one of those slacker words, e.g. —“agreeance” or “sexting.” In reality mechatronics is an engineering-intensive interdisciplinary field that is a critical part of the yet-evolving, revolutionary advances in U.S. manufacturing technology. For today’s engineers with the sharpest pencils—especially in the United States—“manufacturing technology” is a bit of an oxymoron. After all, why has it taken *decades* for U.S. manufacturing to embrace mechatronics—something Europe and parts of Asia did years ago? The answer—if one exists to that question—can wait for another time. But one wonders; if there is an explanation, is it perhaps for the same reason that post-WWII U.S. automakers ignored the then-revolutionary, American-devised-provided quality processes that Japan’s automakers eagerly adopted to help rebuild devastated country, restore its economy, and revolutionize the automobile industry?

Putting all that aside, mechatronics has arrived and is garnering widespread acceptance here in the U.S. Just one of a number of mechatronics drivers is robotics. According to a recent report from the Robotics Industry Association (RIA), North American orders and shipments of robotics again broke all-time records in 2016; shipments increased 10 percent by volume over 2015, totaling sales of \$1.8B.

But *how* is mechatronics defined? *Many* ways, as it turns out, including:

- The science of intelligent machines

Or,

- A multidisciplinary field of science that includes a combination of mechanical engineering, electronics, computer engineering, telecommunications engineering, systems engineering and control engineering

And,

- The incorporation of electronics into mechanisms
- The integration of mechanical engineering with electronics and intelligent computer control
- The use of a synergistic integration of mechanics, electronics, and computer technology to produce enhanced products or systems
- The application of complex decision making to the operation of physical systems
- The addition of intelligence to a mechanical design or replacing mechanical designs with an intelligent electronic solution
- The synergistic combination of mechanical engineering,

electronic engineering, and software engineering

And my favorite, from Kevin Hull, application and deployment supervisor / motion control, Yaskawa America Incorporated: “Mechatronics is a way of doing things.”

Yaskawa has been “doing things” the mechatronics way since 1969, when Tetsuro Mori, an engineer for Yaskawa Electric Corporation, coined the word.

Existing applications for mechatronics include:

- Machine vision
- Automation and robotics
- Servo-mechanics
- Sensing and control systems
- Automotive engineering, automotive equipment in the design of subsystems such as anti-lock braking systems
- Computer-machine controls, such as computer driven machines like IE CNC milling machines
- Expert systems
- Industrial goods
- Consumer products
- Mechatronics systems
- Medical mechatronics, medical imaging systems
- Structural dynamic systems
- Transportation and vehicular systems
- Mechatronics as the new language of the automobile
- Computer aided and integrated manufacturing systems
- Computer-aided design
- Engineering and manufacturing systems
- Packaging
- Microcontrollers / PLCs
- Mobile apps
- M&E Engineering

But just what, exactly, do mechatronics engineers do?

Many things. According to one online source: “They unite the principles of mechanics, electronics, and computing to generate a simpler, more economical and reliable system. But over the years mechatronics has come to mean a methodology for designing products that exhibit fast, precise performance. These characteristics can be achieved by considering not only the mechanical design, but also the use of servo controls, sensors, and electronics.”

There are many engineers who posit that mechatronics is the spawn of robotics. Earlier-generation robotic arms, then unable to coordinate their movements without sensory feedback, have significantly improved thanks to advances in kinematics, dynamics, controls, sensor technology, and high-level programming—i.e., *mechatronics*. A short history:

- During the 1970s, mechatronics was concerned with



servo technology used in products such as automatic door openers, vending machines, and autofocus cameras.

- In the 1980s, as information technology was introduced, engineers began to embed microprocessors in mechanical systems to improve their performance.
- The 1990s saw the full arrival of the mechatronic age because of the increased use of computational intelligence in mechatronic products and systems.

Mechatronics is indeed an interdisciplinary field. An effective mechatronics engineer will have a background in mechanical engineering; materials science; electrical engineering; computer engineering (software & hardware engineering); computer science; systems and control engineering; and optical engineering.

With that knowledge mechatronics engineers are tasked with uniting the principles of mechanics, electronics, and computing to generate a simpler, more economical and reliable system. And that system today typically includes modern production equipment consisting of mechatronic modules that are integrated according to a “control architecture;” the most used architectures involve hierarchy, polyarchy, heterarchy (nobody said this was easy), and hybrid. The methods for achieving a technical effect are described by control algorithms, which might or might not utilize formal methods in their design.

So why now mechatronics? Was there a tipping point regarding the field’s now pervasive influence in manufacturing?

“A stronger and more refined integration between hardware and software has certainly been a governing factor,” says Yaskawa’s Hull. “Solutions have become easier to apply and maintain in production environments. Applications that may have demanded too much computing power in the past to be feasible are now more common and require significantly less support from a short list of experts.”

And since his company invented this process, it only makes sense to ask how Yaskawa defines it, in addition to “way of doing things.” “It is,” says Hull, “a philosophy made possible by the number of refined technologies that can be easily incorporated with one another like never before. For example, if a conveyor line goes down, there may be a faulty variable frequency drive (VFD) which provides power to the conveyors motor. A mechatronics philosophy means the VFD probably has a web server available. A local technician may be able to ask for remote assistance in troubleshooting the problem, allowing an engineer to remotely connect to

the drive and view the faults codes. Once a new drive is installed, a smart phone app might be used to upload parameters from the old drive and copy them into the replacement unit. The time to troubleshoot the problem and implement a solution can be greatly reduced.”

We put the same question to Cindy Daneker, Sr. Applications Engineer for SKF Linear & Actuation Technology (which, as a Swedish company, has been implementing mechatronics systems for around 50 years).

“Many customers have been using hydraulic and pneumatics for many years, but due to the maintenance required, and environmental concerns, they are switching to electro-mechanical solutions now. In the long run the electro-mechanical solutions are more cost effective. Accuracy and repeatability are also improved with the use of mechatronics, and industry today, with its advancements, requires this.”



Yaskawa 3-axis gantry system utilizing G-Code programming within MotionWorks IEC software to perform coordinated motion control (Photos courtesy Yaskawa).

After poring through a litany of definitions for mechatronics engineer, one might wonder if it is just a dressed-up name for what used to be known as “system integrators?”

“Sure,” says Hull. “Mechatronics is the integration of several disciplines. A system integrator has always played the role of pairing mechanical devices to their electronic controls, interfacing various pieces of equipment together, and determining attainable cycle rates when all the components are considered as a unit.”

And at SKF, says Daneker, “We often sell to system integrators, OEMs and end users (through distribution). The mechatronics engineers in our group range from application engineers helping size and select products, to actual design engineers at the factory levels.”

Returning to robotics and its influence on the growth of mechatronics, Daneker believes “Robotics is just one appli-

ation driving mechatronics, but also medical, oil & gas and ergonomics to name a few.”

Hull concurs, adding, “While I don’t think robotics has been a key driver, a robot exemplifies one of the greatest mechatronics solutions created. Physics, mechanics, electronics, software, pneumatics, vision, and even tactile feedback all come together as a single unit to provide increasingly unique and innovative automation.”

It would seem that companies marketing mechatronics systems would be required to have all the elements—from mechanical to electrical to software and more—under one technological, extremely vertical engineering umbrella.

Supporting that notion regarding engineering disciplines is Bill Leang, manager, motion engineering, Yaskawa America, Inc.

“In order to provide a complete mechatronics system, a company needs to have electrical/electronics engineers, software engineers, and mechanical engineers. These engineers work together in the design, fabrication, and test of the system. Taking a system approach is very important.” Leang explains that the “system components can be sourced from outside vendors.”

How much can all this cost, you may ask? Unfortunately, we can’t tell you.

“There’s no way to put a price on mechatronics,” says Hull. (In my world, that usually means get ready to dig deep.) “It’s a design philosophy more than anything. It could be argued that a great mechatronics design will save money in the long run.”

Daneker explains that at SKF, “Oftentimes, we sell components that may cost anywhere from a few dollars (linear ball bearings) to over \$100K (roller screws). There are times we also offer sub-assemblies which will also vary by price. In general, for a product such as a roller screw, the initial cost will be higher than a hydraulic cylinder, but the overall cost of ownership will be less expensive in the long run.

Given that mechatronics engineers apparently need to be virtual polymaths, what educational background do mechatronics engineers generally possess? “

Hull says that “Mechatronics engineers typically have a degree in mechanical, electrical, or computer engineering, but it takes more than just a degree to be a great mechatronics engineer. Engineers who like working with their hands, like to build things, and belong to school-sponsored clubs such as first robotics or building electric vehicles are great candidates. On-the-job training can’t be ignored either; having an open mind and a desire to learn more about the interdependencies between the mechatronics disciplines really goes a long way.”

Daneker adds that “Most (SKF) mechatronics engineers have degrees in mechanical or electrical engineering. Of course, there is a learning curve to learn about the individual products and applications where they can be used.”

Given the ongoing shortage of skilled workers—at all levels—how difficult has it been to recruit and keep mechatronics engineers? At SKF, says Daneker, somewhat surprisingly, “Since mechatronics touches a wide array of industries, keeping mechatronics engineers is not an issue, especially since this industry is growing.”

While at Yaskawa, even with its mechatronics DNA, Hull says “It’s an ongoing challenge to find the right people with the passion required to be a great mechatronics engineer. Engineering can be complicated, challenging and frustrating at times, but the reward of seeing months or years of hard work come together is worth it. There’s a real sense of accomplishment in solving engineering problems that improve on prior design using the latest innovations in mechatronics.”

OK. Here’s a scenario: one of a manufacturer’s conveyor lines suddenly goes down—how does mechatronics save the day?

“(Mechatronics) is a philosophy made possible by the number of refined technologies that can be easily incorporated with one another like never before,” Hull explains. “For example, if a conveyor line goes down, there may be a faulty variable frequency drive (VFD) which provides power to the conveyors motor. A mechatronics philosophy means the VFD probably has a web server available. A local technician may be able to ask for remote assistance in troubleshooting the problem, allowing an engineer to remotely connect to the drive and view the faults codes. Once a new drive is installed, a smart phone app might be used to upload parameters from the old drive and copy them into the replacement unit. The time to troubleshoot the problem and implement a solution can be greatly reduced.”

The above provides a smooth segue for asking, how does mechatronics improve overall quality?

“Reliability, accuracy and repeatability are key with me-

Yaskawa direct drive servo motor — 2 in. high and 5.3 in. in diameter — delivers 4 Nm of torque in the small footprint necessary for this micro machining application.

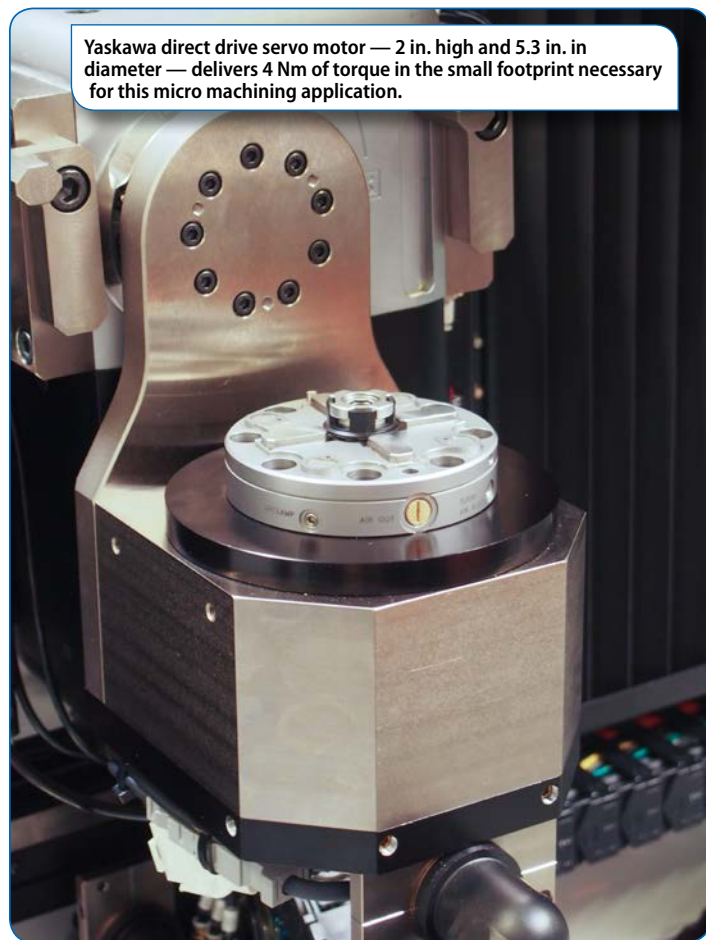

chatronics over products such as hydraulics and pneumatics,” says Daneker.

It is Hull’s belief that “Mechatronics improves quality because machines designed as a homogeneous unit are better at things like holding tolerances, identifying material defects and eliminating them before insertion into the final product, and taking measurements or visually confirming each and every part made.

Preventive maintenance is another area in which mechatronics creates a good deal of conversation — and for good reason.

“(Preventive maintenance) plays a huge role,” Hull asserts. “Again, because of tighter integration of high-precision sensors with fast CPUs and data acquisition techniques, performance characteristics of equipment can be easily benchmarked. Machines can re-check the performance of their mechanical components at regular intervals and compare the latest performance data to the factory benchmark conditions. If performance metrics indicate significant differences, users can be alerted to schedule investigative maintenance rather than waiting for a complete breakdown to occur.

And how, if at all, do the above translate to mechatronics-driven energy savings and effectiveness?

Hull frankly states that “Mechatronics (does not inherently) improve energy usage.” The good news, he goes on to say, is that “Companies and designers with a mechatronic philosophy (“a way of doing things” — remember?) will likely employ design elements which provide energy-efficient solutions. Providing energy efficiency might previously have been thought of as an extra effort; but a tightly integrated system using various sensors, electronics and data can be more easily optimized by slowing conveyors during lighter production runs, or push energy back to the power company instead of wasting it through mechanical brakes or regenerative resistors.”

What is next for mechatronics? After 50-odd years — glass half-full or half-empty?

“The glass is half-full,” says Daneker. “Due to the accuracy, reliability, repeatability and cost of ownership for mechatronics compared to other solutions, this industry is continuing to grow.”

And Hull?

“I’m optimistic about the future of mechatronics. Automation will continue to provide a greater degree of flexibility in ways we can only begin to imagine. Companion ideologies such as “Internet of Things” (IoT) are coming into play. The inclusion of real-time business information into automation processes will lead to new products and uniquely customized product choices that would have never been possible before.” **PTE**

(Primary sources for this article: [typesofengineeringdegrees.org](http://typesofengineeringdegrees.org); [enr.ncsu.edu](http://enr.ncsu.edu) (U. South Carolina); [journals.elsevier.com](http://journals.elsevier.com); [ocw.mit.edu](http://ocw.mit.edu) (MIT U.); [engineersaustralia.org](http://engineersaustralia.org); [wikipedia.org](http://wikipedia.org); [sciencedirect.com](http://sciencedirect.com); [gla.ac.uk](http://gla.ac.uk) (U. Glasgow); [technosoftinv.com](http://technosoftinv.com); [tryengineering.org](http://tryengineering.org).)

## WE’VE BEEN TEACHING THIS STUFF FOR YEARS

*Following is a brief first-person explanation of mechatronics from the academia side, provided by David L. Trumper, Professor of Mechanical Engineering at Massachusetts Institute of Technology (MIT). His class has an enrollment limit of 24 students due to lab size, and routinely fills this limit. Graduate students are the primary customers, who view it as highly valuable for supporting their research in many fields, since they learn a great deal about instrumentation and control.*

I started teaching at MIT in 1993. But before that, Prof. Will Durfee taught a course at MIT called Smart Machines, which was also a mechatronics course. He had been teaching that for maybe five years before I started. As well, Prof. Kevin Craig, who was at RPI (Rensselaer Polytechnic Institute) back then, had been teaching mechatronics for some time; it would be worthwhile to follow up on Prof. Craig’s work in this area.

If one looks realistically, there were lots of courses at universities that taught aspects of mechatronics for a long time, although they might not have been called that. For instance, Prof. Tomizuka at Berkeley was associated with hard disk technology from a controls perspective. Prof. T.C. Tsao, then at University of Illinois, Champaign-Urbana (now at UCLA) also taught that kind of material.

Overseas, the Dutch universities had lots of mechatronics education, primarily due to the influence of Philips company, which pioneered optical drives, such as CD players. Dr. Jan van Eijk at Philips, and later University of Delft, was a real pioneer in this area. And the Japanese universities and industry were working in this area as well.

In summary, I don’t think mechatronics is in any way a new field, as it has roots in many areas of electromechanics, controls, electronics, software, etc. These days, the pervasive availability of low-cost computation is driving mechatronic solutions into many more devices. Also, students are easily able to access the tools needed to implement mechatronic solutions.

### For more information:

David L. Trumper  
Professor of Mechanical Engineering  
Massachusetts Institute of Technology  
Rm. 10-140G  
77 Mass. Ave.  
Cambridge, MA 02139  
[trumper@mit.edu](mailto:trumper@mit.edu)



For Related Articles Search

mechatronics

at [www.powertransmission.com](http://www.powertransmission.com)

# Navigating Product Lifecycle Management

**Implementing product lifecycle management strategies can be intimidating at first glance, but it's also necessary. Here's why and how you should implement a PLM strategy of your own.**

Alex Cannella, News Editor

If you're on the outside looking in, product lifecycle management (PLM), or the process of organizing and directing a product's production from its inception to its disposal, can be a daunting topic. PLM strategies could be as simple as database management software or utilize cutting edge technology from the Industrial Internet of Things (IIoT), but it's all designed to accomplish one task: to give a company an established, coherent plan for designing and manufacturing their products and ensure all elements in a company, from marketing to production to service, are working in tandem to execute that plan.

That can be intimidating. Adopting PLM products alters how you operate as a company. It requires forethought to implement and changes in habit and policy to maintain. And at first glance, it may not seem important for a parts manufacturer, either. It makes sense to organize and coordinate efforts to build a car, which is made up of hundreds of complex parts, but someone might question whether the same is necessary for simpler products.

However, PLM is important for manufacturers of all stripes, and it offers the same advantages for parts manufacturers as it does for those who make finished products: better organization, consistently higher quality and faster turnaround.

"Manufacturers should consider utilizing PLM," Bill Lewis, global marketing director for Teamcenter, Siemens' main suite of PLM solutions, said. "They are generating enormous amounts of information about their product and processes. Digitalization of this intellectual property and the processes that generate and capitalize on it help to increase speed to market, improve risk mitigation and enable informed product decisions. If they are trying to manage things with excel, and email, and on shared drives, it doesn't take long for that to become overwhelming. PLM helps reduce the complexity and ensures the right information is communicated to the right people."

Kevin Wrenn, divisional general manager of PLM and ALM segments at PTC, agrees. "Even if you're not the ultimate company that delivers to the customer, PLM is impor-

tant for seamless collaboration," he said.

Both Siemens and PTC offer comprehensive software packages that allow you to organize your company's data and processes. Both are also starting to come out with IIoT-inspired products. PTC has developed a number of ambitious utility products, while Siemens is developing their MindSphere IIoT operating system.



Adopting PLM products can put a wealth of easily accessible information at your fingertips.

According to Wrenn, the future of product lifecycle management is in data analytics. Specifically, analytics based on data gathered in the field. Up until now, the "lifecycle" part of product lifecycle management ended once the product was shipped out the door, but IIoT technology is giving manufacturers the ability to truly monitor and improve their products for their entire lifetime, and that's changing the game.

"What's happening to [a lot of our customers] now is they're being forced into the field of digital engineering because their products can now be connected throughout their entire lifecycle," Wrenn said. "Where we used to talk about product lifecycle management, just like our competition did, where it starts from ideation and, for all intents and purposes, ends when it ships off the factory floor, now we're saying 'well, you can truly do product lifecycle management throughout the entire life of the product because you can stay connected to it.'"

Wrenn attributes this extension of a product's "lifecycle" largely to one of the many advances that fall under the IIoT umbrella: the advent of sensors that can monitor and transmit product information back from the field. While these sensors are often used to monitor the state of machine and

**“There is a lot of opportunity out there to leverage PLM both upstream and downstream in [a company’s] processes.”**

– Bill Lewis, global marketing director for Teamcenter, Siemens

provide early detection of any problems with its inner workings, Wrenn sees an opportunity to take that data, gather it, and implement the resulting findings in future products’ design iterations.

Sensors are giving manufacturers everywhere unprecedented insight into, and by extension, control over, their products. Just being able to monitor a product in the field while it’s being used offers a host of new information that can be turned around and used to improve the product. Manufacturers can discover unexpected weak points that they can shore up in future design iterations, analyze trends in how their customers utilize a particular product and build additional features to support those trends or, in some cases, even discover unexpected uses for their products in the field that open new marketing or design opportunities.

Much like any other company will have to, PTC has adjusted their strategy to incorporate some of the new, increasingly prevalent tech coming out of the Industrial Internet. The business has merged its ALM, PLM and CAD efforts together in a new drive that it’s dubbed “The Digital Engineering Journey.”

“It’s a way to guide clients into the era of digitization now that they can design smart, connected products and systems,” Wrenn said.

PTC’s Digital Engineering Journey is a model of the direction the PLM industry might move in. Faced with the glut of new information IIoT technology provides, PTC isn’t just developing new ways to help other manufacturers implement new PLM techniques, they’re using it for tracking their own products, as well, and creating a roadmap for other companies to follow in the process.

“[Say] we designed some features into our products,” Wrenn said. “Is anyone using them at all? Are they using them in a tighter range than we designed for, so we have a value engineering opportunity? Or are they using it out of range, therefore we have kind of a quality problem? So it’s the idea of en masse, can we analyze product performance data to figure out value engineering opportunities or sniff out quality issues we have in the field.”

Now, obviously, software lends itself a bit more readily to a PLM strategy than a motor might. These days, all you need to do to get a new, better version of your software out there is to upload it and let everyone download it overnight. But don’t let that dis-

suaude you; you can still incrementally improve and reiterate upon old designs as you get new information. While old customers may not line up to get your tweaked bearing or your updated motor, those extra iterations improve overall product quality and bring additional value and functionality to entice new customers with.

Outside of their more data-driven IIoT products, PTC is also offering other Industrial Internet-inspired solutions that take a normal design review into an environment where people can be immersed in that design whether or not they are in the same room. For example, they’re working on a product that utilizes augmented reality (AR) technology (stuff like Google Glass) to give workers out of the office more information during conference calls. The idea is that when one member of the team can’t be there in person or two teams in separate facilities need to put their heads together, they can still use PTC’s AR product to see digital avatars of others in the conference room and even inspect and interact with virtual blueprints of a physical product, which allows them to highlight and focus on individual systems or parts of the model. It’s not entirely unlike a one-way version of Star Wars’ holograms. Just don’t expect to pop up in the room as a blue mote of light.

Of course, somebody has to make those blueprints before they can be interacted with, and that’s what PTC’s Digital Twin feature is for. The idea behind the Digital Twin concept is to make a purely electronic version of a product. For example, you sell a motor. That specific motor gets a digitized version that essentially acts as a record of everything that has happened to that individual model. If it breaks down and gets repaired in the field, or it gets sent in to be rewound, that gets marked in the digital twin. It serves as blueprint, case file and, when looked at alongside other twins, another form of data analysis all in one.

Meanwhile, Siemens is developing MindSphere, a cloud-based IIoT system that brings Siemens’ high-end analytics and applications to bear.

“MindSphere is Siemens’ open IIoT operating system that



The amount of data companies have access to is increasing by orders of magnitude, making it more important than ever to utilize PLM software to organize that data.

is used to bring real world product performance data back to be merged with the digital twin to support predictive analytics to improve products and support,” Lewis said.

According to Wrenn, most companies wait until they “start to see problems in product development, in cost of goods sold, or in quality.” But the flood of fresh data that many manufacturers now have access to is impossible to go through by hand. In order to take advantage of all that information, a strong PLM program that can sort through it all is more imperative to remaining competitive than ever.

“We say that the Internet of Things is going to cause a lot of manufacturers to start to clean up their digital life. This is the time for people to really take their digital strategy, inclusive of CAD, ALM and PLM, more seriously,” Wrenn said. “The requirement for winning in the world of IoT is being digital.”

So let’s say you’re convinced; it’s time to start a PLM program. What are your options? Where do you start? According to Wrenn, you’ve got a number of options. You could go wild and go for the full makeover, which has worked for some companies in the past, but is also expensive and most likely disruptive. The safer route is to incrementally implement PLM strategies into your business.

“Probably the most common one is for people to wade their way in functionally,” Wrenn said.

Working this way, manufacturers often start with one step of their process, be it developing their CAD program, managing bill materials, or something else entirely, then implement PLM best practices and technology across the entire company for just that single step. Once you’ve comfortably implemented one step, you can look elsewhere and slowly go through your entire process one function at a time.

Another way is to use the same incremental implementation, but go by product instead of manufacturing step. Pick a single product line and utilize PLM in every step of that line’s manufacturing process. Then, after you’ve seen the results, think about doing the same with other products until you’ve covered your full portfolio.

Each process has worked for other companies in the past, but according to Wrenn, the best path forward is usually self-evident once you sit down and take a look at your busi-

With a PLM database centralizing your data, it’s easier to make sure that everyone in your company is on the same page.



ness. Look for pain points or areas in your process where you struggle or, alternatively, opportunities you want to follow up on. Once you’ve established your strengths and weaknesses, figure out which you want to address first, then find the PLM solution that fulfills that need.

Lewis also feels that most companies can find one or two obvious places to start if they focus on where they’re struggling, looking for processes that need shoring up. But if you’re still coming up short after some soul searching, Siemens can probably point you in the right direction as you strategically plan your transition into the digital world. They have experience working with businesses in the energy, transportation and industrial machinery sectors to implement PLM strategies and have a good idea of what’s worked and what hasn’t.

“We’ve worked with a lot of companies, and realistically, we can point to where they can probably find problems, inefficiencies, and so on...This is a guided adoption because we’ve developed best practices based on how hundreds of companies have achieved success,” Lewis said. “So, with guidance, we can point out where we can improve processes, where we can expect savings, etc.

“There are some logical places with which it makes sense to begin. Getting processes and key data under control. You know, some of the primary IP for a product is the product’s bill of materials, the engineering documentation, the CAD definitions, and so

on. Getting that under control gives companies a great starting point to begin extending the value of their PLM system upstream and downstream. This is exactly how we envision people adopting Teamcenter, starting with getting some key things under control, and expanding from there. With the

**“This is the time for people to really take their digital strategy, inclusive of CAD, ALM and PLM, more seriously. The requirement for winning in the world of IoT is being digital.”**

— Kevin Wrenn, divisional general manager of PLM and ALM segments, PTC

digital backbone in place, you can build on to it with deeper domain solutions such as systems engineering, ALM, cost management, product validation and verification, etc., or extend the lifecycle with service lifecycle management expanding the knowledge in your digital twin as makes sense for your company.”

**“Even if you’re not the ultimate company that delivers to the customer, PLM is important for seamless collaboration.”**

– Kevin Wrenn, divisional general manager of PLM and ALM segments, PTC

Getting your company’s data sorted out first makes sense. Having a single, centralized knowledge base that the entire company can access creates a foundation that makes it easier to implement other, more complex PLM products such as some of the ones PTC offers. One challenge that manufacturers might wrestle with, however, is what to do with their legacy data. When putting together a PLM program, it might be difficult to sort through all the unorganized data you already might have lying around, but both Wrenn and Lewis agree that it’s worth it to use legacy data.

“What we probably see more of now is a migrate-on-demand scenario,” Lewis said. “So, leave the legacy data where it is. New programs or projects start in PLM. Then, when some legacy data is identified as being needed, it gets migrated and carried forward in the new PLM system. This way, we are only spending resources on migrating what we need.”

The most important thing to remember is that your PLM program can always be expanded. Even after establishing a solid base and some best practices, there will always be more opportunities to seize and more capabilities to invest in.

“Many use [PLM] already, but often they are only using portions of it,” Lewis said. “There is a lot of opportunity out there to leverage PLM both upstream and downstream in their processes.”

And if the new implementations at PTC are anything to go by, those opportunities will only multiply. How much you take advantage of PLM products is entirely dependent on how far down the rabbit hole you decide to go. Once you get started, there will always be a breadcrumb trail to follow, and the question will eventually become: how far will you pursue it? **PTE**

#### For more information:

PTC  
Phone: (877) 275-4782  
[www.ptc.com](http://www.ptc.com)

Siemens PLM Software  
Phone: (800) 498-5351  
[www.plm.automation.siemens.com](http://www.plm.automation.siemens.com)

For Related Articles Search

PLM

at [www.powertransmission.com](http://www.powertransmission.com)



## BROWSE OUR BLOGS!

PTE features three blogs to keep readers updated on the latest PT trends, technologies and industry solutions:

**Bearings with Norm:** Norm Parker is the bearing technical specialist for the driveline division at General Motors LLC and offers various insights and technical knowledge on the bearing industry.

**Motor Matters with George Holling:** The technical director at Rocky Mountain Technologies regularly contributes articles regarding motors, power quality, power factor, efficiency and more.

**Editor’s Choice:** Our editorial staff provides relevant and timely articles on a variety of PT industrial topics.

Visit

[www.powertransmission.com/blog/](http://www.powertransmission.com/blog/) to learn more.

# Hands-On Hydraulics & Pneumatics

## Action Challenge Introduces Students to Fluid Power Industry

Matthew Jaster, Senior Editor

### It begins with a box of parts.

Middle school students (working in teams of four) receive a basic tool kit and are tasked with building a prototype machine using fluid power to move and rotate objects from one area to another. This might take place on steps or on a platform, according to Lynn Beyer, director of workforce development programs at the National Fluid Power Association (NFPA).

“The setup and the challenge scenario change for every new event. The most important aspect of the competition is that the students learn a little and have some fun in the process,” she said.

There are many different Science, Technology, Engineering and Math (STEM) educational programs and competitions available to students today, but few focus specifically on fluid power.

“With the NFPA Fluid Power Action Challenge, students learn about problem-solving, teamwork and perseverance,” Beyer said. “And our members get an opportunity to promote this industry to potentially the next generation of fluid power engineers.”

### All Things Fluid Power

Fluid power is a term that describes both hydraulic and pneumatic technologies. Both technologies use a fluid (liquid or gas) to transmit power from one location to another. With hydraulics, the fluid is a liquid (usually oil), whereas pneumatics uses a gas (usually compressed air). Both are forms of power transmission. They are just slightly different than the gears, chains, belts and other mechanical drives typically found in the pages of *Power Transmission Engineering*.

The NFPA website states that although they’re viewed as competing technologies, no single method of power transmission (mechanical, electrical or fluid power) is the best choice for all applications. In fact, most applications are served by a combination of technologies.

There are, however, many advantages to fluid power systems. For starters, they can transmit equivalent power within a smaller space than mechanical or electric drives. They also offer speed, force, torque and control of direction using simple valves. Fluid power systems often do not require electrical power, which eliminates the risk of electrical shock, fire, or explosions.

And most importantly, for the context of this particular article, fluid power devices make a great educational tool for budding engineers and manufacturers. The idea for the

Fluid Power Action Challenge was a calling card of sorts for associations, manufacturing partners and educational institutions to spread the word on fluid power technology.

The contest was originally created by the Canadian Fluid Power Association to develop fluid power theories in the classroom and provide students with hands-on kits to build simple fluid power devices for an engineering competition.

“Steve Rogers, Mechanical Kits Ltd., came up with the kits in order to introduce students to these concepts. Today, Rogers continues to change the kit design for each new fluid power competition,” Beyer added.

In 2008, the NFPA, headquartered in Milwaukee, Wisconsin, began introducing challenges here in the United States (14 events in Wisconsin). Last year, more than 3,623 students were introduced to fluid power according to Arlen Garcia, workforce manager at NFPA.



Milwaukee School of Engineering hosts an NFPA Fluid Power Action Challenge.

“We’re continually promoting these events and trying to spread the word on the fluid power industry,” Beyer said. “At the same time, it’s important to get our own members involved. We’re extremely excited about the growth potential.”

The NFPA launched a new website for the Fluid Power Challenge in June 2016. On the website, users can learn about the three different challenges based on different age groups: The Fluid Power Action Challenge, Fluid Power Robotics Challenge and the Fluid Power Vehicle Challenge. While this article will focus on the Action Challenge, here’s a quick breakdown of the two other programs currently offered:



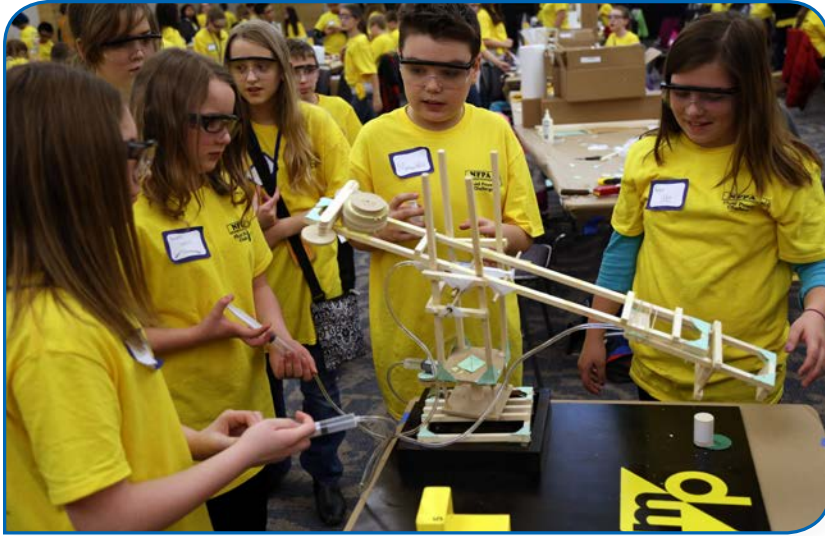

Students in Macomb County, Michigan participate in the NFPA Fluid Power Action Challenge in 2016.

The Robotics Challenge is a scholarship program new this year. The NFPA will be offering one merit-based scholarship (\$10,000 per year for four years) to high school seniors who have participated in a 2017 *FIRST* Robotics Competition Team ([www.firstinspires.org](http://www.firstinspires.org)).

The NFPA Fluid Power Vehicle Challenge is a new program based on an initiative pioneered by the Parker Hannifin Corporation. This STEM competition challenges college engineering students to redesign a traditional bicycle using hydraulics as the mode of power transmission.

### The Action Challenge

The NFPA Fluid Power Action Challenge is a competition that challenges middle school students to solve an engineering problem by assembling a fluid power machine. Students work in teams to design and build the machine and then compete with other teams in a timed competition. The competition is broken up into two days: A Workshop Day and a Challenge Day.

#### Workshop Day

“On the first day, students watch a video to learn about the basics of fluid power,” Beyer said. “They also get the chance to learn the cool things they can do with a career in fluid power.”

Next, students put together very basic fluid power kits. “They learn how water can move through the parts they are building and start working on machines that rotate and even lift objects,” she added. “This is where we first introduce practical fluid power methods and applications.”

The Workshop Day wraps up by giving the students the Action Challenge. This is the engineering problem they must solve by developing a plan and building a prototype machine that will compete against other teams. The students have four to six weeks to prepare for the competition.

#### Challenge Day

On Challenge Day, the teams come back together for the official competition. They utilize the same tools and an

identical kit of supplies to recreate their unique machines. Working as a team, the students build the device in an allotted timeframe. Teams are judged on their portfolio, design, teamwork and total machine points.

As the teams work, the judges observe and interview students, asking questions about their designs and how they work together as a team. When the time limit is reached, the teams put their machines to the test and the judges score how well the machines perform the designated task.

### Master Pneumatic — Year Three

The scenario went something like this: Your team of highly trained experts in the field of material handling has been commissioned to design a controlled pneumatic or hydraulic device that will safely move containers of “highly toxic materials” between storage areas.

Teams are instructed to build a device that picks up the containers and deposits said containers to a designated area. All movements of the device must be controlled using fluid power. Teams will transport as many containers as possible between the two areas in a two-minute time frame.

Thus began Master Pneumatic’s third venture into the NFPA Fluid Power Action Challenge. The company recently hosted 108 sixth-grade students at Macomb Community College, located in Warren, Michigan, for the Workshop Day portion of the event. Since this competition is geared more towards seventh- and eighth-graders, the rules were bent ever so slightly to accommodate the sixth-grade students.

“We’re always impressed with the students that participate in these events. It’s worth all the energy, time and effort when a team of students put together their machine and that light bulb comes on. This is what makes it so rewarding,” said Cathy Meyer, engineering assistant and customer service at Master Pneumatic.

The key to running a successful Fluid Power Action Challenge is get as many people involved as possible, Meyer added. “Our president was excited about the opportunity to go out into the community and talk about fluid power. It starts at the top. You also need great sponsors and great volunteers, people that are committed to helping these kids learn.”

Even some of Master Pneumatic’s local competition turns up each year to volunteer their time. “They’re always asking how they can help and if they can come back the following year and participate in the next event,” Meyer said. “It’s fulfilling to see such a positive response throughout the community.”

Meyer received positive feedback from both teachers and students once they wrapped the first day of the event

in January. “These kids are learning skills that involve math, science, engineering, manufacturing, problem-solving, etc. during the competition. They’re putting together a nice knowledge base that will help them no matter what career they choose down the road,” she added.

Now that the Workshop Day is over, the students will return to Macomb Community College on March 28 for Challenge Day. The teams will have two hours to construct their robotic devices. Just two hours to prove they can move the most containers from Point A to Point B. “The Challenge Day gives us a real sense of how far they’ve come,” Meyer said. “It’s a lot of fun to see the progress these students make and what they take away from the competition.”

### How to Get Involved

These educational programs would not be possible without the volunteers and the assistance of NFPA member companies. Beyer believes that the more involved the fluid power community gets, the better the industry is served long-term.

In order to run a successful challenge, three key roles must be filled by participating organizations (coordinator, facilitator and judge). The coordinator handles all the organizational details and logistics of the event, the facilitator runs the Workshop and Challenge Days and the judge (4-6 judges for every 20 teams of competing students) must work in the industry and must be knowledgeable about fluid power. The head judge will calculate totals and assign other judges to specific tasks.

“We welcome volunteers and encourage organizations to team up with local school districts and present these



Parker Hannifin hosts an Action Challenge event and is also involved in the NFPA Fluid Power Vehicle Challenge.

various programs to students,” Beyer said. “As industry and government come together to help solve the skilled labor shortage, these competitions continue to be a great resource to attract kids to manufacturing and engineering positions.”

Companies and institutions involved in the Fluid Power Action Challenge in 2017 include Force America, Daman Products, Parker Hannifin, Master Pneumatic, Caterpillar, Price Engineering, Wojanis, Jarp, Deltrol Fluid Products, Milwaukee School of Engineering, Cleveland Community College, Purdue University and more.

Beyer said that participating companies can host a private action challenge or a public challenge that includes additional schools and organizations.

So what’s the best way to get involved? Simply contact Beyer at the NFPA. “We have detailed instructions on the website and I can certainly help anyone get started,” she said.

By creating a variety of fluid power programs, Beyer hopes that many of the young students that get involved in the Action Challenge stick with STEM activities.

“We hope that the middle school kids go on to participate in the robotics challenge in high school and then the vehicle challenge in college,” she said. “This is a great opportunity to keep students engaged in fluid power throughout the course of their education.” **PTE**

#### For more information:

Master Pneumatic  
Phone: (877) 240-1005  
[www.masterpneumatic.com](http://www.masterpneumatic.com)

NFPA  
Phone: (414) 778-3344  
[www.nfpa.com](http://www.nfpa.com)



Master Pneumatic hosts the Action Challenge each year hoping to spread the word on fluid power and get the community more involved in STEM activities.

For Related Articles Search

fluid power

at [www.powertransmission.com](http://www.powertransmission.com)

# REGISTER NOW & SAVE \$200 (UNTIL MARCH 22)



## Attend. Learn. Apply.

### WHAT IS RELIABLE PLANT?

When you think about how your plant or workplace could improve, what comes to mind? Better procedures? Better communication? Better products? Answers to these questions are waiting for you at the 18th annual Reliable Plant Conference & Exhibition. Join us in Columbus, Ohio, to meet with industry leaders, exhibitors and fellow attendees who understand and experience your challenges. You'll learn key elements of reliability, new applications and fresh leadership ideas to make improvements last. **Don't settle for "good enough" machine reliability. Solve it with attainable solutions and results you will find at Reliable Plant 2017.**

### WHAT YOU'LL GET

- > All conference sessions and proceedings
- > 7+ networking events
- > Opening general session and keynote address
- > 3-day access to the 100,000 square-foot exhibit hall
- > Breakfasts, lunches and refreshment breaks
- > One FREE Noria training voucher (valued at \$1,295)

ENTER FOR YOUR CHANCE TO

# WIN! A SEA-DOO SPARK

### NEW FOR 2017

- > 90+ Sessions and Counting
- > 100+ Exhibitors
- > 30+ Case Studies
- > Four Certificate Programs
- > 6 Workshops
- > Roundtable Discussion
- > 6 Mini-Workshops
- > Plus Much More!

APRIL 25-27  
**2017**  
COLUMBUS, OH

To learn more or register,  
call 800-597-5460 or visit  
[Conference.ReliablePlant.com](http://Conference.ReliablePlant.com)

**RELIABLEPLANT** 2017  
CONFERENCE & EXHIBITION



**Nordex**  
INCORPORATED

Over 32,000 standard components.

Buy online 24/7.

**Nordex.com**



**Turner Uni-Drive**  
Manufacturers of Industrial Transmissions,  
Speed Reducers & Gearboxes

[www.turnerunidrive.com](http://www.turnerunidrive.com)



Catalog Multi-speed

Custom Design

OEM Manufacturing

- **Standard catalog and custom engineered gearboxes**
- **1 HP to 1000 HP**
- **Gearbox repair**
- **Reverse Engineering**

**Turner Uni-Drive** Phone: 816-931-6001 | Toll Free Phone: 800-637-7736  
3434 Terrace Street | Kansas City, MO 64111 Fax: 816-931-6055



**B&R**  
MACHINE AND GEAR CORP

**BRGEAR.COM**

## Planetary Gearheads

The Sesame series offers a wide range of performance levels, configurations, and mounting options.



- Frame sizes from 42 - 220 mm
- Precision and economy models
- Round or square face mounting
- Ratios from 3:1 to 1000:1

**DIEQUA**  
Corporation

[www.diequa.com](http://www.diequa.com)

630-980-1133

## Precision Positioning

The Spinea cycloidal reducer offers superior precision and performance over harmonic flex splines.

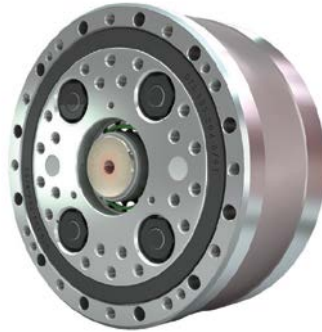

- Sizes from 50 - 140 mm
- Zero Backlash
- Higher Torque Density
- Higher Tilting Capacity
- Higher Torsional Rigidity

**DIEQUA**  
Corporation

[www.diequa.com](http://www.diequa.com)

630-980-1133

## Engineering sMART

is your resource for the latest in great ideas from our advertisers. Check this section every issue for sMART Engineering ideas and technology.

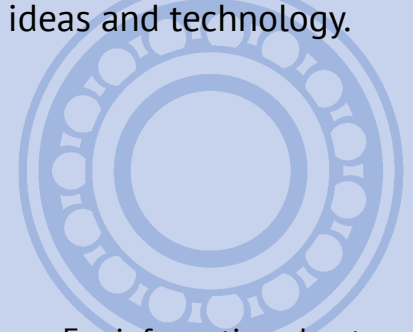

For information about advertising, contact Dave Friedman

at

**(847) 437-6604**

or

[dave@powertransmission.com](mailto:dave@powertransmission.com).

## Power Transmission Engineering online!

It's like your own professional superpower.

Stronger, faster and smarter than your average website, [www.powertransmission.com](http://www.powertransmission.com) offers everything you need to supercharge your engineering-oriented organization.

- Complete archive of articles on engineered components
- Directory of suppliers of gears, bearings, motors and other mechanical power transmission components
- Product and Industry News updated daily
- Exclusive online content in our e-mail newsletters
- The Bearings Blog
- Calendar of upcoming events
- Comprehensive search feature helps you find what you're looking for — *faster than a speeding bullet!*



[www.powertransmission.com](http://www.powertransmission.com)

# How to Prevent Pulley Slippage

## THE QUESTION

I'm not able to get a good connection between the pulley and shaft in my drive assembly. Could you explain the various ways of connecting a pulley to a shaft to prevent the pulley from slipping?

**Expert response provided by SDP/SI:** There are a variety of methods used to attach pulleys to shafts. Knowing the advantages and disadvantages of each one will help you make a better choice when installing drive components into your assembly. Using the appropriate method for your application can go a long way in preventing damage and possible equipment failure. Consideration should also be given to field service needs.

Controlled tolerances between the shaft and pulley prevent slipping and can be achieved through various mounting devices or fastening methods.

Types of connections between shaft and pulley:

- Set-screw
- Fairloc
- Press-fit
- Shaft-lock
- Shaft extenders
- Clamp

**Structure: advantages and disadvantages of each:**

**Set-screw type connection** is a simple, inexpensive way to connect a pulley to a shaft. The pulley requires an additional extension (Hub) on which, perpendicular to the direction of the shaft a hole or holes are drilled and tapped.

Drilling and tapping can be performed on any type of material the pulley is made of, most common are aluminum, stainless steel, steel, and plastics with a metal or reinforced hub.

**Disadvantages:** requires additional axial space because of the hub's projection; torque transmission is limited in comparison to press-fit and shaft lock types. In addition, different types of set screw tips can damage the surface of the shaft.

**Fairloc type** is an easy way to connect the pulley to the shaft.

Two slots are machined into the hub — one oriented radially, the other angularly — to create a transverse wedge which remains attached to the solid portion of the hub on one side. The resultant cantilevered clamping section has a tapped



Figure 1 Set-screw type connection is a simple, inexpensive way to connect pulley to shaft.

hole to accept a cap screw which passes through a clearance hole in the solid portion of the hub, and into a threaded hole in the transverse wedge section. As the screw is tightened, the cantilevered section clamps the shaft securely.

The compact, self-contained design reduces misalignment and can be tightened and released repeatedly without marring the shaft. Produced in stainless steel, aluminum and brass, it is well suited for applications that require moderate torque and speed. For optimal performance Fairloc hubs require controlled tolerances between the shaft and pulley (suggested clearance fit .0001"/.0008"). For high-torque/high-speed applications, shaft locks are a better option.

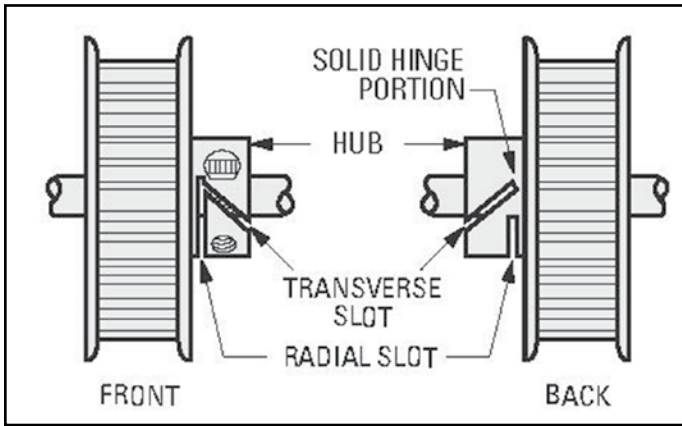

Figure 2 Fairloc type is an easy way to connect pulley to shaft.

**Press fit type**, especially for metal on metal, is a good option for applications requiring tight concentricity/runout. This method performs well in low/moderate torque (20–30 lbs × in.) applications, even for high rotational speeds. Good for devices where space constraint is a concern.

**Disadvantages:** requires very precise tolerances on the bore of the pulley and on the pilot surface of the shaft. Not all combinations of materials provide the same torque capacity of the press fit.

**Shaft lock type** is a very robust way to connect a pulley to a shaft; good for high-speed applications as well. It is recommended for mechanisms where axial space is of concern; doesn't require extremely precise tolerances on the pilot surfaces. These devices are made of various types of metals (steel is preferred).

**Disadvantages:** a more expensive option (requires additional component, the shaft lock). Some of the shaft lock devices, especially the heavy duty ones, are not easily installed and even more difficult to uninstall.

**Shaft extenders** are used where large axial distances between components need to be compensated. When produced in stainless steel they provide the best performance for high-torque (70–80 lbs × in.) and high-speed applications.

**Disadvantages:** requires high precision shafting and very tight concentricity between bore and the shaft O.D.

**Clamp type** requires additional clamp to connect a split hub pulley and a shaft. Clamps come in a variety of configurations; balanced clamps are used for high-torque applications.

**Disadvantage:** additional component—the clamp. Requires controlled tolerances on pilot surfaces, some of the constructions are difficult to assemble. Usage of clamps has declined as easier to use connecting methods have been developed.

**Applications:**

**Set-screw:** in mechanisms used for shop manual tools

**Fairloc:** aerospace, avionics, medical, printing, scanning devices

**Shaft lock:** power tools, oil industry

**Shaft extenders:** drilling devices



Figure 3 Shaft lock type is robust way to connect pulley to shaft; good for high-speed applications as well.

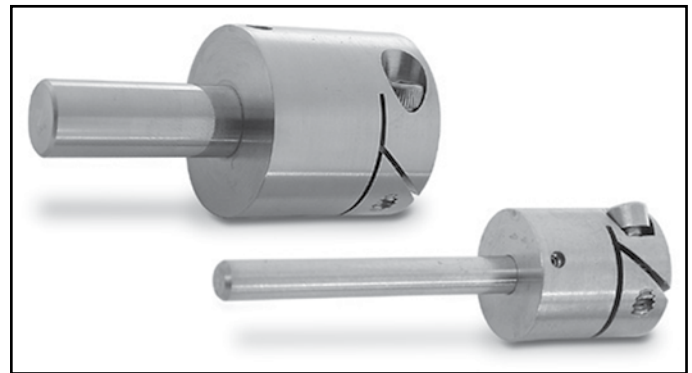

Figure 4 Shaft extenders are used where large axial distances between components need to be compensated.

When attaching the pulley to the shaft you have a number of choices; one method may work better in your application than another. It is important to have a basic understanding of your drive system and keep the following points in mind: torque and speed requirements, accessibility, material and cost.

**SDP/SI** (Stock Drive Products/Sterling Instrument) provides mechatronic-based design, engineering and manufacturing services for industrial and commercial applications. Contact: [sdp-sisupport@sdp-si.com](mailto:sdp-sisupport@sdp-si.com).

For Related Articles Search

belt drives

at [www.powertransmission.com](http://www.powertransmission.com)

# Baldor Basics: Motors

Edward Cowern, P.E.

A continuing series of articles, courtesy of the Baldor Electric Co., dedicated primarily to motor basics; e.g. — how to specify them; how to operate them; how — and when — to repair or replace them, and considerably more. Stay tuned!

THIS ISSUE:

The Mystery of Motor Frame Size  
Primer on Two-Speed Motors

## Introduction

Industrial electric motors have been available for nearly a century. In that time there have been a great many changes. One of the most obvious has been the ability to pack more horsepower in a smaller physical size. Another important achievement has been the standardization of motors by the National Electric Manufacturers Association (NEMA).

A key part of motor interchangeability has been the standardization of frame sizes. This means that the same horsepower, speed, and enclosure will normally have the same frame size from different motor manufacturers. Thus, a motor from one manufacturer can be replaced with a similar motor from another company provided they are both in standard frame sizes.

## Three Generations

The standardization effort over the last forty-plus years has resulted in one original grouping of frame sizes called “original.” In 1952, new frame assignments were made. These were called “U frames.” The current “T frames” were introduced in 1964. “T” frames are the current standard and most likely will continue to be for some time in the future.

Even though “T” frames were adopted in 1964, there are still a great many “U” frame motors in service that will have to be replaced in the future. Similarly there are also many of the original frame size motors (pre-1952) that will reach the end of their useful life and will have to be replaced. For this reason it is desirable to have reference material available on frame sizes and some knowledge of changes that took place as a part of the so-called re-rate programs.

## Frame Size Reference Tables

Tables 1 and 2 show the standard frame size assignments for the three different eras of motors. As you will note, these tables are broken down for open drip proof (Table 1) and totally enclosed (Table 2). You will also find that for each horsepower rating and speed, there are three different frame sizes — first is the original frame size; the middle one is the “U frame” size; and the third one is the “T frame.” These are handy reference tables since they give general information for all three vintages of three-phase motors in integral horsepower frame sizes.

One important item to remember is that the base mounting hole spacing (“E” and “F” dimensions) and shaft height (“D” dimension) for all frames having the same three digits — regardless of vintage — will be the same.

## Rerating and Temperatures

The ability to re-rate motor frames to get more horsepower in a frame has been brought about mainly by improvements made in insulating materials. As a result of this improved insulation, motors can now be run much hotter. This allows more horsepower in a compact frame. For example, the original NEMA frame sizes ran at very low temperatures. The “U” frame motors were designed for use with Class A insulation, which has a rating of 105°C. The motor designs were such that the capability would be used at the hottest spot within the motor. “T” frame motor designs are based on utilizing Class B insulation with a temperature rating of 130°C. This increase in temperature capability made it possible to pack more horsepower into the same size frame. To accommodate the larger mechanical horsepower capability, shaft and bearing sizes had to be increased. Thus, you will find that the original 254 frame (5 HP at 1,800 RPM) has a 1 $\frac{1}{8}$ " shaft. The 254U frame (7 $\frac{1}{2}$  HP at 1,800 RPM) has a 1 $\frac{3}{8}$ " shaft, and the current 254T frame (15 HP at 1800 RPM) has a 1 $\frac{5}{8}$ " shaft. Bearing diameters were also increased to accommodate the larger shaft sizes and heavier loads associated with the higher horsepower.

## Frame Size Basis

On page 14 you will find a Baldor frame size chart that is a great reference on “T” frame, “U” frame and original frame motors. Most of the dimensions are standard dimensions that are common to all motor manufacturers. One exception to this is the “C” dimension (overall motor length) which will change from one manufacturer to another.

## Fractional Horsepower Motors

The term “fractional horsepower” is used to cover those frame sizes having two-digit designations as opposed to the three-digit designations that are found in Tables 1 and 2. The frame sizes that are normally associated with industrial fractional horsepower motors are 42, 48, and 56. In this case, each frame size designates a particular shaft height, shaft diameter, and face or base mounting hole pattern. In these motors specific frame assignments have not been made by horsepower and speed, so it is possible that a particular horsepower and speed combination might be found in three different frame sizes. In this case, for replacement it is *essential that the frame size be known as well as the horsepower, speed and enclosure*. The derivation of the two-digit frame number is based on the shaft height in sixteenths of an inch.



Table 1 Open Drip-Proof												
THREE PHASE FRAME SIZES - GENERAL PURPOSE												
RPM NEMA Program HP	Orig.	3600 1952 Rerate	1964 Rerate	Orig.	1800 1952 Rerate	1964 Rerate	Orig.	1200 1952 Rerate	1964 Rerate	Orig.	900 1952 Rerate	1964 Rerate
1				203	182	143T	204	184	145T	225	213	182T
1.5	203	182	143T	204	184	145T	224	184	182T	254	213	184T
2	204	184	145T	224	184	145T	225	213	184T	254	215	213T
3	224	184	145T	225	213	182T	254	215	213T	284	254U	215T
5	225	213	182T	254	215	184T	284	254U	215T	324	256U	254T
7.5	254	215	184T	284	254U	213T	324	256U	254T	326	284U	256T
10	284	254U	213T	324	256U	215T	326	284U	256T	364	286U	284T
15	324	256U	215T	326	284U	254T	364	324U	284T	365	326U	286T
20	326	284U	254T	364	286U	256T	365	326U	286T	404	364U	324T
25	364S	286U	256T	364	324U	284T	404	364U	324T	405	365U	326T
30	364S	324US	284TS	365	326U	286T	405	365U	326T	444	404U	364T
40	365S	326US	286TS	404	364U	324T	444	404U	364T	445	405U	365T
50	404S	364US	324TS	405S	365US	326T	445	405U	365T	504	444U	404T
60	405S	365US	326TS	444S	404US	364T	504	444U	404T	505	445U	405T
75	444S	404US	364TS	445S	405US	365T	505	445U	405T	—	—	444T
100	445S	405US	365TS	504S	444US	404T	—	—	444T	—	—	445T
125	504S	444US	404TS	505S	445US	405T	—	—	445T	—	—	
150	505S	445US	405TS	—	—	444T	—	—		—	—	
200			444TS	—	—	445T	—	—		—	—	
250			445TS	—	—		—	—		—	—	

Table 2 Totally Enclosed, Fan-Cooled												
THREE PHASE FRAME SIZES - GENERAL PURPOSE												
RPM NEMA Program HP	Orig.	3600 1952 Rerate	1964 Rerate	Orig.	1800 1952 Rerate	1964 Rerate	Orig.	1200 1952 Rerate	1964 Rerate	Orig.	900 1952 Rerate	1964 Rerate
1				203	182	143T	204	184	145T	225	213	182T
1.5	203	182	143T	204	184	145T	224	184	182T	254	213	184T
2	204	184	145T	224	184	145T	225	213	184T	254	215	213T
3	224	184	182T	225	213	182T	254	215	213T	284	254U	215T
5	225	213	184T	254	215	184T	284	254U	215T	324	256U	254T
7.5	254	215	213T	284	254U	213T	324	256U	254T	326	284U	256T
10	284	254U	215T	324	256U	215T	326	284U	256T	364	286U	284T
15	324	256U	254T	326	284U	254T	364	324U	284T	365	326U	286T
20	326	286U	256T	364	286U	256T	365	326U	286T	404	364U	324T
25	365S	324U	284TS	365	324U	284T	404	364U	324T	405	365U	326T
30	404S	326US	286TS	404	326U	286T	405	365U	326T	444	404U	364T
40	405S	364US	324TS	405	364U	324T	444	404U	364T	445	405U	365T
50	444S	365US	326TS	444S	365US	326T	445	405U	365T	504	444U	404T
60	445S	405US	364TS	445S	405US	364T	504	444U	404T	505	445U	405T
75	504S	444US	365TS	504S	444US	365T	505	445U	405T	—	—	444T
100	505S	445US	405TS	505S	445US	405T	—	—	444T	—	—	445T
125			444TS	—	—	444T	—	—	445T	—	—	
150			445TS	—	—	445T	—	—		—	—	

# BALDOR

A MEMBER OF THE ABB GROUP

Leading Provider of Energy Efficient Industrial Electric Motors and Drives

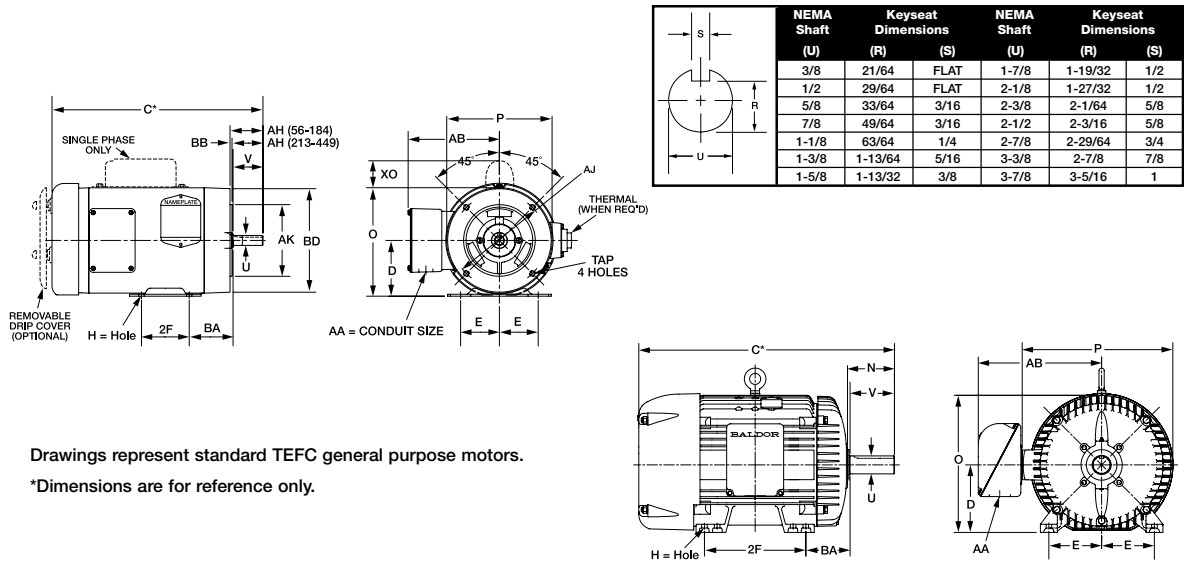

Drawings represent standard TEFC general purpose motors.  
 \*Dimensions are for reference only.

\*Contact your local Baldor Sales Office for "C" Dimensions.

Dimensions - N, O, P, AB and XO are specific to Baldor.

## NEMA QUICK REFERENCE CHART

NEMA FRAME	D	E	2F	H	N	O	P	U	V	AA	AB	AH	AJ	AK	BA	BB	BD	XO	TAP
42	2-5/8	1-3/4	1-11/16	9/32 SLOT	1-1/2	5	4-11/16	3/8	1-1/8	3/8	4-1/32	1-5/16	3-3/4	3	2-1/16	1/8	4-5/8	1-9/16	1/4-20
48	3	2-1/8	2-3/4	11/32 SLOT	1-7/8	5-7/8	5-11/16	1/2	1-1/2	1/2	4-3/8	1-11/16	3-3/4	3	2-1/2	1/8	5-5/8	2-1/4	1/4-20
56 56H	3-1/2	2-7/16	3	11/32 SLOT	2-7/16	6-7/8	6-5/8	5/8	1-7/8	1/2	5	2-1/16	5-7/8	4-1/2	2-3/4	1/8	6-1/2	2-1/4	3/8-16
143T 145T	3-1/2	2-3/4	4	11/32	2-1/8	6-7/8	6-5/8	7/8	2-1/4	3/4	5-1/4	2-1/8	5-7/8	4-1/2	2-1/4	1/8	6-1/2	2-1/4	3/8-16
182 184 182T 184T	4-1/2	3-3/4	4-1/2	13/32	2-11/16	8-11/16	7-7/8	7/8	2-1/4	3/4	5-7/8	2-1/8	5-7/8	4-1/2	2-3/4	1/8	6-1/2	2-3/8	3/8-16 1/2-13
213 215 213T 215T	5-1/4	4-1/4	5-1/2	13/32	3-1/2	10-1/4	9-9/16	1-1/8	3	1	7-3/8	2-3/4	7-1/4	8-1/2	3-1/2	1/4	9	2-3/4	1/2-13
254U 256U 254T 256T	6-1/4	5	8-1/4	17/32	4-1/16	12-7/8	12-15/16	1-3/8	3-3/4	1	9-5/8	3-1/2	7-1/4	8-1/2	4-1/4	1/4	10	-	1/2-13
284U 286U 284T 286T 284TS 286TS	7	5-1/2	9-1/2	17/32	5-1/8	14-5/8	14-5/8	1-5/8	4-7/8	1-1/2	13-1/8	4-7/8	9	10-1/2	4-3/4	1/4	11-1/4	-	1/2-13
324U 326U 324T 326T 324TS 326TS	8	6-1/4	10-1/2	21/32	5-7/8	16-1/2	16-1/2	1-7/8	5-5/8	2	14-1/8	5-3/8	11	12-1/2	5-1/4	1/4	13-3/8	-	5/8-11
364U 365U 364T 365T 364TS 365TS	9	7	11-1/4	21/32	6-3/4	18-1/2	19-1/2	2-1/8	6-3/8	3	18	6-1/8	11	12-1/2	5-7/8	1/4	13-3/8	-	5/8-11
404U 405U 404T 405T 404TS 405TS	10	8	12-1/4	13/16	7-3/16	21-5/16	22-1/2	2-3/8	7-1/8	3	19-1/4	6-7/8	11	12-1/2	6-5/8	1/4	13-7/8	-	5/8-11
444U 445U 444T 445T 447T 449T 444TS 445TS 447TS 449TS	11	9	14-1/2	13/16	8-5/8	24.24	27.57	2-7/8	8-5/8	3	22.68	8-3/8	14	16	7-1/2	1/4	16-3/4	-	5/8-11

The above chart provides typical Baldor-Reliance motor dimensions. For more exact dimensional data, please check the specific drawing for each catalog number. NEMA states only a minimum value for AA dimension. AA dimensions shown in chart are Baldor typical values meeting or exceeding NEMA. Please check motor drawing for actual dimensions.

Frame L449T is not included in this chart. Please refer to the Large AC motor chart, or to the specific motor drawings for L449T dimensions.

NEMA C-Face	BA Dimensions
143-5TC	2-3/4
182-4TC	3-1/2
213-5TC	4-1/4
254-6TC	4-3/4

BALDOR ELECTRIC COMPANY  
 P.O. BOX 2400  
 FORT SMITH, ARKANSAS  
 72902-2400 U.S.A.

Frame	NEMA FRAMES PRIOR TO 1953							
	D	E	F	N	U	V	BA	BA
66	4-1/8	2-15/16	2-1/2	2-1/4	3/4	2-1/4	3-1/8	3-1/8
203	5	4	3-3/4	2-7/16	3/4	2	3-1/8	3-1/8
224	5-1/2	4-1/2	3-3/8	3-1/4	1	3	3-1/2	3-1/2
225	6-1/4	5	4-1/8	3-7/16	1-1/8	3-3/8	4-1/4	4-1/4
254	7	5-1/2	4-3/4	4-1/4	1-1/4	3-3/4	4-3/4	4-3/4
324	8	6-1/4	5-1/4	5-3/8	1-5/8	4-7/8	5-1/4	5-1/4
326	8	6-1/4	5-1/4	5-3/8	1-5/8	4-7/8	5-1/4	5-1/4
364	9	7	5-5/8	5-5/8	1-7/8	5-3/8	5-7/8	5-7/8
365	9	7	5-5/8	5-5/8	1-7/8	5-3/8	5-7/8	5-7/8
404	10	8	6-1/8	6-3/8	2-1/8	6-1/8	6-5/8	6-5/8
405	10	8	6-1/8	6-3/8	2-1/8	6-1/8	6-5/8	6-5/8
444	11	9	7-1/4	7-1/4	2-3/8	6-7/8	7-1/2	7-1/2
445	11	9	7-1/4	7-1/4	2-3/8	6-7/8	7-1/2	7-1/2
504	12-1/2	10	8	8-5/8	2-7/8	8-3/8	8-1/2	8-1/2
505	12-1/2	10	8	8-5/8	2-7/8	8-3/8	8-1/2	8-1/2

You can figure that a 48-frame motor will have a shaft height of 48 divided by 16 or 3 inches. Similarly, a 56-frame motor would have a shaft height of 3½ inches. The largest of the current fractional horsepower frame sizes is a 56-frame that is available in horsepower greater than those normally associated with fractionals. For example, 56-frame motors are built in horsepower up to 3 HP and, in some cases, 5 HP. For this reason calling motors with 2-digit frame sizes “fractionals” is somewhat misleading.

### Integral Horsepower Motors

The term “integral-horsepower motor” generally refers to those motors having three-digit frame sizes such as 143T or larger. When dealing with these frame sizes one rule of thumb applies: the centerline shaft height (“D” dimension) above the bottom of the base is the first two digits of the frame size divided by four. For example, a 254T frame would have a shaft height of  $25 \div 4 = 6.25$  inches. Although the last digit does not directly relate to an “inch” dimension, larger numbers do indicate that the rear bolt holes are moved further away from the shaft end bolt holes (the “F” dimension becomes larger).

### Variations

In addition to the standard numbering system for frames, there are some variations that will appear; these are itemized below along with an explanation of what the various letters represent.

- C** Designates a “C” face (flange) mounted motor. This is the most popular type of face-mounted motor and has a specific bolt pattern on the shaft end to allow mounting. The critical items on “C” face motors are the “bolt circle” (AJ dimension), register (also called rabbet), diameter (AK dimension) and shaft size (U dimension). C flange motors always have threaded mounting holes in the face of the motor.
- D** The “D” flange has a special type of mounting flange installed on the shaft end; i.e. — the flange diameter is larger than the body of the motor and it has clearance holes suitable for mounting bolts to pass through from the back of the motor into threaded holes in the mating part. “D” flange motors are not as popular as “C” flange motors.
- H** Used on some 56-frame motors, “H” indicates that the base is suitable for mounting in either 56, 143T, or 145T mounting dimensions.
- J** This designation is used with 56-frame motors and indicates that the motor is made for “jet pump” service with a threaded stainless steel shaft and standard 56C face.
- JM** The letters “JM” designate a special pump shaft originally designed for a “mechanical seal;” this motor also has a C face.
- JP** Similar to the JM style of motor having a special shaft, the JP motor was originally designed for a “packing” type of seal. The motor also has a C face.
- S** The use of the letter “S” in a motor frame designates that the motor has a “short shaft.” Short shaft motors have shaft dimensions that are smaller than the shafts associated with the normal frame size. Short shaft motors are designed to be directly coupled to a load through a flexible

coupling. They are not intended for applications where belts are used to drive the load.

- T** “T” at the end of the frame size indicates that the motor is of the 1964 and later “T” frame vintage.
- U** A “U” at the end of the frame size indicates that the motor falls into the “U” frame size assignment (1952 to 1964) era.
- Y** When a “Y” appears as a part of the frame size it means that the motor has a special mounting configuration. It is impossible to tell exactly what the special configuration is, but it does denote that there is a special non-standard mounting.
- Z** Indicates the existence of a special shaft that could be longer, larger, or have special features such as threads, holes, etc. “Z” indicates only that the shaft is special in some undefined way.

(\* The NEMA chart provides typical Baldor•Reliance motor dimensions. For more exact dimensional data, please check the specific drawing for each catalog number. NEMA states only a minimum value for AA dimension. AA dimensions shown in chart are Baldor typical values meeting or exceeding NEMA. Please check motor drawing for actual dimensions.)

Frame L449T is not included in this chart. Please refer to the Large AC motor chart, or to the specific motor drawings for L449T dimensions.

### Primer On Two-Speed Motors

There seems to be a lot of mystery involved in two speed motors but they are really quite simple. They can first be divided into two different winding types:

**Two-speed, two-winding.** The two winding motor is made in such a manner that it is really two motors wound into one stator. One winding, when energized, gives one of the speeds. When the second winding is energized, the motor takes on the speed that is determined by the second winding. The two-speed, two-winding motor can be used to get virtually any combination of normal motor speeds and the two different speeds need not be related to each other by a 2:1 speed factor. Thus, a two-speed motor requiring 1,750 RPM and 1,140 RPM would, of necessity, have to be a two-winding motor.

**Two-speed, one-winding.** The second type of motor is the two-speed, single-winding motor. In this type of motor, a 2:1 relationship between the low and high speed must exist. Two-speed, single-winding motors are of the design that is called “consequent pole.” These motors are wound for one speed, but when the winding is reconnected the number of magnetic poles within the stator is doubled and the motor speed is reduced to one-half of the original speed. The two-speed, one-winding motor is, by nature, more economical to manufacture than the two-speed, two-winding motor. This is because the same winding is used for both speeds and the slots in which the conductors are placed within the motor do not have to be nearly as large as they would have to be to accommodate two separate windings that work independently. Thus, the frame size on the two-speed, single-winding motor can usually be smaller than on an equivalent two-winding motor.

**Load classification.** A second item that generates a good deal of confusion in selecting two speed motors is the load

classification for which these motors are to be used. In this case, the type of load to be driven must be defined and the motor is selected to match the load requirement.

The three types available are: *constant torque*, *variable torque*, and *constant horsepower*. For more details on load types please refer to "Understanding Torque" in this booklet.

**Constant torque.** Constant torque loads are those types of loads where the torque requirement is independent of speed. This type of load is the normally occurring load on such things as conveyors, positive displacement pumps, extruders, hydraulic pumps, packaging machinery, and other similar types of loads.

**Variable torque.** A second load type that is very different from constant torque is the kind of load presented to a motor by centrifugal pumps and blowers. In this case, the load torque requirement changes from a low value at low speed to a very high value at high speed. On a typical variable torque load, doubling the speed will increase the torque requirement by 4 times and the horsepower requirement by 8 times. Thus, on this type load, brute force must be supplied at the high speed and much reduced levels of horsepower and torque are required at the low speed. A typical two-speed, variable torque motor might have a rating of 1 HP at 1,725 and .25 HP at 850 RPM.

The characteristics of many pumps, fans, and blowers are such that a speed reduction to one-half results in an output at the low speed which may be unacceptable. Thus, many two-speed, variable-torque motors are made with a speed combination of 1,725/1,140 RPM. This combination gives an output from the fan or pump of roughly one-half when the low speed is utilized.

**Constant horsepower.** The final type of two-speed motor utilized is the two-speed, constant-horsepower motor. In this case the motor is designed so that the horsepower stays constant when the speed is reduced to the low value. In order to do this it is necessary for the motor's torque to double when it is operating in low-speed mode. The normal application for this type of motor is on metal working processes such as drill presses, lathes, milling machines, and other similar metal removing machines. The requirement for constant horsepower can perhaps be best visualized when you consider the requirements of a simple machine like a drill press. In this case, when drilling a large hole with a large drill, the speed is low but the torque requirement is very high. Compare that to the opposite extreme of drilling a small hole when the drill speed must be high but the torque requirement is low. Thus, there is a requirement for torque to be high when speed is low and torque to be low when speed is high. This is the "constant-horsepower" scenario.

The constant-horsepower motor is the most expensive two-speed motor. Three-phase, two-speed motors are quite

readily available in constant torque and variable torque. Two-speed, constant-horsepower motors are usually only available on a custom order basis.

**Two-speed, single-phase motors.** Two-speed, single-phase motors for constant torque requirements are more difficult to supply since there is a problem in providing a starting switch that will operate at the proper time for both speeds. Thus the normal two-speed, single-phase motor is offered as a variable-torque motor in a permanent-split capacitor configuration. The permanent-split capacitor motor has very low starting torque but is suitable for use on small, centrifugal pumps and fans.

## Summary

The use of two-speed motors in the future will grow quite rapidly as industrial motor users begin to realize the desirability of using this type of motor on exhaust fans and circulating pumps, so that air flow and water flow can be optimized to suit the conditions that exist in a plant or a process. Very dramatic savings in energy can be achieved by utilizing the two-speed approach. **PTE**

### For more information:

Baldor Electric Company/Member of the ABB Group  
5711 R. S. Boreham Jr. Street  
Fort Smith AR 72901  
Phone: (479) 648.5694  
[www.baldor.com](http://www.baldor.com)



For Related Articles Search

motor basics

at [www.powertransmission.com](http://www.powertransmission.com)

# **GREAT SCOTT!**

## ***It's the future!***

**OK, you blinked and missed last month's issue of *Power Transmission Engineering*.** Fortunately, you don't need a DeLorean to travel back in time — just a computer and working fingers.

Hop online and visit [www.powertransmission.com](http://www.powertransmission.com) to view the entire magazine, including these exclusive features:

- Getting a Piece of that Sweet Coupling Pie
- The Small Motor Rule — How Will it Affect You?
- Ask the Expert — Pre-tension Thrust Bearings
- Applications of Bevel Gears

**...and much more!**

[www.powertransmission.com](http://www.powertransmission.com)

# Lightweight, Highly Efficient Drive System

James Winchester, Andrea Favale and Scott A. Martin

This paper presents a joint project conducted by Ashwoods Electric Motors and Oerlikon Fairfield that uses planetary drives with an integrated electric motor. Current solutions used in production of off-highway vehicles rely upon large, heavy and inefficient brushed DC or induction motors, coupled to a planetary gearbox. This presents a number of challenges to the vehicle designers such as: limited vehicle range, limited space around the motor/drivetrain, and motor durability. The proposed integrated system utilizes an Oerlikon Fairfield Torque Hub, widely used in off-highway vehicles, and the Ashwoods first-to-market, interior permanent magnet motor. How these products are integrated, i.e. — incorporating a brake solution — represents a market-changing product. Using interior permanent magnet (IPM) technology in the motor design means the motor can be up to 70% lighter, 70% smaller and 20% more efficient than traditional motors used in off-highway traction applications.

## Introduction

Planetary gearboxes are widely used in material handling and off-highway applications. Many of these applications incorporate hydraulic motors into the planetary gearbox, but the solution discussed in this paper utilizes an electric motor for the same tasks. The gearbox used is a planetary drive manufactured by Oerlikon Fairfield under the Torque Hub name. The electric motor is an interior permanent magnet electric motor manufactured by Ashwoods Electric Motors.

The paper will outline the solution proposed by Oerlikon Fairfield and Ashwoods Electric Motors, and discuss integration of the components. Comparisons are made with the existing electric/hydraulic motor technologies typically used to drive planetary gearboxes. Alongside the performance of the solution, the testing and validation plan is also discussed.

Applications suited to the proposed solution are identified and discussed, demonstrating the feasibility of utilizing this solution within the application.

The performance of the current configuration of the planetary gearbox and electric motor is outlined in Table 1, and future models are discussed in the paper.

Table 1 48V performance	
The values below are for a 48V system with a Single Core IPM motor and a 96.15:1 Ratio	
Weight	76kg
Size (Dia x Length)	293 x 408 mm
Max Output Torque	3846 Nm
Max Braking Torque	4807.5 Nm
Max Power	9kW
Max Output Speed	62RPM
Regeneration	Full regeneration capability
IP Rating	Designed to IP65
Braking	Electric parking/emergency brake

## Interior Permanent Magnet Motor Technology

An IPM motor has the capability of combining both reluctance and permanent magnet motor technology. Permanent magnet motors are well known for their high torque density, achieved largely due to the high airgap flux density produced by rare earth magnets. A reluctance motor is able to produce torque without the use of magnets. Combining the two technologies produces an interior permanent magnet motor that



Figure 1 Ashwoods and Fairfield solution.

provides a similar torque density to an equivalent permanent magnet motor, but with up to 70% less magnet material. This can have a dramatic effect on motor cost; Figure 2 is a simple image displaying the fundamental attributes of an IPM motor.

The results produced by the characteristics mentioned above mean that an IPM motor can be up to a third of the size and weight of an induction or brushed DC motor, while staying cost-neutral or cheaper for a given power rating. It can also have performance benefits such as a high efficiency that accompanies permanent magnet motors. Yes, many IPM motor manufacturers still charge a large premium for their products, but these motors are usually highly optimized with exceptionally good performance results. Ashwoods has scaled their IPM motors from the high-performance models used in many automotive applications and targeted the cost-competitive off-highway and material handling markets with them. This approach has given a motor that is cost-competitive with traditional motor technology while offering all the benefits of permanent magnet technology.

In many applications a motor's location means it is unsprung mass and exposed to harsh vibrations; this can cause insulation failures within the motor. The Ashwoods IPM motor incorporates encapsulated windings and stator to protect

the motor against vibration fatigue. It also means the windings are not exposed to environmental conditions.

The identity of an IPM motor means the magnets are embedded within the rotor design. This eliminates risk of a magnet separating from the rotor and causing failure; it also allows the rotor to rotate at higher speeds. In addition to the windings, the magnets can be completely encapsulated, thus protecting them from environmental and vibration fatigue.

Typically, an IPM motor is low in volume and lightweight. This means the motor core does not provide a large heat-sink to distribute the losses created within the machine. Thus an intelligent cooling/air circulating design is required to provide the motor with high, continuous power. This is something Ashwoods has developed and, as a result, has produced a motor that can produce up to 70% of its peak power as an S1-rated (continuous) power.

### Oerlikon Fairfield Planetary Gearbox

Oerlikon Fairfield has been making planetary gear drives under the Torque Hub name since the product line was purchased in 1972. Until the mid-1990s, most planetary gear drives with parking brakes used bolt-on brakes versus a fully integrated brake design. As gearboxes and hydraulic motors started to become more integrated into steering applications, the requirement for shorter gear packages became prevalent. Fairfield started integrating multi-disc spring-applied, hydraulically released parking brakes into the spindle of existing gearbox designs. This resulted in the main bearings being larger in diameter, permitting the length of the brake to be incorporated in the main bearings of the gearbox and thus shortening the overall length of the package. Today, this is still the primary means of integrating a parking brake into a planetary drive for hydraulic drives.

With the current trend of electrification of vehicles, the next iteration of gearbox designs has emerged. As the motors shift in applications from hydraulic to electric, the requirement for the brake has changed accordingly; the brake is now integrated closer to the motor, as opposed to the gearbox, meaning the hydraulic ports in the gearbox are no longer required. In addition, to reduce electric motor size and cost, the optimum planetary gearbox ratio has increased, making triple-planetaries a better option. In working with Ashwoods, Fairfield has taken a standard high-volume, double planetary gearbox with an integrated hydraulic brake and replaced the hydraulic brake with a small planetary inside the former brake cavity. Standard triple-planetaries in this product line add an additional 1.48" (37.6 mm) to the overall length. With this new design the extra length is not required while still allowing an overall ratio between 67.98:1 and 130.04:1. Figure 3 shows a section of the gearbox with the hydraulic motor attached. The area highlighted

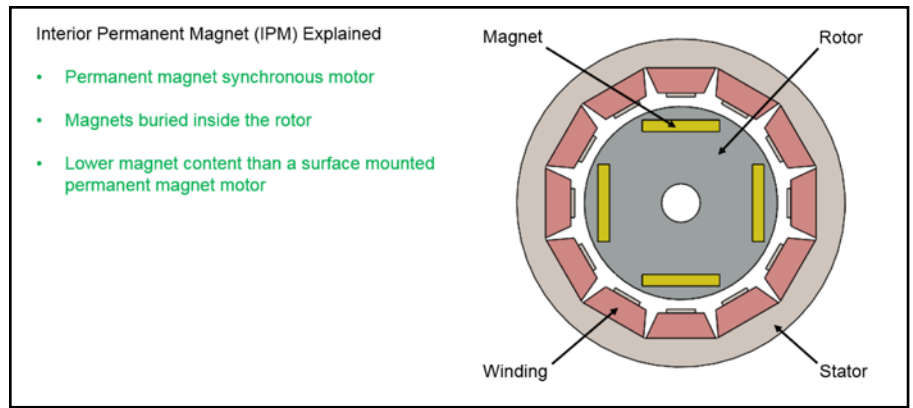

Figure 2 Interior permanent magnet explanation.

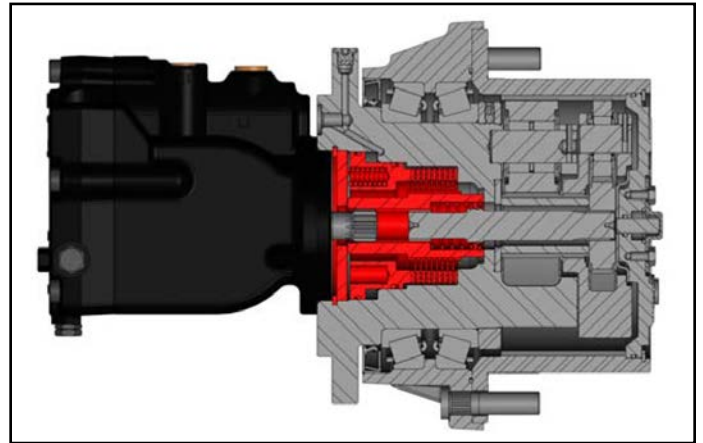

Figure 3 Two-stage gearbox with hydraulic motor.

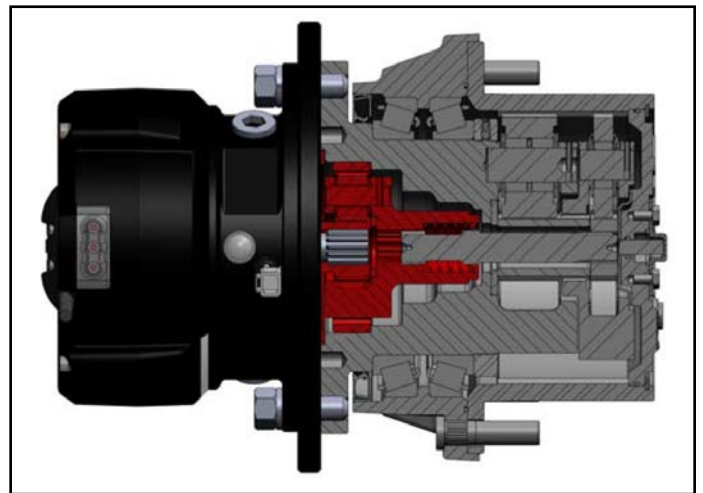

Figure 4 Three-stage gearbox with IPM electric motor.

in red is the integrated hydraulic brake. Figure 4 shows the planetary gearbox with the Ashwoods IPM motor attached. The area highlighted in red is the third planetary stage.

The gearbox technology itself is a proven design in the industry; a radial lip seal is standard as are tapered roller bearings for the main bearings. A boot (V-ring) style seal is op-

Table 2 Motor technology comparison

Motor	Size	Weight	Peak Efficiency	Peak Power	S1 Power
Interior Permanent Magnet	207 × 99 mm	7kg	94%	9kW	7kW
Surface Mounted Permanent Magnet	273 × 125 mm	15kg	91%	10kW	3kW
Induction	170 × 225 mm	21kg	86%	10kW	3kW

overall ratio between 67.98:1 and 130.04:1. Figure 3 shows a section of the gearbox with the hydraulic motor attached. The area highlighted

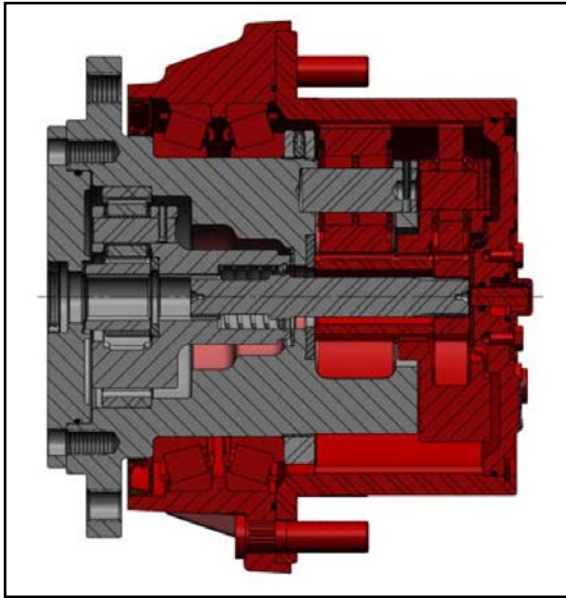

Figure 5 Rotating parts identified during mechanical disengagement of the drive (towing).

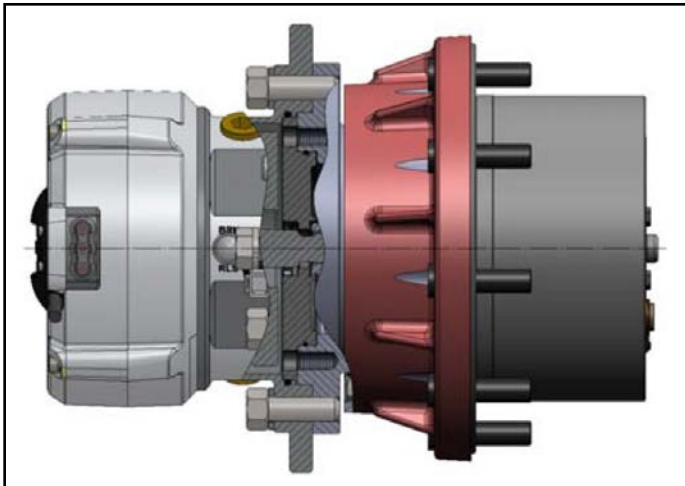

Figure 6 System integration.

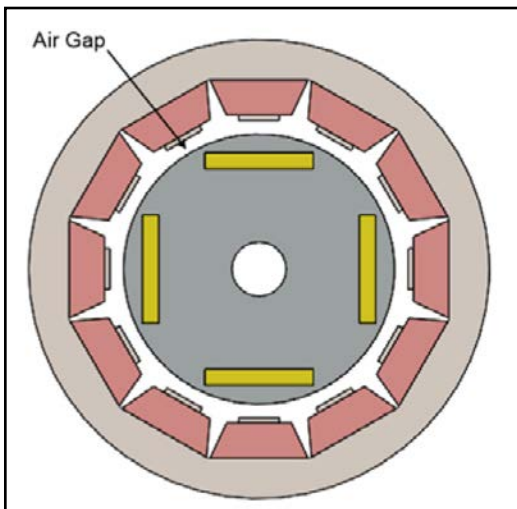

Figure 7 Mechanical air gap.

tional, depending on the environment the gearbox will be used in. An adapter plate on the spindle side of the motor will allow the gearbox to be adapted to the Ashwoods motor, while providing an additional radial lip seal to segregate gearbox oil from the electric motor.

Most Fairfield planetary drives also contain a manual disengage feature. This allows the end user to disengage the planetary from the motor so the machine can be towed. Normally, all three stages of the gearbox would be rotating under towing conditions, generating high turning losses and heat when pulled for extended periods. With the small planetary inside the spindle of this design, it is now engaged to the motor so only the last two stages will rotate under towing conditions, subsequently reducing gearbox drag, heat and noise. This also eliminates unloaded cycles on the high-speed planetary. Figure 5 shows the parts that will rotate highlighted in red.

### Integration

The integration of the planetary and motor was accomplished through the use of mounting adapters. The first, mounted to the gearbox, is a modification of the adapter used on the standard Fairfield planetary, modified to accommodate a lip seal to isolate the electric motor from the gearbox oil. The second adapter mates the motor to the gearbox, which adapts the standard motor to the standard gearbox. Slight variations in this adapter would allow the motor/gearbox to be adapted to multiple frame and hole configurations. The adapter also serves as the mounting point for the electric brake. This allows the electrical components to remain together while allowing the mechanical connection between the gearbox and motor. It provides the primary bearing support for the motor shaft — the last component of the integration — as it serves as the shaft for the motor rotor, brake reaction and integration into the gearbox coupling.

The way in which the motor, brake and gearbox are integrated enables both the motor and brake to be contained within an IP65 enclosure. It also removes one of the bearings that would typically be required to support the motor and brake.

The Ashwoods IPM motor has been designed to enable it to be assembled as a ‘cartridge’. This means the working parts of the motor can easily be integrated into another component’s housing, such as an axle, pump or gearbox.

The mechanical air gap inside a radial flux motor is a factor that drives the way in which the motor can be integrated, and can complicate things such as housings and mechanical assembly. This is something that has been identified by Ashwoods and the solution offered means the motor can share a common housing and shaft without increasing the manufacturing complexity or cost. Figure 7 identifies the air gap within a radial flux motor.

### Applications

**Aerial work platform application.** Up to now, current solutions used in production of aerial work platform machines (AWP) still utilize large, heavy and inefficient brushed DC or induction motors incorporated with planetary gearboxes. Some of the main issues for the machine manufacturers are limited vehicle range, limited space around the motor/drive-



train, and motor durability. Figure 8 shows a typical AWP platform layout using induction motors. Figure 9 shows the space saving that can be achieved using the Ashwoods IPM motor.

The solution presented by Ashwoods and Oerlikon will use a planetary drive (Torque Hub) with an integrated electric motor (IPM motor), while also housing a brake (parking brake/emergency brake) integrated into the complete package. This solution will open up packaging space on the vehicle while increasing vehicle range due to the efficiency performance of the motor.

### Other Potential Applications

Despite the solution discussed in this paper being developed for aerial work platform applications, it is also suited to many alternative applications — some of which are outlined in this paper.

**Mini excavator.** Traditionally, mini excavators utilize diesel engines producing up to 50 kW of power. The engine powers the machine's hydraulics that provides the traction, cab rotation and digging functions of the machine. Due to increasing emissions legislation and the requirement for the machine to operate in zero-emission zones such as enclosed construction sites, factory spaces and built-up environments or indoor demolition applications, companies are looking at diesel-electric hybrid alternatives. This enables the manufacturer to downsize the diesel engine to power a generator while adding electric motors to operate the machine.

It has been identified that mini excavators with an engine power of 20kW or similar will require around 7,000Nm of traction torque at the tracks. This power and torque requirement fits inside the scope of the solution proposed by Ashwoods and Fairfield, enabling the hydraulic motors to be replaced with the Ashwoods IPM motor integrated to the Fairfield planetary gearbox. This solution will be IP65-rated, meaning it can be located inside the machine tracks and protected from contamination.

**Forklift truck.** Electric traction drives are already widely used in forklift trucks. A typical layout for this is shown (Fig. 10). A large majority of these applications utilize induction or brushed DC motors, thus limiting packaging space. Alternative solutions are also used, such as incorporating a common axle across the front of the truck. But this presents the same problem that limits packaging space. Further limitations are passed onto the packaging of the hydraulics, causing the need for longer hoses that ultimately have an effect on machine efficiency. The output characteristics of the solution proposed in this paper meet the requirements of many forklift applications. Figure 10 shows a forklift truck with two induction motors packaged into the front wheels. Figure 11 shows a concept using the solution discussed in this paper and the space saving that can be achieved.

Using this integrated solution will enable manufacturers to gain system efficiency — not only due to the motor technology used, but also due to improvements to the cable layout of the hydraulic system — improving the overall system efficiency.

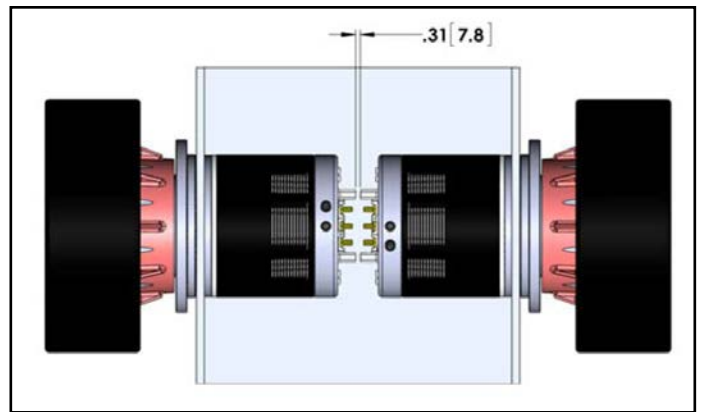

Figure 8 Induction motor packaging.

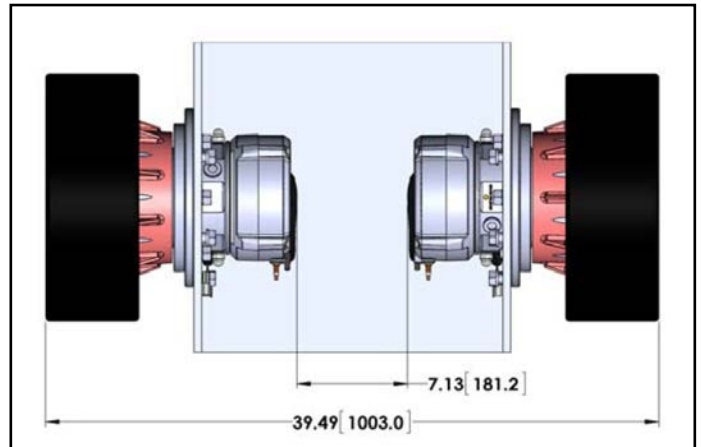

Figure 9 IPM motor packaging.



Figure 10 Forklift truck (<http://skembedjis.com/product/clark-gex/>, n.d.).



Figure 11 Concept forklift drive.

**Further Applications**

Other typical applications include, but are not limited to, commercial turf equipment, ground support equipment, light construction and industrial equipment. The benefits of using this integrated solution:

- Improved efficiency and performance without extra cost
- Extremely compact length
- Increased vehicle range with lighter vehicles
- Reducing customer application machine weight
- Easy and quick installation of the package
- Easy handling (in terms of cost and assembly on the vehicle itself)
- Bringing new innovation to replace old technology

A further benefit of using electric technology in applications that currently only utilize IC engines is related to testing and validation. Having the electronics associated with electric drives in a vehicle/application provides further options in regards to data validation. It also means fault reporting and diagnostics can be done remotely.

The motor and gearbox combination discussed in this paper is scalable and applicable to various applications. Both Ashwoods and Oerlikon Fairfield are working to extend the range of models available, some of which are identified in Table 3.

Table 3 Motor range				
Motor	Frame Size	Voltage	Power	Gearbox
IPM-2-03-25	207 x 99mm	48-80V	9-12kW	7000 Series
IPM-2-06-12	207 x 140mm	48-80V	18-24kW	W6C
IPM-2-06-25	207 x 140mm	300-400V	25-37kW	18000 Series
IPM-3-03-25	260 x 99mm	600-700V	40-50kW	N/A

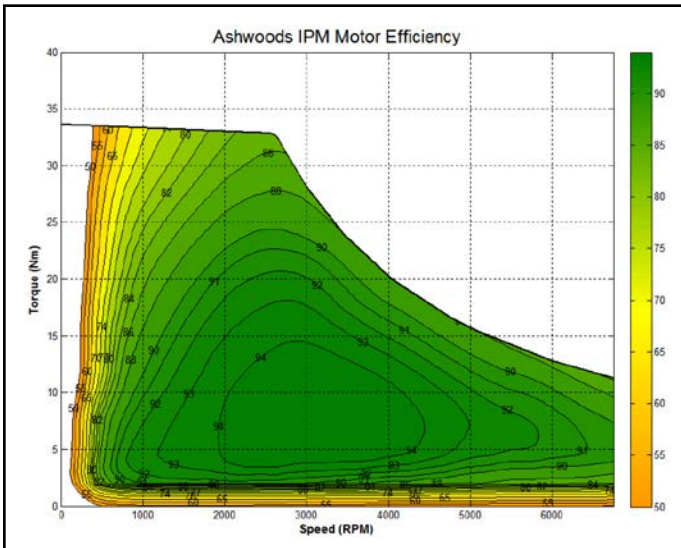

Figure 12 Efficiency map interior permanent magnet motor.

**Testing and Validation**

A major benefit of using IPM technology is the efficiency properties of the motor. Ashwoods has conducted extensive testing on their motors to optimize their efficiency properties. Figure 12 shows the efficiency map obtained from the motor identified in this paper. Comparison tests that have been done with a market-leading induction motor and the Ashwoods IPM design have shown a 20% increase in efficiency.

As stated, the thermal performance of an IPM motor can be a drawback due to its limited mass. For this reason Ashwoods has completed thermal testing on their IPM motors to represent different application drive cycles. The results shown in Table 4 are from a comparison test made with a best-in-class induction motor. The test represented a 3.5-hour transient cycle with dynamic loads showing a typical off-highway drive cycle for an application that would utilize the IPM motor. The results show the Ashwoods motor temperature initially rising at a greater rate than the induction motor, which can be attributed to the limited mass available on the IPM motor for heat distribution. But as the test continues the temperature

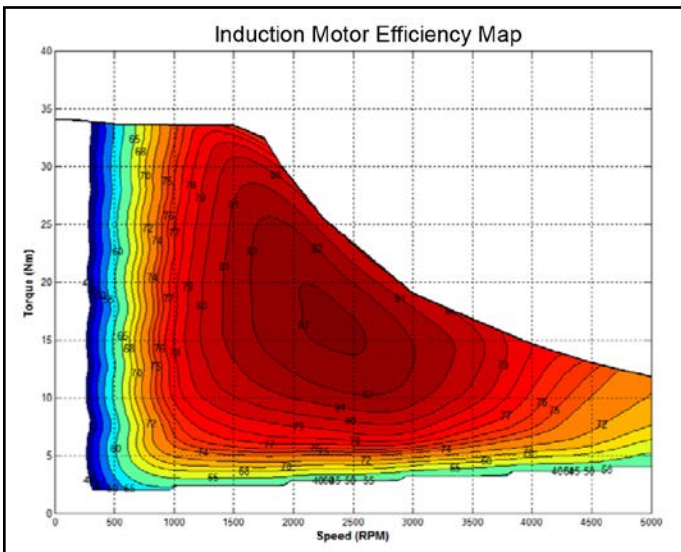

Figure 13 Efficiency map induction motor.

Table 4 Thermal performance					
Motor	Start Temp (°C)	Temp after 10 mins (°C)	Temp after 30 mins (°C)	Temp after 60 mins (°C)	Temp after 200 mins (°C)
Ashwoods IPM	20	46	54	60	60
Induction	20	39	58	81	110

of the IPM motor equalizes and the induction motor temperature rises to 110°C without equalizing. This is largely due to the cooling design inside the IPM motor and its capability to reduce its temperature during the “off-load” periods of the duty cycle. Ashwoods plans to complete further testing with varying duty cycles to validate the IPM motors’ thermal performance.

Further validation of the motor/brake/gearbox assembly has been completed at both Ashwoods and Oerlikon Fairfield. Two duty cycles have been applied to the assembly at Oerlikon to test the system’s competency and durability. The first is a high-torque/high-speed duty cycle completed over 1,000 hours. The second duty cycle is low-speed and low-torque, but completed over 50,000 hours. The results from these tests have contributed to the system validation. Figure 14 shows one of the rigs used to carry out the durability testing. In addition to the validation work being conducted at Ashwoods and Oerlikon Fairfield, the motor/gearbox combination will be installed and tested in an application.

A common failure mode for electric motors is an insulation breakdown in the windings due to over-voltage or fatigue. As mentioned in the (Interior Permanent Magnet Motor Technology section) the Ashwoods IPM motor incorporates encapsulated windings to reduce the risk of this failure occurring. To help validate the motor’s durability, vibration testing has been conducted on the motor following IEC 60068-2-24.

## Conclusion

The solution proposed by Oerlikon Fairfield and Ashwoods Electric Motors offers an alternative to the current electric traction solutions widely used in industrial and material handling vehicles. Advantages such as space saving, efficiency increase, and reduced packaging constraints complement the solution.

Validation of the unit has been discussed and the concerns addressed. Application testing is now the next step for the unit and is scheduled to be completed in 2016. The performance of the proposed current motor frame size and gearbox has been discussed and potential applications for the solution, such as aerial work platforms and forklift trucks, have been identified. In conjunction with market research, the future models discussed will be developed and the associated applications targeted. **PTE**

## References

1. <http://skembedjis.com/product/clark-gex/>. (n.d.). Retrieved from [skembedjis.com](http://skembedjis.com).
2. <http://skembedjis.com/wp-content/uploads/2014/02/clark-forklifts-gex-drive-axle.jpg>.

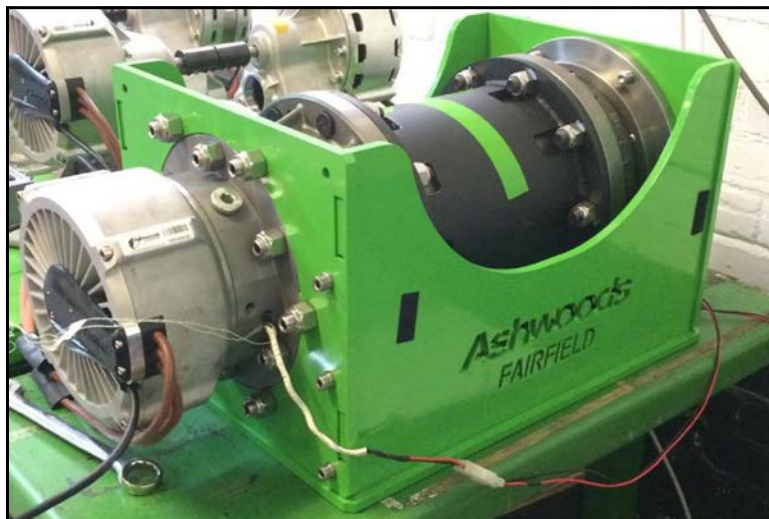

Figure 14 Durability testing.

**James Winchester** has since 2013 served as product manager at Ashwoods Electric Motors, responsible for co-ordinating development projects, identifying new market opportunities, forming strategic alliances and evaluating new technologies. Winchester holds a first class honors degree in motorsport engineering from Oxford Brookes University.



**Andrea Favale** is a product torque hub application and project engineer/off-highway for Oerlikon Graziano. He holds a degree in mechanics from Istituto Tecnico Industriale “A.Avogadro” located in Torino, Italy. He also received specialist training for CATIA 5 at Istituto Camerana Torino, specialist training for AutoCAD 14 at the Arte e Mestieri School and completed a basic course in German at the Academy International School. He began his professional career in 1998 as resident redactor of IVECO Torino, editing booklets for use and service maintenance for truck and bus vehicles. In 2000 he was employed in the R&D technical office of Technod s.r.l. as a designer for high-pressure fittings and manager of parts requirements for various customers. Since then he has served Oerlikon Graziano as R&D (designer) for bus axle/golf car application, including three months experience in the U.S. for training in planetary gears/gearboxes. In his current position Favale performance calculations relative to machine requirements for planetary drive products, including managing dedicated projects for tractor-type applications and technical support during the prototype phase; failure evaluation relative to planetary drives in the field; definition of the validation plan for the gearboxes in accordance with customer requirements; and managing repairs of broken gearboxes in the shop, ensuring delivery time and requested quality.



**Scott Martin** earned a B.S. in mechanical engineering technology at Purdue University in 1996. That same year he joined Fairfield Manufacturing/Oerlikon Fairfield as a project engineer. From 2000 to 2003 he served as a design engineer and from 2003 until 2012 as senior advanced product engineer. He also in 2012 worked as manager, drive products engineering, before assuming his current position.

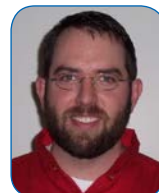

# Defining and Predicting Housing Strength for Mounted Bearings

## Design Considerations, Research and Testing Methods

The Timken Company

Design engineers across industries rely on pillow block bearings for a variety of tough and unconventional applications. Having access to data that backs housing strength performance claims is an integral part of choosing the right bearing to keep operations running optimally.

What design considerations must be made when the application demands a pillow block installation on a non-horizontal orientation? What happens when bearing load is not applied through the base of the unit? Timken answers these questions with physical testing, advanced modeling and real-world experience to facilitate the selection of pillow block bearings for specific applications.

### Why Strength Matters

The roller bearing is an essential component of countless industrial applications around the world. The reliability and repeatability of the processes where differing types of roller bearings provide functionality is important.

For most industrial operations, designers seek to maximize uptime with the selection of components that offer extended service life. In most applications where rolling-element bearings are applied, bearing static and dynamic load capacities are crucial parameters:

**Static load rating:** The maximum load a bearing can withstand before permanent damage to the raceways or rolling elements; indicates a load being applied in a constant, unchanging direction under non-rotating conditions.

**Dynamic load rating:** The radial load under which a population of bearings will achieve an L10 of one million revolutions. The load value is used to estimate bearing life based on the actual applied loads and speeds.

For pillow block (also known as plummer block, mounted bearing or housed unit) applications, the strength rating of the housing itself is a critically important performance attribute—and is why Timken performed an evaluation of housing strength and permissible load across its roller housed unit product line.:

**Solid block housings:** One-piece housings that are factory assembled, pregreased and sealed, offering simple installation direct from shelf to shaft.

**Split block housings:** Two-piece housings that are split in the middle with bolts fixing the two halves. These allow for simpler installation, and replacement of the bearings and seals without removal of the housings.

Industrial operators rely on these specialty bearings and housings for supporting shafts, gears and other rotating or oscillating components in a variety of unconventional loading orientations. Also, they often necessitate special design

considerations. For instance: What changes in design must be made when the application requires a pillow block to be installed upside down? What if the bearing load is not applied through the base?

The equipment designer relies on housing static load carrying guidance to make the appropriate selection of pillow block bearing for a given application. Thus, it's critical that these decision makers have access to housing strength information to optimize the effectiveness of equipment.

### The Need for Reliable Housing Strength Data

The demands of today's operations require bearings to work harder and longer. This means the housing must work harder, too.

Applications that generate more than one loading orientation on bearings require housings that can bear the same loads, hence the need for consistent housing strength data when designing equipment. In these types of applications, housings handle extreme forces in varying directions and allow the bearing to be mounted in positions where the load may not be applied directly through the base.

These orientations are most common in large conveyor systems and in extreme applications like industrial crushing machines or hammer mills.

Spherical roller bearings are commonly used in general industrial applications, providing dependable performance and capacity in supporting radial loads with limited axial loading.

A common question when seeking replacement mounted bearings is: What kind of load can be applied to my bearing? Answering this question is critical to selecting an appropriate bearing for the application. The geometries of mounted roller bearing housings can be complex and varied in shape, based on the size and type of bearings they support, making it complicated to estimate housing strength.

The Timken testing methodology for generating housing strength data combines advanced modeling techniques and experimental testing, all backed by real-world experience for the purpose of providing answers for customers.

### Housing Strength Testing Methodology

Loads can be applied to pillow block bearings in virtually limitless ways. Testing every housing to failure in every loading orientation is impractical, requiring a consistent modeling technique to maximize available usable data.

Timken developed a method of generating breaking strength data based on laboratory testing, advanced modeling calculations and the company's history in the metallurgi-

cal engineering field. Finite element analysis (FEA) is combined with experimental testing to create calibrated models that calculate the limiting static strength of the bearing housing. Housing strength design rules were then established and appropriate strength values published.

**Modeling/Finite Element Analysis (FEA)** FEA is deployed primarily to account for the diversity in mounted bearing housing shapes and complexities. For housing strength, FEA is desirable over simplified analytical expressions' limits in accounting for complex shapes. FEA can account for the interaction between complex housing geometry and non-linear material properties when calculating stress and strain.

Three-dimensional solid models of housings are prepared as a first step for incorporation into the FEA model. Based on the loading and geometry symmetry, a half model was created to reduce the size of the model and the subsequent solution time. These models were first solved to get a rough estimate of the breaking strength of the test parts to estimate experimental tooling requirements. The models were later refined to include failure criteria validated through experimental results. (Fig. 5)

Cast iron is commonly used for mounted bearing units, desirable for its relative structural rigidity, strength under compression and corrosion resistance. However, some applications require very high impact loads or non-horizontal mounting, where cast iron does not provide adequate strength. Cast steel offers a strong alternative.

It has approximately twice the yield strength as comparable cast iron and offers greater breakage resistance in tougher applications. Ductile iron also far exceeds cast iron in strength and can be advantageous for certain housing geometries.

Through FEA modeling, Timken is able to calculate and define accurate fracture strain and stress values. Breaking strength for cast steel housings is estimated with a non-linear elastic-plastic analysis with an isotropic hardening model. Based on the housing's material properties, ductile damage data is entered into the FEA models to check the maximum strain of each element. As the housing load is increased, the material hardens while elements elongate and exceed critical strain thresholds. The load on the housing reaches a maximum, followed by ductile fracture.

Typical strain patterns are illustrated in Figures 2 and 3. Simulated modeling that follows an established method, as outlined above, allows Timken to predict housing strengths, enabling the customer to create a more reliable and dependable design.

Modeling is only part of the process. Testing is also used to verify the modeling assumptions and provide better and more realistic model parameters.

### Physical Testing

FEA simulation assumptions were based on findings for housings loaded to the point of fracture. To determine these figures, Timken housings of different sizes were selected and loaded in a hydraulic press outfitted with specialized universal tooling then tested at a range of loads.

The universal tooling used for these experiments is able to break housings in 180-, 150- and 90-degree loading directions based on differing setup configurations, reflective of the

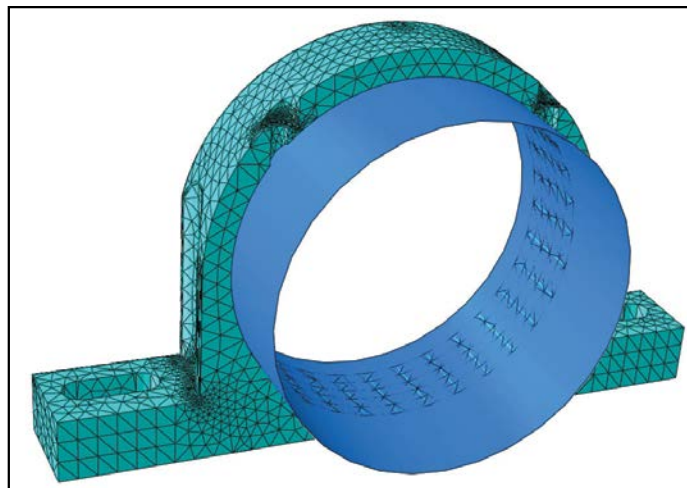

Figure 1 In this example, the material is defined as AISI 1035 cast steel, with tensile test data gathered from different foundries to improve data relevancy.

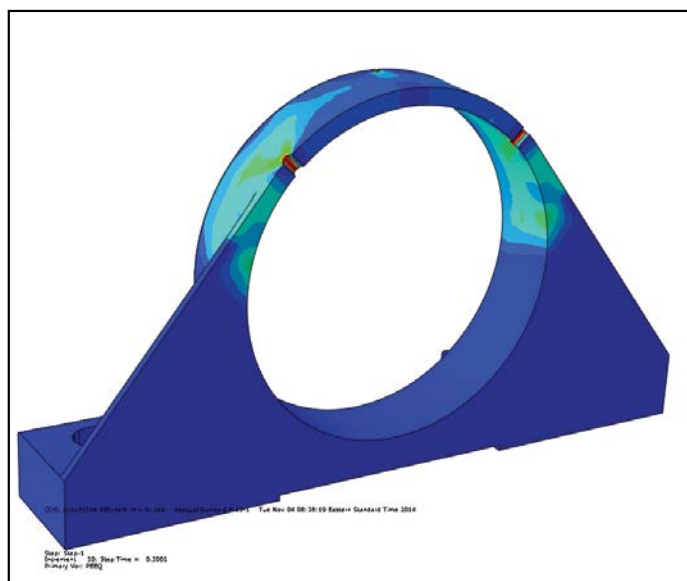

Figure 2 Stress is concentrated near lubrication holes in this housing.

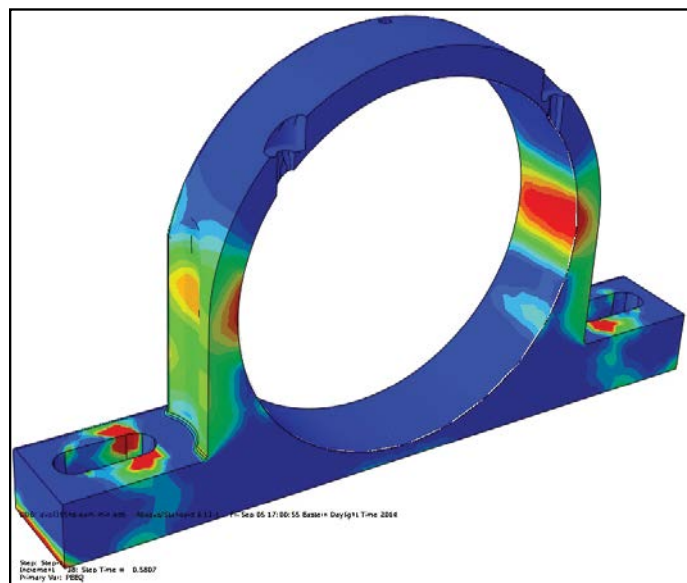

Figure 3 Strain contour plot.

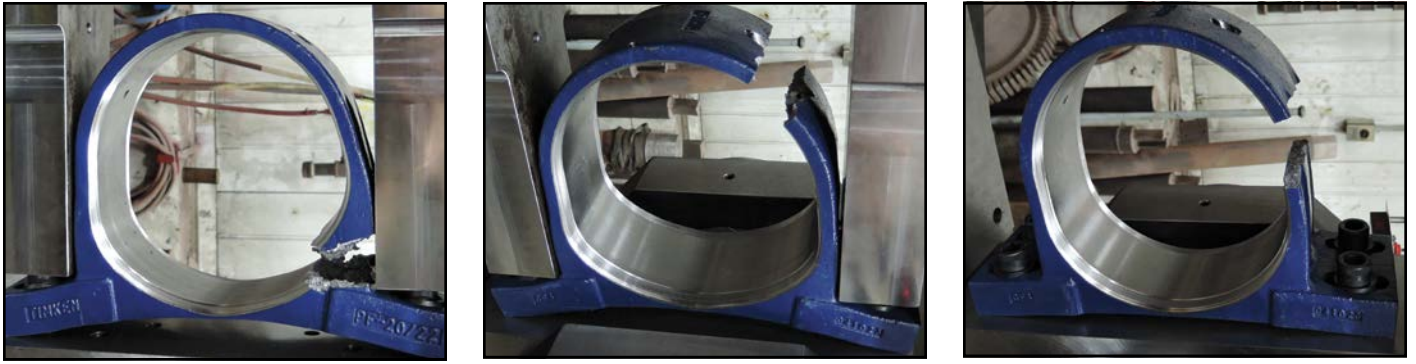

Figure 4 Fracture of split housings.

unconventional angles in which pillow blocks are installed in the real world. Since the estimated load necessary for housing fracture in these simulations could exceed the bearing static limit, no bearings were used in this exercise. Instead, they were replaced with round bars. Various styles of solid block housings and split block housings were physically tested.

Each test was performed using properly controlled loading cycles. Hydraulic fluid was slowly metered into the load piston using a control valve. A computer recorded the values of the load cell throughout the test so the maximum loads could be determined.

Multiple replicates were tested in each of the loading directions. The results of the test indicated variability between the replicates in load magnitude as well as breaking location. For example, a four bolt housing had three different failure locations when loaded in the 180-degree direction. The attachment bolts through the base flange had to be supported in each test to prevent bolt breaking and force a housing break. This was necessary even when using Grade 9 quality bolts.

The housing break failures, as seen in Figure 6, were ductile in nature, as demonstrated by the visible deformation in the housing before fracture occurred. These results were consistent with the expectations for cast steel material and assumptions based upon FEA findings. Large plastic deformation was seen at the bolt attachment area on the flanges, though no ultimate fractures occurred there. Breaking load, displacement and break location data were collected from each test.

The methodology for analyzing and testing split housings was similar to that of solid housings. The testing showed that the gray cast iron housings had a more brittle failure mode with little deformation before fracture. Breaking loads were lower than the cast steel due to the material strength difference. The ductile iron housings had larger strains than the gray iron at fracture, but not as great as the cast steel parts. (See Fig. 6.)

In the FEA, the gray cast iron housing failure criteria were defined using an extended fracture mechanics model. In comparison, the ductile iron housings used the same failure model as the solid block housings, but with a smaller fracture strain definition. The split housings also introduced another failure mode, which was bolt fracture on some of the housings. To account for this, FEA models were enhanced to include bolt ductile damage failure criteria. (See Fig. 5.)

## Housing Strength Test Results

The Timken methodology for determining housing breaking strength can help equipment designers and end users make informed decisions on the advantages and benefits of each of Timken's housed units. Through this rigorous testing process, Timken established not just the strength of its materials, but also the unique applications in which its portfolio of mounted bearings and housings will best perform, backing housing strength estimates with conclusive data.

Failure modes may vary based on casting geometry, casting material, and cap bolt size and grade. Split housings enable a simpler assembly and can help reduce overall installation cost, but do not maintain the same overall strength of comparable single-piece, solid block housings. Solid cast steel housing strength values generally exceed the bearing capacity regardless of load direction. Using a conservative approach, published housing strength values for solid block housed units were established using minimum material properties.

Gray cast iron generally has a smaller load-carrying capacity at varying orientations than ductile cast iron. While gray cast iron can be a more cost-effective material than ductile iron, it may not be the appropriate choice for more demanding applications in non-horizontal load bearing applications.

Easy-to-use safe load guidelines for Timken split housings, where load is not applied directly into the base or if the base

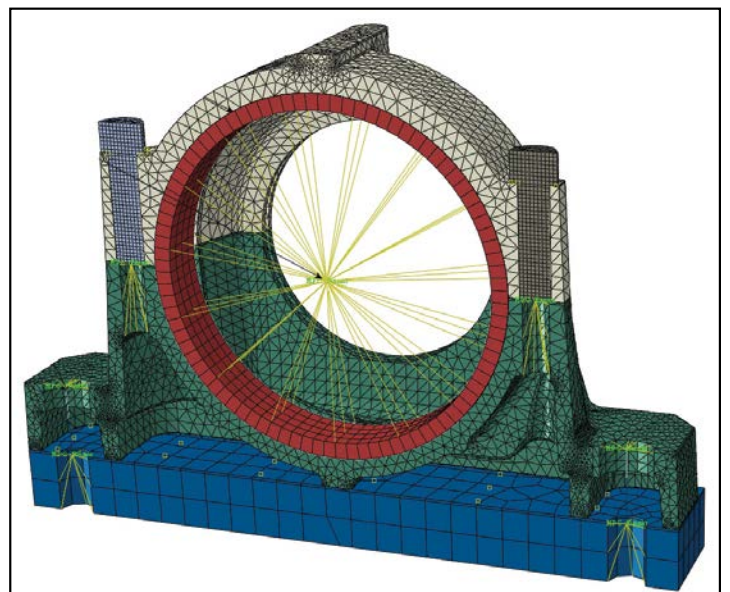

Figure 5 FEA of split housing.

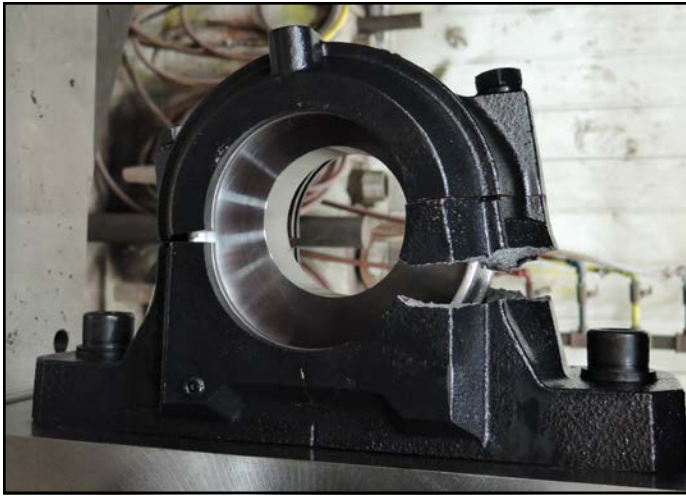

Figure 6 Fracture of split housings.

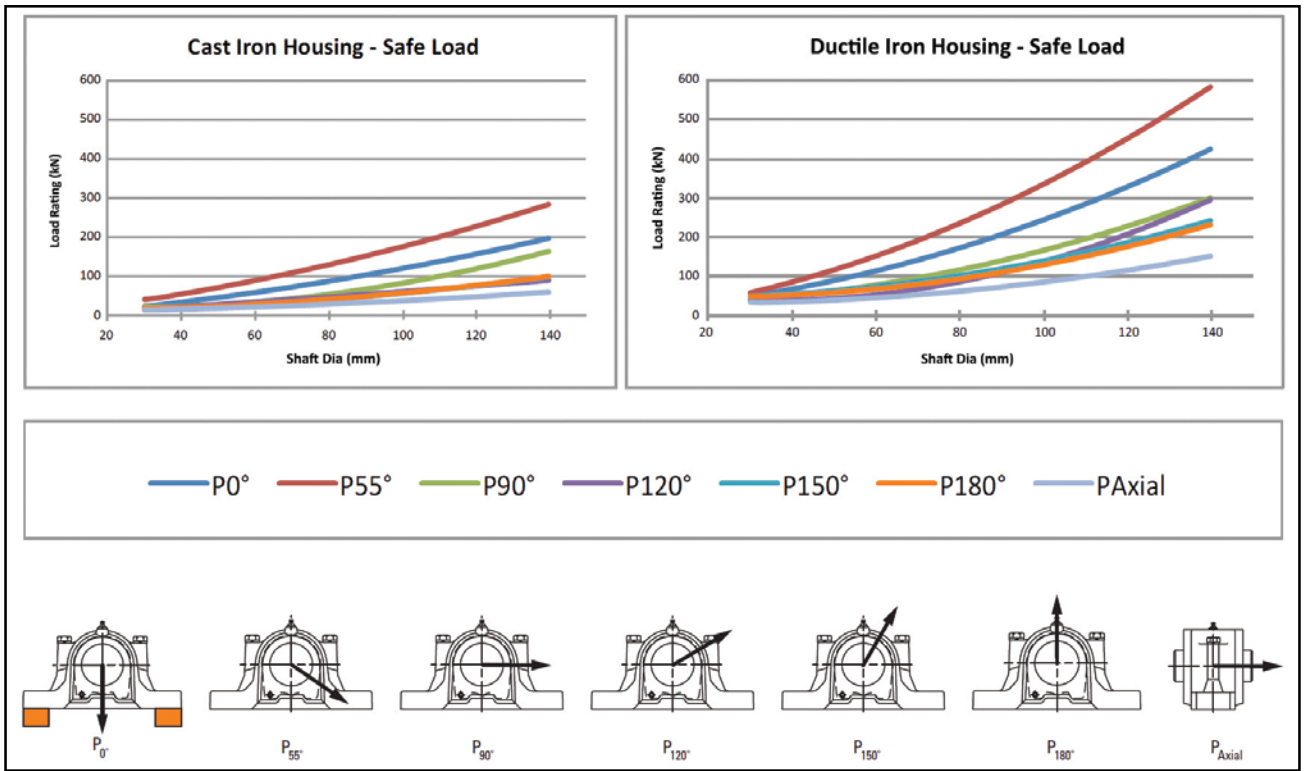

Figure 7 Comparison of housing safe loads for both cast iron and ductile iron relative to shaft size and angle of the applied load.

is unsupported (P0) have been developed. The safe load is the maximum suggested load to be applied to the housing depending on the direction of the load. The safe load guidelines for split housings account for the breaking strength of the housing and the breaking strength of the cap bolts. A commonly accepted safety factor of five is used for the breaking strength of the split housing material, and a safety factor of three is used for the cap bolt breaking strength. Additional safety factors may be applied by the user for safety-critical applications. The published safe load values assume the housing has been properly secured to the base structure and proper torque has been applied to the cap bolts.

Figure 7 shows a comparison of housing safe loads for both cast iron and ductile iron relative to shaft size and angle of the applied load. This shows the importance of housing design

and material selection in selecting the proper housing for a given application.

By using FEA results calibrated with experimental testing, Timken has created a methodology to predict housing strength without testing each unit.

Through this combination of advanced modeling and real-world experience, Timken is able to provide estimated housing strength of its mounted bearing offerings. Actionable, accessible data is one more way Timken meets the increasing demands of heavy industry every day. **PTE**

**For more information:**

The Timken Company  
Phone: (877) 454-6536  
[www.timken.com](http://www.timken.com)

For Related Articles Search

bearings

at [www.powertransmission.com](http://www.powertransmission.com)

## ABB

### INDUSTRY LEADER RECEIVES NEMA AWARD

At NEMA's 90th Annual Membership Meeting in Cleveland, Ohio, **Roger Daugherty, Ph.D.** of Baldor Electric Company, a member of the ABB Group, was awarded the Kite & Key Award from NEMA, the National Electrical Manufacturers Association in the U.S. This award recognizes industry leaders whose pioneering innovations epitomize the best in codes, standards and advocacy.

Daugherty, consulting engineer in Baldor's Advanced Development Technology Group, has been passionate about motors and their standards for most of his career. Since 1984, he has served on numerous committees, subcommittees, and working groups within the NEMA Motor and Generator Section, including chairman of the Medium Machine Subcommittee and chairman of the Technical Committee as it assumed responsibility for all machine types and sizes within the NEMA scope.

"Roger's strong presence representing the electric motor industry in technical and government circles helped not only strengthen the motor industry positions but also to raise the status of NEMA as a global authority for motor issues and policies," said Daniel Delaney, current chair of the Motor and Generator Section.

Daugherty was instrumental in the establishment of efficiency standards for energy-efficient induction motors, including the passing of the landmark Energy Policy Act of 1992. He then represented the NEMA Motor and Generator Section on all subsequent DOE motor rulemakings, including the Energy Independence and Security Act of 2007, the Small Motor Rule and Test Procedures in 2010, and the Integral Horsepower Motor Rule and Test Procedures in 2014. He has been influential in the continuous revision of NEMA MG 1 Motors and Generators and other NEMA standards and guides.

In addition to his work with NEMA, Daugherty has traveled throughout the world participating in the development of IEEE, IEC, CSA, and CANENA global motor standards and has been active in the revision of IEC standards relative to application in the U.S. ([www.abb.com](http://www.abb.com))



## C&U Americas

### RECEIVES 2016 SUPPLIER QUALITY AWARD

C & U Americas, LLC, the North American subsidiary of the C&U Group, recently received a 2016 Supplier Quality Award from Hitachi Automotive Systems México S.A. de C.V. Gilberto Figueroa, Hitachi Automotive Systems Mexico, SA de, C.V. chief operation officer, sanctioned the award to C&U Americas in recognition of exceptional quality and continuous improvement.



Tom Rouse, president of C & U Americas, accepted the award along with Mike Caldwell, quality manager and Victor Lopez, regional sales manager Mexico, during Hitachi's 7th Supplier Quality Day, which was held at the Hitachi Automotive Systems México facility in Toluca, MX.

Rouse noted, "It is a particular honor to receive Hitachi's 'Supplier Quality Award' because it recognizes and reinforces one of our key positions in the marketplace. At C&U Americas, we promise our customers 'World Class Quality' and this important award from Hitachi is a testament to our commitment and ability to deliver on that promise."

Hitachi Automotive Systems Mexico, S.A. de C.V., a part of Hitachi Automotive Systems' global operations, offers a broad range of products and services for the automotive industry. The company manufactures and markets automotive components that contribute to fuel efficiency, engine, and tire performance as well as heightened driver and passenger comfort, convenience, and enjoyment. ([cubearing.com](http://cubearing.com))

## CTI

### ANNOUNCES WINNERS OF YOUNG DRIVE EXPERTS AWARD

No fewer than three candidates won the 8th CTI Young Drive Experts Award at the 15th International CTI Symposium for Automotive Transmissions, HEV and EV Drives. First place overall went to Dr. Marco Denk (research associate at Bayreuth University), second place to Harald Kraus (head of the scientific team E-Mobility and Alternative Drives) and third place to Dr. Markus Bachinger (executive engineer at AVL List GmbH, Graz).

Denk won first place with his doctorate entitled "In Situ Monitoring of IGBT Performance Semiconductor Modules using Real-Time Rectifier Temperature Readings." This involved developing a smart drive switch element for the power electronics that not only activates and deactivates the



semiconductors, but for the first time can identify its operating load and age-related performance too — and store both on an EEPROM. To enable this, Denk developed a procedure that can be implemented on an industrial scale to measure the semiconductor's rectifier temperature. The measuring procedure was successfully implemented in a hybrid automotive transmission's inverter, and is the first functional, series-production enabled solution for identifying the load status of a non-modified power module.

Kraus won second place for developing an operation strategy for plug-in hybrid electric vehicles based on previous vehicle and driver data. He presented an intelligent Energy Management Controller that can improve vehicle performance by maintaining the battery's energy level efficiently. This is claimed to yield fuel savings of up to 11.7 percent, and could also help to achieve future CO<sub>2</sub> targets: even high-performance automobiles (>200 kW) could approach 95g/CO<sub>2</sub> on average by 2020.



Due to higher version counts and the complexity of electrified drivetrains, together with rising demands in terms of shift quality, the automotive industry is focusing more strongly on model-based solutions. Until now, no generic approaches were known for releasing fixed sample steps for multiple interacting friction elements. Bachinger won third place with his approach for the generic modelling of transmission topologies with multiple coupled friction elements. In addition to general usability, the core of this approach is the release for the discontinuously occurring friction fit. The generic approach also provides the basis for a status and input disturbance monitor that is based on a single monitoring feedback matrix, despite the system's shift character. ([www.transmission-symposium.com](http://www.transmission-symposium.com))

## Rocky Mountain Technologies

### State of the Art Custom Design and Consulting Services

Where Innovation and Solutions Meet

- We Deliver Custom Motors and Drives
- We Design Your Custom Motors and Drives
- We Assist with In-House Design and Consulting
- Prototyping, Pre-Production, Product Performance
- Strategic Partners Volume Sourcing



**(406) 552-4260**

[sales@rockymountaintechnologies.com](mailto:sales@rockymountaintechnologies.com)

Rocky Mountain Technologies, P.O. Box 210, Basin, MT 59631

BEYTA GEAR SERVICE 

**PUTTING  
A LIFETIME**

**OF**

**GEAR  
DESIGN**

**EXPERIENCE**

**TO WORK FOR YOU**

- Reverse engineering
- Gearbox upgrades
- Custom gearbox design
- Specification development
- Project management
- Vendor qualification
- Design reviews
- Bid evaluations
- Tooling design
- Customized gear training
- Equipment evaluation
- Custom machine design

**Charles D. Schultz**  
**[chuck@beytagear.com](mailto:chuck@beytagear.com)**  
**[630] 209-1652**

[www.beytagear.com](http://www.beytagear.com)

## Gates Corp.

ANNOUNCES 2016 TOOLS FOR SCHOOLS/ASE INSTRUCTOR OF THE YEAR

Gates Corporation and the National Institute for Automotive Service (ASE) has announced that Dan Rowland of Hesperia, California is the 2016 Gates Tools for Schools/ASE Instructor of the Year. Rowland is an instructor at Victor Valley Com-



munity College in Victorville, California. Rowland bested thousands of ASE technicians who competed for top honors within this category. He and other educators and technicians were honored by the ASE at the annual Fall Board Meeting. The purpose of the Tools for Schools program is to provide educators with supplemental educational materials from a global leader in the Automotive Aftermarket. ([www.gates.com](http://www.gates.com))

## In-Tech

HIRES 100<sup>TH</sup> ASSOCIATE IN THE UNITED STATES

In-Tech recently announced that its center in Greer, South Carolina, just appointed its 100th associate. In 2013, the U.S. In-Tech affiliate started with just five associates. Since then, the company has grown tremendously. Initially, the business focused on the development of electronic components for the automotive industry. Step by step, In-Tech added expertise in the areas of mechanical and software engineering. Now, In-Tech accompanies numerous projects in the United States and abroad.



"We are very happy with our continuous growth and look forward to the coming projects, which will keep our 100 associates busy. Our business relies on friendly relations with all our associates. We made this our maxim when we estab-

lished the U.S. In-Tech affiliate company," said **Christoph Schönmetzler**, CEO of In-Tech Automotive Engineering.

The US domicile of In-Tech Automotive Engineering is located in downtown Greer, South Carolina. This puts the company right in the center of many automotive OEMs and their suppliers. Greer is also the direct port of call for automotive suppliers south-east of Greer. Offices in New Jersey and California complete the In-Tech network in the United States.

The 100th associate joining In-Tech in Greer represents a milestone and emphasizes both the company's employee-friendly culture and its taste for innovation. Associate Christopher Collins is a perfect fit: "I always wanted to contribute my expertise in automotive engineering at work. Therefore, I did not hesitate a moment to make my new home in a place 900 miles away and work for In-Tech."

In-Tech started in 2002 in Munich. Worldwide, more than 800 people have joined In-Tech as associates. In 2015, the company founded the affiliate enterprise In-Tech Industry and with it expanded its portfolio to Industry 4.0 solutions. Right now, In-Tech expertise and services are synonymous with smart machine parts, networked production facilities and intelligent building automation for customers in the fields of mechanical engineering, automotive engineering and the transportation industry. ([www.in-tech.com](http://www.in-tech.com))

## ITAMCO

ATTENDS WHITE HOUSE EVENT

ITAMCO attended an event at the White House hosted by the National Economic Council on Wednesday, December 21. The function was held in recognition of the progress made by ITAMCO and other U.S. manufacturers in the Manufacturing USA program. Daniel Neidig, vice president, and Joel Neidig, business development and technology manager, represented ITAMCO at the event. "It was an honor for ITAMCO to be invited by President Obama's Chief of Staff, Denis McDonough, to participate in the emerging technology event held at the White House. Enhancing our industrial competitiveness through advanced manufacturing initiatives has always been an essential principal of the company's philosophy since its early beginnings over 60 years ago. Collaborating with various departments of the government and universities is a key strength of our organization. ITAMCO looks forward to being a stakeholder in Manufacturing USA and is excited to help solve industry-relevant manufacturing challenges in the future," said Daniel Neidig. ([www.itmaco.com](http://www.itmaco.com))



## Miki Pulley

LAUNCHES 3D CAD PRODUCT DOWNLOADS ON WEBSITE

Now designers can select and configure the exact Miki coupling, brake and clutch solution for a particular application at the website below. The 3D model interface allows for an intuitive, faceted search so customers can find a solution quickly.

To select the correct product, the system designer simply enters the product type. The search will provide varying degrees of performance criteria, sizes, bore configurations, voltage, etc. Each selection made by the designer will shorten and narrow the list. Once the exact model, size and configuration is shown, it can be downloaded in most CAD formats for importing into the designers' drawing.



No more modifying a generic one-size-fits-all drawing, Miki-Pulley will give the designer the exact drawing of what is needed for correct system operation.

"Miki Pulley product downloads have proven extremely helpful to design engineers when configuring a system because of the precision detail they provide," reports Jon Davidson, Miki Pulley product specialist. "For example, when searching for the correct coupling to use in a system, Miki Pulley downloads provide exact bore and keyway sizes. This allows the system designer to import the CAD model into a full assembly drawing with complete accuracy as to the coupling's size, fit and performance capabilities. It shortens the design cycle."

The Miki Pulley 3D model interface operates with all popular browsers including Internet Explorer, Firefox and Google Chrome. The website interface will facilitate a design engineer's evaluation and navigation to a product solution. Additional site features include: PDF catalog downloads, complete product listing, examples of industries served. ([www.mikipulley-us.com](http://www.mikipulley-us.com))

## Hansford Sensors

PUBLISHES WHITE PAPER ON EARLY BEARING FAILURE DETECTION

Hansford Sensors, a manufacturer of vibration monitoring equipment, has published a new white paper that reveals how to use envelope signal processing to pinpoint bearing failure at an early stage. The new white paper is a must read for engineers looking to minimize the risk of machine damage and failure.

Vibration analysis has become a popular method for discovering wear and damage to rotating components in machinery, but sometimes the identifying signal is drowned out in all the other noise produced by a machine. Acceleration enveloping allows maintenance teams to overcome this challenge and pinpoint potentially costly problems as early as possible.



The new white paper, which is titled, "Acceleration Enveloping to Detect Bearing Damage," explores the relatively unknown acceleration enveloping technique in new depth. It explains the important role it has to play in today's manufacturing and process environments and describes how it works. It also provides an example of the process in application, helping readers to gain a better understanding of the technique in practice.

"Catching bearing defects as early as possible is essential if manufacturers are to stop them developing into more serious problems. One way of achieving this is to implement the acceleration enveloping technique," explained Chris Hansford, managing director of Hansford Sensors. "Our new white paper provides maintenance and servicing teams with all of the information they require to fully understand this technique." ([www.hansfordsensors.com](http://www.hansfordsensors.com))

# IFPE 2017

## Fluid Power, Motion Control and Power Transmission Industries Come Together in Las Vegas to Promote New Solutions

Matthew Jaster, Senior Editor

Every three years Las Vegas welcomes those involved in mobile hydraulics, water hydraulics, pneumatics, electrical and mechanical power transmission and industrial hydraulics for the International Fluid Power Exposition (IFPE).

From March 7-11, suppliers, engineers, manufacturers and service providers that represent a diverse industrial base (off-highway, construction, factory automation, power transmission, machine tools, controls, to name a few) present new advances, innovations and technologies to improve the performance of hydraulic and pneumatic systems and applications.

In addition, the show is co-located with CONEXPO/CON/AGG, the largest international gathering for the construction industry with 2,500 exhibitors and more than 2,500,000 square feet of exhibits. Here's a breakdown of some programs and exhibits featured at IFPE 2017:

### Education Opportunities

IFPE 2017 will host the fluid power industry's prestigious Energy Efficient Hydraulics and Pneumatics Conference (EEHPC) in addition to offering hands-on "college course" education on the effective use of hydraulics in mobile equipment.

"We're pleased that the EEHPC conference will be held in conjunction with IFPE to bring an added dimension of fluid power education to the show. Industry professionals will benefit from the additional knowledge-sharing and networking," said Bob Mortensen, IFPE 2017 chair and president off-highway division of HUSCO International.

The Energy Efficient Hydraulics and Pneumatics Conference (EEHPC) focuses on concepts and techniques to keep fluid power (hydraulics and pneumatics) systems operating at peak efficiency to reap significant energy savings. The conference traditionally includes a "future of fluid power" program, which at IFPE 2017 will explore robotics challenges and opportunities.

Four half-day IFPE "college-level courses" will emphasize hands-on technical knowledge on the effective use of hydraulics in mobile equipment: (1) fundamentals of hydraulic



systems; (2) hydraulic fluid properties, efficiency and contamination control; (3) hydraulic system design strategies for mobile applications; and (4) electro hydraulic, systems design and control.

IFPE focuses on the latest innovations, product advances and expert insights to fully equip engineers and others involved in the design and manufacturing process to increase efficiency, contain costs and improve the performance of their hydraulic and pneumatic systems and applications.

### World of Fluid Power Summit

The world of fluid power is getting ready to gather at IFPE 2017. This summit, hosted by the National Fluid Power Association (NFPA), will bring the world of fluid power together for information sharing and education. The World Fluid Power Summit will be held on Thursday, March 9, 2017, beginning at 12:00 noon, at the Las Vegas Convention Center, and will include lunch for all attendees. Industry and association leaders from around the globe will participate in the following agenda:

12:00 Lunch Served

12:30 Welcome, Opening Remarks (Marc Weston, Danfoss Power Solutions; Vice Chair, NFPA)

12:45 Worldwide Need and Availability of Fluid Power Certification Programs (Rance Herren, National Oilwell Varco; Immediate Past President, IFPS)

- 1:15 Standards: The Importance of Relevance, and the Need for Technical Support to Meet Market Needs (Gary Baumgardner, Chair, ISO TC 131)
- 1:45 Report from the International Fluid Power Statistics Committee (Stéphane Rakotoarivelo, Vice President, CETOP)
- 2:00 Worldwide Fluid Power Market Trends (Including China, Europe, Australia, India, the United States and more)
- 3:15 Open Q&A
- 3:30 Adjourn

AGG and IFPE each show year and 2017 will not disappoint. We're thrilled to bring such a significant technological and first-of-its-kind achievement like the 3D printed excavator to the show; it will be a platform to demonstrate how the latest innovations and applied technologies are changing the future of construction industry," said John Rozum, IFPE show director.

The excavator is a joint collaboration between the Association of Equipment Manufacturers (AEM), National Fluid Power Association (NFPA), Center for Compact and Efficient Fluid Power (CCEFP), Oak Ridge National Laboratory (ORNL) and the National Science Foundation (NSF).

The group is working with research teams from Georgia Tech and The University of Minnesota to convert the current excavator design to one that is conducive to and takes full advantage of 3D manufacturing. Graduate engineering students at Georgia Tech will be creating a boom and bucket featuring integrated hydraulics with the goal of decreasing the weight, materials cost and maintenance, while students at the University of Minnesota are designing a hydraulic oil reservoir/heat exchanger and cooling system that reduces the size and weight and increase the efficiency of the machine.

"Technology and innovation will drive change for the future of the construction industry, and we're excited that students are playing a vital role in bringing the newly designed machine to life," said Eric Lanke, chief executive officer of NFPA.

In addition to the partnerships with the Georgia Tech and the University of Minnesota, AEM, NFPA, CCEFP, ORNL and NSF are inviting undergraduate engineering students from across the country to participate in a nationwide contest to design and print a futuristic cab and a human-machine interface for the excavator. **PTE**

### Registration

Visit the IFPE website for registration information ([www.ifpe.com/exhibit/register/](http://www.ifpe.com/exhibit/register/)) or call (800) 424-5247.



The Summit is open to all interested participants, but seating will be limited, and advance registration is required. For more information, contact Eric Lanke at [elanke@nfpa.com](mailto:elanke@nfpa.com).

### 3D Excavator Display

CONEXPO-CON/AGG and IFPE 2017 are teaming up to unveil the world's first fully-functional 3D printed construction excavator and the first large-scale use of steel in 3D printing, known as additive manufacturing. The excavator, which will be on display at the joint trade shows will bring to life how technology is transforming the construction industry in line with the show's 2017 theme, "Imagine What's Next." In addition to the pre-printed excavator, show attendees will be able to view a demonstration of the 3D printing technology.

"We know our members look forward to seeing the industry's most innovative technologies at CONEXPO-CON/

### March 6–9—AeroDef Manufacturing 2017

AeroDef 2017 showcases the industry's most advanced technologies across an innovative floor plan designed to facilitate interaction and business relationships between exhibitors and buyers looking for integrated solutions. Keynote speakers and panelists come from the highest level of government and business. They come to share their vision of the potential of technology, collaboration and public policy to transform manufacturing—concepts that attendees can actually experience on the exposition floor and in conference sessions. It's the one event that brings together high-concept, integrated solutions and real-world applications. Produced by the SME, in partnership with industry OEMs, the show's mission is to foster innovation across the extended enterprise to reduce costs, expedite production times and maintain manufacturing competitiveness in the global economy. For more information, visit [aerodefevent.com](http://aerodefevent.com).

**March 7–11—IFPE 2017** Las Vegas, Nevada. IFPE returns every three years to showcase the latest innovations and expertise in the fluid power, power transmission and motion control industries. Educational opportunities provide crucial information on new fluid power, power transmission and motion control technologies to engineers and others involved in the design and manufacturing process. Co-located with CONEXPO-CON/AGG 2017, the largest international gathering place for the construction industries, attendees will have access to the latest products and innovations from over 400 exhibitors. IFPE 2017 also features product concentration areas, making it easy for visitors to locate specific products, services and exhibitors of interest. For more information, visit [www.ifpe.com](http://www.ifpe.com).

### March 21–23—AGMA 2017 Gearbox CSI

Concordville, Pennsylvania. Gain a better understanding of various types of gears and bearings. Learn about the limitation and capabilities of rolling element bearings and the gears that they support. Grasp an understanding of how to properly apply the best gear-bearing combination to any gearbox from simple to complex. Gear design engineers; management involved with design, maintenance, customer service, and sales should attend. Instructors include Ray Drago and Joseph W. Lenski, Jr. For more information, visit [www.agma.org](http://www.agma.org).

### March 22–24—PTDA Leadership Development Conference 2017

New Orleans, Louisiana. Step up your leadership game, while networking with your power transmission/motion control industry peers in an intimate and relaxed setting. Educational sessions are designed for emerging and seasoned executives who want to build executive leadership skills. Open to all employees of PTDA member companies. No other program provides the industry-specific networking so essential for success in the power transmission/motion control distribution industry. Because the Leadership Development Conference is incorporated into the Association's Spring Meetings, participants can also attend the dinner and talk on Thursday evening along with the industry's top executives who volunteer on PTDA committees and the board of directors. For more information, visit [www.ptda.org](http://www.ptda.org).

### March 22–25—The Mfg Meeting 2017

Amelia Island, Florida. Hundreds of manufacturing leaders will gather to gain a deeper understanding of the forces transforming manufacturing—from the digital factory and cybersecurity to economic and global market trends. Featuring an array of entrepreneurs, technologists, business experts, and more, MFG speakers give insight for the future of manufacturing along with inspiration to lead your organization with courage, clarity, and wisdom. Keynote speakers include tech entrepreneur Josh Linkner, current player for the Philadelphia Eagles, Jon Dorenbos and Douglas K. Woods, president of AMT. Jointly produced by the Association for Manufacturing Technology (AMT) and the National Tooling and Manufacturing Association (NTMA), this event tackles the issues that affect the entire realm of manufacturing. For more information, visit [www.themfgmeeting.com](http://www.themfgmeeting.com).

### March 30–April 1—AGMA-ABMA Annual Meeting 2017

Rancho Mirage, California. The 2017 Annual Meeting marks the start of a new century for both AGMA and ABMA and the introduction of a more robust education program. Not only has the planning committee expanded the number of presentations, but they have also offered a tremendous amount of versatility, all thanks to the AGMA and ABMA members. Business presentations include Internet of Things, Economic Forecast, Aerospace Technologies, Disruptive Technologies, Hiring Practices, Post-Election Manufacturing Outlook, and a Guide to Selling Your Company. Additionally, "Endeavor to Succeed" will feature Captain Mark Kelly, Commander of the Space Shuttle Endeavour's Final Mission. For more information, visit [www.agma.org/events/agma-abma-annual-meeting](http://www.agma.org/events/agma-abma-annual-meeting).

### April 3–6—Automate 2017

Automate 2017 will showcase the full spectrum of automation technologies and solutions, from traditional industrial applications to cutting edge new technologies. Live show demonstrations will inform the industry on the successful integration of automation, robotics and machine vision. The rest of the show features the latest automation, robotic, vision and motion control technologies and systems on display from leading global suppliers. ProMat 2017 is co-located with Automate and provides attendees access to the latest material handling and logistics equipment and technologies. For more information, visit [www.automateshow.com](http://www.automateshow.com).

### April 3–7—2017 Basic Training for Gear Manufacturers (Spring)

Oak Lawn, Illinois. Learn the fundamentals of gear manufacturing in this hands-on course. Gain an understanding of gearing and nomenclature, principles of inspection, gear manufacturing methods, and hobbing and shaping. Utilizing manual machines develop a deeper breadth of perspective and understanding of the process and physics of making a gear as well as the ability to apply this knowledge in working with CNC equipment commonly in use. This course is taught at Daley College. A shuttle bus is available each day to transport students to and from the hotel. Although the Basic Course is designed primarily for newer employees with at least six months' experience in setup or machine operation, it has proved beneficial to quality control managers, sales representatives, management, and executives. Course instructors are Dwight Smith, Allen Bird and Peter Grossi. For more information, visit [www.agma.org](http://www.agma.org).

# Hungry for More?



Everything you need if you buy gears, bearings, motors, couplings and clutches.

## Power Transmission Engineering

- Product and Industry News Updated Daily
- Directory of Mechanical Power Transmission Suppliers
- Exclusive online content in our e-mail newsletters
- Back Issues and Article Archive
- Calendar of Upcoming Events for power transmission professionals

FREE SUBSCRIPTION!

[www.powertransmission.com](http://www.powertransmission.com)

## CALL FOR PAPERS!

Are you sitting on an idea for a technical paper but wondering where to present it? Do you have one already written, sitting on your desk, gathering machine dust?

How about *Power Transmission Engineering*? We are always looking for gearing- and power transmission component-relevant technical papers for publication in the magazine and in its digital version. Having your work appear in *Power Transmission Engineering* guarantees you an audience of the most experienced and discriminating industry players. You say your work has not been peer-reviewed? Not a problem, as we are lucky—and thankful—to have on-hand some of the most experienced and brilliant minds in the industry—our technical editors. So if your work “passes muster” and is published, you’ll know you were reviewed by the best—and most demanding.

Chances are you’ll be creating the paper under the auspices of the company for whom you work or own, or for one of the various industry-relevant associations. That means they as well will bask in the reflected glory that accrues with publication in *Power Transmission Engineering*.

For publication guidelines and more information, please contact Jack McGuinn at [jmcguinn@powertransmission.com](mailto:jmcguinn@powertransmission.com).

### AGMA

Page 3  
[www.gearexpo.com](http://www.gearexpo.com)

### Automate 2017

Page 7  
[www.automateshow.com](http://www.automateshow.com)

### B&R Machine and Gear

Page 34  
[www.brgear.com](http://www.brgear.com)

### Beyta Gear Service

Page 55  
[www.beytagear.com](http://www.beytagear.com)

### Circle Gear

Page 21  
[www.circlegear.com](http://www.circlegear.com)

### Diequa Corp.

Pages 12, 35  
[www.diequa.com](http://www.diequa.com)

### Excel Gear

Page 17  
[www.excelgear.com](http://www.excelgear.com)

### Forest City Gear

Page 9  
[www.forestcitygear.com](http://www.forestcitygear.com)

### Gear Expo

Page 3  
[www.gearexpo.com](http://www.gearexpo.com)

### Martin Sprocket

Page 19  
[www.martinsprocket.com](http://www.martinsprocket.com)

### McInnes Rolled Rings

Page 10  
[www.mcinnesorledrings.com](http://www.mcinnesorledrings.com)

### Miki Pulley

Page 16  
[www.mikipulley-us.com](http://www.mikipulley-us.com)

### Napoleon Engineering Services

Page 13  
[www.nesbearings.com](http://www.nesbearings.com)

### Nordex Inc.

Pages 14, 34  
[www.nordex.com](http://www.nordex.com)

### Noria

Page 33  
[conference.reliableplant.com](http://conference.reliableplant.com)

### R+W America

Page 11  
[www.rw-america.com](http://www.rw-america.com)

### Reliable Plant

Page 33  
[conference.reliableplant.com](http://conference.reliableplant.com)

### Rocky Mountain Technologies

Page 55  
[www.rockymountaintechnologies.com](http://www.rockymountaintechnologies.com)

### Schaeffler Group

Back Outside Cover  
[www.schaeffler.us](http://www.schaeffler.us)

### SEW-Eurodrive

Inside Back Cover  
[www.seweurodrive.com](http://www.seweurodrive.com)

### SKF

Inside Front Cover  
[skf.com](http://skf.com)

### Suhner Manufacturing

Page 2  
[www.suhner.com](http://www.suhner.com)

### Turner Uni-Drive

Page 34  
[www.turnerunidrive.com](http://www.turnerunidrive.com)

### Zero-Max

Page 5  
[www.zero-max.com](http://www.zero-max.com)



# Power Transmission Engineering



**Power Transmission Engineering** is Your KEY to understanding Gears, Gear Drives, Bearings, Motors, Clutches, Couplings, Brakes, and other Power Transmission Components.

Unlock your FREE subscription by filling out this form.

## FREE SUBSCRIPTION

**1**  **YES** I want to receive/continue to receive **Power Transmission Engineering** FREE!  
 No thank you.

Name: \_\_\_\_\_ JobTitle/Position: \_\_\_\_\_  
(print)

Signature \_\_\_\_\_ Date: \_\_\_\_\_  
(required)

**2** E-mail \_\_\_\_\_  
(So we can notify you when the online edition is available)

 **SAVE a TREE!**  
 I ONLY want the digital edition (e-mail required)

**3** Please update your contact information or attach you business card here. (No Staples)

Company Name: \_\_\_\_\_  
Address: \_\_\_\_\_  
\_\_\_\_\_  
\_\_\_\_\_  
City: \_\_\_\_\_  
State/Province: \_\_\_\_\_ ZIP+4/Postal Code: \_\_\_\_\_  
Country: \_\_\_\_\_  
Telephone: \_\_\_\_\_ Fax: \_\_\_\_\_  
E-mail: \_\_\_\_\_  
Website: \_\_\_\_\_

**5** My company's principal product or service is: \_\_\_\_\_

**6** What is your primary job function responsibility? (Check one)

<input type="checkbox"/> Corporate Management (1)	<input type="checkbox"/> Quality Control (7)
<input type="checkbox"/> Plant Engineering (2)	<input type="checkbox"/> Factory Automation (8)
<input type="checkbox"/> Design Engineering (3)	<input type="checkbox"/> Maintenance (9)
<input type="checkbox"/> Marketing & Sales (4)	<input type="checkbox"/> Other (10)
<input type="checkbox"/> Manufacturing Engineering (5)	
<input type="checkbox"/> Purchasing (6)	

Is there a colleague within your company that might benefit from having their own copy of **Power Transmission Engineering** magazine?

Name: \_\_\_\_\_  
Title: \_\_\_\_\_

**4** How is THIS LOCATION involved with power transmission products? (Check all that apply)

WE MAKE power transmission products (10)  
 WE BUY power transmission products (12)  
 WE SELL power transmission products (Distributors, sales reps. etc.) (14)  
 WE DESIGN products with power transmission components in them. (16)  
 Other (please describe) (15) \_\_\_\_\_

**DIGITAL SUBSCRIPTIONS**

**YES, I want to be notified each issue when *Power Transmission Engineering* is available online**

**YES, I would like to receive *Power Transmission Engineering's* monthly e-mail newsletter**

**YES, I would like to receive *Power Transmission Engineering's* twice monthly e-mail Product Alerts**

**YES, I would like to receive 3rd-party e-mails from *Power Transmission Engineering's* advertisers and partners**

**YES, I would like to receive subscription renewal notices by e-mail**

**No, I do not wish to be contacted by e-mail.**

**FAX TO 1-847-437-6618** or  
VISIT US ONLINE AT  
[www.powertransmission.com/subscribe.htm](http://www.powertransmission.com/subscribe.htm)

# Now *That's* Smart Manufacturing!

Matthew Jaster, Senior Editor

It takes a self-proclaimed expert an hour or so to solve the puzzle in under 25 moves. A speedcuber (a hobbyist that enjoys figuring out twisty puzzles) figured it out in 4.9 seconds. For the rest of us, many gave up on the colorful, cubic conundrum and moved on to the next '80s fad.

We're talking, of course, about Erno Rubik's puzzle launched internationally in 1980. The Rubik's Cube has been involved in art installations, pop videos, Hollywood films and it even had its own Saturday morning cartoon (*Rubik, the Amazing Cube*).

It made headlines once again in November 2016 at the Electronica Trade Fair in Munich, Germany when a machine called "Sub1 Reloaded" solved the Rubik's Cube in just 637 thousandths of a second—without doubt, the fastest time ever recorded. This was accomplished with the assistance of an AURIX microcontroller from Infineon Technologies—similar to the one used in automotive driver assistance systems.

"Obviously, the AURIX microcontroller was not designed for breaking the Rubik's Cube World Record with a machine," said Fabian Schiffer, media relations manager at Infineon Technologies AG. "But instead the set up was chosen to demonstrate the power and accuracy of the microcontroller in controlling electric motors — of which a lot can be found, for example, in automotive applications."

How was this accomplished exactly? According to Schiffer, the "Sub1 Reloaded" contains a number of other microchips. Like most devices we use every day, they link the real and digital worlds. The attempt started with the press of a button. The shutters of the sensor cameras were removed. The machine then detected the position of the elements. These had been previously scrambled, in accordance with the special requirements of the World Cube Association.

The computing chip, or the "brain" of the machine, figured out the fastest solution and transmitted the necessary commands to the power semiconductors. These "muscles" then activated six motors, one for each side of the cube, at record speed and then brought them to a halt—all within the fraction of a second (ridiculous to imagine and even more ridiculous to watch the video here: [www.youtube.com/watch?v=N1b6iPYj3YQ](http://www.youtube.com/watch?v=N1b6iPYj3YQ).)

Every Rubik's cube can be unscrambled with just 20 moves. A variety of algorithms can be used to solve the puzzle, the most well-known of which is the Fridrich Method. But Infineon's constructor Albert Beer did not design his

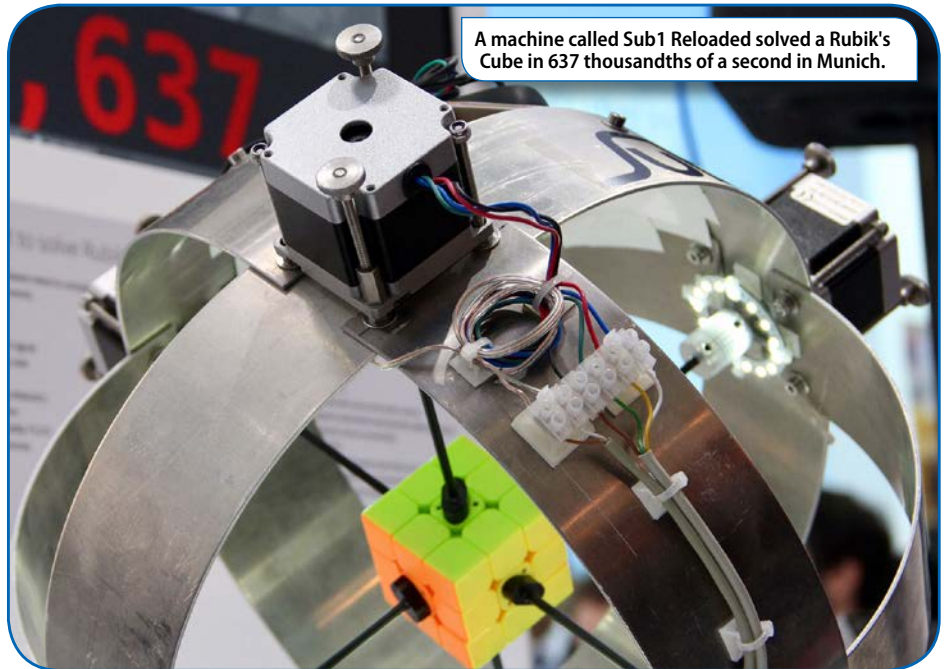

prodigy with the fewest moves in mind. Rather, he was intent on achieving the best time—he even allowed the "Sub1 Reloaded" a few extra moves to reach this goal.

"To be honest, if it was for the AURIX alone, Rubik's Cube could have been solved even faster," Schiffer added. "The machine is limited, plainly speaking, by mechanics. The multicore architecture of the microcontroller is based on up to three independent 32-bit TriCore CPUs; it has been designed to meet the highest safety standards while increasing the performance at the same time."

In addition to solving the Rubik's Cube, Infineon takes pride in supplying Tesla with more than 250 semiconductors for each Model X. The company's devices are built into the electric drivetrain, on-board charger, LED lights and motors for doors, windows, wipers and access control. They also integrated a variable-speed drive compressor in a high-end Liebherr refrigerator to make it more energy efficient.

But the real story at the trade fair was how quickly the Rubik's Cube World Record was broken.

Within a short amount of time, the video received almost 600,000 visits on YouTube. Schiffer said that the video triggered a whirlwind across social media outlets, German television stations and was even featured on the Japanese morning show *Tokudane!*

"Looking back we can state that this was the single most successful event in the history of Infineon involving magazines and newspapers, not taking into account the media coverage during IPO," Schiffer added.

The project and its rapid results, begs a far simpler question to the rest of engineering and manufacturing community:

What can *you* accomplish in 637 milliseconds? **PTE**

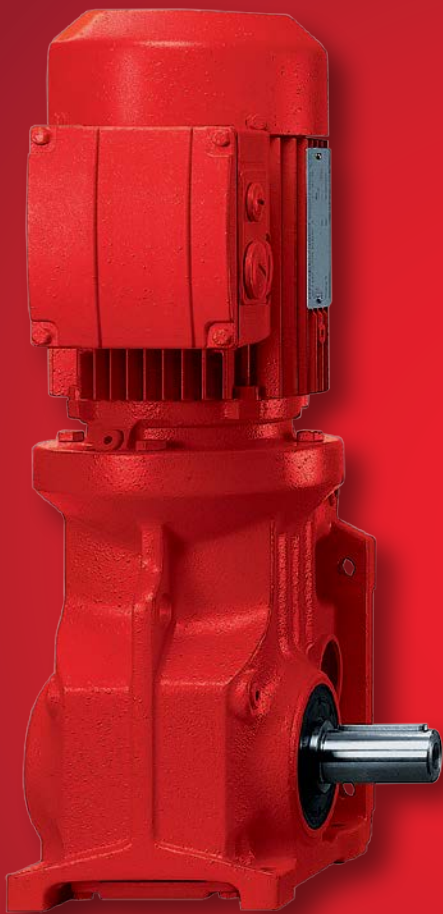
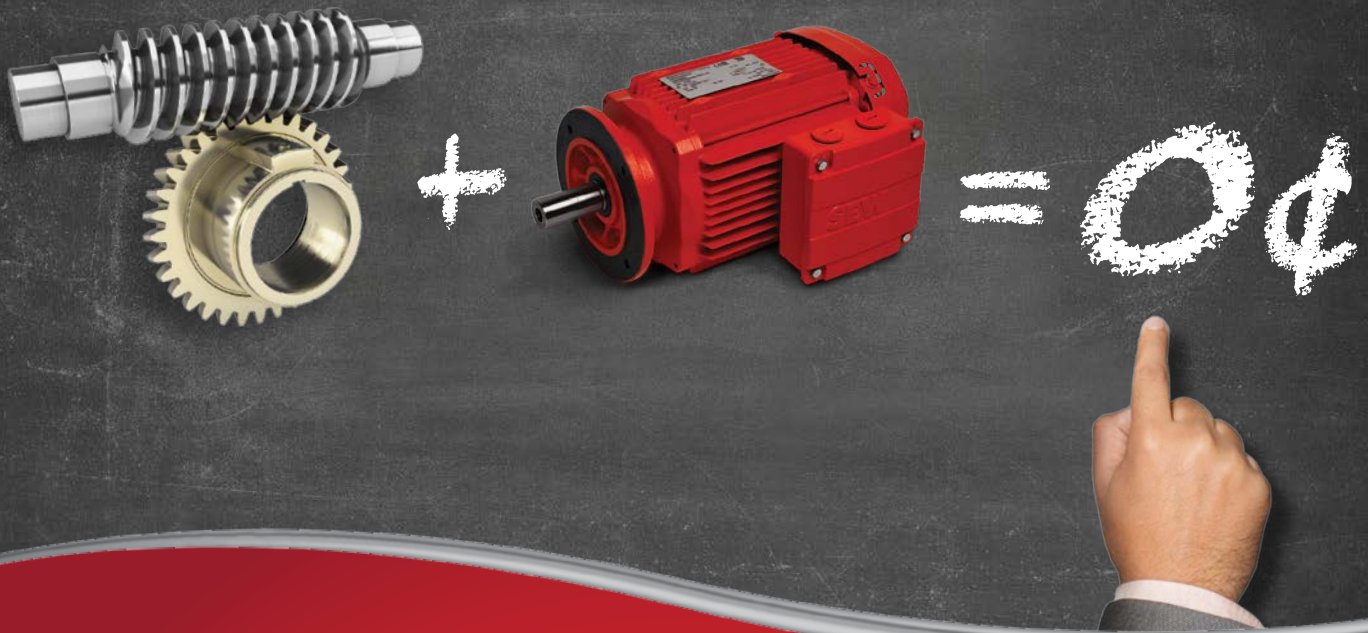

## Makes no cents!

Adding an inefficient worm gearbox to a premium efficient motor doesn't make sense if you are trying to save money.

Why gain 2-3% energy savings with a more efficient motor and then lose 50% or more through the worm gear?

**Solution:** Use a helical-bevel gearmotor from SEW-EURODRIVE and obtain 96% efficiency. Now that makes a lot of cents!

**SEW**  
**EURODRIVE**



**X-life**  
proven to be better



BOOTH NO.  
**S-83348**

# Before You apply hydraulics to

Lift it or Steer it  
Extend it or Retract it  
Actuate it or Cool it  
Press it or Pump it...

**Make sure you X-life™ it!**

Thanks to superfinished raceway surfaces that ensure smooth, uniform running characteristics, maximum load capacity and superior rigidity, the operating life of Schaeffler's X-life bearings is considerably longer than standard bearings under identical operating conditions. Alternatively, higher loads can be applied while maintaining the same rating life values.



Need more details?  
Contact a Schaeffler design engineer  
at 803-548-8552 or [info.us@schaeffler.com](mailto:info.us@schaeffler.com)

[www.schaeffler.us](http://www.schaeffler.us)

©2016

**SCHAEFFLER**