

# Power Transmission Engineering®

## ENGINEERING SHOWCASE



Power Transmission Engineering is POWERED by The American Gear Manufacturers Association



2024  
JAN - DEC



SOCIAL

ONLINE



E-MAIL

PRINT



[powertransmission.com](http://powertransmission.com)

# Power Transmission Engineering®

## 2024 ENGINEERING SHOWCASE

**AGMA Media**  
1001 N Fairfax Street,  
5th Floor,  
Elk Grove Village, IL 60007  
Phone: (847) 437-6604  
Fax: (847) 437-6618  
[friedman@agma.org](mailto:friedman@agma.org)  
[powertransmission.com](http://powertransmission.com)

You have a great story to tell and  
**THIS IS THE PLACE TO TELL IT!**

This special advertorial section will appear in each issue immediately following one of our editorial sections focused on a topic related to what you sell. This provides the perfect opportunity to add to our editorial content with a profile of just what your company can do for our readers in your own words!

Featuring full- or half-page company profiles, this section is designed to educate and inform *PTE* readers and recognize your achievements. This special print promotion (also featured in our online edition) will recognize you as a leading industry supplier and feature your contributions to the advancement of power transmission, fluid power, motion control and mechatronic solutions for those most interested in purchasing from you.

A custom Engineering Showcase advertorial can run as a stand-alone promotion at a special low rate or supplement your traditional advertisement in the same issue at an even lower rate. If you would like help writing your profile article, just ask us for assistance, and we will have an editor contact you.

### 2024 ENGINEERING SHOWCASE TOPICS:

- **Energy**—February issue (closes January 4)
- **Off-Highway**—March issue (closes February 1)
- **Robotics**—April issue (closes February 29)
- **Automotive**—June issue (closes May 2)
- **Heavy Industry**—August issue (closes July 3)
- **Aerospace**—September issue (closes August 1)
- **Packaging/Material Handlin**—October issue (closes September 5)
- **Food & Beverage**—December issue (closes October 31)

As North America's only integrated media brand dedicated to power transmission and motion control, we are focused on cost-effectively delivering your message to the buyers of the products and services you sell.

For more information contact:

**Dave Friedman**  
[friedman@agma.org](mailto:friedman@agma.org)  
**(847) 437-6604**

AGMA Media 1001 N. Fairfax Street, 5th Floor, Alexandria, VA 22314 Phone: 847-437-6604 Fax: 847-437-6618  
[powertransmission.com](http://powertransmission.com)

**Dave Friedman** Associate Publisher & Advertising Sales Manager [friedman@agma.org](mailto:friedman@agma.org)

For complete, detailed information, including ad rates and specs, visit [powertransmission.com/adinfo](http://powertransmission.com/adinfo)



# Schaeffler Engineering

## Greater Than the Sum of Our Parts

When it comes to bearings, Schaeffler, together with our INA and FAG brands, has always been at the forefront of technological innovation. Industry firsts - such as the development of the needle roller & cage assembly, or the groundbreaking ball grinding machine that is regarded as the foundation of the entire rolling bearing industry - have earned Schaeffler a unique distinction among the world's great bearing companies. With nearly 85,000 employees working in approximately 170 locations in 50 countries, Schaeffler is one of the world's largest technology companies in family ownership.

In addition to rolling bearings for practically any application, linear bearings and guidance systems are also a vital part of Schaeffler's product portfolio. Unrivaled in scope and versatility, Schaeffler's linear product lineup ranges from shafts with linear ball bearings and monorail guidance systems to sophisticated actuators with drives and control systems, plus special coatings and every conceivable accessory.

But that's only the start. Schaeffler's linear portfolio is based on a modular concept that goes far beyond mere components. We can design a complete system solution tailored to the customer's specific application - from large gantry robots to intricate circuit board inspection systems. In fact, many of our linear guidance systems started out as solutions to customers' needs! Case in point: Schaeffler's ingenious H-Bot XY positioning system.

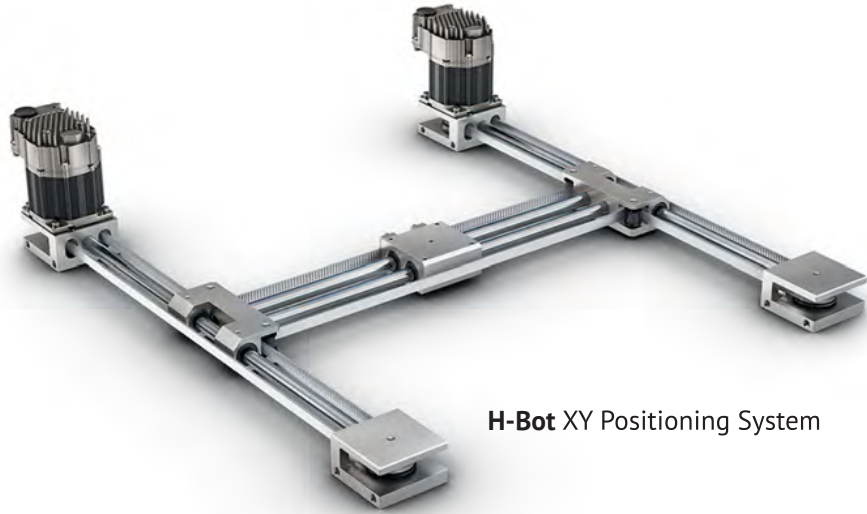

**H-Bot XY Positioning System**

Sometimes, of course, a Schaeffler solution comes about because a customer's needs were not being met by the conventional standard. Such is the case with Schaeffler's innovative PWG differential roller screw. Within the pantheon of mechanical/linear drive systems, the screw category has been limited to lead screws, ball screws and roller screws.

Until now, that is.

In response to a customer's request for a solution that better addressed its ambitious price-performance target, Schaeffler recently developed the PWG differential roller screw: a new option that offers the high forces of a traditional roller screw, but at a price point closer to a ball screw.

So while innovative products make up the heart of Schaeffler's offerings to our customers, service represents the soul of what we do. Because when it comes to linear guidance systems, Schaeffler has all the pieces; you only have to supply the puzzle. Together, we'll create the perfect linear solution... yours.



**PWG Differential Roller Screw**

# SCHAEFFLER

**FOR MORE INFORMATION**

308 Springhill Farm Rd., Fort Mill, SC 29715

Phone: 803-396-3643

Fax: 803-548-8599

Email: [info.us@schaeffler.com](mailto:info.us@schaeffler.com)

[www.schaeffler.us](http://www.schaeffler.us)

# Zero-Max

## Innovation & Leadership

For over 60 years, Zero-Max, Inc. has created innovative solutions to motion control problems worldwide. With strategic distribution points located throughout the world, Zero-Max can deliver your motion control solution.

The Zero-Max team of application specialists can engineer a solution to meet your motion control requirements. With many years of application experience Zero-Max excels in these areas:

- Experienced Practical Application Advice
- Responsive to customer needs
- Predictable high quality
- Fast Delivery
- Integrity
- High Value
- ISO 9001: 2008 certified
- Configurable 3D CAD downloads

Zero-Max Primary Product lines include: Shaft Couplings and Torque Limiters for Servomotors, Linear Actuators,



Wind Turbines, Printing Presses, Label Printing, Converting Machines, Machine Tools, Test Equipment, Feedback devices, Packaging Machines, Process Equipment, Dynamometers, and other high performance applications.

Variable Speed Mechanical Drives for Agricultural, Printing, Peristaltic Pumps, Food Processing, Pharmaceutical, Packaging, and many other applications.

Overhung Load Adaptors for Timber processing, Brush Clearing, Road Construction, Marine, and other rugged applications that need overhung load protection for hydraulic pumps and motors.

Keyless Locking Bushings for Packaging, Processing, Tooling, Automated Assembly, and applications that would benefit from the unique qualities of these bushings.

**ZERO-MAX**

**FOR MORE INFORMATION**

13200 Sixth Avenue North, Plymouth, MN 55441-5509

Phone: 763-546-4300

[www.zero-max.com](http://www.zero-max.com)

# KTR Corporation

## Couplings to Meet the Most Exacting Demands

**KTR Corporation** is a wholly owned and operated subsidiary of KTR Systems GmbH with over 40 subsidiary companies in 26 countries. Our extensive product line began over 50 years ago with the BoWex® curved tooth gear coupling and the ROTEX® torsionally flexible jaw coupling.

Our technological strength and innovative problem-solving concepts have earned us several prestigious design awards. KTR utilizes 3D CAD systems, finite

element analysis and our ability to simulate actual field conditions within our own R&D facility. These tools are employed during the design of new products producing custom solutions geared to our customers' individual specifications.

Manufacturing is performed on state-of-the-art CNC machinery to ensure the highest grade components. We manufacture to AGMA and DIN standards to meet the exacting demands of a global marketplace. Our quality control system is overseen by a dedicated staff that takes pride in providing customers with excellent service, consistent products and exceptional value.

KTR Corporation is recognized as a highly competent power transmission partner. Our objective is to manufacture products of the highest quality, provide superior service, product

Made for Motion



**FOR MORE INFORMATION**

122 Anchor Rd, Michigan City, IN 46360

Phone: (219) 872-9100

Fax: (219) 872-9150

E-mail: [ktr-us@ktr.com](mailto:ktr-us@ktr.com)

[www.ktr.com](http://www.ktr.com)



# Power Transmission Engineering®

**AGMA Media**  
1001 N Fairfax Street,  
5th Floor,  
Elk Grove Village, IL 60007  
Phone: (847) 437-6604  
Fax: (847) 437-6618  
[friedman@agma.org](mailto:friedman@agma.org)  
[powertransmission.com](http://powertransmission.com)

## 2024 ENGINEERING SHOWCASE AD ORDER

Sold To: \_\_\_\_\_ Date: \_\_\_\_\_

Name: \_\_\_\_\_

Company: \_\_\_\_\_

Billing Address: \_\_\_\_\_

City, State: \_\_\_\_\_ Zip / Postal Code: \_\_\_\_\_

Country: \_\_\_\_\_ Phone Number: \_\_\_\_\_

E-mail: \_\_\_\_\_

Please publish our Engineering Showcase article in the following issue(s) of *Power Transmission Engineering*:

**Full Page**  
\$2,195

**Half Page**  
\$1,195

_____	_____	<b>Energy</b> —February issue (closes January 4)
_____	_____	<b>Off-Highway</b> —March issue (closes February 1)
_____	_____	<b>Robotics</b> —April issue (closes February 29)
_____	_____	<b>Automotive</b> —June issue (closes May 2)
_____	_____	<b>Heavy Industry</b> —August issue (closes July 3)
_____	_____	<b>Aerospace</b> —September issue (closes August 1)
_____	_____	<b>Packaging/Material Handling</b> —October issue (closes September 5)
_____	_____	<b>Food &amp; Beverage</b> —December issue (closes October 31)

**Advertiser (Agency / Obligor) Please sign here:**

**Signature:** \_\_\_\_\_ **Date:** \_\_\_\_\_

This agreement is binding after final acceptance by AGMA Media and subject to the terms and conditions as noted at [powertransmission.com/terms.pdf](http://powertransmission.com/terms.pdf).